

100 Series Riding Lawn Tractors North American Serial Number 500001-



JOHN DEERE

OPERATOR'S MANUAL

S100, S110, S120, S130, S140, S160,
S170, and S180 Tractors

OMUC44974 ISSUE K5 (ENGLISH)

CALIFORNIA

Proposition 65 Warning

Diesel engine exhaust and some of its constituents are known to the State of California to cause cancer, birth defects, and other reproductive harm.

If this product contains a gasoline engine:

WARNING

The engine exhaust from this product contains chemicals known to the State of California to cause cancer, birth defects or other reproductive harm.

The State of California requires the above two warnings.

John Deere Power Products

North American Edition
PRINTED IN U.S.A.



* D C Y *



* O M U C 4 4 9 7 4 *

Introduction

Thank You for Purchasing a John Deere Product

We appreciate having you as a customer and wish you many years of safe and satisfied use of your machine.

MX00654,000020B-19-17SEP25

Required Emission-Related Information

Service Provider

A repair shop or person of the owner's choosing may maintain, replace, or repair emission control devices and systems with original or equivalent replacement parts. However, warranty, recall, and all other services paid for by John Deere must be performed at an authorized John Deere service center.

DX,EMISSIONS,REQINFO-19-08DEC23

Emissions Performance and Tampering

Operation and Maintenance

The engine, including the emissions control system, shall be operated, used, and maintained in accordance with the instructions provided in this manual to maintain the emissions performance of the engine within the requirements applicable to the engine's category/certification.

Tampering

No deliberate tampering with or misuse of the engine emissions control system shall take place; in particular with regard to deactivating or not maintaining an exhaust gas recirculation (EGR) or a DEF dosing system. Tampering with an engine's emissions control system will void the European Union (EU) type approval and applicable emissions-related warranties.

DX,EMISSIONS,PERFORM-19-12JAN18

Using Your Operator's Manual

Read this operator's manual, watch the safety video, www.deere.com/QR and review the safety signs on your machine before use. They all contain important safety information and operating instructions that must be followed to help keep you and others safe. Be sure everyone who uses the machine has read the manual, reviewed the safety signs, and knows how to use the machine safely and properly.

Your machine was designed and built to be operated in accordance with all the safe operating instructions. Since it was designed to cut grass, it can amputate hands and feet and throw objects. If you do not follow safety instructions, serious injury or death can occur.

This operator manual is organized in sections to help you find information quickly. You can use this manual to find answers to many of your operating and servicing questions. An index at the end of this book helps you

find needed information quickly. Contact your dealer if this manual does not answer your questions.

Before using your machine:

- Know how to operate the machine. The Operating Controls section helps you understand the controls of your machine and what they do.
- Prepare your machine and the mowing area by performing required daily checks outlined in the General Instructions section.
- Follow instructions in the Preventing Injuries section, especially related to:
 - Keeping children safe by following instructions in the Protect Children section.
 - Avoiding injury on slopes and near terrain hazards by following instructions in the Operating on Slopes and Near Terrain Hazards section.
 - Follow the instructions in the Avoid Thrown Objects section and keep all guards in place, including discharge chute.
 - Cleaning machine during use and before storing as outlined in the Prevent Fires section.
- Understand how to service and inspect your machine.

If you do not understand the instructions or have questions, contact your dealer.

The machine shown in this manual can differ slightly from your machine.

RIGHT-HAND and LEFT-HAND sides are determined by facing in the direction that the machine travels when going forward. When you see a broken line (-----), the item referenced is hidden from view.

Before delivering this machine, your dealer performed a predelivery inspection to ensure best performance.

This manual is an important part of your machine. Keep this manual with the machine when you sell it.

mk71445,1654877011782-19-10JUN25

John Deere Is at Your Service

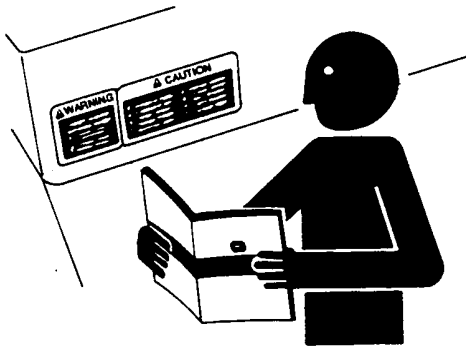

TS201—UN—15APR13

Customer satisfaction is important to John Deere.

Our dealers strive to provide you with prompt, efficient parts, and service:

- Maintenance and service parts to support your equipment.
- Trained service technicians and the necessary diagnostic and repair tools to service your equipment.
- **John Deere replacement parts, repair services, and information for maintenance or repair are available. For more information, please visit deere.com or deere.ca.**

DX,IFC,,JDS-19-30SEP25

Special Messages

Your manual contains special messages to bring attention to potential safety concerns and machine damage, as well as helpful operating and servicing information. Please read all the information carefully to avoid injury and machine damage.

⚠ CAUTION: Avoid injury! This symbol and text highlight potential hazards or death to the operator or bystanders that may occur if the hazards or procedures are ignored.

IMPORTANT: Avoid damage! This text is used to tell the operator of actions or conditions that might result in damage to the machine.

NOTE: General information is given throughout the manual that may help the operator in the operation or service of the machine.

MX00654,000020D-19-04AUG25

Parts

We recommend John Deere quality parts and lubricants, available at your John Deere dealer.

When you order parts, your John Deere dealer needs the serial number or product identification number (PIN) for your machine or attachment. These are the numbers that you recorded in the Product Identification section of this manual.

Order Service Parts Online

Visit <https://partscatalog.deere.com/jdrc/> for your Internet connection to parts ordering and information.

TC00531,00000E9-19-04AUG25

Service Literature

If you would like to purchase a copy of the Parts Catalog or Technical Manual for this machine, visit The John Deere Technical Information Store at:

<https://techpubs.deere.com/>

or call:

- **U.S. & Canada:** 1-800-522-7448.
- **All Other Regions:** Your John Deere dealer.

TH84124,0000199-19-04AUG25

Spark Arrestor

The California Public Resources Code, Section 4442.5 provides as follows:

No person shall sell, offer for sale, lease, or rent to any person any internal combustion engine subject to Section 4442 or 4443, and not subject to Section 13005 of the Health and Safety Code, unless the person provides a written notice to the purchaser or bailee, at the time of sale or at the time of entering into the lease or rental contract, stating that it is a violation of Section 4442 or 4443 to use or operate the engine on any forest-covered, brush-covered, or grass-covered land unless the engine is equipped with a spark arrestor, as defined in Section 4442, maintained in effective working order or the engine is constructed, equipped, and maintained for the prevention of fire pursuant to Section 4443. Cal. Pub. Res. Code 4442.5. Other states or jurisdictions may have similar laws. A spark arrestor for your machine may be available from your John Deere dealer or other servicing provider. An installed spark arrestor must be maintained in good working order by the operator.

OUO2005,00006F6-19-17OCT25

Trademarks

Trademarks	
CargO Mount™	Trademark of Deere & Company
Deere	Trademark of Deere & Company
Plus-50	Trademark of Deere & Company
John Deere	Trademark of Deere & Company
Turf-Gard	Trademark of Deere & Company
John Deere Easy Change™	Trademark of Deere & Company
MowerPlus™	Trademark of Deere & Company
Plus-4™	Trademark of Deere & Company
Grease-Gard™	Trademark of Deere & Company

Contents

	Page		Page
Product Identification		Testing Safety Systems	30-4
Record Identification Numbers	00-1	Testing Park Brake Switch	30-5
Register Your Product and Warranty Online	00-1	Testing Park Brake	30-5
Safety Labels with Text		Testing Attachment Engagement Switch or Lever	30-5
Safety Label Location	05-1	Testing Seat Switch	30-5
Understanding the Machine Safety Labels	05-2	Testing Reverse Implement Option (RIO)	30-5
DANGER	05-2	Using the Park Brake	30-6
DANGER	05-2	Checking Fuel Level (If Equipped)	30-6
DANGER	05-2	Using Hourmeter and MowerPlus™ Fuel Gauge (If Equipped)	30-6
WARNING	05-3	Using Key Switch and Headlights	30-7
CAUTION	05-3	Starting the Engine	30-7
Avoid Injury From Hot Surface	05-3	Idling the Engine	30-7
CAUTION	05-4	Stopping the Engine	30-8
Safety Labels without Text		Using Travel Controls on Hydrostatic Transmission	30-8
Safety Label Location	06-1	Using The Reverse Implement Option (RIO)	30-9
Understanding the Machine Safety Labels without Text	06-2	Using Cruise Control (If Equipped)	30-9
Read Operator's Manual	06-2	Engaging and Disengaging Mower	30-9
Keep Children Away from Mower	06-2	Using Wash Port to Clean Mower Deck	30-10
Avoid Serious Injury or Death from Tipping	06-2	Unplugging Mower, Bagger, or Material Collection System	30-10
Avoid Injury from Getting Caught in Belts	06-2	Moving Machine by Hand	30-10
Avoid Injury from Equipment Fires	06-3	Transporting Machine on Trailer	30-11
Avoid Injury from Rotating Blades	06-3	Transporting Material Collection System (If Equipped)	30-12
Avoid Injury from Hot Surfaces	06-3	Using Weights	30-12
Avoid Injury from Rotating Blades and Thrown Objects	06-3	Using Tire Chains	30-12
Safety		Using Accessories	30-12
Use Your Mower Safely	10-1	Choosing Mower Blades	30-13
Preventing Injuries	10-2	Mowing Tips	30-13
Operating on Slopes and Near Terrain Hazards	10-2	Towing Loads	30-13
Prevent Fires	10-3	Service Intervals	
Parking Safely	10-4	Servicing Your Machine	35-1
Additional Safety Information	10-4	Service Intervals	35-1
Machine Cleanout		Service Lubrication	
General Cleaning Guidelines	15-1	Grease	40-1
Cleanout Areas	15-1	Lubricating Front Axle	40-1
Operating Controls		Lubricating Pivot Points	40-1
Operator's Station Controls	25-1	Service Engine	
Operating		Emissions Service Information	45-1
Daily Operating Checklist	30-1	Avoid Fumes	45-1
Adjusting Seat	30-1	Gasoline Engine Oil	45-1
Adjusting Cutting Height	30-1	Checking Engine Oil Level	45-2
Checking and Adjusting Mower Deck Level	30-1	Changing John Deere Easy Change™ 30- Second Oil Change System (If Equipped)	45-2
Adjusting Mower Deck Wheels	30-4		

Continued on next page

Original Instructions. All information, illustrations and specifications in this manual are based on the latest information available at the time of publication. The right is reserved to make changes at any time without notice.

Contents

	Page		Page
Changing Engine Oil and Filter on models not equipped with the John Deere Easy Change™ 30-Second Oil Change System	45-3	Preparing Fuel and Engine For Storage	75-1
Cleaning Air Intake Screen and Engine Fins	45-4	Removing Machine From Storage	75-2
Checking and Cleaning Air Cleaner Elements	45-4		
Checking Spark Plug	45-6	Specifications	
Replacing Fuel Filter	45-6	Model S100	80-1
Spark Arrestor Maintenance (If Equipped)	45-7	Model S110	80-1
		Models S120, S130, S140, and S160	80-1
Service Transmission		Models S170 and S180	80-1
Checking Transmission	50-1	Electrical System	80-1
		Fuel System (All Models)	80-1
Service Mower		Tires	80-1
Removing or Installing Mower Drive Belt at Engine Drive Sheave in Manual PTO Machines	55-1	Capacities	80-2
Removing or Installing Mower Drive Belt at Engine Drive Sheave in Electronic PTO Machines	55-1	Dimensions	80-2
Removing Mower Deck	55-1	Mower Deck - 107 cm (42 in)	80-2
Installing Mower Deck	55-3	Mower Deck - 122 cm (48 in)	80-2
Replacing Mower Drive Belt—42 in Deck	55-3	Mower Deck - 137 cm (54 in)	80-2
Replacing Mower Drive Belt—48 in and 54 in Decks	55-4	Recommended Lubricants	80-2
Checking for Bent Mower Blades	55-4		
Servicing Mower Blades	55-5	Warranty	
Sharpen Blades	55-5	Product Warranty	85-1
Balance Blades	55-6	U.S. EPA Emission Control System Warranty Statement (Off-Road Engine Equipment)	85-1
		Tire Warranty	85-3
Service Electrical		Limited Battery Warranty For Factory Installed Batteries	85-3
Electrical	60-1		
Service the Battery Safely	60-1	John Deere Quality Statement	
Removing and Installing the Battery	60-1	John Deere Quality	JDQS-1
Clean Battery and Terminals	60-2		
Use Booster Battery	60-2	Service Record	
Replacing Headlight	60-2	Record Service Dates	SR-1
Replacing Fuse	60-3		
		Slope Gauge	
Service Miscellaneous		Slope Gauge Template	SG-1
Gasoline Fuel for 4-Cycle Engines	65-1		
Fill Fuel Tank	65-1		
Lifting Machine	65-1		
Checking Tire Pressure	65-2		
Removing and Installing Hood	65-2		
Cleaning Plastic Surfaces	65-3		
Cleaning and Repairing Metal Surfaces	65-3		
Avoid Damage to Plastic and Painted Surfaces	65-3		
Removing and Installing Front Wheel Assembly	65-4		
Removing and Installing Rear Wheel Assembly	65-4		
Troubleshooting			
Using Troubleshoot Chart	70-1		
Engine	70-1		
Electrical	70-1		
Tractor	70-2		
Mower	70-2		
Storage			
Storing Safety	75-1		
Preparing Machine for Storage	75-1		

Product Identification

Record Identification Numbers

Lawn Tractors

S Series Riding Lawn Tractors.

When you contact an Authorized Service Center for information on servicing, always provide the product model and product identification numbers.

Locate the model, product identification number, and engine serial number of your machine. Record the information in the space provided as follows:

DATE OF PURCHASE:

DEALER NAME:

DEALER PHONE:

PRODUCT IDENTIFICATION NUMBER:

ENGINE SERIAL NUMBER:

Machine Product Identification Number Location



APY33773—UN—06APR20

Left-Hand Side of the Machine Shown

Engine Serial Number Location

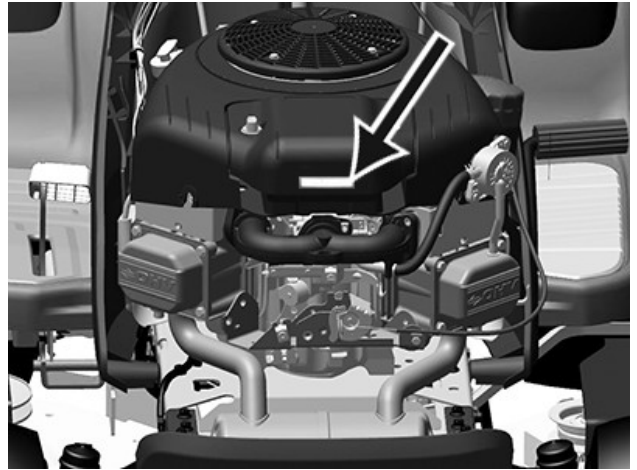

APY33771—UN—06APR20

V-Twin Cylinder Engine Model Shown

SDHTXN6,1745648864442-19-26APR25

Register Your Product and Warranty Online

To register your product through the Internet, simply go to www.JohnDeereWarrantyRegistration.com.

Completing the information, either online or with the product warranty card, will ensure that your product will receive all post sales, service, and important product information.

MP47322,00F45FF-19-17MAY22

Safety Labels with Text

Safety Label Location



⚠ DANGER	⚠ WARNING	⚠ CAUTION
ROTATING BLADES CUT OFF ARMS AND LEGS <ul style="list-style-type: none"> • Do not mow when children or others are around • Do not mow in reverse • Look down and behind before and while backing • Look in the direction the machine is traveling • Never carry children even while blades are off 	AVOID SERIOUS INJURY OR DEATH FROM ROLLOVER <ul style="list-style-type: none"> • Do not drive where the machine could slip or tip, on steep slopes, near water, or drop-offs • Drive up and down slopes, not across • If machine loses traction on a slope, stop blade, and proceed slowly off slope • Avoid sudden starts, turns, and stops 	<ul style="list-style-type: none"> • Read operator's manual and watch safety video • Keep safety devices (guards, shields, and switches) in place and working • Pick up objects that can be thrown by blades • When leaving machine: <ul style="list-style-type: none"> - Stop engine - Set park brake - Remove key

⚠ CAUTION

- Read operator's manual and watch safety video
- Keep safety devices (guards, shields, and switches) in place and working
- Pick up objects that can be thrown by blades
- When leaving machine:
 - Stop engine
 - Set park brake
 - Remove key

⚠ DANGER

ROTATING BLADE

Do not put hands or feet under or into mower when engine is running

⚠ WARNING

Hot surface

⚠ DANGER

ROTATING BLADE

DO NOT PUT HANDS OR FEET UNDER OR INTO MOWER WHEN ENGINE IS RUNNING

THROWN OBJECTS

BEFORE MOWING, CLEAR AREA OF OBJECTS THAT MAY BE THROWN BY BLADE

DO NOT OPERATE MOWER WITHOUT DISCHARGE CHUTE OR ENTIRE GRASS CATCHER IN PLACE

⚠ DANGER

To avoid injury from rotating blades and thrown objects:

Keep hands and feet away from rotating blades. Keep bystanders a safe distance away. Do not operate mower without discharge chute or entire grass catcher in place.

A—WARNING— GX23479
 B—DANGER/WARNING/CAUTION — UC43017
 C—CAUTION— UC27081

D—DANGER — M139128
 E—DANGER — M89504
 F—DANGER — M118610

MX663345—UN—06MAY25

SDHTXN6,1745831068322-19-06MAY25



Understanding the Machine Safety Labels

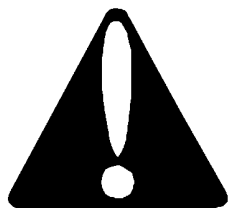

MXAL42363—UN—22MAY13

The machine safety labels shown in this section are placed in important areas on your machine to draw attention to potential safety hazards. DANGER or WARNING safety labels are located near specific hazards.

The operator's manual also explains any potential safety hazards whenever necessary in special safety messages that are identified with the word, CAUTION, and the safety-alert symbol.

On your machine safety labels, the words DANGER, WARNING, and CAUTION are used with this safety-alert symbol. DANGER identifies the most serious hazards:

- **DANGER;** The signal word DANGER indicates a hazardous situation which, if not avoided, will result in death or serious injury.
- **WARNING;** The signal word WARNING indicates a hazardous situation which, if not avoided, could result in death or serious injury.
- **CAUTION;** The signal word CAUTION indicates a hazardous situation which, if not avoided, could result in minor or moderate injury. CAUTION may also be used to alert against unsafe practices associated with events which could lead to personal injury.

Replace missing or damaged safety labels. Use this operator's manual for correct safety label placement.

There can be more safety information contained on parts and components sourced from suppliers that is not reproduced in this operator's manual.

French or Spanish Safety Labels and Operator's Manual

Operator's manuals and safety labels with content in French or Spanish are available for this machine through authorized John Deere dealers. See your John Deere dealer.

NOTE: Both text and no-text labels are shown. Your machine is only equipped with one of these types of labels.

MP47322,00F4601-19-21FEB23

DANGER

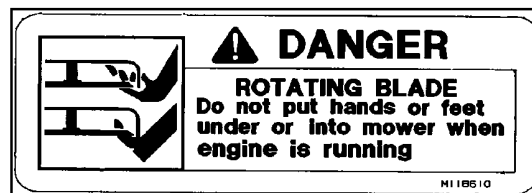

GXAL41947—UN—04MAR13

ROTATING BLADE

- Do not put hands or feet under or into mower when engine is running.

OOU2004,0000BAF-19-28FEB15

DANGER

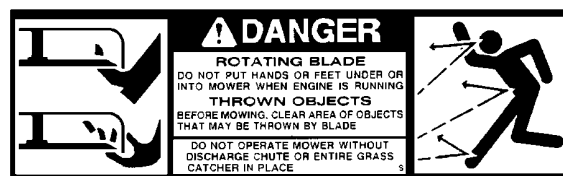

GXAL41948—UN—04MAR13

ROTATING BLADE

- Do not put hands or feet under or into mower when engine is running.

THROWN OBJECTS

- Before mowing, clear area of objects that may be thrown by blade.
- Do not operate mower without discharge chute or entire grass catcher in place.

OOU2004,0000BB0-19-28FEB15

DANGER

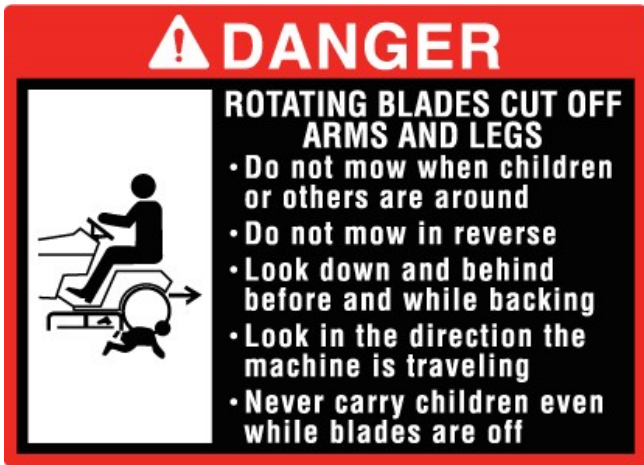

MX663346—UN—06MAY25

ROTATING BLADES CUT OFF ARMS AND LEGS

- Do not mow when children or others are around.
- Do not mow in reverse.
- Look down and behind before and while backing.
- Never carry children, even with the blades off.

SDHTXN6,1745831127013-19-06MAY25

CAUTION



MX663348—UN—06MAY25

- Read the operator's manual and watch the safety video.
- Keep safety devices (guards, shields, and switches) in place and working.
- Pick up objects that can be thrown by blades.
- When leaving the machine:
 - Stop the engine
 - Set the park brake
 - Remove the key

SDHTXN6,1745831157966-19-06MAY25

WARNING



MX663347—UN—06MAY25

AVOID SERIOUS INJURY OR DEATH FROM ROLLOVER

- Do not drive where the machine could slip or tip, such as on steep slopes, near water, or drop-offs.
- Drive up and down slopes, not across them.
- If the machine loses traction on a slope, stop the blade, and proceed slowly off the slope.
- Avoid sudden starts, turns, and stops.
- Never mow or operate the machine on slope angles greater than 13 degrees.

SDHTXN6,1745831186522-19-01JUN25

Avoid Injury From Hot Surface

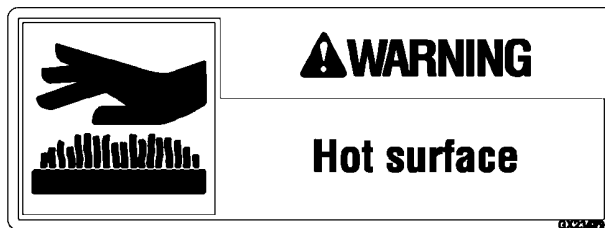

GXAL41952—UN—04MAR13

WARNING

- Hot surface

OOU2004,0000BB3-19-28FEB15

CAUTION



APY36145—UN—10JUL20

Avoid equipment fires

Accumulation of grass, leaves and other debris on or near hot or moving parts can cause a fire

Inspect machine before, during, and after use

Shut off engine and allow machine to cool before cleaning

MG39705.00004A7-19-26JUN20

Safety Labels without Text

Safety Label Location

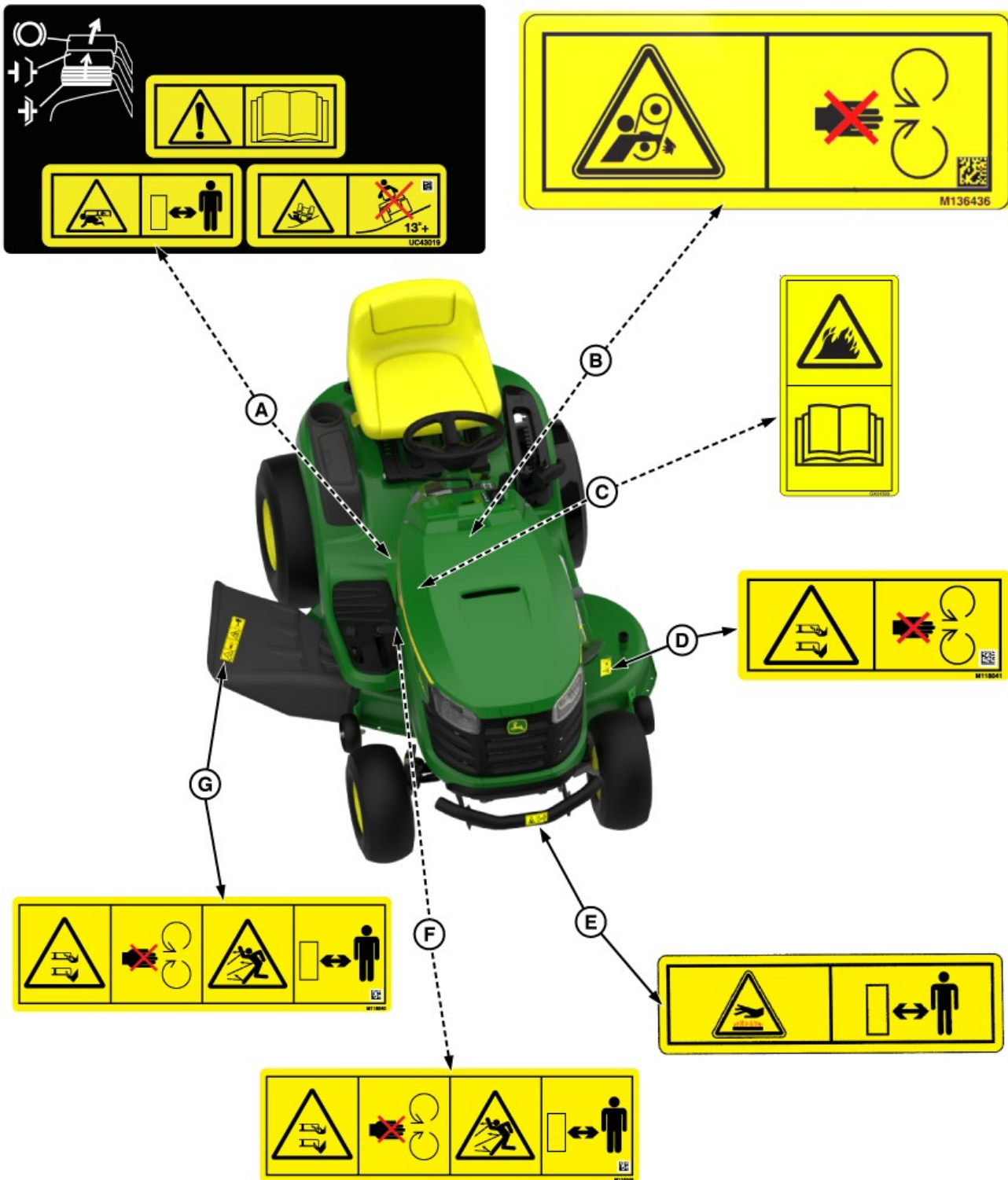

MX663349—UN—06MAY25

A—Read OM, Keep Children Away from Mower; Avoid Injury from Tipping — UC43019

B— Avoid Injury from Getting Caught in Belt — M136436

C— Avoid Injury from Equipment Fires — GX24503

D— Avoid Injury from Rotating Blades — M118041

E— Avoid Injury from Hot Surfaces — GX25568

F— Avoid Injury from Rotating Blades and Thrown Objects — M148522

**G— Avoid Injury from Rotating Blades and Thrown Objects —
M118040**

SDHTXN6,1745840712744-19-06MAY25

Understanding the Machine Safety Labels without Text



TCT005498—UN—11SEP12

The machine safety labels shown in this section are placed in important areas on your machine to draw attention to potential safety hazards.

On your machine safety labels, the words DANGER, WARNING, and CAUTION are used with this safety-alert symbol. DANGER identifies the most serious hazards.

MX00654,0000389-19-09JAN23

- Make sure that children stay clear of mower at all times when the engine is running.

MX00654,000038D-19-08APR24

Avoid Serious Injury or Death from Tipping



GX669619—UN—02JUN25

- Do not drive where the machine could slip, tip, or roll over.
- Never mow or operate the machine on slope angles greater than 13 degrees.
- Refer to the "Operating on Slopes" section for more information.

SDHTXN6,1745840798584-19-10JUN25

Read Operator's Manual

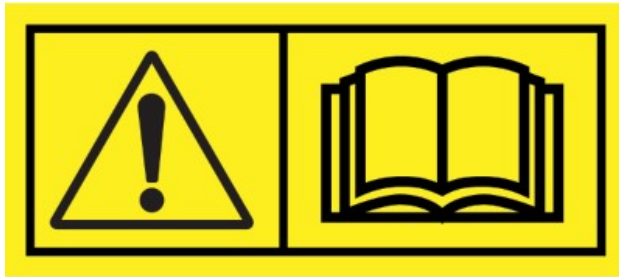

MX682199—UN—31JUL25

- This operator's manual contains important information necessary for safe machine operation.
- Carefully read operator's manual before operating machine or attachment. Observe all safety rules to avoid accidents.

MX00654,000038B-19-04AUG25

Avoid Injury from Getting Caught in Belts

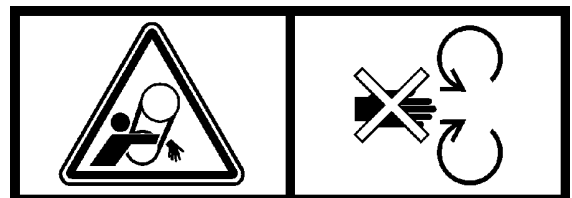

MXT018017—UN—03MAY16

- Stay clear of moving belts.
- Do not operate machine without shields in place.

MX00654,0000391-19-24APR19

Keep Children Away from Mower

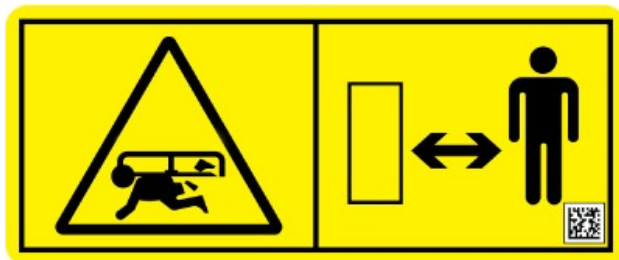

TC1362283—UN—28MAR24

- Mower can cause dismemberment or death.
- Stay a safe distance from the machine.



Avoid Injury from Equipment Fires



APY36195—UN—10JUL20

- Avoid equipment fires.
- Accumulation of grass, leaves, and debris on or near hot or moving parts can cause a fire.
- Inspect and clean the entire machine before, during and after use.
- Shut off engine and allow machine to cool before cleaning.
- Carefully read operator's manual Machine Cleanout section for details.

MG39705,00004B6-19-06JUL20

- Do not operate mower without discharge chute/ deflector or entire grass catcher in place.

MX00654,0000392-19-08APR24

Avoid Injury from Hot Surfaces

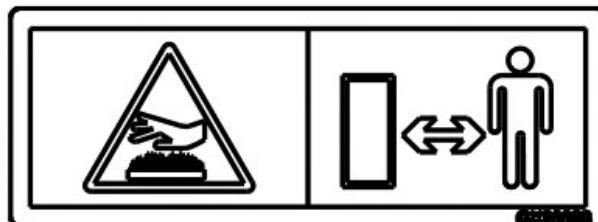

APY36196—UN—10JUL20

- Keep away from hot surfaces.

MG39705,00004B7-19-06JUL20

Avoid Injury from Rotating Blades and Thrown Objects



APY36197—UN—10JUL20

Avoid injury from rotating blade and thrown objects. Do not operate blower without entire grass catcher in place. Shut engine off before unclogging or servicing.

MG39705,00004B8-19-06JUL20

Avoid Injury from Rotating Blades



TC1362285—UN—28MAR24

- Do not put hands or feet under or into mower when engine is running.

Safety

Use Your Mower Safely

General Instructions

- Read this operator's manual, watch the safety video, and review the safety signs on your machine before use. They all contain important safety information and operating instructions that must be followed to help keep you and others safe. Be sure everyone who uses the machine has read the manual, reviewed the safety signs, and knows how to use the machine safely and properly.
- Never mow when there is a risk of lightning.
- Age, physical ability, and mental capacity can be factors in equipment-related injuries. Operators must be mentally and physically capable of operating the machine properly and safely. Never allow a child to operate the machine.
- Do not operate the machine while under the influence of alcohol or drugs or when distracted or fatigued. Proper operation requires your full attention.
- Always wear eye protection, hearing protection, close-fitting clothing, and substantial footwear while operating the machine. Never operate while wearing sandals or when barefoot.
- Do not wear radio or music headphones. Both safe operation and service require your full attention.
- Never tamper with safety devices.
- Operate the machine only in daylight or good artificial light.
- Only operate the engine in well-ventilated areas. Exhaust gasses contain carbon monoxide, a deadly poison.
- Never leave a running machine unattended.
- Look both ways when approaching roadways and use caution when turning around on public roadways. You can be struck by a vehicle and suffer serious injury or death.

Before Using Your Machine

- Know how to operate the machine. The Operating Controls section helps you understand the controls of your machine and what they do.
- Prepare your machine and the mowing area by performing required daily checks outlined in the General Instructions section.
- Follow instructions in the Preventing Injuries section, especially related to:
 - Keeping children safe by following instructions in the Protect Children section.
 - Avoiding injury on slopes and near terrain hazards by following instructions in the Operating on Slopes and Near Terrain Hazards section.
 - Follow the instructions in the Avoid Thrown Objects section, and keep all guards in place, including discharge chute.

- Cleaning machine during use and before storing as outlined in the Prevent Fires section.

- Understand how to service and inspect your machine.

Inspection and Daily Checklist

- Inspect machine before you operate. Be sure that hardware is tight, and all guards and shields are in good condition and fastened in place. Make all necessary adjustments before you operate. Repair or replace damaged, badly worn, or missing parts.
- Visually inspect that mower blades, blade bolts, and the mower assembly are not worn or damaged. To prevent machine damage, replace worn or damaged blades and bolts in sets.
- Make sure that the fuel cap and air cleaner are in place before starting engine.

Fuel

- Use care when handling fuel. Fuel is flammable and fuel vapors can be explosive. Do not smoke when handling fuel. Only use an approved fuel container. Clean up spilled fuel immediately.
- Check fuel lines, tank, cap, and fittings frequently for cracks or leaks. Replace if necessary.

Check the Mowing Area

- Keep bystanders and pets out of the mowing area.
- Clear the area of objects such as rocks, wire, or toys, which can be thrown by the blades. Remove low-hanging branches or other obstacles, which can interfere with your travel path.
- Study the mowing area. Set up a safe mowing path. Do not mow where traction or stability is doubtful.
- Slopes and terrain hazards are major factors related to loss-of-control and tipover accidents. Operation on slopes and near terrain hazards requires extra caution. Follow instructions in the Operating on Slopes and Near Terrain Hazards section.

Weights and Attachments

- Some attachments require ballast weights. Follow recommendations for wheel weights or counterweights.
- Use only accessories and attachments approved by John Deere.
- If you do not understand the instructions or have questions, contact your dealer or other service provider.

SDHTXN6.1745840906380-19-29JUL25

Preventing Injuries

Protect Children

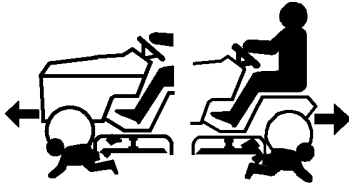

MXAL41929—UN—18FEB13

- Children can be killed or seriously injured by riding mowers when operators do not follow safe operating practices.
- Do not mow in reverse. Operating with the mower engaged while backing up is discouraged.
- Never give children a ride on a mower or in a cart behind the mower, even when the blades are off. They can fall off and be run over or cut by the mower blades. Children can interfere with mower operation. Children who have been given rides in the past can suddenly appear in the mowing area for another ride. If you are not aware, they can be run over or backed over by the mower.
- Children are often attracted to lawn mowers and mowing activities, especially if they have been given rides before. They do not know if the blades are rotating or understand that they can be killed or seriously injured even if the blades are not rotating.
- Keep children indoors and out of the mowing area when the mower is being operated. Keep children under the watchful eye of a responsible adult, other than the operator. If there is not a responsible adult to ensure that children stay indoors, DO NOT mow.
- Be alert to the presence of children or others. Turn off the mower blades and stop the machine if someone enters the mowing area.
- Look in the direction the machine is traveling. Before and while backing, turn off the mower blades and look down and behind the machine carefully, especially for children.
- Use extreme care when approaching objects that block your view, such as blind corners, shrubs, or trees, especially while backing. They can hide a child.

Avoid Thrown Objects

- Clear the mowing area of all bystanders when using this machine. Thrown objects could cause serious injury or death.
- Clear the area of objects such as rocks, wire, or toys, which can be thrown by the blades.
- Never direct discharged material toward anyone.
- Avoid discharging material against a wall or obstruction such as a fence or retaining wall. Material can ricochet towards the operator.

- Avoid discharging material towards a street or roadway.
- Stop the blades when crossing gravel surfaces.

OUO2005.0000783-19-15FEB20

Operating on Slopes and Near Terrain Hazards

- Slopes are a major factor related to loss of control and tip-over accidents, which can result in serious injury or death. Use caution and common sense when operating on slopes.
- If you feel uneasy on a slope, do not mow or operate the machine on it.
- Drive up and down slopes, not across them.
- Watch for holes, ruts, bumps, rocks, or other hidden objects. Tall grass can hide obstacles.
- Drive slowly so you do not have to stop while on a slope.
- Do not mow on wet grass. Tires can slip on wet grass even if the brakes are working normally.
- Keep all movement on slopes slow and gradual. Do not make sudden changes in speed or direction, which can cause the ride-on mower to roll over.
- If the tires lose traction, disengage the PTO and proceed slowly and carefully off the slope.
- Do not shift to neutral and coast downhill.

Identify Safe Slopes

- Before using your machine, measure the slopes of all mowing areas to determine which slopes are safe for mowing with a ride-on mower. Use good judgment and common sense when performing this survey.

Measuring Slopes

- Suggested method 1: Lay a straight piece of sturdy lumber 1.2 m (4 ft) long on the slope and measure the angle with an angle gauge or protractor level.
- Suggested method 2: Refer to the slope gauge provided at the end of the manual.

Slope Limits

- Exceeding the recommended maximum slope angle increases the risk of rollover accidents that can result in serious injury or death.

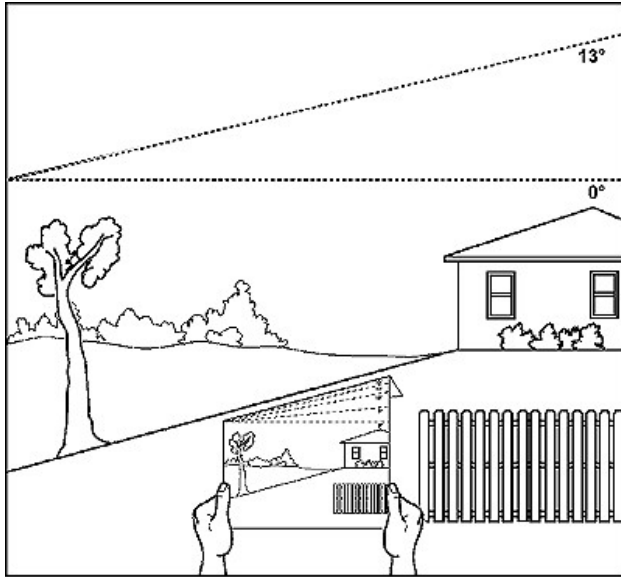

GX100108—UN—14FEB20

- Never mow or operate this ride-on mower on slope angles greater than 13°. (A 13° slope is a slope that rises 1.4 m [4.6 ft] over a horizontal distance of 6.1 m [20 ft].)
- Material collection systems, weather enclosures, or other attachments increase the risk of a rollover.
- As slope increases the risk of rollover increases.

Operating Near Terrain Hazards

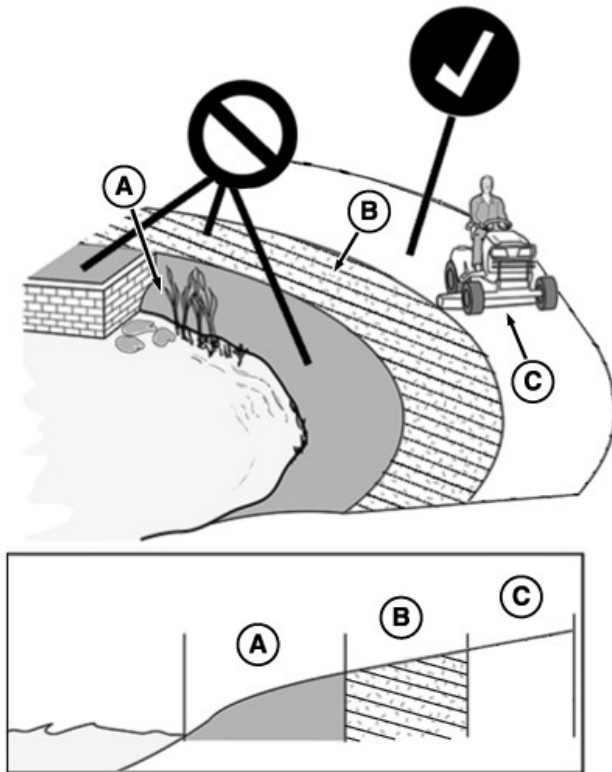

GX100106—UN—01FEB20

- Terrain hazards such as ditches and drop-offs are a factor related to loss of control and tip-over

accidents, which can result in serious injury or death. Use caution and common sense when operating near terrain hazards.

- Do not mow or operate the machine in areas adjacent to hazards that can cause the machine to roll over. If a wheel goes over an edge or if the edge breaks away, the machine can suddenly lose traction, slide, and/or roll over.
- Hazards (A) include but are not limited to ditches, drop-offs, embankments, or areas near bodies of water.
- Maintain a buffer area (B) at least as wide as the machine between hazards (A) and the mowing area (C). Do not mow or operate the machine in the hazard area or buffer area.
- Only mow or operate in the mowing area (C). Do not exceed the recommended slope operating angle. Refer to the Slope Limits section.

SDHTXN6,1745840980137-19-04JUN25

Prevent Fires



TS227—UN—15APR13

- Do not mow tall, dry grass or through piles of leaves. Combustible materials can contact hot components and increase the risk of fire.
- Debris can build up anywhere on the machine, especially on horizontal surfaces. While using your machine, periodically check for and remove debris, especially in dry or heavy debris conditions, such as when collecting leaves.
- After operating, completely remove any combustible materials from equipment before storing. Use compressed air, a leaf blower, or water to keep the machine clean.
- Allow machine to cool in an open area before storing. Do not park machine near flammable materials, such as straw, mulch, cloth, or chemicals. Do not park near an open flame or other sources of ignition, such as a water heater or furnace.
- Excess lubrication or fuel/oil leaks or spills on the machine can also provide collection sites for debris. Promptly cleaning up spills and repairing leaks reduces the potential for debris collection.

- Refer to the Machine Cleanout section for more information on checking for debris buildup and locations to inspect.
- Always park the machine safely before cleaning or servicing a machine. See the Parking Safely section.

OUO2005.0000787-19-15FEB20

Parking Safely

Always apply the park brake and remove the key or key pin before leaving the machine unattended. Children or others may attempt to move or operate an unattended machine.

- Bring the machine to stop on a level surface.
- Disengage mower blades or other attachments.
- Lower attachments to the ground.
- Apply the park brake.
- Shut the machine OFF.
- Remove the key or key pin.
- Wait for all moving parts to stop before you leave the seat.
- Disconnect battery before maintenance.

OUO2005.0000788-19-12APR23

Additional Safety Information

Towing Loads Safely

- Stopping distance increases with speed and weight of towed load. Travel slowly and allow extra time and distance to stop.
- Total towed weight must not exceed Towing Capacity stated in Specifications of this manual.
- Excessive towed load can cause loss of traction and loss of control on slopes. Reduce towed weight when operating on slopes.
- Never allow children or others in or on towed equipment.
- Use only approved hitches. Tow only with a machine that has a hitch designed for towing. Do not attach towed equipment except at the approved hitch point.
- Towed equipment increases the risk of rollover on slopes. Refer to the Operating on Slopes and Near Terrain Hazards section for more information.
- Do not turn sharply. Use additional caution when turning or operating on adverse surface conditions. Use care when reversing.

Safe Transportation

Follow instructions in the Transporting Machine on Trailer section.

- Use a full-width loading ramp at least 30 cm (12 in) wider than the machine, never two separate ramps.

Service and Maintenance

- Proper service and maintenance of the machine is essential.
- Keep all parts in good condition, keep all nuts and bolts tight, and repair any damage immediately. Stop and inspect the machine immediately if you strike an object.
- Ensure that all safety devices, discharge chute, and grass catcher components are in good condition and replace when necessary.
- Understand service procedures thoroughly before working on the machine. If you do not understand the service procedures or are uncomfortable working in your machine, contact your John Deere dealer or other service provider.
- Disconnect the battery or all spark plug wires before servicing the machine. Disconnect negative terminal first and positive last. Install positive terminal first and negative last.
- Some components could have stored energy in springs or hydraulic components. Servicing procedures described in the Service section describe how to perform service and maintenance tasks safely.
- Support any machine elements that must be raised for service work. Use jack stands or service locks to support components when needed.

Disposing of Waste Products and Chemicals

- Waste products, such as used oil, fuel, coolant, brake fluid, and batteries can harm the environment and people.
- Do not use beverage containers for waste fluids – someone can mistakenly drink from them.
- A Safety Data Sheet (SDS) provides specific details on chemical products: Physical and health hazards, safety procedures, and emergency response techniques. The seller of the chemical products used with your machine is responsible for providing the SDS for that product.
- To learn how to recycle or properly dispose of waste products generated from service, see your local recycling center, John Deere dealer, or other service provider. If you wish to discard the machine, contact your local recycling center, John Deere dealer, or other service provider.

OUO2005.0000789-19-17OCT25

Machine Cleanout

General Cleaning Guidelines

Machine must be inspected periodically throughout the day. Buildup of debris must be removed to ensure proper machine function and to reduce the risk of fire. Frequency of these inspections and cleanings vary depending on a number of factors including operating conditions, machine configuration, operating speeds, and weather conditions. Inspections and cleanings may be required multiple times throughout the day particularly in dry, hot, and windy conditions.

IMPORTANT: Avoid damage! Regular and thorough cleaning of machine combined with other routine maintenance procedures listed in the Operator's Manual greatly reduce the risk of fire, downtime, and improve machine performance.

Besides proper maintenance, the condition of the material being handled is the most significant factor contributing to fires. Dry, light, and fluffy materials that can create a dust cloud are the most likely to catch fire. Debris can accumulate in various areas especially on horizontal surfaces. Conditions such as wind speed and direction can change where the material accumulates. Be aware of these changing conditions and adjust your cleaning schedule and practices to ensure proper machine function and to reduce the risk of fire.

Always follow all safety procedures posted on the machine and in the Operator's Manual. Before carrying out any inspection or cleaning, always shut OFF engine, set park brake, and remove key.

The entire machine should be inspected, with extra attention given to the areas noted below.

SR99263,000028F-19-15APR20

Cleanout Areas

Primary areas that must be inspected and cleaned on the machine include (see Safety Label section):

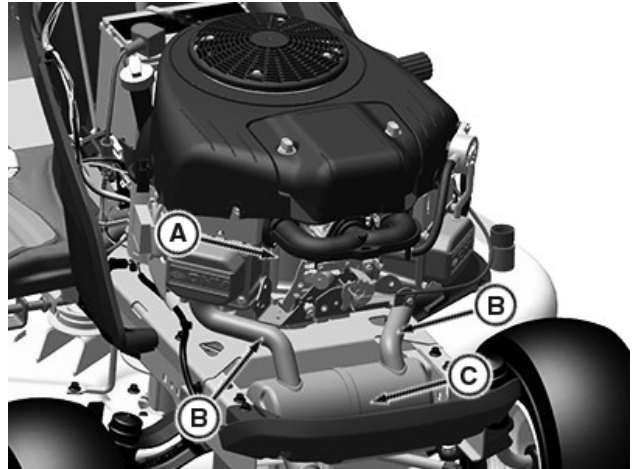

APY33760—UN—26MAR20

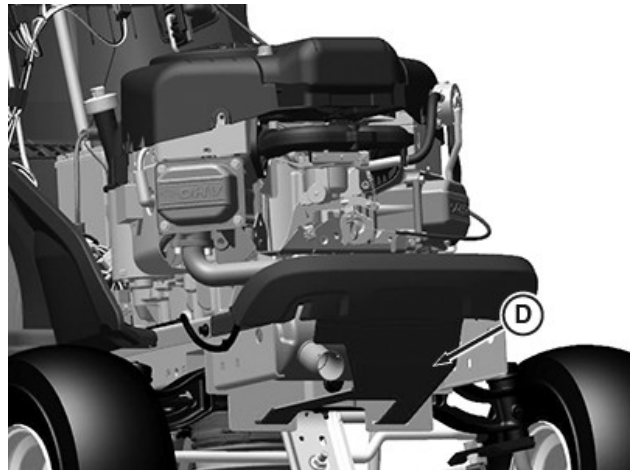

APY33761—UN—26MAR20

1. Exhaust manifold (A), muffler pipe (B), muffler (C), and muffler shield (D).

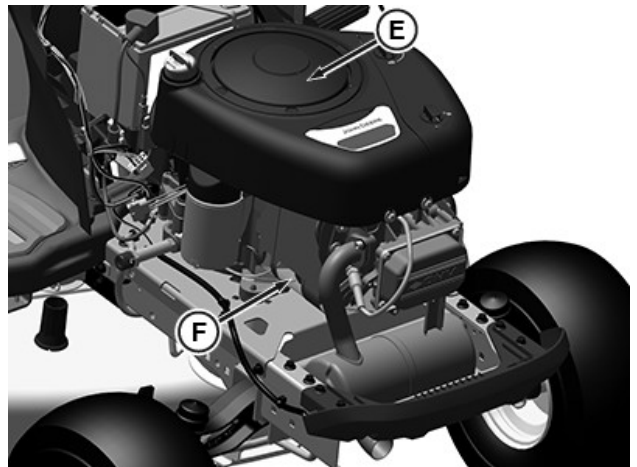

APY36199—UN—28JUL20

2. Engine intake screens (E), cooling fins (F), and oil cooler (if equipped).

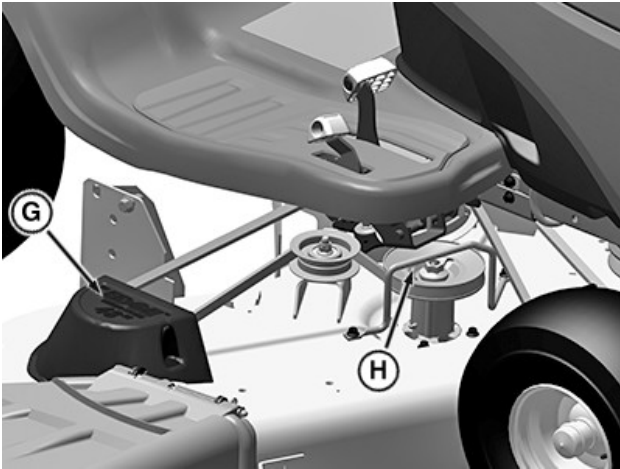

PY43269—UN—29MAY17

3. Top of mower deck, under shields (G), including spindle (H) and belt areas.

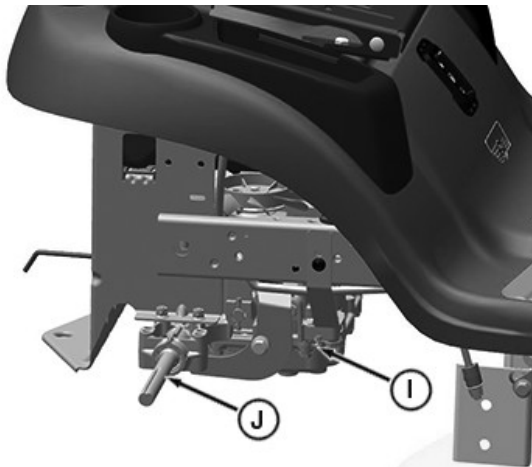

APY36511—UN—14MAY20

Shown with Wheel Removed

4. On or near transmission (I) and driveline (J).

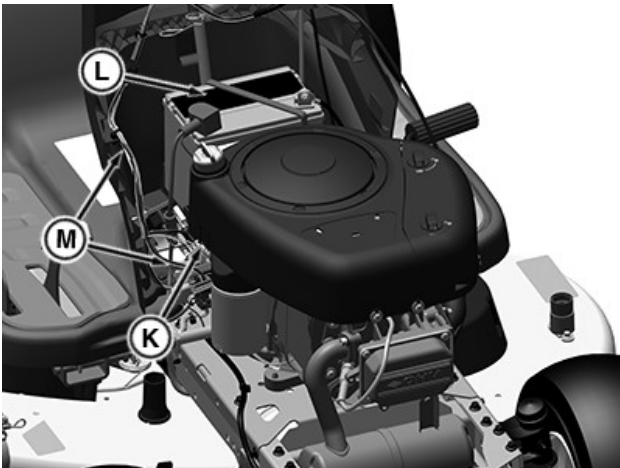

APY36151—UN—08APR21

5. Under left side panel near fuse block (K) and all wiring, including the battery (L) and related wiring harnesses (M).

SR99263,00002FA-19-28JUL20

Operating Controls

Operator's Station Controls

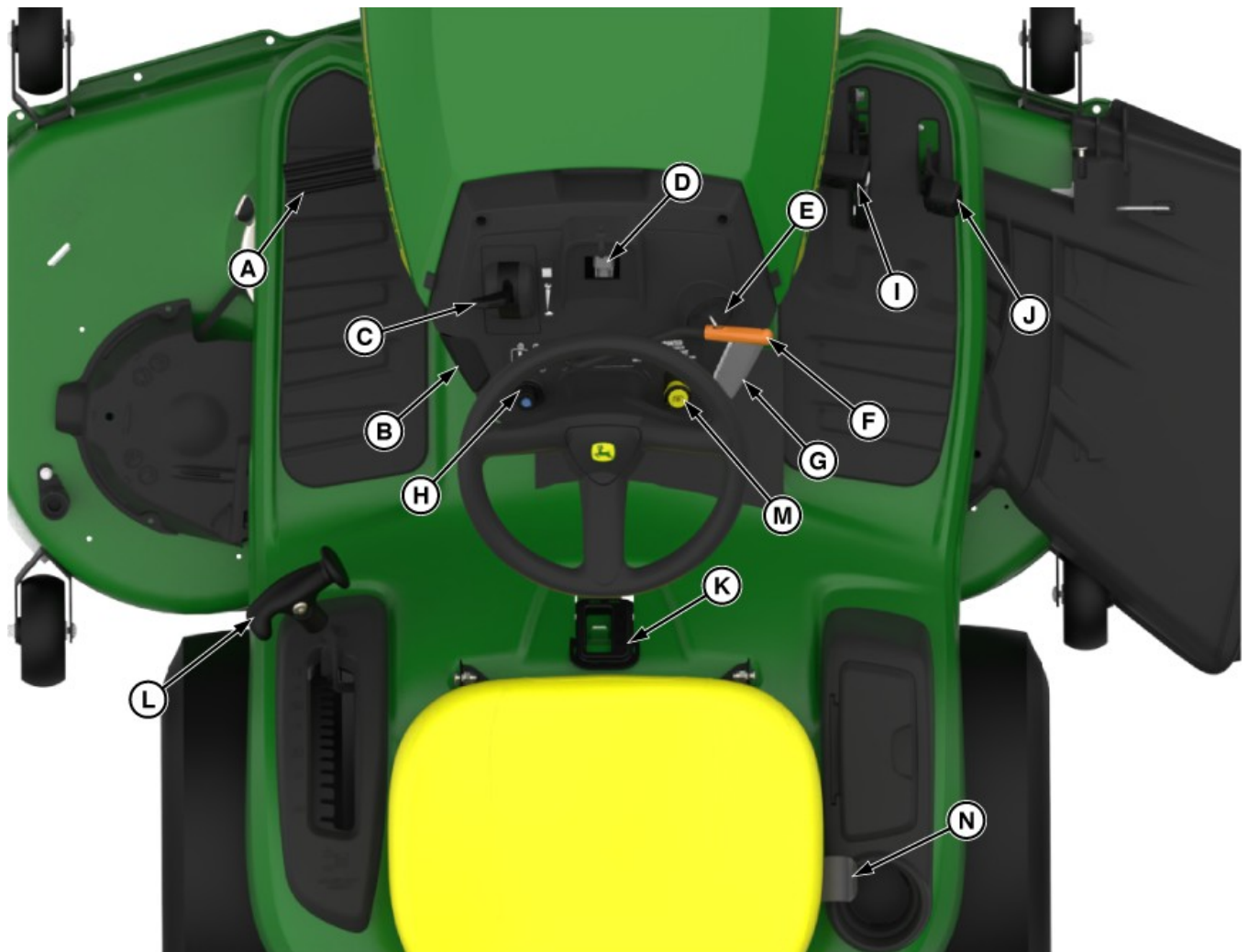

GX663369—UN—22MAY25

- A—Brake Pedal
- B—Park Brake Lock Lever
- C—Throttle/Choke Lever
- D—Hourmeter/MowerPlus Fuel Gauge (if equipped)
- E—Key Switch
- F—Attachment Engagement Lever, Manual PTO (if equipped)
- G—Cruise Control Lever (if equipped)

- H—Reverse Implement Option (RIO) Switch
- I—Forward Travel Pedal
- J—Reverse Travel Pedal
- K—Cover/Fuel Level Window (if equipped)
- L—Attachment Lift Lever
- M—Attachment Engagement Switch, Electric PTO (if equipped)
- N—Seat Adjust Lever

SDHTXN6,1745841319178-19-22MAY25

Operating

Daily Operating Checklist

- Check/test safety systems.
- Check tire pressure and brakes.

IMPORTANT: Avoid damage! Using stale, contaminated, or improper fuel can result in engine and fuel system damage. Repairs caused by stale, contaminated, or improper fuel are not covered by warranty.

- Check fuel level. (See Service Miscellaneous section, using proper fuel and stabilizer.)
- Check engine oil level.
- Remove grass and debris from engine compartment and muffler area, and on top of mower deck, before and after operating machine.
- Clean air intake screen.
- Check below machine for fluid leaks.
- Check/tighten any loose hardware.

SR99263,0000293-19-15APR20

Adjusting Seat

1. Sit on seat.



APY34607—UN—31MAR20

2. Lift up on adjustment lever (A) on right side of seat.
3. Lean forward and slide seat forward or rearward to desired position. Do not lean back on top of seat to push rearward.
4. Release seat adjustment lever to lock in position.

SR99263,0000306-19-01APR20

Adjusting Cutting Height

Cutting height is adjusted from approximately 25—100 mm (1—4 in) in 6.4 mm (1/4 in) increments. When mower deck is in the transport position, cutting height is approximately 100 mm (4 in).

Detents allow the adjustment lever to be positioned at each indicated mower setting, as well as the mid-point between each setting.

Mower Setting	Approximate Cutting Height
1	25 mm (1 in)
–	32 mm (1-1/4 in)
–	38 mm (1-1/2 in)
–	44 mm (1-3/4 in)
2	50 mm (2 in)
–	57 mm (2-1/4 in)
–	65 mm (2-1/2 in)
–	70 mm (2-3/4 in)
3	75 mm (3 in)
–	83 mm (3-1/4 in)
–	90 mm (3-1/2 in)
–	95 mm (3-3/4 in)
4 (Transport)	100 mm (4 in)

1. Put the attachment lift lever into the slot near desired cutting height.
2. Adjust mower deck wheels.

Transporting or Getting on and off Machine

- Pull the attachment lift lever all the way back to transport position or 100 mm (4 in) cutting height.

JS86122,00003BF-19-07MAY21

Checking and Adjusting Mower Deck Level

⚠ CAUTION: Avoid injury! Rotating blades are dangerous. Before adjusting or servicing mower:

- Disconnect spark plug wires or battery negative (-) cable to prevent engine from starting accidentally.
- Always wear gloves when handling mower blades or working near blades.

NOTE: Mower deck wheels should not contact the ground when leveling the mower deck.

Method One

1. Make sure machine is on a flat, level surface.
2. Park machine safely. (See Parking Safely in the Safety section.)
3. Check that tires are inflated to correct tire pressure. Tire pressure is marked on the side of the tire.
4. Raise deck to highest position.

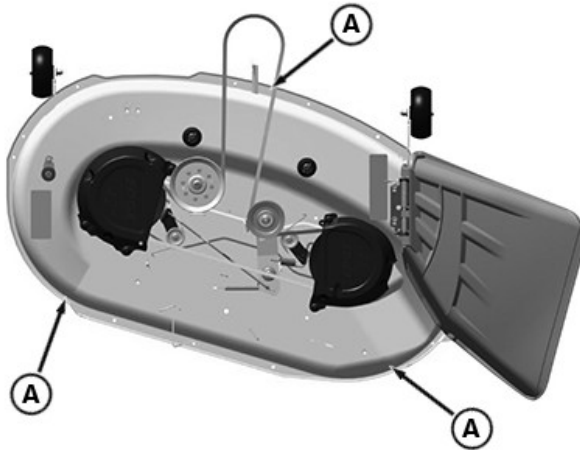

APY18570—UN—10JUL20
42 in (107 cm) Mower Deck is Shown.

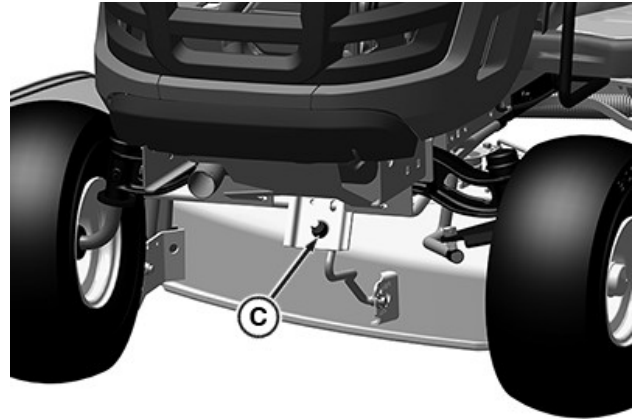

APY36154—UN—10JUL20
42 in (107 cm) Mower Deck is Shown.

5. Place three short 51 mm (2 in) blocks of wood under the edges (A) of the mower deck.
6. Lower mower deck to the 63 mm (2.5 in) cutting height position.
For S130 models, lower deck to 57 mm (2-1/4 in) cutting height position.
7. Check that the mower deck is level and lightly touching each of the three wooden blocks.

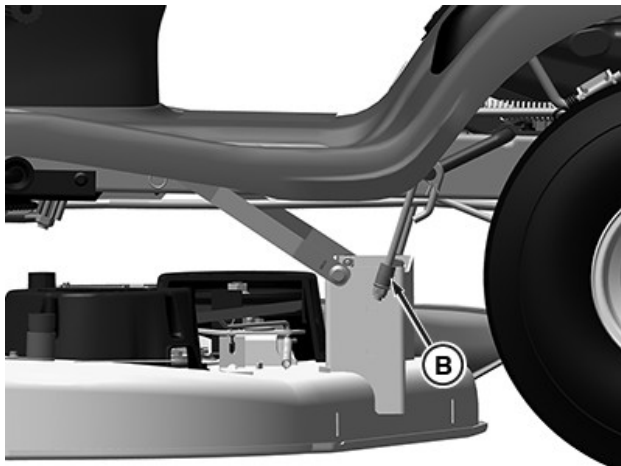

APY36153—UN—24JUL20

- If the rear of the mower deck is not touching the rear blocks, or is sitting heavily on the blocks, adjust the rear lift links by turning the leveling nut (B) on each lift link. The blocks should be able to easily slide in and out beneath the mower deck when the mower deck is correctly adjusted.

- If the front of the mower deck is not lightly touching the front block, adjust the front draft arm by turning the nut (C).
8. Raise the cutting height to the next highest position and remove the three wooden blocks.
 9. Turn the nut (C) on the front draft arm counterclockwise 1-2 full turns so that the front of the deck is 3-6 mm (1/8-1/4 in) lower than the rear. This adjustment prevents “double cutting,” which wastes horsepower and causes brown grass tips.

Specification

Mower Deck, Front-to-Back—Height	1/8-1/4 in (3-6 mm)
--	---------------------

Method Two

NOTE: An optional mower deck leveling gauge (AM130907) is available for purchase. It allows for precision mower deck leveling by measuring mower deck level at the blade tips.

1. Make sure that machine is on a flat, level surface.
2. Park machine safely. (See Parking Safely in the Safety section.)
3. Inflate tires to the correct pressure.
4. Move mower lift handle to preferred cutting height.
5. Measure mower deck level (side-to-side).



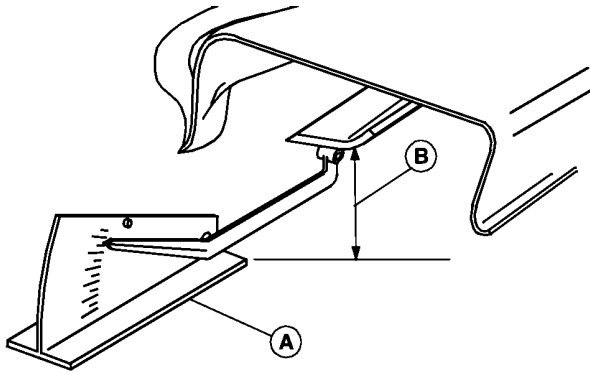

GXAL41983—UN—04MAR13

A convenient Leveling Gauge (A) (AM130907) is available for purchase.

- a. Position mower blades as follows and measure from each outside blade tip (B) to the level surface.

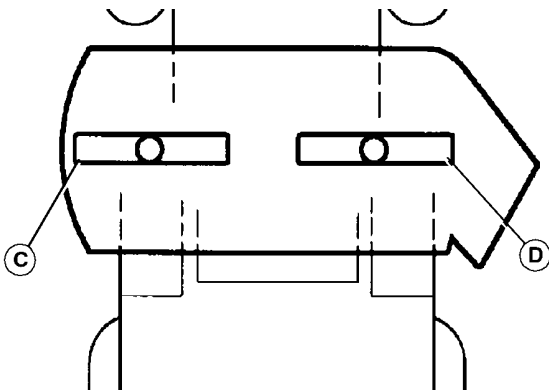

GXAL41984—UN—04MAR13

Two Blade Deck is Shown.

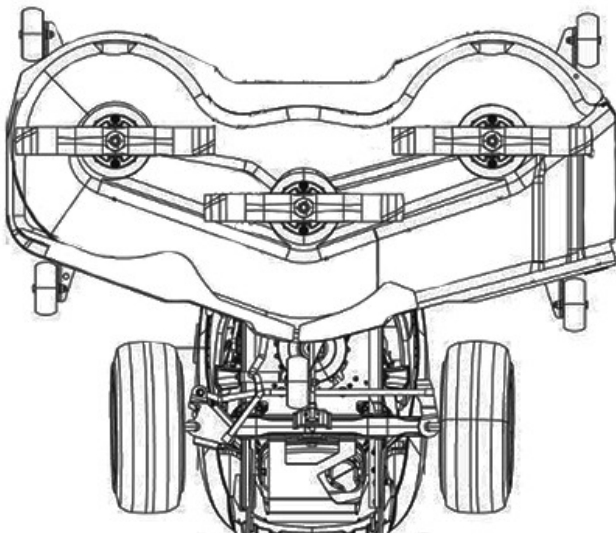

APY08950—UN—17JUL18

Three Blade Deck is Shown.

- b. Turn left blade (C) as shown. Hold drive belt and turn right blade (D) as shown. Take measurement for both blades.

The difference between blade measurements must not be more than specified distance.

Specification

Mower Deck Blade Outside Tips to Ground

(Difference)—Distance. 1/8 in (3 mm)

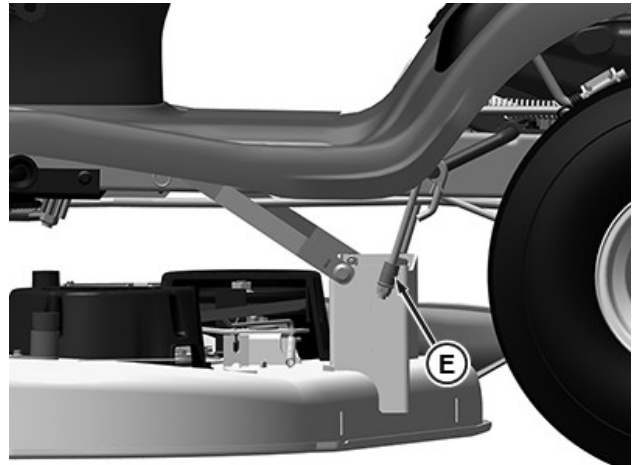

APY36155—UN—24JUL20

- c. Adjust mower deck level, if necessary, by turning rear nuts (E) clockwise to raise the side of the mower deck or counterclockwise to lower the mower deck.

6. Measure mower level (front-to-rear).

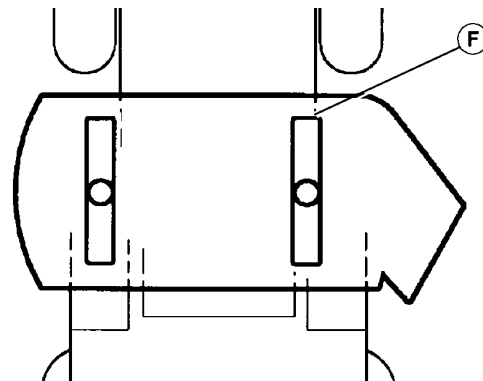

GXAL41986—UN—04MAR13

- a. Turn right blade (F) so blade tip points straight forward.
- b. Measure from blade tip to the surface. Take measurement for both blades.

The front blade tip must be specified distance lower than rear blade tip.

Specification

Mower Deck Blade Outside Tips to Ground

(Difference)—Distance. 3–6 mm (1/8 -1/4 in)



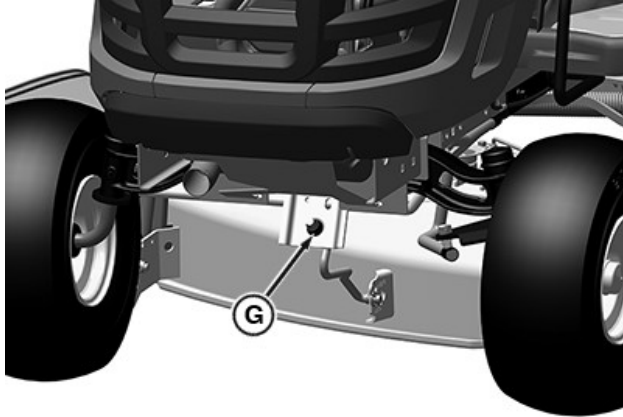

APY36156—UN—10JUL20

42 in (107 cm) Mower Deck is Shown.

- c. Adjust mower deck level, if necessary, by turning the nut (G) counterclockwise to lower the front of deck or clockwise to raise front of deck.

SR99263,00002EA-19-17OCT25

Adjusting Mower Deck Wheels

IMPORTANT: The mower deck can be damaged if mower wheels are adjusted wrong:

- Bottom of wheels should be approximately 3 to 13 mm (1/8 to 1/2 in) from the ground.
- If mowing at 75 mm (3 in) height of cut or higher set the anti-scalp wheels in their lowest position

1. Park machine safely. (See Parking Safely in the SAFETY section.)
2. Inflate tires to the correct pressure.
3. Lower mower deck to the desired mowing position.

NOTE: Bottom of wheels should be approximately 3-13 mm (1/8-1/2 in.) from the ground.

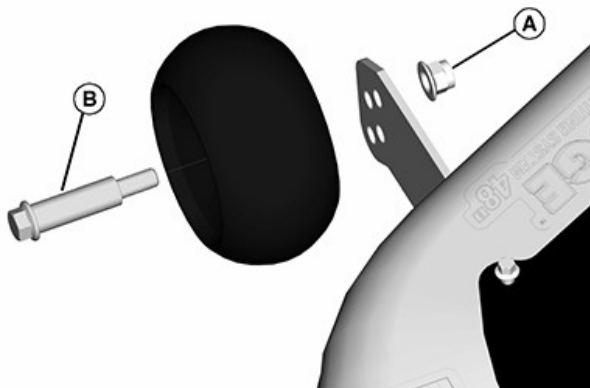

GXAL41988—UN—04MAR13

4. Check each mower wheel position. Remove nut (A) and bolt (B), and move mower wheel to proper hole.

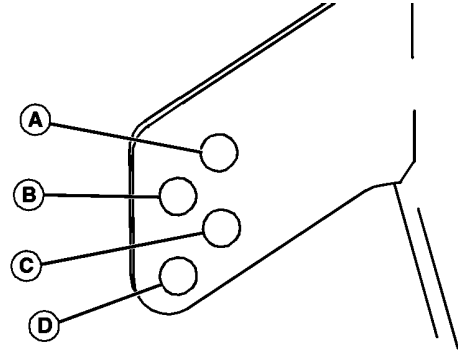

GXAL41989—UN—04MAR13

- A—38 mm (1.5-In.) or less
- B—51 mm (2-In.)
- C—64 mm (2.5-In.)
- D—76 mm (3-In.) and above

5. Install bolts and nuts to lock wheels in position. Tighten nuts to specifications.

Specification

Mower Deck Wheel	
Nut—Torque	25 lb·ft (34 N·m)

JS86122,0000312-19-11JUL14

Testing Safety Systems

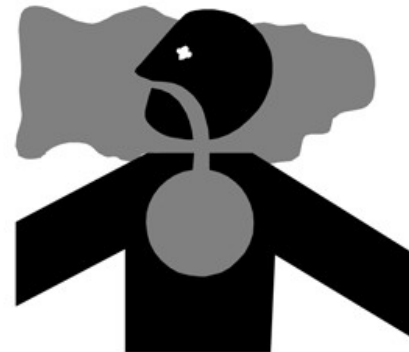

MXAL42804—UN—09APR13

CAUTION: Avoid injury! Engine exhaust fumes contain carbon monoxide and can cause serious illness or death.

Do not run an engine in an enclosed area, such as a garage, even with doors or windows opened.

Move the machine to an outside area before running the engine.

The safety systems installed on your machine should be checked before each machine use. Be sure that you have read the machine operator's manual and are familiar with the operation of the machine before performing these safety system checks.

Use the following checkout procedures to check for normal operation of machine.

If there is a malfunction during one of these procedures, do not operate machine. **See your dealer or other service provider for service.**

Perform these tests in a clear open area. Keep bystanders away.

SR99263,0000296-19-29JUL25

Testing Park Brake Switch

1. Park machine safely. (See Parking Safely in the SAFETY section.)
2. Sit on seat.
3. Unlock the park brake.
4. Try to start engine.

Result: Engine must not turn over. If engine turns over, there is a problem with your safety interlock circuit.

MP47322,00F4638-19-09APR19

Testing Park Brake

1. Park machine safely. (See Parking Safely in the Safety section.)
2. Lock the park brake.
3. Pull out on bypass control valve rod to engage.
4. Try to push machine manually.

Result: Park brake must prevent machine from moving. If machine moves, the park brake requires adjustment.

SR99263,0000318-19-06APR20

Testing Attachment Engagement Switch or Lever

 **CAUTION: Avoid injury! The mower blades should stop in approximately five seconds when the mower or PTO is disengaged.**

If you believe that your blades may not be stopping in that period of time, take your machine to your dealer or other service provider where they can safely check and service your machine.

1. Park machine safely. (See Parking Safely in the Safety section.)
2. Sit on seat.
3. Lock the park brake.
4. Engage mower:

- On models with electric attachment engagement switch, pull up switch.
- On models with mechanical attachment engagement lever, push lever forward.

5. Try to start engine.

Result: Engine must not start. If engine starts, there is a problem with your safety interlock circuit.

SR99263,0000299-19-29JUL25

Testing Seat Switch

1. Park machine safely. (See Parking Safely in the SAFETY Section.)
2. First test:
 - a. Lock park brake.
 - b. Start engine.
 - c. Move throttle lever up to maximum engine speed.
 - d. Engage mower.
 - e. Raise up off seat. Do not get off machine.

Result: Engine and mower blades should stop. If engine and mower blades do not stop, there is a problem with your safety interlock circuit.

3. Second test:
 - a. Disengage mower.
 - b. Start engine.
 - c. Unlock park brake.
 - d. Raise up off seat. Do not get off machine.

Result: Engine should stop. If engine does not stop, there is a problem with your safety interlock circuit.

4. Third test:
 - a. Lock park brake.
 - b. Disengage mower.
 - c. Start engine.
 - d. Raise up off seat. Do not get off machine.

Result: Engine should continue to run. If engine stops, there is a problem with your safety interlock circuit.

MP47322,00F463B-19-19MAR13

Testing Reverse Implement Option (RIO)

1. Park machine safely. (See Parking Safely in the Safety section.)
2. Start engine.

- Engage attachment engagement switch or lever to start attachment.

CAUTION: Avoid injury! Rotating blades are dangerous. Children or bystanders may be injured by runover and rotating blades.

Before backing up, carefully check the area around the machine.

- Look behind the vehicle to be sure that there are no bystanders.
- Begin reverse travel by depressing reverse pedal.

Result: Attachment and engine should stop operation. If attachment or engine continues to operate as machine begins travel in reverse, do not continue to operate machine. If Engine or attachment continues to operate in reverse, then contact an authorized service center.

SR99263,000029A-19-16JUL20

Using the Park Brake

CAUTION: Avoid injury! Children or bystanders may attempt to move or operate an unattended machine.

Always lock the park brake and remove the key before leaving the machine unattended.

Locking Park Brake:

- Push and hold brake pedal down.
- Pull park brake lever up to lock park brake.
- Release brake pedal. Pedal should stay down and park brake lever should stay locked.

Unlocking Park Brake:

- Push and hold brake pedal down.
- Push park brake lever down to unlock park brake.
- Release brake pedal.

SR99263,000029B-19-03APR20

Checking Fuel Level (If Equipped)



APY36157—UN—10JUL20

Check fuel level in fuel tank (A).

MG39705,00004AA-19-30JUN20

Using Hourmeter and MowerPlus™ Fuel Gauge (If Equipped)

Using Hourmeter



APY36158—UN—10JUL20

- The hour meter (A) shows the number of hours the engine has run.
- Follow the service timetable on the maintenance schedule located under the hood and centered toward the rear of the machine. For specific service procedures, see the Service section of this manual.
- The hour meter cannot be reset.
- The hour meter display will always be on.
- The decimal point flashes while the hour meter is accumulating time.

Using MowerPlus™ Fuel Gauge (If Equipped)

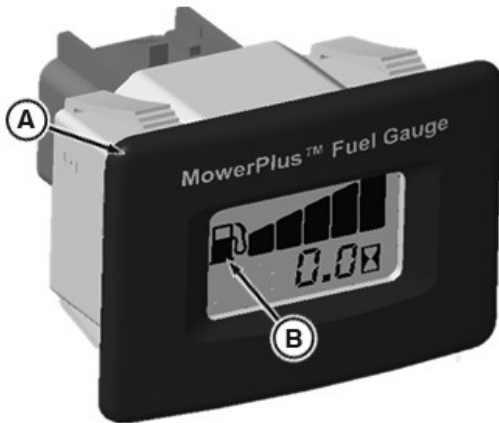

APY33785—UN—24JUL20

1. The hour meter (A) shows the number of hours the engine has run. The hour meter is always visible and active, it cannot be reset.
2. Fuel level (B) indicated by the graph by five segments in increasing height. When fuel tank has emptied to approximately 20%, the last segment flashes indicating approximately 30 minutes of fuel remaining.

MG39705.00004AB-19-27JUL20

Using Key Switch and Headlights

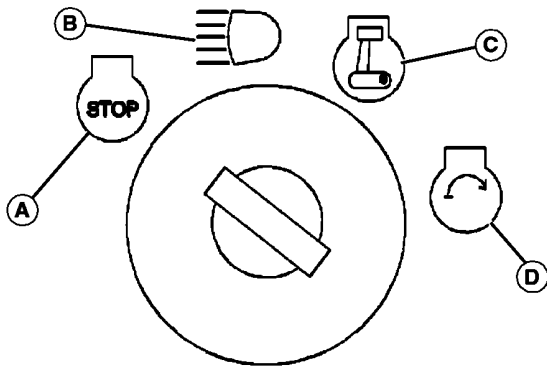

GXAL41992—UN—04MAR13

- A—STOP Position
- B—HEADLIGHTS ON Position
- C—RUN Position
- D—START Position

Engine Off

NOTE: Headlights will drain the battery rapidly if key switch is left in headlights on position (B) with the engine off.

- To turn on headlights, turn the key switch to HEADLIGHTS ON position (B).
- To turn off headlights, turn the key switch to STOP position (A).

Engine On

- To turn on headlights, start engine, then turn key switch from RUN position (C) to HEADLIGHTS ON position (B).
- To turn off headlights, turn the key switch from HEADLIGHTS ON position (B) to RUN position (C).

MX00654.000039A-19-25APR19

Starting the Engine

1. Operator must sit on the seat.
2. Disengage attachment engagement lever / switch. (See Engaging and Disengaging Mower in the Operating section.)
3. Fully depress the brake pedal.

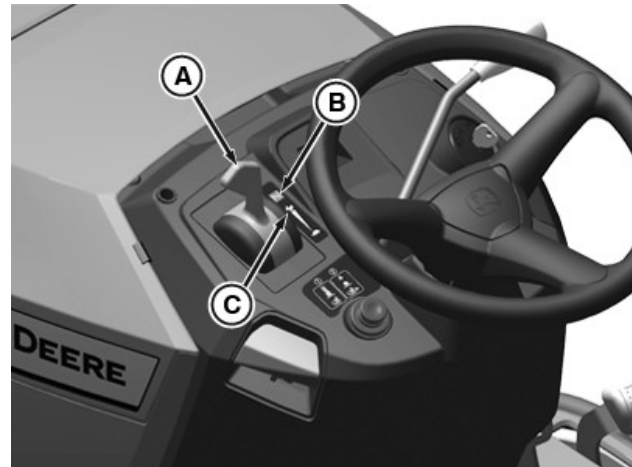

APY38190—UN—07JUL20

4. Push throttle lever (A) forward to full throttle position (C).
5. Turn ignition to START (not more than 5 seconds).
6. If engine is cold:
 - Push throttle lever (A) into choke area (B) and hold.
 - Turn ignition to START (not more than 5 seconds).
 - Release choke to full throttle position.

NOTE: Run engine at full throttle when operating mower or other attachments.

SR99263.000029E-19-05OCT20

Idling the Engine

Unnecessary engine idling may cause engine or transmission damage. Excessive idling can cause engine overheating, carbon build-up, and poor performance.

Idling or low throttle operation while mowing, climbing hills, or towing could result in transmission overheating. Always operate at full throttle once the engine is warm.

Do not operate machine with hood open. Hood must be closed for proper engine cooling and exhaust.

- Engine is air cooled and needs a large volume of air to keep cool. Keep air intake screen on top of engine clean.
- Keep hood closed when engine is idling.

SR99263,0000039-19-10JUL18

Stopping the Engine

IMPORTANT: Avoid damage! Do not stop the engine by moving choke control to the choke position. Backfire, fire or engine damage can occur. Follow recommended procedure for stopping engine.

1. Let engine run at high throttle without load for a few seconds.
2. Turn key to STOP position. Engine will stop and headlights will turn off.
3. Remove key.
4. Lock the park brake.

SR99263,000029D-19-03APR20

Using Travel Controls on Hydrostatic Transmission

CAUTION: Avoid injury! Children or bystanders may be injured by runover and rotating blades. Before traveling forward or rearward:

- Carefully check the area around the machine.
- Disengage the mower before backing up.

Travel Forward



APY33767—UN—06APR20

Tractor with PTO Lever

- Push down the forward travel pedal (A).

Travel in Reverse

NOTE: Any operating attachment and the engine stop as the reverse motion pedal is pressed with attachment engaged.

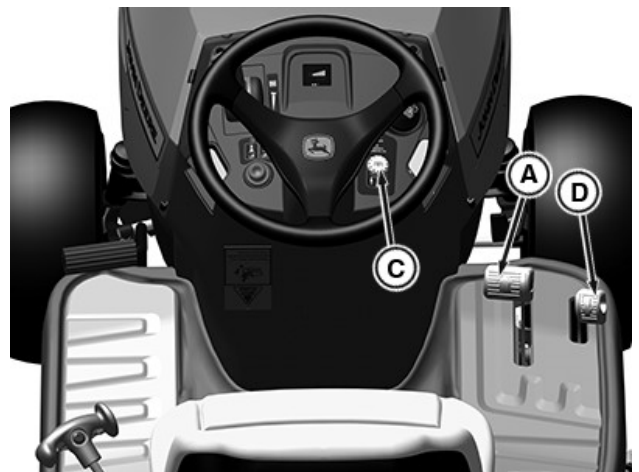

APY36160—UN—10JUL20

Tractor with PTO Switch

1. Disengage attachment:
 - On models with mechanical attachment engagement lever (B), pull lever back to the off position.
 - On models with electric attachment engagement switch, push switch in location (C) (not shown above) down to the off position.
2. Look behind the machine to be sure there are no bystanders nearby.
3. Slowly push down the reverse travel pedal (D).

Stopping

1. Remove foot from travel pedal.
2. Depress brake pedal.

Emergency Stopping

1. Remove foot from travel pedal.
2. Depress brake pedal.
3. Turn key switch to stop (Off) position. Do not release brake pedal until all moving parts have stopped.
4. If possible, lock the park brake.

SR99263,00002FF-19-01JUL20

Using The Reverse Implement Option (RIO)

⚠ CAUTION: Avoid injury! Children or bystanders may be injured by runover and rotating blades. Before traveling forward or rearward:

- Carefully check the area around the machine.
- Disengage the mower before backing up.

NOTE: Backing up while the mower is engaged is strongly discouraged. The Reverse Implement Option should be used only when operating another attachment or when the operator deems it necessary to reposition the machine with the mower engaged.

1. Stop forward travel.
2. Look behind the machine to be sure there are no bystanders.



APY36159—UN—10JUL20

3. Push and hold in the reverse implement switch (A) while depressing reverse pedal slightly.

NOTE: If the engine and mower stop while repositioning the machine, return the attachment engagement lever/switch to the off position. Start engine and engage mower. Begin again with Step 2.

4. Release the reverse implement switch (A) and reposition the machine as the machine begins to move rearward.
5. Resume forward travel. The mower should continue operating.
6. Repeat procedure to position the machine again.

SR99263,00002EB-19-01JUL20

Using Cruise Control (If Equipped)

⚠ CAUTION: Avoid injury! Do not use cruise control when going down hills. Machine speed will increase. Operate machine in a large, open area to learn how the cruise control works.

Use cruise control when you want to maintain travel speed without having to hold the forward travel pedal down. Cruise control operates only for forward travel.

Engage Cruise Control

1. Push forward pedal down until you reach desired travel speed.
2. Pull cruise control lever up and release forward pedal to lock the cruise control.

Disengage Cruise Control

- Depress brake pedal, tap on forward pedal or push cruise control lever down to the off position.

SR99263,00002EC-19-28JUL25

Engaging and Disengaging Mower

NOTE: Put attachment lift lever in transport position to transport machine or when parking machine.

1. Start engine and run at half speed for a couple of minutes to warm up.
2. Lower mower deck to desired cutting height position.

NOTE: Throttle lever should be at full throttle position before engaging mower to avoid stalling engine.

3. Push throttle lever up to the full throttle position.
4. Engage mower.
 - On models with electric attachment engagement switch: Pull up switch.
 - On models with mechanical attachment engagement lever: Push lever forward.

NOTE: The mower and engine stops as the reverse foot pedal is depressed.

5. Disengage mower blades before moving in reverse or stopping engine.
 - Machines with mechanical attachment engagement lever: Pull lever back.
 - Machines with electric attachment engagement switch: Push down switch.

SR99263,0000338-19-12MAY20

Using Wash Port to Clean Mower Deck

NOTE: Follow this procedure after each use to prevent buildup and remove corrosive lawn chemicals.

1. Park machine safely. (See Parking Safely in the Safety section).



GXAL41997—UN—04MAR13

2. Attach quick-coupler to garden hose.
3. Attach garden hose with quick-coupler to wash port (A) on the mower deck.
4. Turn on water.
5. Start engine.
6. Run at full throttle.
7. Engage mower blades.
8. Flush water under deck for approximately one minute.
9. Disengage mower blades.
10. Stop engine.
11. Turn off water and remove garden hose and quick-coupler from wash port.
12. Remove quick-coupler from garden hose and store for future use.

OOU1023,00001B0-19-01MAR13

Unplugging Mower, Bagger, or Material Collection System

- ⚠ CAUTION: Avoid injury! Do not attempt to unplug attachment with the machine running.**
- Rotating blades are dangerous. Shut off the engine and remove the key before getting off the seat to inspect the machine and attachment.
 - Thrown objects can cause serious injury. Make sure that all machine parts are stopped before raising hopper top or removing chutes.

Checking for Plugging While Driving

If grass builds up in the front of the mower discharge chute, check for plugged chute or problems with blower assembly (if equipped).

If there is a trail of clippings behind mower or clippings blow to the side, check for plugged chute, full collector bags, or problems with blower assembly.

Removing Debris from Inspection Points:

- ⚠ CAUTION: Avoid injury! Do not use hands or feet to clear plugged mower deck or blower assembly. Stored energy can cause blades to rotate.**
1. Park machine safely. Wait for all moving parts to stop before getting off to inspect machine.
 2. Open hopper cover. Check chute outlet.
 3. Remove chute from the mower deck or blower assembly. Check chute inlet.
 4. Check under the mower deck for debris.

MP47322,00F4646-19-10JUL20

Moving Machine by Hand

- ⚠ CAUTION: Avoid injury! When the bypass valve is open, the machine has unrestricted motion.**
- Do not open the bypass valve when the machine is stopped on an incline to prevent it from going downhill out of control.

IMPORTANT: Avoid damage! Transmission damage may occur if the machine is towed or moved incorrectly:

- Move machine by hand only.
- Do not use another vehicle to move machine.
- Do not tow machine.

1. Unlock the park brake.



APY36161—UN—10JUL20

2. On hydrostatic models: Pull out on bypass valve control rod (A).
3. Push machine to desired location.

IMPORTANT: Avoid damage! Hydrostatic transmission might be damaged if the bypass valve control rod is not pushed back to operating position before attempting to start the engine. Do not start or operate the machine with the bypass valve control rod in the pulled-out position.

4. Push bypass valve control rod back in.
5. Lock the park brake.

MG39705.00004EE-19-28JUL20

Transporting Machine on Trailer

NOTE: Trailer capacity must exceed combined machine weight and attachment weight. (See Specifications section in Operator's manual.)

Be sure the trailer has all necessary lights and signs required by law.

CAUTION: Avoid injury! Use extra care when loading or unloading the machine onto a trailer or truck.

- Park trailer on a level surface.
- Use of a trailer with sides is recommended.
- Keep wheels away from drop-offs and edges.
- Back slowly and in a straight line.
- Close fuel shut-off valve, if your machine is equipped.
- Do not secure machine using optional bumper as this can dislodge during transport.

IMPORTANT: Avoid damage! Transporting a machine on a trailer or on a truck bed at high speeds can result in hood or engine cover raising and possibly coming off machine if not secured.

- Position machine on trailer so hood or engine cover opens from rear of trailer to prevent wind from blowing hood or cover open.
- Secure hood or engine cover with existing machine locks or latches.
- Secure hood or engine cover with tie down straps if no locks or latches exist.

1. Park trailer on a level surface.
2. Raise mower deck, if installed, before driving machine onto trailer.
3. Drive machine onto heavy-duty trailer. Position machine on trailer so hood or engine cover will not raise in wind while being transported.
4. Lower mower deck completely.
5. Lock park brake.
6. Turn off machine and remove key.

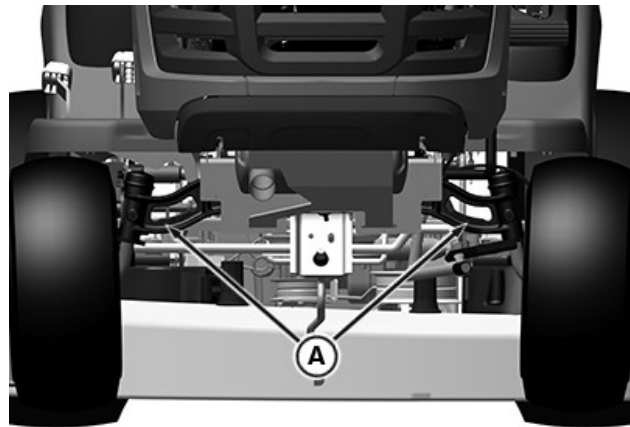

APY36162—UN—10JUL20

7. Secure front of machine at both sides of the axle at points (A) to trailer with heavy-duty straps, chains, or cables. Straps must be directed down and outward from machine.

IMPORTANT: Avoid damage! Do not secure machine using transmission housing.

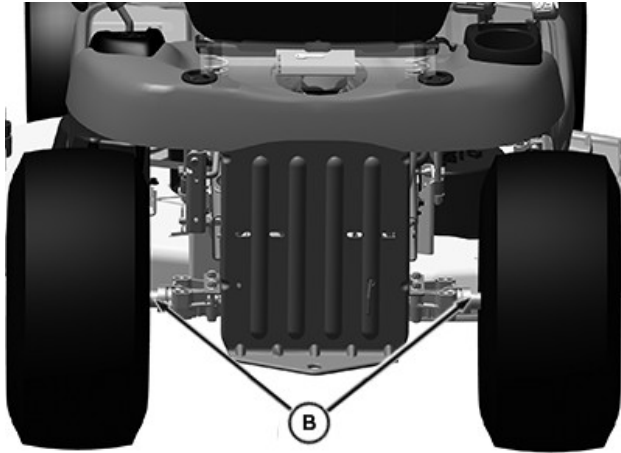

PY43279—UN—29MAY17

8. Secure rear of machine at both sides of the axle at points (B) to trailer with heavy-duty straps, chains, or cables. Straps must be directed down and outward from machine.
9. Secure hood to prevent from lifting while driving.

SR99263,00002ED-19-02JUL20

Transporting Material Collection System (If Equipped)

If the material collection system is left on the machine during transport, follow these guidelines when trailering the unit:

- Empty the cloth bags and remove them from the hopper. Full bags add extra weight which can overstress the hopper frame on rough roads. At road travel speeds, wind can cause premature wear of the cloth bags.
- Make sure that the hopper cover is latched securely to the hopper frame.
- If the unit is transported over long distances or at high speeds, remove the rear bagger or power flow chute before transport.

TH84124,000020A-19-10APR19

Using Weights

CAUTION: Avoid injury! The machine may become unstable when operating on slopes and/or with some attachments.

Use weights to improve stability when operating on slopes or using attachments.

Remove weights when not required.

IMPORTANT: Avoid damage! Never use liquid in tires or wheel weights as ballast. Transmission damage can occur.

When rear ballast is needed, use only the approved rear weight bracket and attaching weights.

NOTE: See your John Deere dealer or other service provider for recommended weights.

- Install front weights for added stability and steering control when you use equipment, such as the rear-mounted grass bagger.
- Install rear weights when using the snow blade or snowblower.
- Remove weights when not required.

MX00654,000039C-19-17OCT25

Using Tire Chains

IMPORTANT: Avoid damage! Do not use chains with mower deck.

Tire chains are recommended for use with most front attachments. Remove tire chains before installing mower deck.

See your attachment operator's manual for tire chain recommendation. See your John Deere dealer or other purchase provider.

SR99263,0000150-19-17OCT25

Using Accessories

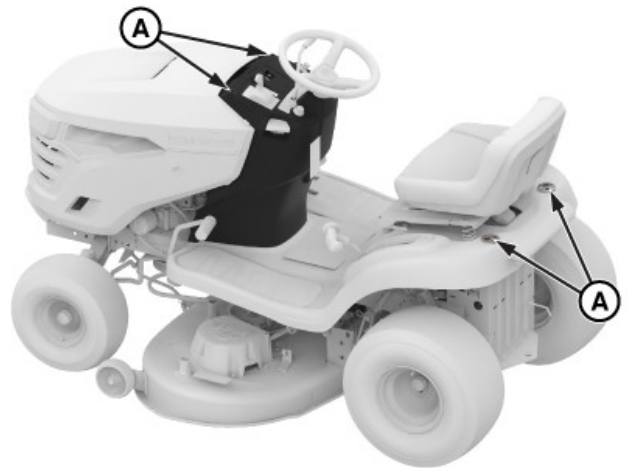

GX624364—UN—29MAY24

Using CargO Mount System

The front and rear CargO Mount system brackets (A) can be used for easy attachment of selected optional equipment.

Use John Deere approved optional equipment only. See

described in an attachment or pulling machine operator's manual.

- When towing over 150 kg (350 lb), depress forward travel pedal no more than halfway to avoid transmission damage. Always run tractor at full throttle when towing loads.
- Avoid inclines greater than a 10° slope while towing to avoid damage to the pulling machine. Use the Slope Guide located in this operator's manual to ensure proper machine towing operation. See SAFETY section, Operating on Slopes in this operator's manual for additional information.

IMPORTANT: Avoid damage! Always run tractor at full throttle when PTO is engaged and when towing loads.

RM87422.0000261-19-04AUG25

Service Intervals

Servicing Your Machine

IMPORTANT: Avoid damage!

Operating in extreme conditions may require more frequent service intervals:

- Engine components may become dirty or plugged when operating in extreme heat, dust or other severe conditions.
- Engine oil can degrade if machine is operated constantly at slow or low engine speeds or for frequent short periods of time.

High-pressure washing can cause damage to machine components. It is recommended that your vehicle be washed by hand or with a garden hose using mild soap.

Avoid spraying water with any great force near or into the following places:

- Air intake
- Electrical connections (including battery compartment)
- Wheel bearings
- Radiator (if equipped)
- Warning labels
- Other labels
- Ignition switch
- Instrument panel (gauges and switches)
- Breather/tube vents
- Mower spindles
- Mower idler bearings
- Transmission cooling fans

Please use the following timetables to perform routine maintenance on your machine.

Park the vehicle safely. (See Park Safely in the SAFETY Section.)

OUMX068,00006EF-19-22NOV16

Service Intervals

Initial Service 8 Hours

- Lubricate mower spindles.
- Check the mower deck spindle brakes (manual PTO).
- Lubricate front axle pivot and axle spindles.

Every 25 Hours

- Lubricate mower spindles.
- Lubricate front axle pivot and axle spindles.

Yearly or Every 50 Hours (Whichever Comes First)

- Replace engine oil and filter, or Easy Change™ 30-Second Oil Change System (if equipped).
- Replace air filter element(s).
- Replace fuel filter.
- Replace spark plug(s).
- Clean engine cooling fins.
- Clean or replace emission filter (if equipped).
- Sharpen or replace mower blades.
- Check or replace mower drive belts.
- Check and level mower deck.
- Clean mower deck.
- Check mower deck spindle brakes (manual PTO).
- Clean battery terminals.

Every 200 Hours

- Check and adjust valve clearance. (See your John Deere dealer or other service provider for this service.)

SDHTXN6,1746463748018-19-04JUN25

Service Lubrication

Grease

IMPORTANT: Avoid damage! Use recommended John Deere greases to avoid component failure and premature wear.

The following grease is recommended for service:

- John Deere Multi-Purpose HD Lithium Complex Grease
- Grease-Gard Premium Plus

Not all grease types are compatible; John Deere does not recommend mixing greases. If using any product other than the recommended grease in service, purge any remaining grease from the system before application. If not practical, grease twice as often until all old grease is purged from the system.

OUMX068,0000642-19-12APR24

Lubricating Front Axle

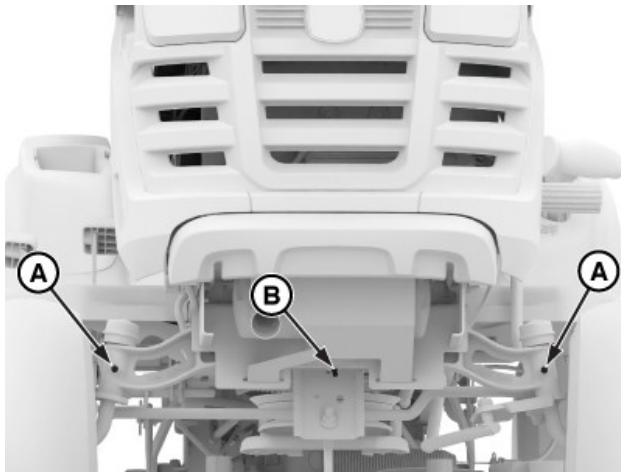

GX624365—UN—23MAY24

Wheel Spindles and Bushings

- Lubricate front wheel spindle grease fitting (A), with one or two shots of general all-purpose grease.

Front Axle Pivot

- Lubricate front axle center pivot grease fitting (B) with one or two shots of general all-purpose grease.

gvg6119,1716185004505-19-22MAY24

Lubricating Pivot Points

107 cm (42 in) Mower Deck:

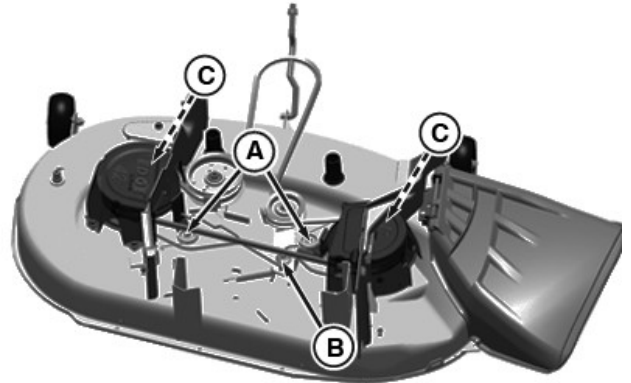

APY38196—UN—28JUL20

- A— Blade Brake Pivot (2)
- B— Deck Idler Pivot
- C— Spindle Grease Fitting (2)

- Lubricate the two spindle grease fittings (C) with one or two shots of general all-purpose grease.

122 cm (48 in) Mower Deck:

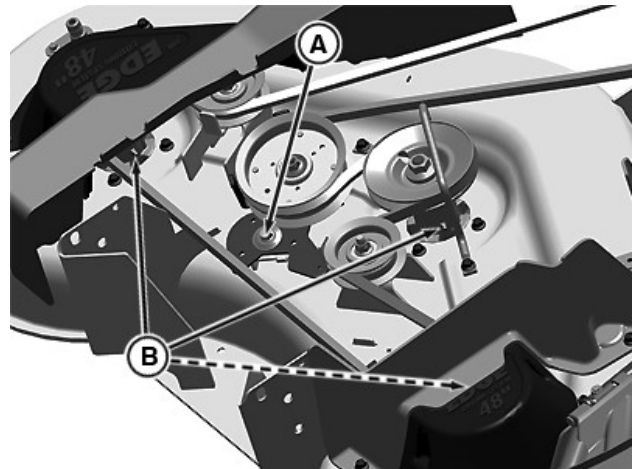

APY38197—UN—07JUL20

- A— Deck Idler Pivot
- B— Spindle Grease Fitting (3)

- Lubricate the deck idler pivot (A) with a general all-purpose spray lubricant.
- Lubricate the three spindle grease fittings (B) with one or two shots of general all-purpose grease.

BVVMSIT,00003A5-19-28JUL20

Service Engine

Emissions Service Information

Within the warranty period, John Deere will reimburse reasonable service costs incurred at service providers outside the John Deere authorized network only in an unsafe, emergency condition if an authorized John Deere dealer is not available and the failure does not arise from the owner's misuse or failure to perform required maintenance. An emergency situation exists under this section if, after 30 days, the authorized John Deere network is unable to perform the repairs or source replacement parts.

Emission Control System Certification Label

NOTE: Tampering with emission controls and components by unauthorized personnel may result in severe fines or penalties. Emission controls and components can only be adjusted by EPA and/or CARB authorized service centers. Contact your John Deere Retailer concerning emission controls and component questions.

The presence of an emissions label signifies that the engine has been certified with the United States Environmental Protection Agency (EPA) and/or California Air Resources Board (CARB).

The emissions warranty applies only to those engines marketed by John Deere that have been certified by the EPA and/or CARB; and used in the United States and Canada in off-road mobile equipment.

Altitude Adjustment (Gasoline or Propane Converted Engines Only)

If your engine features a carburetor it is calibrated by the engine manufacturer and is not adjustable.

If your engine is operated at altitudes below 610 m (2,000 ft.), a high altitude carburetor jet kit is not required. If your engine is operated at altitudes above 610 m (2,000 ft.), a high altitude carburetor jet kit may be required for proper engine performance and emissions control. Operating the engine with the wrong carburetor configuration at a given altitude may increase the engine's emissions and decrease fuel efficiency and performance.

See a qualified service provider for details on jet kit requirements for your specific product.

TC00531,00000EC-19-20FEB25

Avoid Fumes

CAUTION: Avoid injury! Engine exhaust fumes contain carbon monoxide and can cause serious illness or death.

Do not run an engine in an enclosed area, such as a garage, even with doors or windows opened.

Move the machine to an outside area before running the engine.

MP47322.00F4652-19-13JAN15

Gasoline Engine Oil

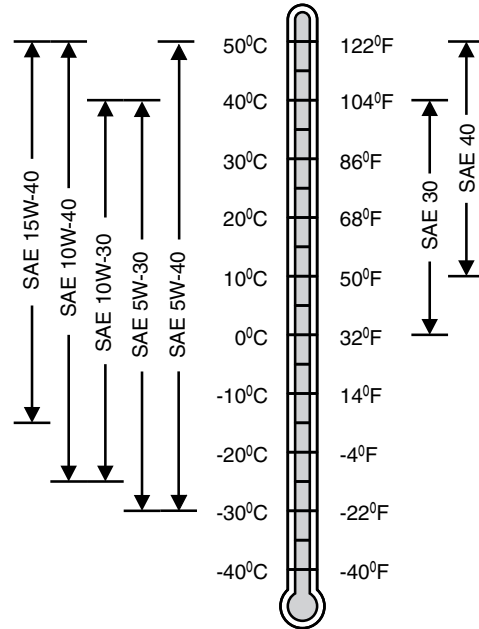

TS1744—UN—25AUG20

Oil Viscosities for Air Temperature Ranges

Use oil viscosity based on the expected air temperature range during the period between oil changes.

Using single viscosity grade oils such as SAE 30 or SAE 40 can reduce oil consumption in air cooled engines.

The following oils are approved:

- John Deere Plus-50™ II
- John Deere Turf-Gard™

Other oils may be used if they meet one or more of the following:

- ILSAC GF-6A
- API Service Category SP
- API Service Category SN
- API Service Category SM
- API Service Category SL
- API Service Category SJ
- ACEA Oil Sequence A3/B3
- ACEA Oil Sequence A3/B4
- ACEA Oil Sequence A5/B5
- ACEA Oil Sequence C5

Plus-50 is a trademark of Deere & Company
Turf-Gard is a trademark of Deere & Company

- ACEA Oil Sequence C4
- ACEA Oil Sequence C3
- ACEA Oil Sequence C2
- ACEA Oil Sequence C1

DX,ENOIL2-19-15JUL20

Checking Engine Oil Level

IMPORTANT: Avoid damage! Failure to check the oil level regularly could lead to serious engine problems if oil level is out of the operating range:

- Check oil level before operating.
- Check oil level when the engine is cold and not running.
- Keep oil level between the dipstick marks.
- Shut off engine before adding oil.

NOTE: Check oil twice a day if you run engine over 4 hours in a day.

Make sure engine is cold when checking engine oil level.

1. Park machine safely on level surface. (See Parking Safely in the Safety section.)
2. Lift hood.
3. Clean area around dipstick to prevent debris from falling into crankcase.

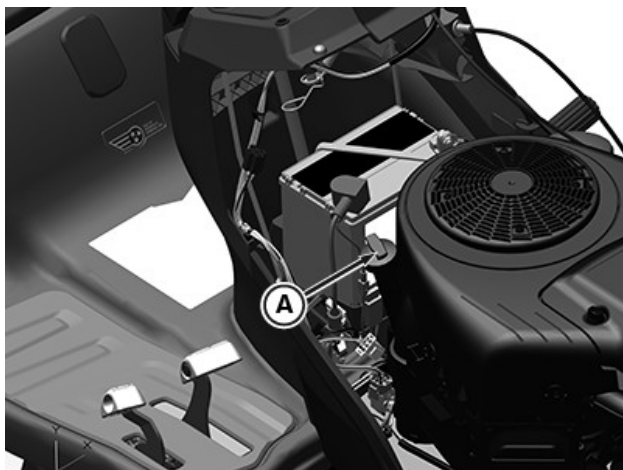

APY36165—UN—10JUL20

Twin Cylinder Engine Shown

4. Remove dipstick (A). Wipe with clean cloth.
5. Install and tighten dipstick.
6. Remove dipstick.
7. Check oil level on dipstick. Oil must be between ADD and FULL marks.

8. If oil level is low, add oil to bring oil level no higher than FULL mark on dipstick. Do not overfill.
9. Install and tighten dipstick. Lower hood.

MG39705.00004AD-19-15JUL20

Changing John Deere Easy Change™ 30-Second Oil Change System (If Equipped)

- For engines equipped with the Easy Change system.
- Replaces the filter and a portion of the engine oil.

⚠ CAUTION: Avoid Injury! Park the machine safely using park brake, turn off engine, and disconnect spark plug wires.

IMPORTANT: Avoid Damage! Oil should be changed when engine is cool. It is not necessary to run engine prior to changing oil.

1. Lift hood.
2. Remove shipping tie strap (if equipped) on first service only.



APY08908—UN—29MAY18

A— Easy Change Oil System (ECOS)

3. Remove old easy change oil system (ECOS) (A) by rotating the filter 90 degrees counterclockwise. Push down while rotating.
4. Wipe clean any drips.

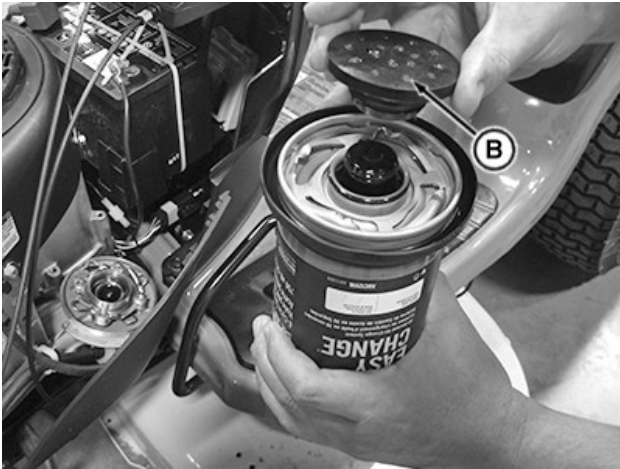

PY44545—UN—03AUG17

B— Rubber Cap

- Remove rubber cap (B) from new ECOS.



APY08907—UN—29MAY18

Shown in Locked Position

C— Alignment Pointer on the ECOS
 D— Unlocked Pointer
 E— Locked Pointer

- Install new ECOS by aligning the alignment pointer (C) on the ECOS with the unlocked pointer (D) on the engine. Rotate the ECOS 90 degrees clockwise, until the detent lock engages and the lock pointer on the ECOS (C) and engine (E) are aligned.

IMPORTANT: Avoid Damage! Keep turning the ECOS until the detent is engaged and the lock symbols are aligned.

- Check oil level with the dipstick. Add oil if necessary.
- Connect spark plug wires, start, and run engine at idle to check for leaks. Stop engine. Fix any leaks before operating.
- Lower the hood.
- The rubber cap can be installed on the used ECOS.

NOTE: Many local government recycling programs, authorized retailers, auto repair stations, and auto parts stores puncture and recycle used oil filters and oil.

SR99263,000014A-19-09JUL20

Changing Engine Oil and Filter on models not equipped with the John Deere Easy Change™ 30-Second Oil Change System

IMPORTANT: Avoid damage! Change the oil more often if the vehicle is used in extreme conditions:

- Extremely dusty conditions.
- Frequent slow or low-speed operation.
- Frequent short trips.

- Run engine to warm oil.
- Park machine safely. (See Parking Safely in the SAFETY section.)
- Lift hood.
- Remove closeout panels.

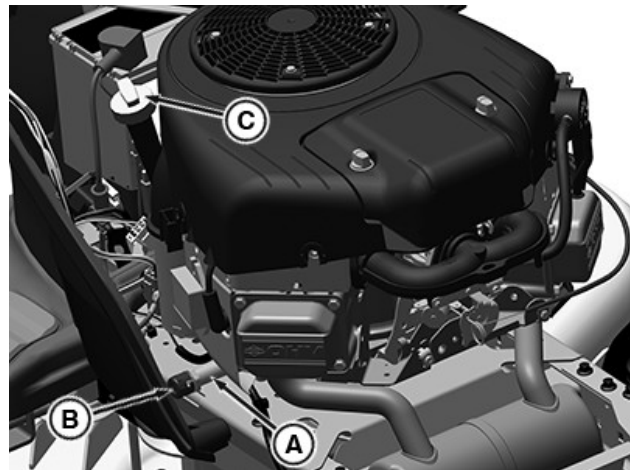

APY36166—UN—10JUL20

Twin Cylinder Engine is Shown.

- Put drain pan under drain valve (A).
- Rotate and remove drain cap (B) and drain oil into oil drain pan. Allow oil to drain completely.
- Remove dipstick (C).

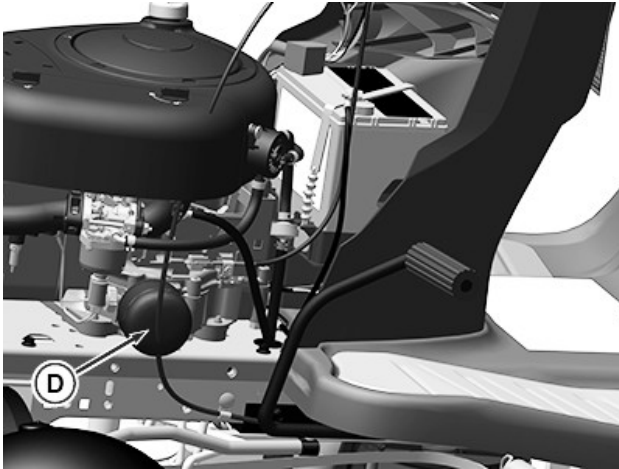

APY36168—UN—10JUL20

Single Cylinder Engine Shown

8. Replace oil filter (D).
 - a. Wipe dirt from around oil filter.
 - b. Place a drain pan or funnel under filter tray.
 - c. Remove old filter and filter gasket and dispose of properly. Wipe up any spilled oil.
 - d. Put a light coat of fresh, clean oil on the new filter gasket.
 - e. Install replacement oil filter by turning oil filter to the right (clockwise) until the rubber gasket contacts filter base. Tighten filter an additional one-half turn.
9. Install drain cap.

IMPORTANT: Avoid damage! Do not overfill. Overfilling can cause smoking, hard starting, fouling of spark plug, and oil saturation of air filter.

10. Add oil no higher than FULL mark on dipstick. Use approximately the amount of oil listed in the Specifications section. Do not overfill.
11. Install dipstick.
12. Connect spark plug wires to start and run engine at idle to check for leaks. Stop engine. Fix any leaks before operating.
13. Check oil level. Add oil if necessary.
14. Install closeout panels and lower hood.

NOTE: Many local government recycling programs, authorized retailers, auto repair stations, and auto parts stores will puncture and recycle used oil filters and oil.

MG39705,00004AE-19-24JUL20

Cleaning Air Intake Screen and Engine Fins

⚠ CAUTION: Avoid Injury! Compressed air can cause debris to fly a long distance.

- Clear work area of bystanders.
- Wear eye protection when using compressed air for cleaning purposes.
- Reduce compressed air pressure to 210 kPa (30 psi).

IMPORTANT: Avoid Damage! An obstructed air intake screen can cause engine damage due to overheating. Keep air intake screen and other external surfaces of the engine, including cooling fins, clean at all times to allow adequate air intake.

1. Park machine safely. (See Parking Safely in the Safety section.)
2. Lift hood.

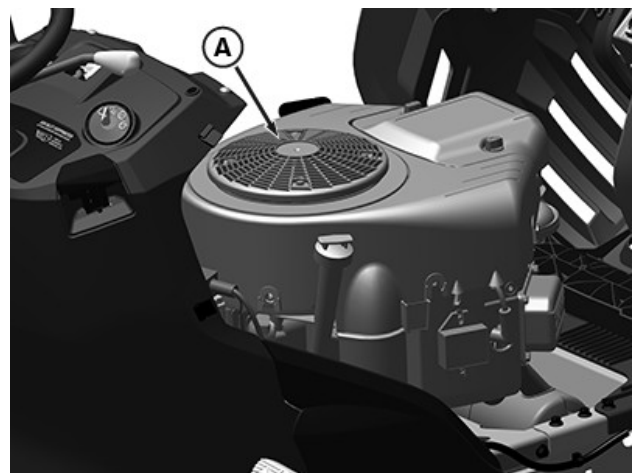

APY36167—UN—10JUL20

Twin cylinder engine shown

3. Clean air intake screen (A), cooling fins and external surfaces with rag, brush, vacuum or compressed air.
4. Lower hood.

OUC1023,00001C3-19-15JUL20

Checking and Cleaning Air Cleaner Elements

Checking and Cleaning Air Cleaner Elements (S100, S110, S120, S130, and S140)

1. Park the machine safely. (See "Parking Safely" in the SAFETY section.)
2. Let the engine cool.
3. Lift the hood.
4. Clean dirt and debris from the air cleaner cover.

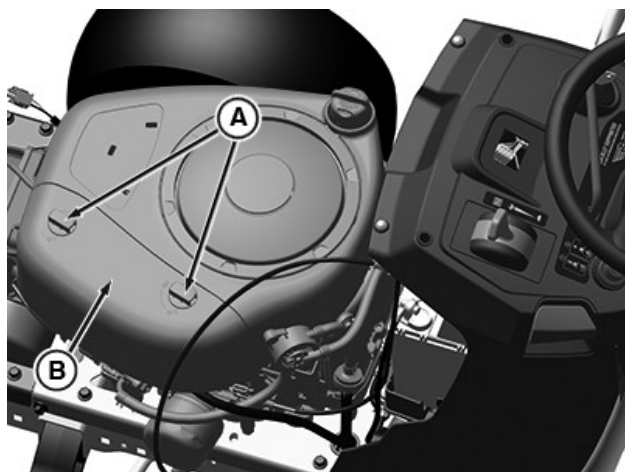

APY36169—UN—10JUL20

5. Lift the latch (A) to unlock the cover (B). Lift the cover forward and remove it.

IMPORTANT: Avoid Damage! Dirt and debris can enter the engine through a damaged filter element:

- Do not wash the paper element.
- Do not attempt to clean paper element by tapping it against another object.
- Do not use pressurized air to clean the element.
- Replace the element only if it is very dirty, damaged or if the seal is cracked.

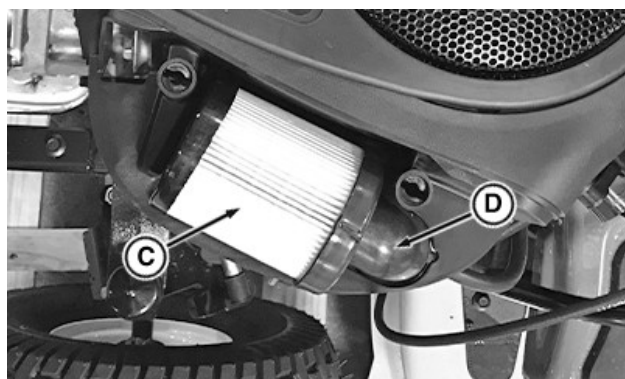

PY44553—UN—14AUG17

6. Inspect the paper filter element (C) without removing it. If the paper filter element is damaged or dirty, replace it with a new filter:

- Clean air cleaner base very carefully, preventing any dirt from falling into carburetor.
- Carefully pull the paper element from the air cleaner elbow (D).
- Install new paper filter element back onto air cleaner elbow.

7. Install the air cleaner cover and push the latch down to lock.

8. Lower the hood.

Checking and Cleaning Air Cleaner Elements (S160, S170, and S180)

1. Park the machine safely. (See "Parking Safely" in the SAFETY section.)
2. Let the engine cool.
3. Lift the hood.
4. Clean dirt and debris from the air cleaner cover.

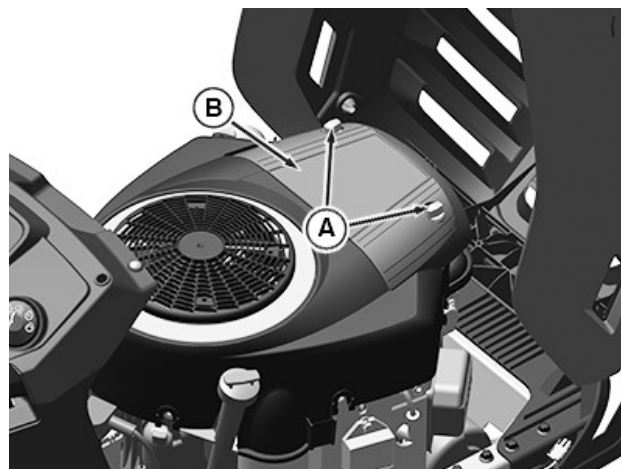

APY36171—UN—10JUL20

5. Loosen the two knobs (A) and remove the cover (B).

IMPORTANT: Avoid Damage! Dirt and debris can enter the engine through a damaged filter element:

- Do not wash the paper element.
- Do not attempt to clean the paper element by tapping it against another object.
- Do not use pressurized air to clean the element.
- Replace the element only if it is very dirty, damaged or if the seal is cracked.

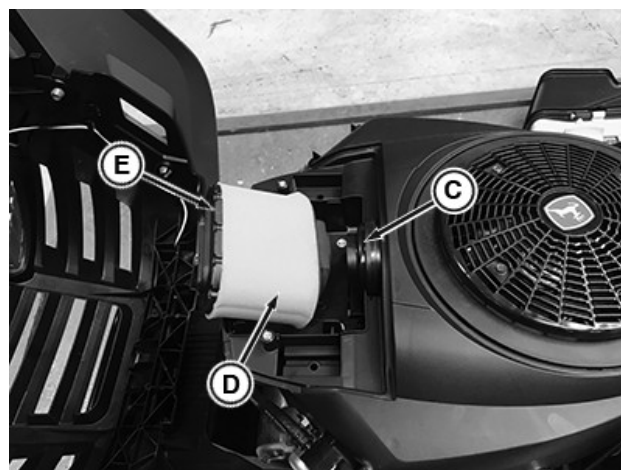

APY36198—UN—10JUL20

6. Pull filter assembly from air cleaner base (C). Inspect the foam pre-cleaner (D) without removing it. If the foam pre-cleaner is dirty:

- a. Remove it from the paper filter carefully.
 - b. Wash the precleaner in a solution of warm water and liquid detergent. Do not use oil.
 - c. Rinse the precleaner thoroughly. Squeeze out excess water with a dry cloth until the precleaner is completely dry.
7. Inspect the paper filter element (E). If the paper filter element is damaged or dirty, replace it with a new filter.
 8. Clean the air cleaner base very carefully, preventing any dirt from falling into the carburetor.
 9. Install the foam precleaner on the paper filter element.
 10. Install the new filter assembly back onto the air cleaner base.
 11. Install the air cleaner cover and tighten the two knobs.
 12. Lower the hood.

SDHTXN6,1745841602070-19-05MAY25

Checking Spark Plug

1. Park machine safely. (See Parking Safely in the SAFETY section.)
2. Let engine cool.
3. Lift hood.

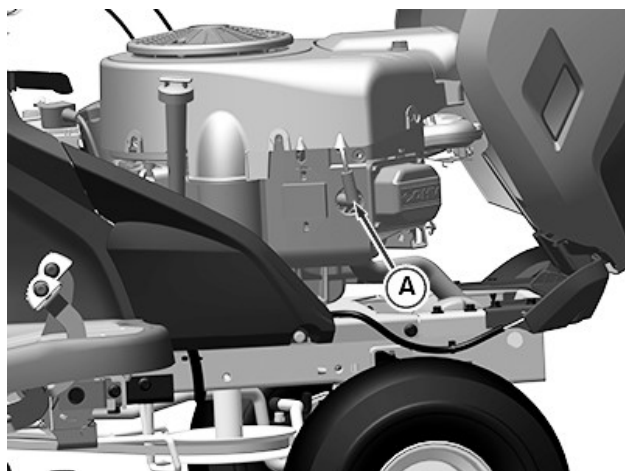

APY36172—UN—10JUL20

Twin cylinder engine shown

4. Disconnect spark plug wire(s) (A), one on each side on V-twin engines.
5. Remove spark plug(s).
6. Clean spark plug carefully with a wire brush.
7. Inspect spark plug for:
 - Cracked porcelain.

- Pitted or damaged electrodes.
- Other wear or damage.

8. Replace spark plug as necessary.

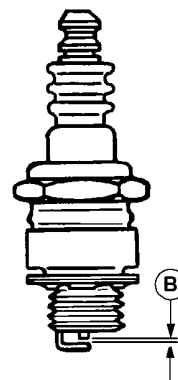

GXAL42022—UN—04MAR13

9. Check plug gap (B) with a wire feeler gauge. To change gap, move the outer electrode.

Gap must meet specifications.

Specification

Spark Plug—Gap 0.030 in. (0.76 mm)

10. Install and tighten spark plugs to specifications.

Specification

Spark Plug—Torque 15 lb-ft (20 N·m)

11. Connect spark plug wire(s) and lower hood.

MG39705.00004AF-19-02JUL20

Replacing Fuel Filter

CAUTION: Avoid injury! Fuel vapors are explosive and flammable:

- Do not smoke while handling fuel.
- Keep fuel away from flames or sparks.
- Shut off engine before servicing.
- Cool engine before servicing.
- Work in a well-ventilated area.
- Clean up spilled fuel immediately.

NOTE: Change filter when fuel is low.

1. Park machine safely. (See Parking Safely in the Safety section).
2. Lift hood.
3. Let engine cool.
4. Put a drain pan under the fuel filter.



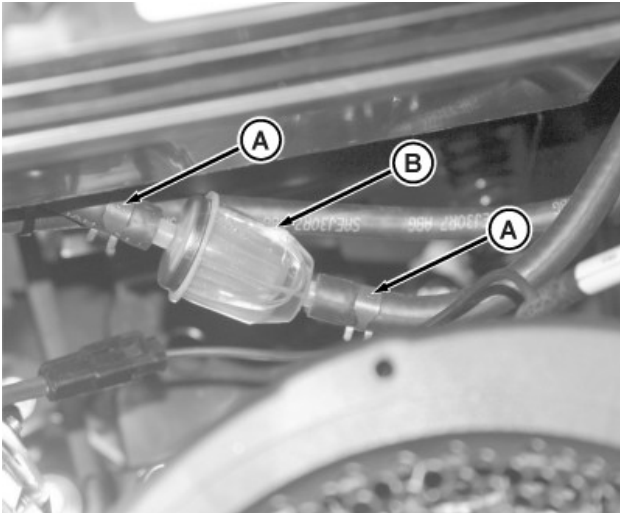

MXT015030—UN—02JUL15

5. Slide hose clamps (A) away from the fuel filter (B) using pliers.
6. Disconnect hoses from the filter.

IMPORTANT: Avoid damage! Incorrect installation of the fuel filter may cause engine damage. Install the filter with the arrow pointing in the direction of fuel flow (towards the engine) for proper operation.

7. Connect hoses to the new filter making sure that the filter arrow is pointing in the direction of the fuel flow.
8. Install clamps and check for leaks.
9. Lower hood.

MG39705,00004C2-19-02SEP20

Spark Arrestor Maintenance (If Equipped)

Spark arrestor assemblies include a screen element that should be inspected and cleaned periodically. Visually inspect the screen for tears, broken wires, or loose welds. Replace the spark arrestor assembly if any of these conditions exist. If the screen is determined to be in good condition, proceed with cleaning the screen by brushing away loose dirt or carbon using a brush.

RM87422,00002DA-19-05JUL17

Service Transmission

Checking Transmission

The transmission is a sealed component. No maintenance is required on this transmission. If you suspect any transmission problems, please contact your dealer or other service provider.

MP47322,00F465D-19-29JUL25

Service Mower

Removing or Installing Mower Drive Belt at Engine Drive Sheave in Manual PTO Machines

1. Park machine safely. (See Parking Safely in Safety section.)
2. Put lift lever in lowest position.

⚠ CAUTION: Avoid injury! Component is spring-assisted and under tension. Injury can occur if spring-assisted component is released suddenly.

NOTE: The sheave extension is only applicable for manual PTO models.

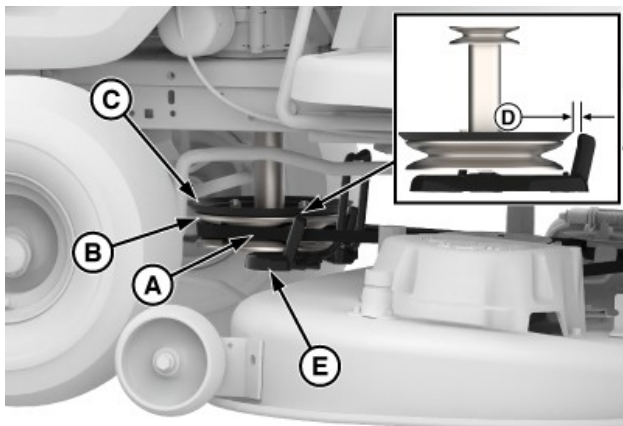

GX633065—UN—25JUN24

- A—Belt
- B—Drive Sheave
- C—Plastic Sheave Extension
- D—Gap
- E—Belt Keeper

3. Remove belt (A) from the drive sheave (B) through gap at (D) on both sides by flexing the plastic sheave extension (C). Do not pull down on belt keeper (E).
4. To install the belt (A) on the drive sheave (B), flex the plastic drive sheave extension (C) through the gap (D) on both sides between C and E without pulling down on (E).

gvg6119,1716185642208-19-28JUN24

Removing or Installing Mower Drive Belt at Engine Drive Sheave in Electronic PTO Machines

1. Park machine safely. (See Parking Safely in Safety section.)
2. Put wood blocks under each side of mower deck.
3. Put attachment lift lever in lowest position, bringing mower deck down onto blocks.

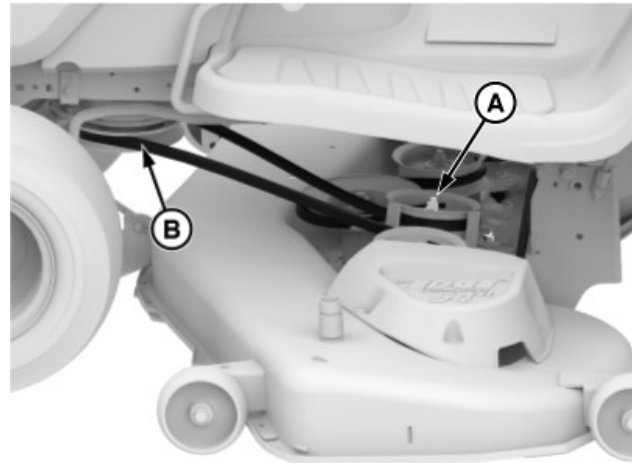

GX619005—UN—26JUN24

4. Put a 15 mm closed-end wrench or a socket on the idler sheave nut (A) and rotate clockwise to move idler sheave toward the front of the tractor and hold to release belt tension.
5. Remove mower drive belt from drive sheave (B).

⚠ CAUTION: Avoid injury! Mower lift arms can pinch fingers. Lift arms are spring loaded and can snap back when deck is removed.

Lock lift lever before pulling pin to remove mower deck.

6. Installation is the reverse of removal.

gvg6119,1719231253741-19-27JUN24

Removing Mower Deck

1. Park machine safely. (See Parking Safely in Safety section.)
2. Put wooden blocks under each side of the mower deck.
3. Put attachment lift lever in lowest position, bringing mower deck down onto blocks.
4. Remove the drive belt. (See Removing or Installing Mower Drive Belt at Engine Drive Sheave in Manual PTO Machines or Removing or Installing Mower Drive Belt at Engine Drive Sheave in Electronic PTO Machines in the Service Mower section.)

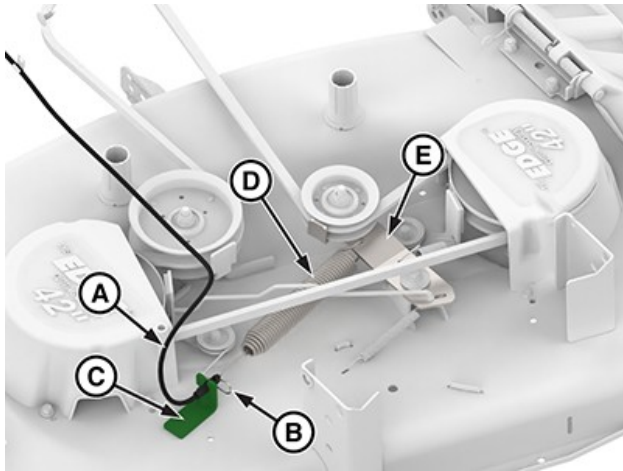

GX624367—UN—30MAY24

NOTE: The removal of the engagement drive cable is only for Manual PTO machines

On machines with manual PTO mower deck, disconnect mower engagement drive cable (A) on the left side of the mower deck.

- a. Remove spring locking pin (B), lift up and remove from bracket (C).
- b. Push down on center of spring (D) and pull the hook out of bracket (E).

CAUTION: Avoid injury! Mower lift arms can pinch fingers. Lift arms are spring loaded and can snap back when deck is removed.

Lock lift lever before pulling pin to remove mower deck.

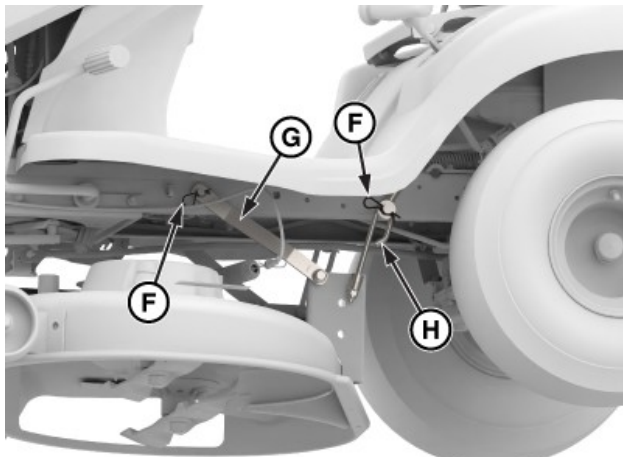

GX624362—UN—05JUN24

6. Remove spring locking pins (F), washers, pull rear draft arm (G) and adjustable lift links (H) off of the pins on each side of machine.

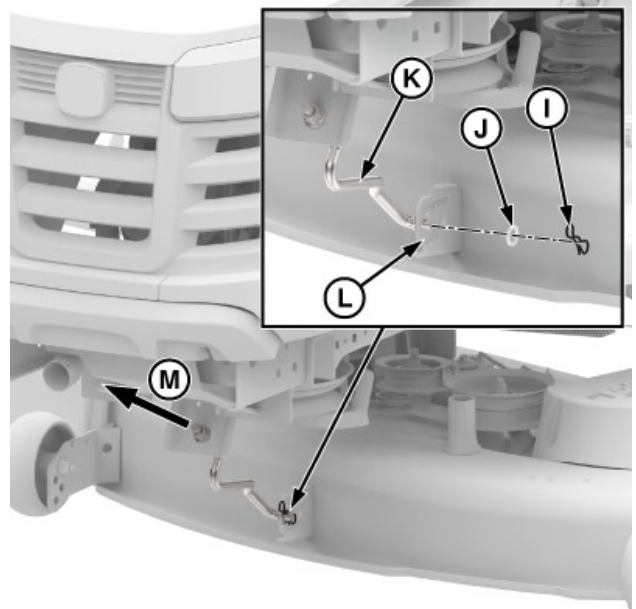

GX633061—UN—01JUL24

7. Remove spring locking pin (I), washer (J), and front draft rod (K) from the mower deck bracket (L).
8. Remove wooden blocks from both sides and slide mower deck out from under the machine.
9. To operate the machine without the mower deck see below step:
 - To remove from the machine: Pull front draft rod (K) out from front of the unit in direction (M) without removing nut.

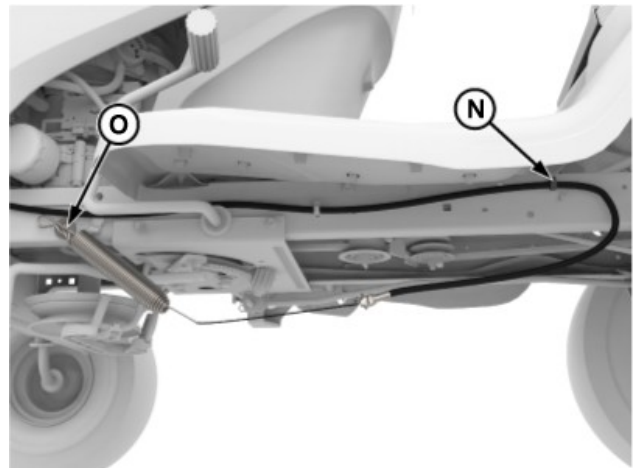

GX624344—UN—26JUN24

- On manual PTO mower deck only: Push mower engagement drive cable into clip (N) and hook end of the cable spring with hardware (O) into peg on the left side of machine frame.

Installing Mower Deck

1. Park machine safely. (See Parking Safely in Safety section.)
2. Put attachment lift lever in the transport position.
3. Slide mower under machine.
4. Put wooden blocks under each side of mower deck.
5. Put attachment lift lever in lowest position.

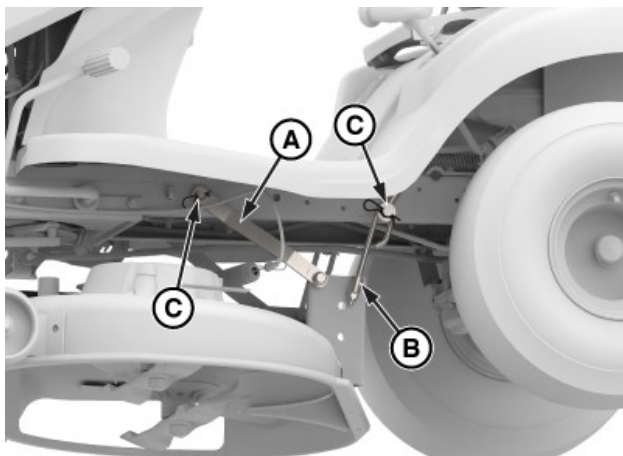

GX624369—UN—23MAY24

6. Fasten rear draft arm (A) and adjustable lift link (B) on each side with washers and spring locking pins (C).

IMPORTANT: Avoid damage! To prevent clutch damage, make sure that front draft rod is installed correctly. Secure rod with washer and spring locking pin on the left side of mower deck bracket.

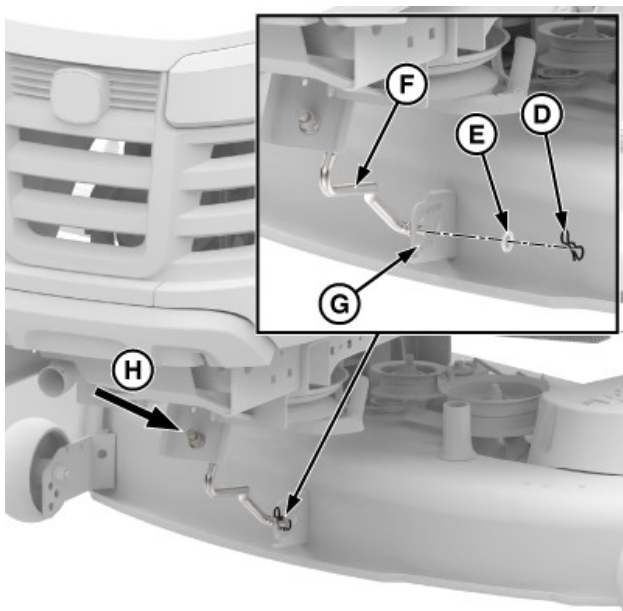

GX633062—UN—01JUL24

7. Install front draft rod (F) into the front rod hanger

bracket in direction (H) and then into the mower deck bracket (G) in the upper hole, without removing the nut on the front draft rod.

8. Secure front draft rod with washer (E) and spring locking pin (D).
9. Install the drive belt. (See Removing or Installing Mower Drive Belt at Engine Drive Sheave in Manual PTO Machines or Removing or Installing Mower Drive Belt at Engine Drive Sheave in Electronic PTO Machines in the Service Mower section.)

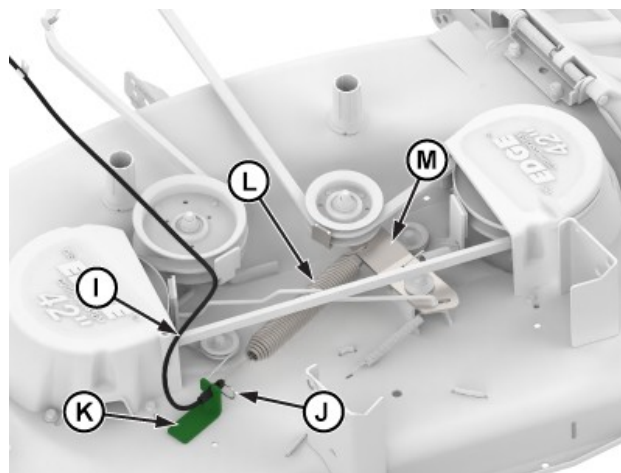

GX619013—UN—01JUL24

10. On manual PTO mower deck only: Connect mower engagement drive cable (I) on the left side of the mower deck.
 - a. Ensure that the spring cable is routed under the belt.
 - b. Install spring locking pin (J), lift down, and install into bracket (K).
 - c. Push on center of spring (L) and install into the idler sheave bracket (M).
11. Lift mower deck to transport position and then remove wood blocks from both sides of mower deck.
12. Level mower deck. (See Checking and Adjusting Mower Deck Level in the Operating section.)

gvg6119,1716185698820-19-01JUL24

Replacing Mower Drive Belt—42 in Deck

1. Park machine safely. (See Parking Safely in the Safety section.)
2. Remove mower deck. (See Removing Mower Deck in the Service Mower section.)

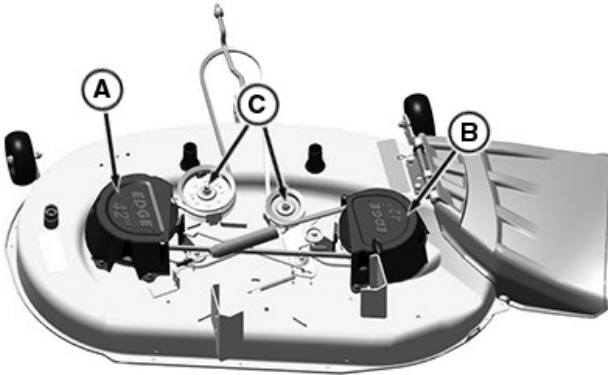

APY22313—UN—18JUL19

3. Remove drive belt:
 - a. Remove three capscrews and belt shield (A).
 - b. Remove two capscrews and belt shield (B).
 - c. Loosen sheaves (C).
 - d. Remove mower belt.
4. Inspect belt for wear or damage; replace as necessary.
5. Clean top surface of mower deck and sheaves.
6. Install belt on mower deck as shown. Make sure belt is in the groove of each sheave.
7. Tighten sheaves to specifications.

Specification

Mower Deck Drive Sheave Nuts
(42 in Mower Deck)—Torque. 47 N·m (35 lb-ft)

8. Install belt shields.
9. Install mower deck.

gvg6119,1717493094281-19-01JUL24

Replacing Mower Drive Belt—48 in and 54 in Decks

1. Park machine safely. (See Parking Safely in Safety section.)
2. Remove mower deck. (See Removing Mower Deck in the Service Mower section.)

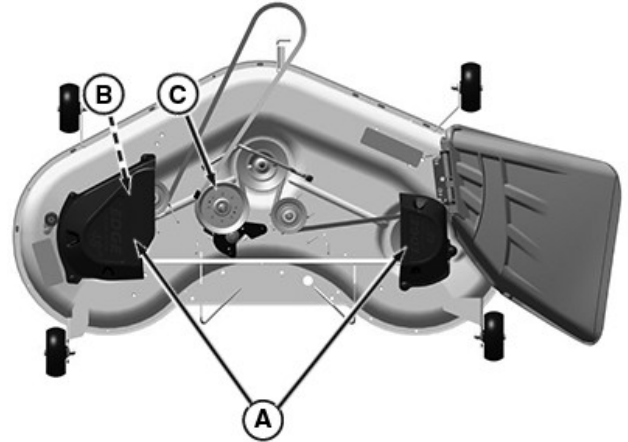

APY22314—UN—24JUL19

- Remove five capscrews and left and right belt shields (A).
3. Remove drive belt.
 - a. Loosen left side sheaves (B) and (C).
 - b. Remove mower belt.
4. Inspect belt for wear or damage; replace as necessary.
5. Clean top surface of mower deck and sheaves.
6. Install belt on mower deck as shown. Make sure belt is in the groove of each sheave.
7. Tighten sheaves to specifications.

Specification

Mower Deck Drive Sheave Nuts
(48 in and 54 in Mower Deck)—Torque. 47 N·m (35 lb-ft)

8. Install belt shields.
9. Install mower deck.

gvg6119,1717493128049-19-01JUL24

Checking for Bent Mower Blades

⚠ CAUTION: Avoid Injury! Blades are sharp. Always wear gloves when handling blades or working near blades.
Replace blades if defective. Never straighten or weld them.

1. Park machine safely. (See Parking Safely in the Safety section.)
2. Raise mower deck to highest position to access blades.



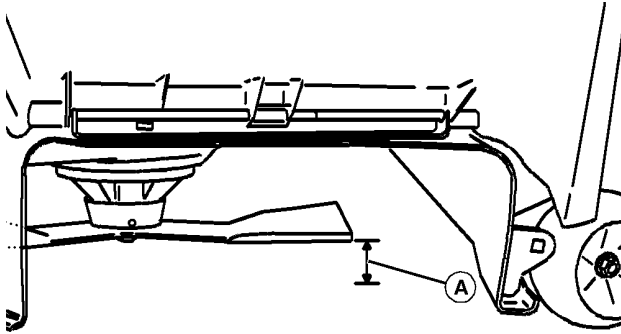

MXAL42867—UN—09APR13

Mower Deck With Side Discharge Used for Illustration

3. Measure distance (A) between blade tip and flat ground surface.
4. Rotate blade 180° and measure distance between other blade tip and flat ground surface.
5. Install new blade if the difference between the two measurements is more than 3 mm (1/8 in).
6. Repeat for all blades.

SR99263,00002AA-19-10APR20

Servicing Mower Blades

⚠ CAUTION: Avoid injury! Rotating blades are dangerous. Before adjusting or servicing mower:

Disconnect spark plug wires or battery negative (-) cable to prevent engine from starting accidentally.

Always wear gloves when handling mower blades or working near blades.

Removing Mower Blades

1. Park machine safely. (See Parking Safely in Safety section.)
2. Raise mower deck to gain access to mower blades. If necessary, remove mower deck.
3. Block mower blade with a piece of wood to prevent it from spinning.

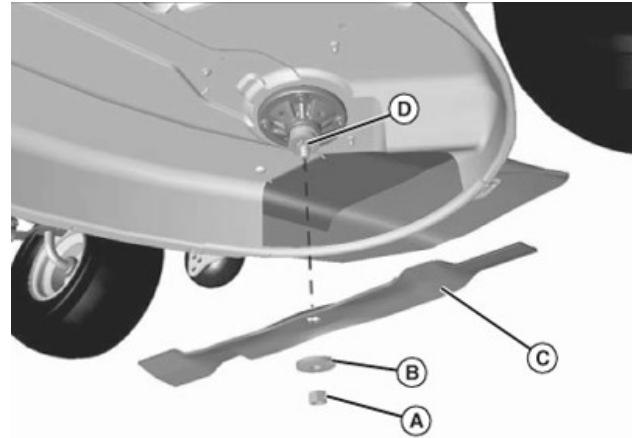

GXAL42597—UN—19MAR13

4. Loosen and remove nut (A), washer (B), and blade (C).
5. Inspect blades; sharpen, balance, or replace blades as necessary.

Installing Mower Blades

1. Position mower blade (C) with the cutting edge towards the ground.
2. Align the splined center hole in the blade with the splined spindle shaft (D) and put the blade onto the mower spindle shaft.
3. Install washer, with cupped side towards blade, and install nut to secure blade onto splined spindle shaft.
4. Block mower blade with a piece of wood to prevent spinning and tighten nut.
5. Using 15/16 in socket, tighten 5/8 in blade nut to specifications.

Specification

Mower Deck Blade Nut—Torque 88 N·m (65 lb·ft)

SR99263,00002E3-19-06APR20

Sharpen Blades

⚠ CAUTION: Avoid injury! Blades are sharp. Always wear gloves when handling blades or working near blades.

Always wear safety eye protection when grinding.

- Sharpen blades with grinder, hand file, or electric blade sharpener.



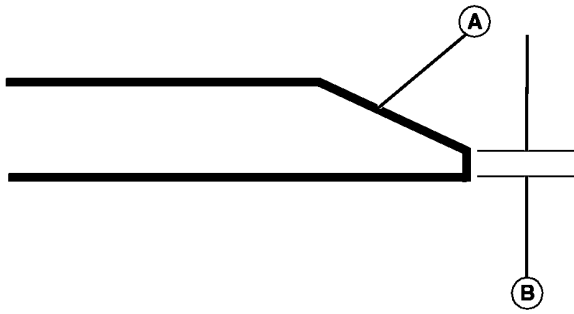

GXAL42041—UN—04MAR13

- Keep original bevel (A) when grinding.
- The blade cutting edge (B) should meet specifications.

Specification

Mower Blade Cutting
Edge—Distance..... 0.40 mm
(1/64 in)

- Balance blades before installing.

MX00654,000039E-19-17AUG23

Balance Blades

⚠ CAUTION: Avoid injury! Blades are sharp. Always wear gloves when handling blades or working near blades.

1. Clean blade.

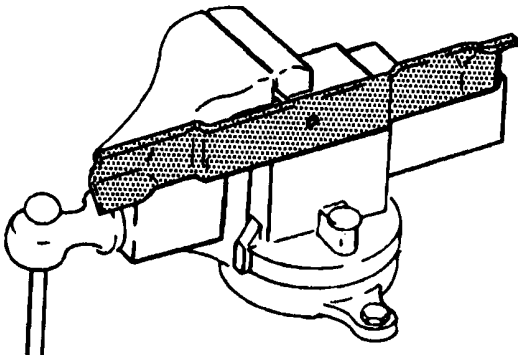

GXAL42042—UN—04MAR13

2. Put blade on nail in a vise. Turn blade to horizontal position.
3. Check balance. If blade is not balanced, heavy end of blade will drop.
4. Grind bevel of heavy end. Do not change blade bevel.

MX00654,000039F-19-17AUG23



Service Electrical

Electrical

WARNING: Avoid injury! Battery posts, terminals and related accessories contain lead and lead components, chemicals known to the State of California to cause cancer and reproductive harm. **Wash hands after handling.**

MP47322,00F466E-19-04AUG25

Service the Battery Safely



MXAL42869—UN—09APR13

CAUTION: Avoid injury! The battery produces a flammable and explosive gas.

To prevent the battery from exploding:

- Do not smoke or have open flame near battery.
- Wear eye protection and gloves.
- Do not allow direct metal contact across battery posts.
- Remove negative cable first when disconnecting.
- Install negative cable last when connecting.

MP47322,00F466F-19-13JAN15

Removing and Installing the Battery

Removing

1. Park machine safely and lift hood. (See Parking Safely in the Safety Section.)

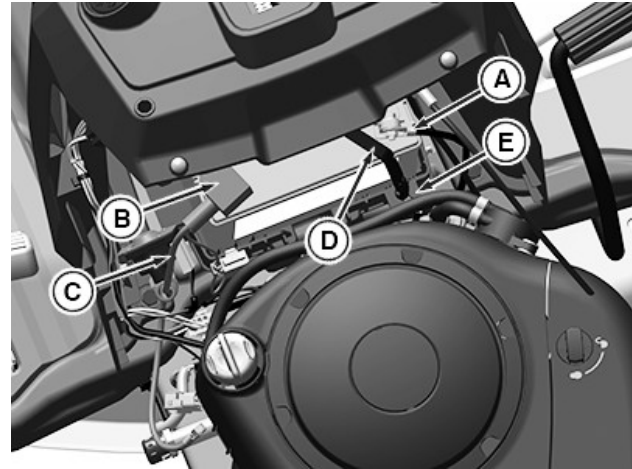

APY36177—UN—10JUL20

2. Disconnect negative (-) battery cable (A).
3. Push red cover (B) away from positive (+) battery terminal and remove cable (C) from battery.
4. Remove the battery strap (D) from C type clip (E) on the front left side of the battery tray.
5. Remove battery.

Installing

1. Place battery into battery tray.

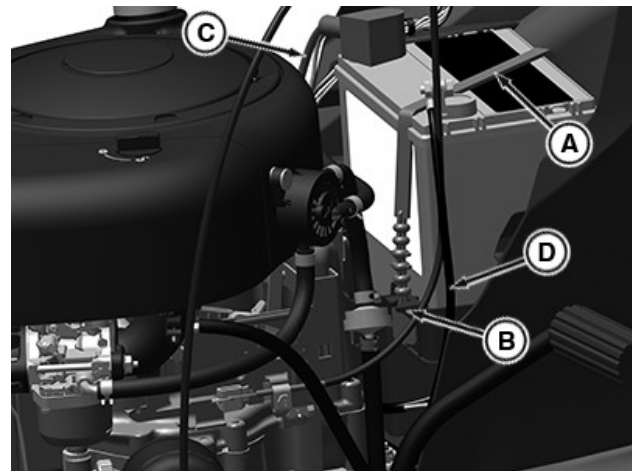

APY36178—UN—27JUL20

2. Insert the battery strap (A) into the clip (B) between the beads on the strap.
3. Connect positive (+) cable (C) to positive (+) battery terminal first, then negative (-) cable (D) to negative (-) battery terminal.
4. Apply spray lubricant to terminal to help prevent corrosion.
5. Slide red cover over positive battery terminal.

MG39705,00004B3-19-03JUL20

Clean Battery and Terminals

1. Park machine safely. (See Parking Safely in the Safety section.)
2. Disconnect and remove battery.
3. Wash battery with solution of four tablespoons of baking soda to one gallon of water. Be careful not to get the soda solution into the cells.
4. Rinse the battery with plain water and dry.
5. Clean terminals and battery cable ends with wire brush until bright.
6. Install battery.
7. Attach cables to battery terminals, beginning with the positive cable, using washers and nuts.
8. Apply spray lubricant to terminal to prevent corrosion.

MP47322.00F4671-19-17AUG23

Use Booster Battery

⚠ CAUTION: Avoid injury! The battery produces a flammable and explosive gas.

To prevent the battery from exploding:

- Do not smoke or have open flame near battery.
 - Wear eye protection and gloves.
 - Do not jump-start or charge a frozen battery.
- Warm battery to:**

Specification

Battery—Temperature. 16°C (60°F)

- Do not connect the negative (-) booster cable to the negative (-) terminal of the discharged battery. Connect at a good ground location away from the discharged battery.

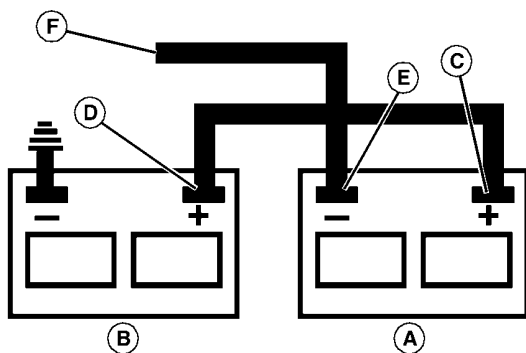

MXAL42872—UN—09APR13

A—Booster Battery
 B—Disabled Vehicle Battery
 C—Positive (+) Post
 D—Positive (+) Post
 E—Negative (-) Post
 F—Negative (-) Booster Cable End

F—Negative (-) Booster Cable End

1. Connect positive (+) booster cable to booster battery (A) positive (+) post (C).
2. Connect the other end of positive (+) booster cable to the disabled vehicle battery (B) positive (+) post (D).
3. Connect negative (-) booster cable to booster battery negative (-) post (E).

IMPORTANT: Avoid damage! Electric charges from the booster battery damages machine components. Do not install negative booster cable to machine frame. Install only to the engine block.

Install negative booster cable away from moving parts in the engine compartment, such as belts and fan blades.

4. Connect the other end (F) of negative (-) booster cable to a metal part of the disabled machine engine block away from battery.
5. Start the engine of the disabled machine and run machine for several minutes.
6. Carefully disconnect the booster cables in the exact reverse order: negative cable first and then the positive cable.

MP47322.00F4672-19-10AUG23

Replacing Headlight

1. Park the machine safely. (See "Parking Safely" in the Safety section.)
2. Lift the hood.

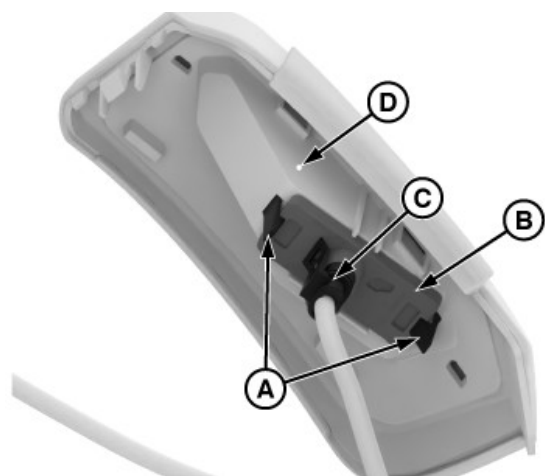

MX663343—UN—06MAY25

3. Spread the tabs (A).
4. Remove the LED light (B) from the headlight assembly (D).
5. Disconnect the connector (C) from the LED light (B).



6. Connect the new LED light to the connector.
7. Install the new LED light into headlight assembly (D).
8. Lower the hood.

SDHTXN6,1745842272398-19-06MAY25

Replacing Fuse

1. Park machine safely. (See Parking Safely in the Safety section.)
2. Lift hood.

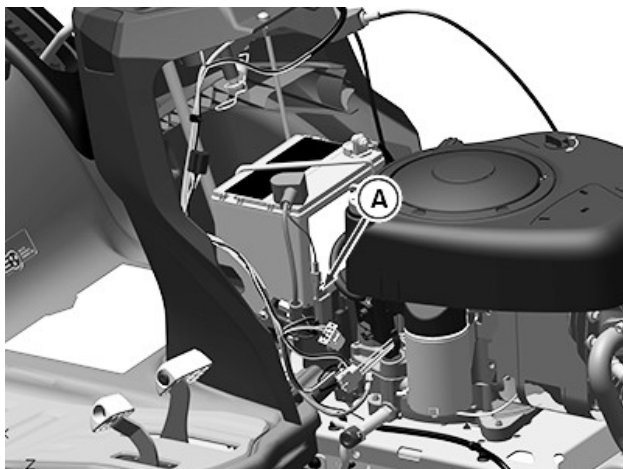

APY36188—UN—10JUL20

3. Pull defective fuse (A) out of socket.
4. Check metal clip in fuse window and discard fuse if clip is broken.
5. Push new 20 A fuse into socket.
6. Lower hood.

MG39705,00004B5-19-03JUL20

Service Miscellaneous

Gasoline Fuel for 4-Cycle Engines

Use unleaded gasoline with a minimum octane rating of 87 AKI (anti-knock index) or 90 RON (research octane number). Gasoline fuels specified to EN 228 or ASTM D4814 are recommended.

Fuel blends of unleaded gasoline with a maximum 10% ethanol or 15% MTBE (methyl tertiary-butyl ether) are also acceptable.

CAUTION: Reduce the risk of fire. Handle fuel carefully. **DO NOT** fill the fuel tank when the engine is running or hot. Stop engine and allow it to cool for several minutes before filling fuel tank. Fill fuel tank only to the bottom of the filler neck.

Refuel outdoors. **DO NOT** smoke while you fill the fuel tank or service the fuel system.

Store fuel in properly identified polyethylene containers.

When storing fuel, add John Deere Gasoline Conditioner and Stabilizer (or equivalent) at the specified concentration.

IMPORTANT: **DO NOT** use methanol or fuel blends that contain methanol.

Avoid spilling fuel. Gasoline can damage plastic and painted surfaces.

DO NOT mix oil with gasoline.

DX,FUEL2-19-15MAY13

Fill Fuel Tank

CAUTION: Avoid injury! Fuel vapors are explosive and flammable:

- Shut engine off before filling fuel tank.
- Allow engine to cool before refueling.
- Do not smoke while handling fuel.
- Keep fuel away from flames or sparks.
- Fill fuel tank outdoors or in ventilated area.
- Clean up spilled fuel immediately.
- Prevent static electric discharge by using a clean, approved, non metal container.

IMPORTANT: Avoid damage! Dirt and water in fuel causes engine damage:

- Clean dirt and debris from the fuel tank opening.
- Use clean, fresh, stabilized fuel.
- Fill the fuel tank at the end of operation each day to prevent condensation and freezing during cold weather.

- If using a funnel, make sure it is plastic and has no screen or filter.

1. Park machine safely. (See Parking Safely in the Safety section.)
2. Allow engine to cool.
3. Remove any debris from area around fuel tank cap.
4. Remove fuel tank cap slowly to allow any pressure built up in tank to escape.
5. Fill fuel tank only to bottom of filler neck. Do not overfill.

NOTE: On some models, the fuel tank cap will click when it is tight.

6. Install fuel tank cap and turn cap until it is tight.

MP47322,00F4675-19-10AUG23

Lifting Machine

1. Park machine safely. (See Parking Safely in the Safety section.)

CAUTION: Avoid injury! The machine can fall or slip from an unsafe lifting device or supports.

- Use a safe lifting device rated for the load to be lifted.
- Lower machine onto jackstands or other stable supports and block wheels before servicing.

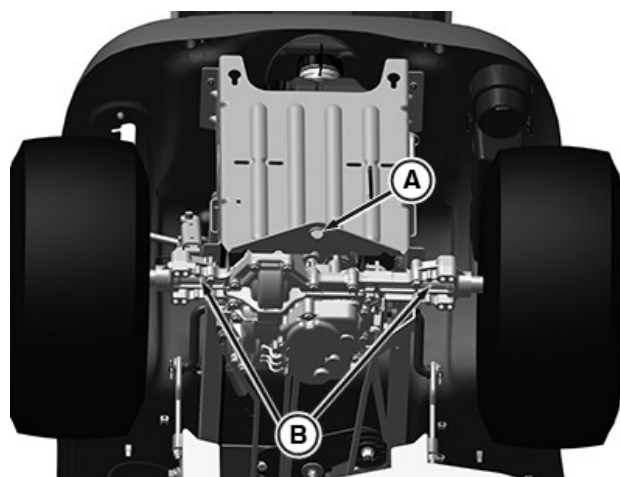

APY36180—UN—10JUL20

2. Safely lift rear of the machine at the machine frame point (A). Place jackstands or other stable supports onto transaxle locations (B) where mounting bolts for frame come through.
3. If only lifting rear of machine, block front wheels remaining on ground to avoid movement of the machine.

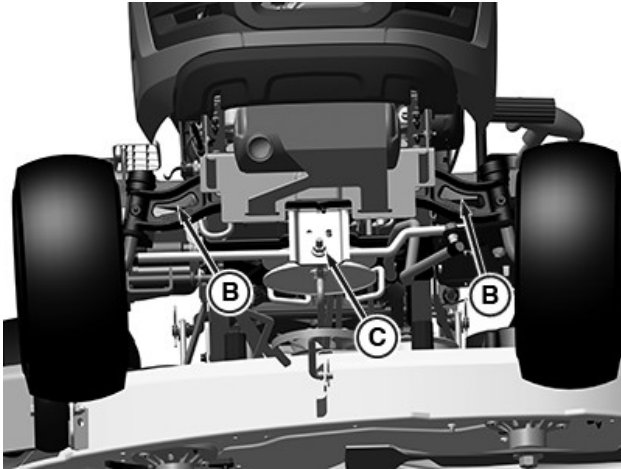

APY36181—UN—10JUL20

4. Safely lift front of the machine at the machine frame point (C). Place jackstands or other stable supports under the frame on each side at location (B).
5. If only lifting front of machine, block rear wheels remaining on ground to avoid movement of the machine.
6. To lower the machine, lift front and/or rear of machine, and remove jackstands or supports. Lower machine.

MG39705.00004ED-19-28JUL20

4. Add or remove air to meet specified tire pressure. (See Specifications section for recommended tire pressures.)

MP47322.00F4677-19-10JUN20

Removing and Installing Hood

Removing

⚠ CAUTION: Avoid injury! Touching hot surfaces can burn skin. The engine, components, and fluids are hot if the engine has been running. Allow the engine to cool before servicing or working near the engine and components.

IMPORTANT: Avoid damage! Do not operate machine with hood open. Hood must be closed for proper engine cooling and exhaust.

1. Park machine safely. (See Parking Safely in the Safety section.)
2. Let engine cool.

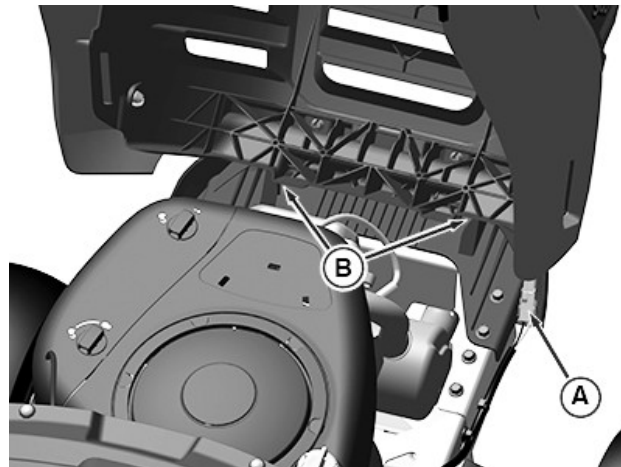

APY36182—UN—10JUL20

Checking Tire Pressure

⚠ CAUTION: Avoid injury! Explosive separation of tire and rim parts is possible when they are serviced incorrectly:

- Do not attempt to mount a tire without the proper equipment and experience to perform the job.
- Make sure that all tires are inflated to the recommended pressure, especially when operating on slopes. Low pressure can cause machine to become unstable on slopes.
- Do not weld or heat a wheel and tire assembly. Heat can cause an increase in air pressure resulting in an explosion. Welding can structurally weaken or deform the wheel.
- Do not stand in front or over the tire assembly when inflating. Use a clip-on chuck and extension hose long enough to allow you to stand to one side.

1. Check tires for damage.
2. Check tire pressure with an accurate low-pressure gauge.
3. A lower pressure will improve traction and performance depending on turf conditions or if transport areas have steep inclines.

3. Open hood.
4. Disconnect wiring harness (A).

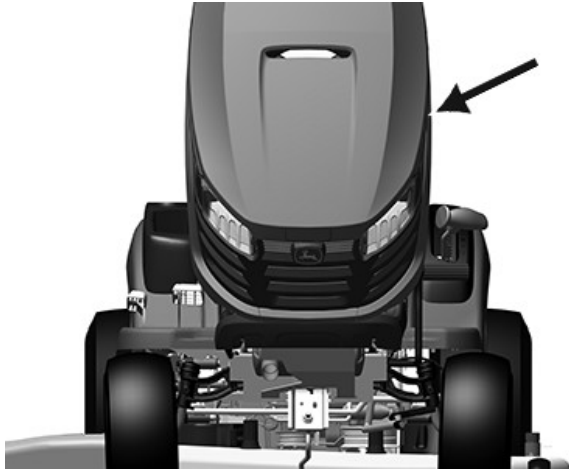

APY36183—UN—10JUL20

5. Apply pressure to the pointed position on the left side of hood and slowly lower hood. Left side pivot will release after rotating closed approximately 45°. Once left side pivot releases, slide out right side pivot. Lower hood slightly and lift hood from brackets (B).

Installing

1. Slide right side hood pivot into the tractor bracket with hood in open position (left side pivot slides into place as hood closes) and slowly close hood.
2. Open hood.
3. Connect wiring harness. Verify that wiring harness is properly retained.
4. Close hood.

MG39705.00004EF-19-28JUL20

Cleaning Plastic Surfaces

IMPORTANT: Avoid damage! Improper care of machine plastic surfaces can damage that surface:

- Do not wipe plastic surfaces when they are dry. Dry wiping results in minor surface scratches.
- Use a soft, clean cloth (bath towel, diaper, automotive mitt.)
- Do not use abrasive materials, such as polishing compounds, on plastic surfaces.

1. Rinse hood and entire machine with clean water to remove dirt and dust that may scratch the surface.
2. Wash surface with clean water and a mild liquid automotive washing soap.

IMPORTANT: Avoid damage! Insect repellent spray may damage plastic and painted surfaces. Do not spray insect repellent near machine.

3. Dry thoroughly to avoid water spots.
4. Wax the surface with a liquid automotive wax. Use products that specifically say “contains no abrasives.”

IMPORTANT: Avoid damage! Do not use a power buffer to remove wax.

5. Buff applied wax by hand using a clean, soft cloth.

SR99263.00002B3-19-06APR20

Cleaning and Repairing Metal Surfaces

Cleaning:

Follow automotive practices to care for your vehicle's painted metal surfaces. Use a high-quality automotive wax regularly to maintain the factory look of your vehicle's painted surfaces.

Repairing Minor Scratches (surface scratch):

1. Clean area to be repaired thoroughly.

IMPORTANT: Avoid damage! Do not use rubbing compound on painted surfaces.

2. Use automotive polishing compound to remove surface scratches.
3. Apply wax to entire surface.

Repairing Deep Scratches (bare metal or primer showing):

1. Clean area to be repaired with rubbing alcohol or mineral spirits.
2. Use paint stick with factory-matched colors available from your service provider to fill scratches. Follow directions included on paint stick for use and for drying.
3. Smooth out surface using an automotive polishing compound. Do not use power buffer.
4. Apply wax to surface.

MP47322.00F467A-19-16JUL25

Avoid Damage to Plastic and Painted Surfaces

- Do not wipe plastic parts until they are rinsed first. Using a dry cloth causes scratches.
- Insect repellent spray damages plastic and painted surfaces. Do not spray insect repellent near machine.
- Be careful not to spill fuel on the machine. Fuel damages surfaces. Wipe up spilled fuel immediately.

MP47322.00F4630-19-02DEC22

Removing and Installing Front Wheel Assembly

Removing:

1. Park machine safely. (See Parking Safely in the Safety section.)

⚠ CAUTION: Avoid injury! The machine can fall or slip from an unsafe lifting device or supports.

- Use a safe lifting device rated for the load to be lifted.
- Lower machine onto jackstands or other stable supports and block wheels before servicing.

IMPORTANT: Avoid damage! Place jackstands under frame, not under transmission or engine, when raising or supporting machine.

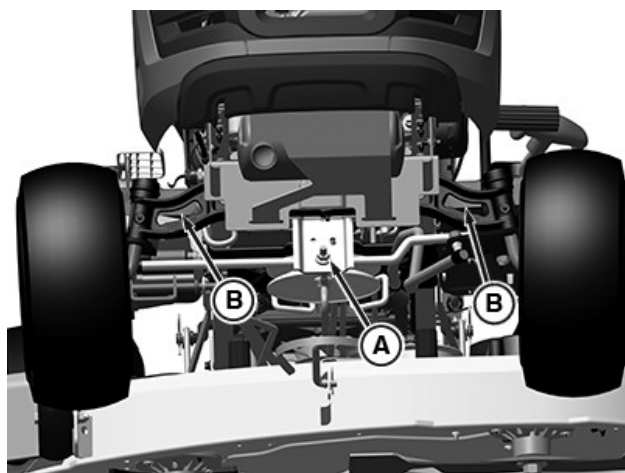

2. Safely lift and support machine. Place safe lifting device under end of front hanger bracket at location (A), and place jackstands or other stable supports under frame on each side at location (B). Block wheels remaining on the ground to prevent machine movement.



3. Remove plastic cap (C) from end of wheel hub.

⚠ CAUTION: Avoid injury! Components are installed under spring tension. Wear eye protection and use proper tools when installing and removing components with spring tension.



4. Remove snap ring (D) from end of axle.
5. Remove washer (E) and wheel from axle.

⚠ CAUTION: Avoid injury! Explosive separation of tire and rim parts is possible when they are serviced incorrectly:

- Do not attempt to mount a tire without the proper equipment and experience to perform the job.

6. Take wheel assembly to a John Deere dealer or other service provider for repairs.

Installing

1. Grease spindles and wheel hub grease fittings with specified grease.
2. Install wheel and washer (E) on axle.
3. Install snap ring (D).
4. Install plastic cap (C).
5. Safely remove jackstands and lower machine.

SR99263,00002B1-19-17OCT25

Removing and Installing Rear Wheel Assembly

Removing

1. Park machine safely. (See Parking Safely in the Safety section.)

⚠ CAUTION: Avoid injury! The machine can fall or slip from an unsafe lifting device or supports.

- Use a safe lifting device rated for the load to be lifted.
- Lower machine onto jackstands or other

stable supports and block wheels before servicing.

IMPORTANT: Avoid damage! Place jackstands under frame, not under transmission or engine, when raising or supporting machine.

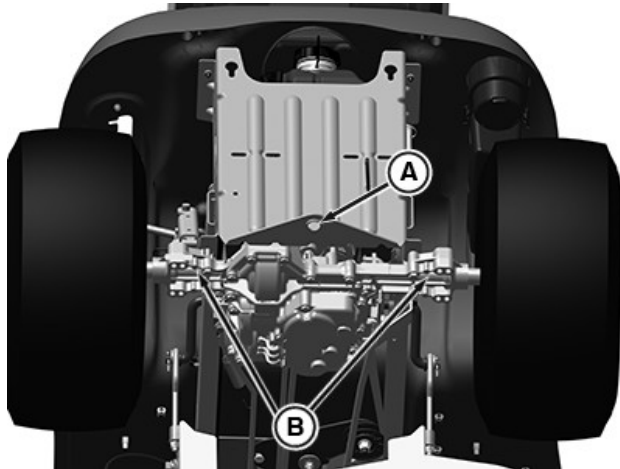

APY36180—UN—10JUL20

2. Safely lift and support machine. Place safe lifting device under transmission centered under machine frame point (A). Place jackstands or other stable supports on each side (B) where mounting bolts for frame come through. Block wheels remaining on the ground to prevent machine movement.

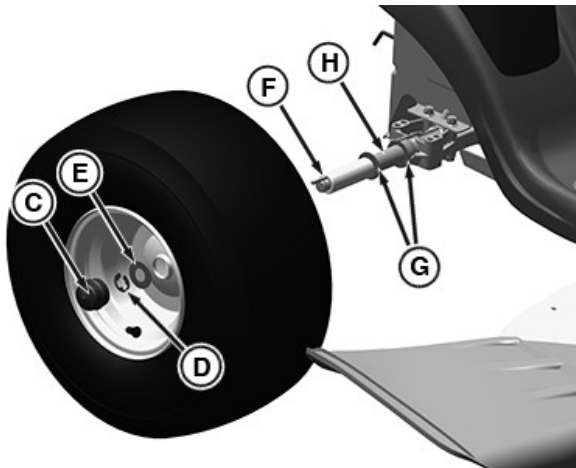

APY36185—UN—10JUL20

3. Remove plastic cap (C), snap ring (D), and washer (E).
4. Remove wheel.

IMPORTANT: Avoid damage! Do not lose the shaft key. Key must be installed for wheels to rotate and tractor to move.

5. Remove shaft key (F) (shown on end of transmission shaft), two washers (G), except for model S100, and spacer (H).

CAUTION: Avoid injury! Explosive separation of tire and rim parts is possible when they are serviced incorrectly:

- Do not attempt to mount a tire without the proper equipment and experience to perform the job.

6. Take wheel assembly to a John Deere dealer or other service provider for repairs.

Installing

IMPORTANT: Avoid damage! Do not lose the shaft key. Key must be installed for wheels to rotate and tractor to move.

NOTE: Rear wheels are installed with valves to the outside.

1. Install two washers (G), except on model S100, spacer (H), and shaft key (F).
2. Install rear wheel, washer (E), snap ring (D), and plastic cap (C).
3. Safely remove jackstands and lower machine.

SR99263,00002F1-19-17OCT25

Troubleshooting

Using Troubleshoot Chart

If you are experiencing a problem that is not listed in this chart, see your Technical Manual, dealer, or other service provider for service.

MP47322,00F467B-19-17OCT25

Engine

IF	CHECK
Poor Engine Performance	Dirt in fuel system or fuel is old. Replace fuel with fresh stabilized fuel. Obtain fuel from another supplier before suspecting machine problems. Suppliers blend fuels differently and changing suppliers will generally solve any performance problems. Fuel blended with alcohol or ether may contribute to performance problems by causing gum and varnish deposits, especially if fuel is stored for several weeks or more. Obtain fresh fuel.
Engine Will Not Start	Brake pedal not depressed. Mower is engaged. Spark plug wire is loose or disconnected. Improper fuel. Transmission is in reverse. Plugged fuel filter. Defective safety switch. Electrical problem - See Electrical Troubleshooting Section
Engine Is Hard To Start	Choke cable not adjusted properly. Plugged fuel filter. Faulty spark plug. Stale or improper fuel. Loose or corroded electrical connections. Improper engine oil viscosity.
Engine Runs Unevenly	Cooling fins plugged. Loose electrical connections. Choke or throttle cable sticking. Fuel line or fuel filter plugged. Stale or dirty fuel. Improper fuel. Air cleaner element plugged.
Engine Misses Under Load	Faulty spark plug. Stale or dirty fuel. Plugged fuel filter.
Engine Vapor Locks	Fuel tank vent plugged. Dirt in fuel filter. Cooling fins plugged. Loose hose connection at fuel filter or fuel pump.
Engine Overheats	Engine air intake screen plugged. Cooling fins plugged. Engine oil low or too high. Engine operated too long at a slow idle speed.

IF	CHECK
Engine Will Not Idle	Spark plug not gapped correctly. Faulty spark plug. Operator raising off the seat.
Engine Knocks	Stale or low octane fuel. Engine overloaded. Low engine speed. Oil level low.
Engine Stops Or Misses When Operating On Hillsides	Fuel tank less than half full of fuel. Operator raising off of the seat.
Engine Backfires	Faulty spark plug. Operator raising off of the seat.
Engine Loses Power	Engine overheating. Too much oil in engine. Dirty air cleaner. Faulty spark plug. Travel speed is too fast for conditions. Improper fuel.
Excessive Fuel Consumption	Choke is not fully open.
Black Exhaust Smoke	Air filter is dirty or oil soaked. Choke partially engaged.
Engine Stops When REVERSE Foot Pedal Is Depressed And Attachment Is Engaged (Hydrostatic)	Normal condition. (See Using Reverse Implement Option in the OPERATING section.)
Engine Stops When Automatic Shift Lever Is Moved To The R (REVERSE) Position and Attachment Is Engaged (Automatic)	Normal condition. (See Using Reverse Implement Option in the OPERATING section.)

RM87422,00002A4-19-06JUL15

Electrical

IF	CHECK
Starter Does Not Work Or Will Not Turn Engine	Brake pedal is not depressed. Mower is engaged. Battery terminals are corroded. Battery not charged. Transmission is in reverse. Blown fuse.
Battery Will Not Charge	Dead cell in the battery. Battery cables and terminals are dirty. Low engine speed or excessive idling.
Lights Do Not Work	Light plug disconnected. Loose or burned out bulb.
The fuel level indicator flashes "E33" intermittently or shows full bars constantly when fuel tank is not full	Check the fuel sender connector located beneath the seat for full and proper connection. If connections are good but the problem persists, contact your John Deere Dealer or other service provider.

MG39705,00004DB-19-29JUL25

Tractor

IF	CHECK
Tractor Vibrates Too Much Or Rattles Excessively	Attachment drive belts worn or damaged. Traction drive belt damaged or worn. Dirt on drive sheaves. Blades bent or out of balance.
Tractor Will Not Move With Engine Running	Parking brake locked. Bypass rod is pulled out.

OOU1023,00001EB-19-19JUN15

Mower

IF	CHECK
Discharge Chute Plugged	Travel speed too fast. Grass too long. Grass too wet. Engine rpm not at wide open throttle. Restricted air flow. Belt installed incorrectly.
Patches Of Grass Uncut	Travel speed too fast. Engine rpm not at wide open throttle. Mower deck needs cleaning.
Belt Slipping	Debris in sheaves. Worn belt. Belt tension is incorrect.
Too Much Vibration	Debris on mower deck or in sheaves. Damaged drive belt. Damaged sheaves or sheaves out of alignment. Blades out of balance.
Blades Scalping Grass	Cutting too low. Mower wheels not adjusted correctly. Turning speed too fast. Ridges in terrain. Rough or uneven terrain. Low tire pressure.
Mower Loads Down Tractor	Engine rpm too low. Travel speed too fast. Debris wrapped around mower spindles.
Uneven Cut	Mower deck not leveled properly. Travel speed too fast. Blades dull. Mower wheels not adjusted correctly. Tire pressure unequal.
Mower (Or Other Attachment) Stops When Vehicle Is Operated in REVERSE	Normal condition. (See Using Reverse Implement Option in the OPERATING section.)

OOU1023,00001EC-19-19JUN15

Storage

Storing Safety

⚠ CAUTION: Avoid injury! Fuel vapors are explosive and flammable.

Engine exhaust fumes contain carbon monoxide and cause serious illness or death:

- Run the engine only long enough to move the machine to or from storage.
- If a machine is stored before allowing it to cool, machine fires and structure fires can occur. Fires can occur if debris is not removed from around the engine and muffler, or if stored near combustible materials.
- Do not store vehicle with fuel in the tank inside a building where fumes reach an open flame or spark.
- Allow the engine to cool before storing the machine in any enclosure.

MP47322,00F4680-19-06MAY15

Preparing Machine for Storage

1. Repair any worn or damaged parts. Replace parts if necessary. Tighten loose hardware.
2. To prevent rust, repair scratched or chipped metal surfaces.
3. Remove grass and debris from machine.
4. Clean under the rotary deck and remove grass and debris from inside chute and bagger, if applicable.
5. Wash the machine and apply wax to metal and plastic surfaces.
6. To dry belts and pulleys, run machine for five minutes.
7. To prevent rust, apply light coat of engine oil on pivot and wear points.
8. Lubricate grease points and check tire pressure.

MP47322,00F4681-19-13JUL16

Preparing Fuel and Engine For Storage

Fuel:

If you have been using "Stabilized Fuel," add stabilized fuel to tank until the tank is full.

NOTE: Filling the fuel tank reduces the amount of air in the fuel tank and helps reduce deterioration of fuel.

If you are not using "Stabilized Fuel":

1. Park machine safely in a well-ventilated area. (See Parking Safely in the Safety section.)

NOTE: Try to anticipate the last time the machine will be used for the season so very little fuel is left in the fuel tank.

2. Turn on engine and allow to run until it runs out of fuel.
3. For machines equipped with key switch, turn key to off position.

IMPORTANT: Avoid damage! Stale fuel can produce varnish and plug carburetor or injector components and affect engine performance.

- Add fuel conditioner or stabilizer to fresh fuel before filling tank.
4. Mix fresh fuel and fuel stabilizer in separate container. Follow stabilizer instructions for mixing.
 5. Fill fuel tank with stabilized fuel.
 6. Run engine for a few minutes to allow fuel mixture to circulate through carburetor on gas engine or fuel injectors on diesel engine.

Engine:

Engine storage procedure should be used when vehicle is not to be used for longer than 60 days.

1. Change engine oil and filter.
2. Service air filter if necessary.
3. Clean debris from engine air intake screen.
4. On gas engines:
 - Remove spark plugs. Put 30 mL (1 oz) of clean engine oil in cylinders.
 - Install spark plugs, but do not connect spark plug wires.
 - Crank the engine 5 or 6 times to allow oil to be distributed.
5. Clean the engine and engine compartment.
6. Remove battery.
7. Clean the battery and battery posts. Check the electrolyte level if your battery is not maintenance free.
8. Close fuel shutoff valve if your machine is equipped.
9. Store the battery in a cool, dry place where it will not freeze.

NOTE: The stored battery should be recharged every 90 days.

10. Charge the battery.

IMPORTANT: Avoid damage! Prolonged exposure to sunlight could damage surfaces. Store machine inside or use a cover if stored outside.

11. Store the vehicle in a dry, protected place. If vehicle is stored outside, put a waterproof cover over it.

RM87422.00007C9-19-19JUL17

Removing Machine From Storage

1. Check tire pressure.
2. Check engine oil level.
3. Check battery electrolyte level if your battery is not maintenance free. Charge battery if necessary.
4. Install battery.
5. On gas engines: check spark plug gap. Install and tighten plugs to specified torque.
6. Lubricate all grease points.
7. Open fuel shut-off valve if your machine is equipped.
8. Run the engine 5 minutes without the mower or any attachments running to allow oil to be distributed throughout engine.
9. Be sure all shields and guards or deflectors are in place.

MP47322.00F4683-19-17FEB23

Specifications

Model S100

Engine Model	Briggs & Stratton 31
Power Rating Information	www.briggsandstratton.com/
Displacement	500 cc (30.5 in ³)
Spark Plug Gap	0.76 mm (0.030 in)
Spark Plug Torque	20 N·m (15 lb·ft)
Cylinders	Single
Oil Filter	Standard
Air Filter	Cartridge
Transmission	Hydrostatic
Transaxle Model	TL200
Travel Speed - Forward	0—8.9 km/h (0—5.5 mph)
Travel Speed - Reverse	0—4.8 km/h (0—3.0 mph)

SDHTXN6,1748836442854-19-01JUN25

Models S170 and S180

Engine Model	Briggs & Stratton 44
Power Rating Information	www.briggsandstratton.com/
Displacement	724 cc (44.2 in ³)
Spark Plug Gap	0.76 mm (0.030 in)
Spark Plug Torque	20 N·m (15 lb·ft)
Cylinders	Twin
Oil Filter	John Deere Easy Change 30-Second Oil Change System
Air Filter	Cartridge
Transmission	Hydrostatic
Transaxle Model	Tuff Torq HD K46
Travel Speed - Forward	0—8.9 km/h (0—5.5 mph)
Travel Speed - Reverse	0—4.8 km/h (0—3.0 mph)

SDHTXN6,1748836510499-19-01JUN25

Model S110

Engine Model	Briggs & Stratton 33
Power Rating Information	www.briggsandstratton.com/
Displacement	540 cc (33 in ³)
Spark Plug Gap	0.76 mm (0.030 in)
Spark Plug Torque	20 N·m (15 lb·ft)
Cylinders	Single
Oil Filter	Standard
Air Filter	Cartridge
Transmission	Hydrostatic
Transaxle Model	TL200
Travel Speed - Forward	0—8.9 km/h (0—5.5 mph)
Travel Speed - Reverse	0—4.8 km/h (0—3.0 mph)

SDHTXN6,1748836456580-19-01JUN25

Electrical System

Charging System	Regulated Circuit
Charging System Capacity (S100, S110, S120, S130, and S140)	9 Amp
Charging System Capacity (S160, S170, and S180)	16 Amp
Battery Voltage	12 Volts
Battery Type	BCI Group U1

SR99263,0000339-19-12MAY20

Fuel System (All Models)

Fuel Types (Recommended):	
	Regular Grade 87 Octane Unleaded Fuel
	Ethanol Blended Fuel (Up to 10%)
	MTBE Reformulated Fuel (Up to 15%)

OUO1023,00001F8-19-01MAR13

Models S120, S130, S140, and S160

Engine Model	Briggs & Stratton 44
Power Rating Information	www.briggsandstratton.com/
Displacement	724 cc (44.2 in ³)
Spark Plug Gap	0.76 mm (0.030 in)
Spark Plug Torque	20 N·m (15 lb·ft)
Cylinders	Twin
Oil Filter (If Equipped)	John Deere Easy Change 30-Second Oil Change System
Air Filter	Cartridge
Transmission	Hydrostatic
Transaxle Model	TL200
Travel Speed - Forward	0—8.9 km/h (0—5.5 mph)
Travel Speed - Reverse	0—4.8 km/h (0—3.0 mph)

SDHTXN6,1748836490808-19-01JUN25

Tires

Models S100, S110, S120, and S140

Size (Front)	15 x 6.00 - 6
Size (Rear)	20 x 8.0 - 8
Tire Pressure (Front)	97 kPa (14 psi)
Tire Pressure (Rear)	69 kPa (10 psi)

Models S130 and S160

Size (Front)	15 x 6.00 - 6
Size (Rear)	20 x 10.0 - 8
Tire Pressure (Front)	97 kPa (14 psi)
Tire Pressure (Rear)	69 kPa (10 psi)

Models S170 and S180

Size (Front)	16 x 6.5 - 8
Size (Rear)	22 x 9.5 - 12

Specifications

Tire Pressure (Front) 83 kPa (12 psi)
Tire Pressure (Rear) 83 kPa (12 psi)
(Tire pressure information is also located on the sidewalls of the tires)

Cutting Height (Approximately) 2.5 -10.2 cm (1 - 4 in)
Cutting Width 107 cm (42 in)

SR99263,000014D-19-24JUL19

SR99263,000033A-19-07JUN21

Capacities

Models S100 and S110

Crankcase, with Oil Filter 1.4 L (1.5 qt)

Models S140

Crankcase, with Oil Filter 1.9 L (2.0 qt)

Models S120, S130, S160, S170, and S180

Crankcase, with Easy Change™ 30-Second Oil Change System 2.6 L (2.8 qt)

Fuel Tank (All Models) 9 L (2.4 gal)

Towing Capacity (All Models) 226.79 kg (500 lb)

SR99263,000033B-19-07MAY21

Dimensions

Height (S100 and S110) 108 cm (42.5 in)

Height (S120, S130, and S140) 113 cm (45.5 in)

Height (S160) 118 cm (46.46 in)

Height (S170 and S180) 118 cm (46.5 in)

Length (Overall)

(S100, S110, and S120) 175 cm (68.75 in)

Length (Overall) (S130) 186 cm (73.25 in)

Length (Overall) (S140) 177 cm (69.5 in)

Length (Overall) (S160) 191 cm (75.2 in)

Length (Overall) (S170 and S180) 194 cm (76.5 in)

Width (Mower Deck Chute Down)

(S100, S110, S120, and S130) 138 cm (54.4 in)

Width (Mower Deck Chute Down) (S160) 155 cm (61 in)

Width (Mower Deck Chute Down)

(S140 and S170) 152 cm (60 in)

Width (Mower Deck Chute Down) (S180) 174 cm (68.5 in)

Weight: S100 189 kg (415 lb)

Weight: S110 193 kg (423 lb)

Weight: S120 198 kg (436 lb)

Weight: S130 201 kg (443 lb)

Weight: S140 218 kg (479 lb)

Weight: S160 217.72 kg (480 lb)

Weight: S170 229 kg (504 lb)

Weight: S180 241 kg (530 lb)

SR99263,000033C-19-15MAY20

Mower Deck - 107 cm (42 in)

Blades Rotary 2

Blade Nut Torque (w/5/8 in. Nut) 88 N•m (65 lb-ft)

Mower Deck - 122 cm (48 in)

Blades Rotary 3

Blade Nut Torque (w/5/8 in. Nut) 88 N•m (65 lb-ft)

Cutting Height (Approximately) 2.5 -10.2 cm (1 - 4 in)

Cutting Width 122 cm (48 in)

SR99263,000014E-19-24JUL19

Mower Deck - 137 cm (54 in)

Blades Rotary 3

Blade Nut Torque (w/5/8 in. Nut) 88 N•m (65 lb-ft)

Cutting Height (Approximately) 2.5 -10.2 cm (1 - 4 in)

Cutting Width 137 cm (54 in)

SR99263,000014F-19-24JUL19

Recommended Lubricants

Engine Oil Turf-Gard OR Plus-4

Grease . . Grease-Gard Premium Plus . . John Deere Multi-Purpose HD Lithium Complex Grease

(Specifications and design subject to change without notice.)

gvg6119,1716186699181-19-20MAY24

Warranty

Product Warranty

John Deere offers a standard warranty on new John Deere products. For a copy of the product warranty statement or for details on the warranty terms and conditions for products purchased in the United States and Canada, please contact your local John Deere Dealer or utilize the following resources:

United States

Website:

http://www.deere.com/en_US/services_and_support/warranty/warranty.page

Toll Free: 1-800-537-8233

Dealer Locator:

<http://dealerlocator.deere.com/servlet/country=US>

Canada

Website (English):

http://www.deere.ca/en_CA/services_and_support/service_plans_warranties/service_plans_warranties.page

Website (French):

http://fr.deere.ca/en_CA/services_and_support/service_plans_warranties/service_plans_warranties.page

Toll Free: 1-800-537-8233

Dealer Locator:

<http://dealerlocator.deere.com/servlet/country=CA>

Emission-related warranties are included in this Operator's Manual, and applicable if required by law or regulation.

For products purchased in a country other than the United States or Canada, please contact your local John Deere dealer for assistance.

MP47322,00F4690-19-27FEB24

U.S. EPA Emission Control System Warranty Statement (Off-Road Engine Equipment)

Your Warranty Rights and Obligations

John Deere and the United States Environmental Protection Agency are pleased to explain the emission control system's warranty on your off-road engine equipment. John Deere must warrant the emission control system on your off-road engine equipment for the period listed below provided there has been no abuse, neglect or improper maintenance of your off-road engine equipment leading to the failure of the emission control system.

Manufacturer's Warranty Coverage

Your evaporative emission control system is warranted for two years. Your off-road engine is warranted as follows: If your off-road engine equipment has a Briggs & Stratton engine, your off-road engine is warranted for two years. For all other off-road engines referenced in this Operator's Manual, your off-road engine is warranted for three years. If any emission-related part on your off-road equipment is defective, the part will be repaired or replaced by John Deere or an authorized John Deere service provider.

Owner's Warranty Responsibilities

- As the spark ignited off-road engine equipment owner, you are responsible for the performance of the required maintenance listed in your Operator's Manual. John Deere recommends that you retain all receipts covering maintenance on your spark ignited off-road engine equipment, but John Deere cannot deny warranty coverage solely for lack of receipts or for your failure to ensure the performance of all scheduled maintenance.
- As the spark ignited off-road engine equipment owner, you should however be aware that John Deere may deny you warranty coverage if your spark ignited off-road engine equipment or a part has failed due to abuse, neglect, or improper maintenance or unapproved modifications.
- You are responsible for presenting your spark ignited off-road engine equipment to a John Deere Turf and Compact Utility distribution center or service center as soon as a problem exists. The warranty repairs shall be completed in a reasonable amount of time, not to exceed 30 days. If you have a question about your emission control warranty coverage, your emission control warranty rights and responsibilities, how to make an emission control system warranty claim or how to make arrangements for emission-related authorized repairs, you should contact your John Deere Turf and Compact Utility retailer, or the John Deere Customer Contact Center at 1-800-537-8233, or email John Deere from

<https://www.deere.com/en/our-company/contact-us/>.

General Emission Control System Warranty Coverage

The warranty period begins on the date the spark ignited off-road engine equipment is delivered to an ultimate purchaser. John Deere warrants to the ultimate purchaser and each subsequent purchaser that the spark ignited off-road engine equipment is:

- Designed, built and equipped so it conforms at the time of sale to the ultimate purchaser with applicable U.S. Environmental Protection Agency regulations under 40 CFR Parts 1054, 1048 and 1060; and,
- Free from defects in materials and workmanship that causes the failure of a warranted part to conform with

applicable regulations for the emission control system warranty period provided herein.

- For owners located more than 100 miles from a John Deere authorized service center, John Deere will pay either for shipping costs to and from an authorized service center, provide for a service technician to come to the owner to make the warranty repair, or pay for the repair to be made at a local non-authorized service center. These provisions do not apply to high-altitude counties within the following States: Alaska, Hawaii, Arizona, Colorado, Idaho, Montana, Nebraska, Nevada, New Mexico, Oregon, Texas, Utah, and Wyoming.

Emission Control System Warranty Interpretation

- Any warranted part that is not scheduled for replacement as required by the maintenance instructions in the Operator's Manual is warranted as provided herein. If any such part fails during the period of warranty coverage it will be repaired or replaced by John Deere or an authorized John Deere service provider. Any such part repaired or replaced under warranty is warranted for the remaining warranty period.
- Any warranted part that is scheduled only for regular inspection in the maintenance instructions in the Operator's Manual is warranted as provided herein. A statement in the Operator's Manual to the effect of "repair or replace as necessary" does not reduce the period of warranty coverage. Any such part repaired or replaced under warranty is warranted for the remaining warranty period.
- Any warranted part that is scheduled for replacement as required maintenance in the Operator's Manual is warranted for the period of time prior to the first scheduled replacement point for that part. If the part fails prior to the first scheduled replacement, the part will be repaired or replaced by John Deere or an authorized John Deere service provider. Any such part repaired or replaced under warranty is warranted for the remainder of the period prior to the first scheduled replacement point for the part.
- Repair or replacement of any warranted part under the warranty will be performed at no charge to the owner by John Deere or an authorized John Deere service provider.
- The owner will not be charged for diagnostic labor which leads to the determination that a warranted part is defective, provided such work is performed by John Deere or an authorized John Deere service provider.
- John Deere or an authorized John Deere service provider will repair damages to other engine components proximately caused by a failure under warranty of any emission-related warranted part.
- Add-on or modified parts that are not exempted by the California Air Resources Board may not be used. The use of any non-exempted add-on or modified

parts will be grounds for disallowing a warranty claim. John Deere or any authorized John Deere service provider will not be liable to warrant failures of warranted parts caused by the use of a non-exempted add-on or modified part.

Emission Control System Warranty Parts List

Coverage under this warranty includes, but is not limited to, the parts listed below (the emission control system parts) to the extent these parts were on the off-road equipment and engine purchased.

Fuel Metering System:

- Carburetor and internal parts (or fuel injection system)
- Air/fuel ratio feedback and control system
- Cold start enrichment system

Evaporative System:

- Fuel tank, fuel cap and tether
- Fuel hose, line, fittings, clamps
- Fuel pump, fuel shut-off valve
- Fuel vapor hoses, fittings
- Carbon canister
- Rollover/slant valve for fuel vapor control
- Purge and vent line

Air Induction System:

- Air cleaner
- Intake manifold

Ignition System:

- Spark plugs
- Magneto or electronic ignition system
- Spark advance/retard system
- Gaskets

Lubrication System:

- Oil pump and internal parts

Positive Crankcase Ventilation (PCV) System

- PCV Valve
- Oil filler cap

Exhaust System:

- Exhaust manifold
- Catalyst muffler

Miscellaneous Items Used in Above Systems

- Valves and Switches: vacuum, temperature, position, check, time-sensitive
- Electronic controls
- Hoses, belts, connectors and assemblies

Limited Liability

a) The liability of John Deere under this emission control system warranty is limited solely to the remedying of defects in materials or workmanship. Except as otherwise expressly provided herein, this warranty does not cover inconvenience or loss of use of the off-road equipment or engine or transportation of the equipment or engine to or from the John Deere Turf and Compact Utility retailer or authorized service provider. John Deere shall not be liable for any other expense, loss, or damage, whether direct, incidental, consequential (except as listed above under "coverage") or exemplary arising in connection with the sale or use of or inability to use the off-road equipment or engine for any other purpose.

b) No express emission control system warranty is given by John Deere with respect to the equipment or engine except as specifically set forth in this document. Any emission control system warranty implied by law, including any warranty of merchantability or fitness for a particular purpose, is expressly limited to the emission control system warranty terms set forth in this document.

c) No dealer or service provider is authorized to modify this Federal, California and John Deere Emission Control System Warranty.

mk71445,1710421168405-19-22MAR24

Tire Warranty

John Deere warranty applies for tires available through the John Deere parts system. For tires not available through the John Deere parts system, the tire manufacturer's warranty applicable to your machine may not apply outside the U.S. (See your John Deere dealer for specific information.)

MX00654,0000314-19-21AUG14

Limited Battery Warranty For Factory Installed Batteries

NOTE: Applicable in North America only. For complete machine warranty, reference a copy of the John Deere warranty statement. Contact your John Deere dealer to obtain a copy.

TO SECURE WARRANTY SERVICE

The purchaser must request warranty service from a John Deere dealer authorized to sell John Deere

batteries, and present the battery to the dealer with the top cover plate codes intact.

FREE REPLACEMENT PERIOD

Any new battery which becomes unserviceable (not merely discharged) due to defects in material or workmanship within the FREE REPLACEMENT PERIOD will be replaced free of charge. Installation costs will be covered by warranty if the unserviceable battery was installed by a John Deere factory or dealer and the replacement battery is installed by a John Deere dealer.

PRO RATA ADJUSTMENT (batteries with letter code identification only)

Any new battery which becomes unserviceable (not merely discharged) due to defects in material or workmanship within the Pro Rata Warranty Period will be replaced upon payment of the battery's current list price less a pro rata credit for unused months of service. The applicable adjustment period is determined from the Warranty Code printed at the top of the battery and table below. Installation costs are not covered after the battery warranty period has ended.

THIS WARRANTY DOES NOT COVER

- A. Breakage of the container, cover, or terminals.
- B. Depreciation or damage caused by lack of reasonable and necessary maintenance or by improper maintenance.
- C. Transportation, mailing, or service call charges for warranty service.
- D. Batteries that are merely discharged.

LIMITATION OF IMPLIED WARRANTIES AND PURCHASER'S REMEDIES

To the extent permitted by law, neither John Deere nor any company affiliated with it makes any warranties, representations, or promises as to the quality, performance or freedom from defect of the products covered by this warranty. IMPLIED WARRANTIES OF MERCHANTABILITY AND FITNESS FOR A PARTICULAR PURPOSE, TO THE EXTENT APPLICABLE, SHALL BE LIMITED IN DURATION TO THE APPLICABLE ADJUSTMENT PERIOD SET FORTH HERE. THE PURCHASER'S ONLY REMEDIES IN CONNECTION WITH THE BREACH OR PERFORMANCE OF ANY WARRANTY ON JOHN DEERE BATTERIES ARE THOSE SET FORTH HERE. IN NO EVENT WILL THE DEALER, JOHN DEERE OR ANY COMPANY AFFILIATED WITH JOHN DEERE BE LIABLE FOR INCIDENTAL OR CONSEQUENTIAL DAMAGES. (Note: Some states do not allow limitations on how long an implied warranty lasts or the exclusion or limitation of incidental or consequential damages. So these limitations and exclusions may not apply to you.) This warranty gives you specific legal rights, and you may also have some rights which vary from state to state.

NO DEALER WARRANTY

The selling dealer makes no warranty of its own and the dealer has no authority to make any representation or promise on behalf of John Deere, or to modify the terms or limitations of this warranty in any way.

WARRANTY TERMS TABLE

NOTE: If your battery is not labeled with a warranty code, it is a warranty code 6.

Warranty Code	Free Replacement Period	Pro Rata Warranty Period
A	90 Days	40 Months
B	90 Days	36 Months
C	90 Days	24 Months
D	12 Months	48 Months
E	90 Days	12 Months
F	90 Days	60 Months
G	12 Months	60 Months
H	12 Months	60 Months
6	6 Months	0 Months
12	12 Months	0 Months
18	18 Months	0 Months

OUMX068.0000504-19-18OCT24



John Deere Quality Statement

John Deere Quality

John Deere equipment is more than just a purchase, it's an investment in quality. That quality goes beyond our equipment to your John Deere dealer's parts and service support. This support is needed to keep you a satisfied customer.

That's why John Deere has initiated a process to handle your questions or problems, should they arise. The following three steps will help guide you through the process.

Step 1

Refer to your operator's manual

- A. It has many illustrations and detailed information on the safe and proper operation of your equipment.
- B. It gives troubleshooting procedures, and specification information.
- C. It gives ordering information for parts catalogs, service and technical manuals.
- D. If your questions are not answered in the operator's manual, then go to Step 2.

Step 2

Contact your dealer

- A. Your John Deere dealer has the responsibility, authority, and ability to answer questions, resolve problems, and fulfill your parts and service needs.
- B. First, discuss your questions or problems with your dealer's trained parts and service staff.
- C. If the parts and service people are unable to resolve your problem, see the dealership manager or owner.
- D. If your questions or problems are not resolved by the dealer, then go to Step 3.

Step 3

Contact John Deere

A. Your John Deere dealer is the most efficient source in addressing any concern, but if you are not able to resolve your problem after checking your operator's manual and contacting your dealer, contact John Deere for assistance.

B. For prompt, effective service, please have the following ready before you call:

- The name of the dealer with whom you've been working.
- Your equipment model number.
- Number of hours on machine (if applicable).
- Your serial number which you recorded on the inside front cover of this manual.
- If the problem is with an attachment, your attachment identification number.

C. Then call 1-800-537-8233 (United States and Canada) and our advisor will work with your dealer to investigate your concern. If you are outside the United States and Canada, visit the following website:

<https://www.deere.com/en/global-country-selector/>

Select your country and then click on the Contact Us link at the bottom of the page.

SP66632,00043A7-19-04AUG25

Slope Gauge

Slope Gauge Template

Hold up or copy this page and follow the directions below to use the Slope Gauge Template.

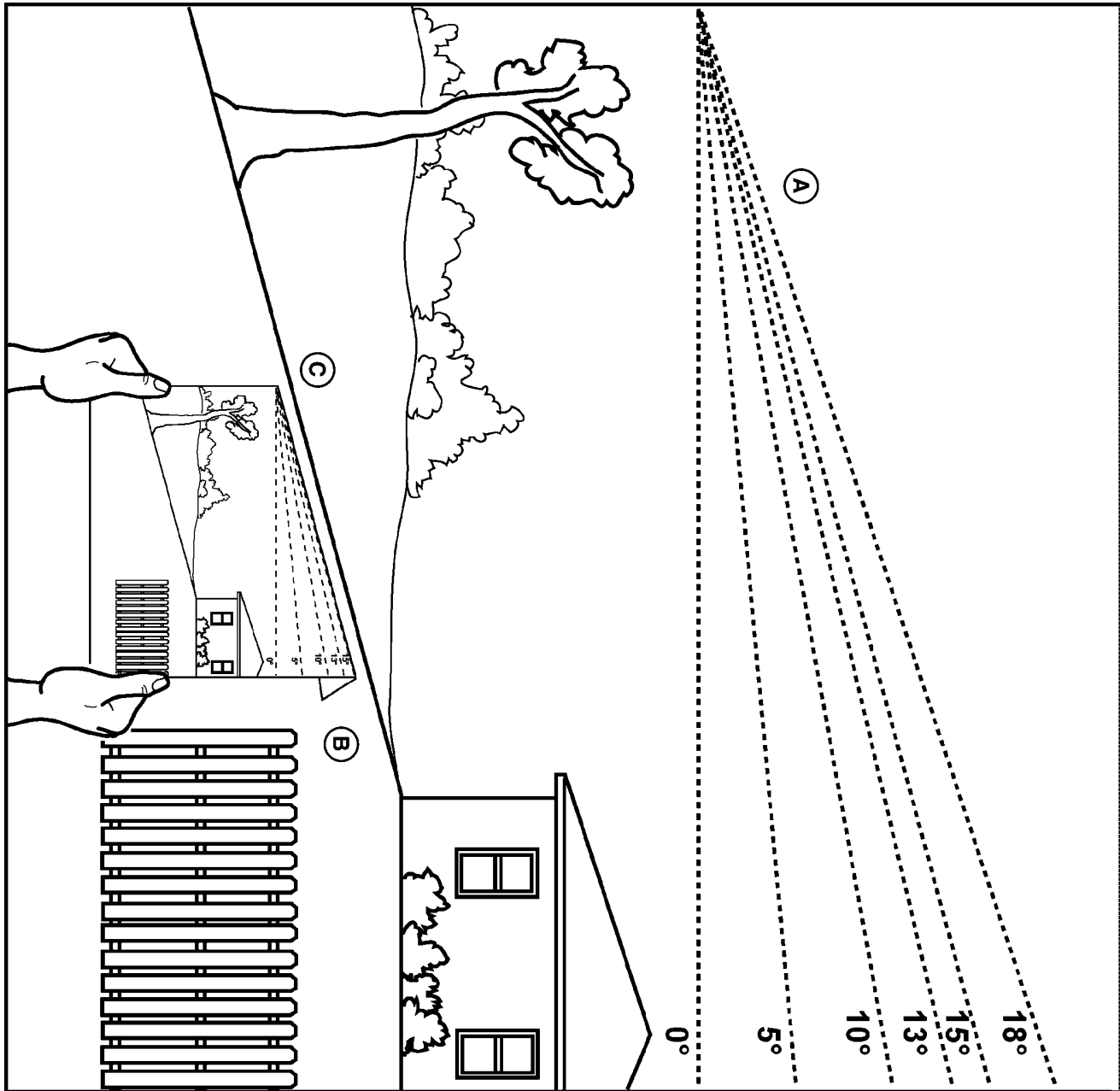

MXT013189—UN—22APR15

Use this slope gauge to determine if a slope is too steep for safe operation. Do not operate your machine on a slope greater than what is recommended in your operator's manual. See Operating on Slopes in the Safety section.

- Fold along the appropriate line (A) to match the recommended slope.
- Align this edge (B) with a vertical surface, a tree, building, fence pole, etc.
- Compare slope (C) with folded edge.

OUMX068,0000513-19-05JUL17

Index

A	
Accessories, using	30-12
Adjustment, Altitude	45-1
Attachment engagement switch or lever, testing	30-5
Axle, lubricating front	40-1

B	
Battery and Terminals, Cleaning	60-2
Battery, removing and installing	60-1
Battery, Service Safely	60-1
Battery, Using Booster	60-2
Belt, replacing mower drive (54 in. (137 cm) and 54 in. (137 cm) Decks)	55-4
Belt, replacing mower drive (107 cm (42 in.) mower deck)	55-3
Blades, balancing	55-6
Blades, Checking Mower	55-4
Blades, Servicing Mower	55-5
Blades, sharpening	55-5
Brake, using park	30-6
Bulb, replacing headlight	60-2

C	
Controls on hydrostatic transmission, using travel	30-8
Cruise control, using	30-9
Cutting height, adjusting	30-1

D	
Deck, adjusting mower level	30-1
Deck, installing mower	55-3
Deck, removing mower	55-1

E	
Electrical	60-1
Electrical troubleshooting	70-1
Emissions	
Required language	
EPA	2
Emissions Performance	
Tampering	2
Engine	
Oil	45-1
Engine fins, cleaning	45-4
Engine troubleshooting	70-1
Engine, idling	30-7
Engine, starting	30-7
Engine, stopping	30-8

F	
Filter, changing engine oil	45-3
Filter, Replacing Fuel	45-6
Four-cycle Engine, gasoline fuel	65-1
Fuel Storage	75-1
Fuel Tank, Filling	65-1

Fuse, replacing	60-3
-----------------------	------

G	
Gasoline fuel, four-cycle engine	65-1
Grease	40-1

H	
Headlights, using	30-7
Hood, removing and installing	65-2

I	
Identification numbers	00-1
Intervals for Service	35-1

J	
John Deere Quality	JDQS-1

L	
Labels, safety with text	05-2
Labels, safety without text	06-2
Lifting machine	65-1

M	
Material Collection System, Unplugging	30-10
Metal Surfaces, Repairing and Cleaning	65-3
Moving machine by hand	30-10
Mower blades, choosing	30-13
Mower deck, cleaning	30-10
Mower deck, engaging and disengaging	30-9
Mower deck, lubricating pivot points	40-1
Mower deck, removing and installing drive belt at engine sheave (122 cm (48 in.) and 137 cm (54 in.) decks)	55-1
Mower troubleshooting	70-2
Mowing tips	30-13
Mowing Tips	30-13

O	
Oil	
Engine	
Gasoline	45-1
Oil level, checking engine	45-2
Operating checklist, daily	30-1
Operator's Station Controls "Models S110 and S120"	25-1
Order Service Parts Online	3

P	
Park Brake, Testing	30-5
Parts	3
Plastic And Painted Surfaces, Avoid Damage To	65-3
Plastic surfaces, cleaning	65-3

R

Record service dates..... SR-1
Reverse implement option, testing 30-5
Reverse implement option, using the 30-9

S

Safety labels, with text 05-2
Safety labels, without text 06-2
Safety Systems, Testing 30-4
Seat, adjusting 30-1
Service Information, Emissions 45-1
Service Literature 3
Slopes, operating on
 Terrain hazards, operating near 10-2
Spark plug, checking 45-6
Special Messages 3
Storage, Preparing Machine for..... 75-1
Storage, Removing Machine from 75-2
Storing Safety 75-1
Switch, Testing Park Brake 30-5
Switch, Testing Seat..... 30-5

T

Template, slope gauge..... SG-1
Thank You for Purchasing a John Deere Product ... 2
Tire chains, using 30-12
Tire Pressure, Checking 65-2
Tractor troubleshooting..... 70-2
Trademarks 4
Transmission, Checking..... 50-1
Transporting machine on trailer 30-11
Transporting Material Collection System..... 30-12
Troubleshooting chart 70-1

W

Warranty Registration 00-1
Warranty, product..... 85-1
Weights, using 30-12
Wheel Assembly, Removing and Installing Front 65-4
Wheel Assembly, Removing and Installing Rear 65-4
Wheels, adjusting mower deck 30-4



