

SEARS OWNER'S MANUAL

MODEL NO.
536.797500

Caution:
Read and Follow
All Safety Rules
and Instructions
Before Operating
This Equipment

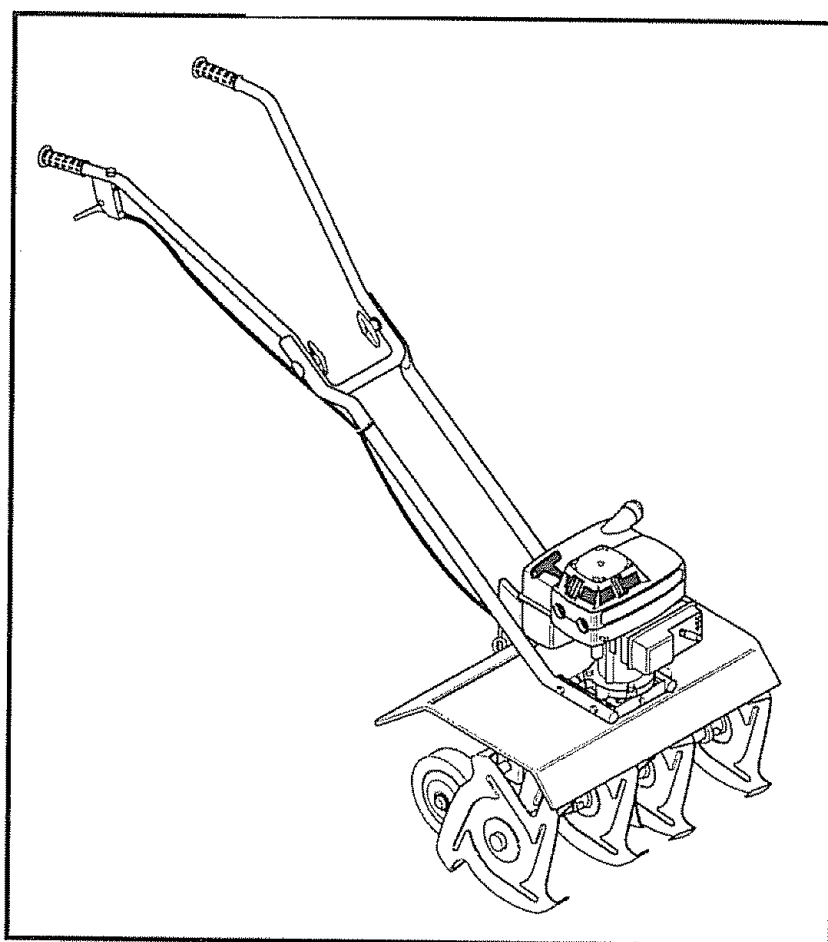

CRAFTSMAN®

32.8 cc 2-CYCLE
10 INCH DIAMETER TINES
MINI TILLER/CULTIVATOR

- Assembly
- Operation
- Customer Responsibilities
- Service and Adjustments
- Repair Parts

SEARS, ROEBUCK AND CO., Hoffman Estates 60179 U.S.A.

SAFETY RULES



CAUTION: ALWAYS DISCONNECT SPARK PLUG WIRE AND PLACE WIRE WHERE IT CANNOT CONTACT SPARK PLUG TO PREVENT ACCIDENTAL STARTING WHEN SETTING-UP, TRANSPORTING, ADJUSTING OR MAKING REPAIRS



IMPORTANT

SAFETY STANDARDS REQUIRE OPERATOR PRESENCE CONTROLS TO MINIMIZE THE RISK OF INJURY. YOUR MINI TILLER/CULTIVATOR IS EQUIPPED WITH SUCH CONTROLS. DO NOT ATTEMPT TO DEFEAT THE FUNCTION OF THE OPERATOR PRESENCE CONTROL UNDER ANY CIRCUMSTANCES.

BEFORE USE

- Read the owner's manual carefully. Be thoroughly familiar with the controls and the proper use of the mini tiller/cultivator. Know how to stop the mini tiller/cultivator and disengage the controls quickly.
- Do not operate the mini tiller/cultivator without wearing adequate outer garments. Wear footwear that will improve footing on slippery surfaces.
- Keep the area of operation clear of all persons, particularly small children and pets.
- Thoroughly inspect the area where the mini tiller/cultivator is to be used and remove all foreign objects.

FUEL SAFETY

- Handle fuel with care; it is highly flammable.
- Use an approved container
- Check fuel supply before each use, allowing space for expansion as the heat of the engine and/or sun can cause fuel to expand.
- Fill fuel tank outdoors with extreme care. Never fill fuel tank indoors. Replace fuel tank cap securely and wipe up spilled fuel.
- Never remove the fuel tank cap or add fuel to a running or hot engine.
- Never store fuel or mini tiller/cultivator with fuel in the tank inside a building where fumes may reach an open flame.

OPERATING SAFETY

- Never allow children or young teenagers to operate the mini tiller/cultivator. Keep them away while it is operating. Never allow adults to operate the mini tiller/cultivator without proper instruction.
- Always wear safety glasses or eye shields during operation or while performing an adjustment or repair to protect your eyes from foreign objects that may be thrown from the mini tiller/cultivator.
- Do not put hands or feet near or under rotating parts.
- Exercise extreme caution when operating on or crossing gravel drives, walks, or roads. Stay alert for hidden hazards or traffic.
- Exercise caution to avoid slipping or falling.
- Never operate the mini tiller/cultivator without proper guards, plates, or other safety protective devices in place.

- Never operate the mini tiller/cultivator at high transport speeds on slippery surfaces. Look behind and use care when backing.
- Never allow bystanders near the mini tiller/cultivator.
- Keep children and pets away while operating.
- Never operate the mini tiller/cultivator without good visibility or light.
- Do not run the engine indoors. The exhaust fumes are dangerous (containing CARBON MONOXIDE, an ODORLESS and DEADLY GAS).
- Take all possible precautions when leaving the mini tiller/cultivator unattended. Stop the engine.
- Do not overload the mini tiller/cultivator capacity by attempting to till too deep at too fast a rate.

SAFE STORAGE

- Always refer to the owner's manual instructions for important details if the mini tiller/cultivator is to be stored for an extended period.
- Never store the mini tiller/cultivator with fuel in the fuel tank inside a building where ignition sources are present such as water and space heaters, clothes dryers, and the like. Allow the engine to cool before storing in any enclosure.
- Keep the mini tiller/cultivator in safe working condition. Check all fasteners at frequent intervals for proper tightness.

REPAIR/ADJUSTMENTS SAFETY

- After striking a foreign object, stop the engine (motor). Remove the wire from the spark plug, and keep the wire away from the plug to prevent accidental starting. Thoroughly inspect the mini tiller/cultivator for any damage, and repair the damage before restarting and operating the mini tiller/cultivator.
- If the mini tiller/cultivator should start to vibrate abnormally, stop the engine (motor) and check immediately for the cause. Vibration is generally a warning of trouble.
- Stop the engine (motor) whenever you leave the operating position. Also, disconnect the spark plug wire before unclogging the tines and when making any repairs, adjustments, or inspections.
- When cleaning, repairing, or inspecting, shut off the engine and make certain all moving parts have stopped.
- Never attempt to make any adjustments while the engine is running (except when specifically recommended by the manufacturer).



LOOK FOR THIS SYMBOL TO POINT OUT IMPORTANT SAFETY PRECAUTIONS. IT MEANS-- ATTENTION!!! BECOME ALERT!!! YOUR SAFETY IS INVOLVED.

CONGRATULATIONS on your purchase of a Sears Craftsman Mini tiller/cultivator. It has been designed, engineered and manufactured to give you the best possible dependability and performance.

Should you experience any problem you cannot easily remedy, please contact your nearest Sears Service Center/Department. We have competent, well-trained technicians and the proper tools to service or repair this unit.

Please read and retain this manual. The instructions will enable you to assemble and maintain your mini tiller/cultivator properly. Always observe the "SAFETY RULES."

MODEL NUMBER 536.797500
DATE CODE _____
DATE OF PURCHASE _____
THE MODEL AND DATE CODE WILL BE FOUND ON A DECAL ON THE SIDE OF THE MINI TILLER/CULTIVATOR TINE SHIELD.
YOU SHOULD RECORD BOTH DATE CODE AND DATE OF PURCHASE AND KEEP IN A SAFE PLACE FOR FUTURE REFERENCE.

MAINTENANCE AGREEMENT

A Sears Maintenance Agreement is available on this product. Contact your nearest Sears Store for details

CUSTOMER RESPONSIBILITIES

- Read and observe the safety rules.
- Follow a regular schedule in maintaining, caring for and using your mini tiller/cultivator.
- Follow the instructions under "Customer Responsibilities" and "Storage" sections of this owner's manual.

PRODUCT SPECIFICATIONS

HORSE POWER:	1.6 hp
DISPLACEMENT:	2.0 cu. in. (32.8 c.c)
GASOLINE CAPACITY:	16 oz. Unleaded (Regular)
FUEL/OIL MIX RATIO:	24:1 Gas To Oil (5 Oz. Oil/ 1 Gal. Gas)
SPARK PLUG : (GAP .035 in.)	Champion CJ -8Y

WARNING: This unit is equipped with an internal combustion engine and should not be used on or near any unimproved forest-covered, brush-covered or grass-covered land unless the engine's exhaust system is equipped with a spark arrester meeting applicable local or state laws (if any). If a spark arrester is used, it should be maintained in effective working order by the operator.

In the state of California the above is required by law (Section 4442 of the California Public Resources Code). Other states may have similar laws. Federal laws apply on federal lands. A spark arrester/muffler is available through your nearest Sears Authorized Service Center (See REPAIR PARTS section in this manual)

LIMITED ONE-YEAR WARRANTY ON CRAFTSMAN MINI TILLER/CULTIVATOR

For one year from the date of purchase, when this Craftsman Mini tiller/cultivator is maintained, lubricated, and tuned up according to the operating and maintenance instructions in the owner's manual, Sears will repair, free of charge, any defect in material or workmanship

This warranty excludes tine(s), spark plug, and air cleaner which are expendable parts and become worn during normal use.

If this Mini tiller/cultivator is used for commercial or rental purposes, this warranty applies for only 30 days from the date of purchase. This warranty applies only while this product is in use the United States. WARRANTY SERVICE IS AVAILABLE BY RETURNING THE MINI TILLER/CULTIVATOR TO THE NEAREST SEARS SERVICE CENTER IN THE UNITED STATES.

This warranty gives you specific legal rights, and you may also have other rights which vary from state to state

SEARS, ROEBUCK AND CO., D817WA, Hoffman Estates, IL 60179 USA

TABLE OF CONTENTS

SAFETY RULES	2	SERVICE AND ADJUSTMENTS	16-17
PRODUCT SPECIFICATIONS	3	STORAGE	18
CUSTOMER RESPONSIBILITIES ... 3, 13-15		TROUBLE SHOOTING	19
WARRANTY	3	REPAIR PARTS	
TABLE OF CONTENTS	4	(MINI TILLER/CULTIVATOR)	20-25
CONTENTS OF SHIPPING CARTON	5	REPAIR PARTS (ENGINE)	26-29
ASSEMBLY	6-8	PARTS ORDERING/SERVICE	Back Cover
OPERATION	9-12		

INDEX

A		F		S	
Adjustments:		Fuel:		Safety Rules	2
Carburetor	17	Type	11	Service and Adjustments	16-17
Assembly	6-8	Storage	17	Carburetor	17
Tools Required	6			Specifications	3
To Assemble	6-8			Starting the Engine	11
				Stopping the Mini tiller/cultivator	10
C		G		Storage	
Carburetor Adjustment	17	General Recommendations	13		
Choke Control	9,11			T	
Check List:		Hand Grip		Table of Contents	4
Operation	8	Assembly	8	Throttle Control	
Maintenance	13			Assembly	8
Cleaning	15			Operation	9
Controls, Mini tiller/cultivator ... 9,10		L		Tilling Hints	12
Cultivating Hints	12	Lubrication:		Tines	
Customer Responsibilities ... 3,13-15		Mini tiller/cultivator	13	Replacement	16
General Recommendations	13	Engine	11	Troubleshooting Points	19
Lubrication	13,14				
Mini tiller/cultivator	13	O			
Air Cleaner, Engine	14	Operation	9-12		
Cylinder Exhaust Ports	14	Operating		W	
Spark Plugs	14	Your Mini tiller/cultivator	10	Warranty	2
		Options			
		Spark Arrestor	3		
E		P			
Engine:		Parts Bag	5		
Air Cleaner	14	Product Specifications	3		
Gas and Oil Mixture	11				
Preparation	10,11			R	
Starting	11	Repair Parts:			
Storage	17	Mini tiller/cultivator	20-25		
		Engine	26-29		

CONTENTS OF HARDWARE PACK

CONTENTS OF PARTS BAG (shown actual size)

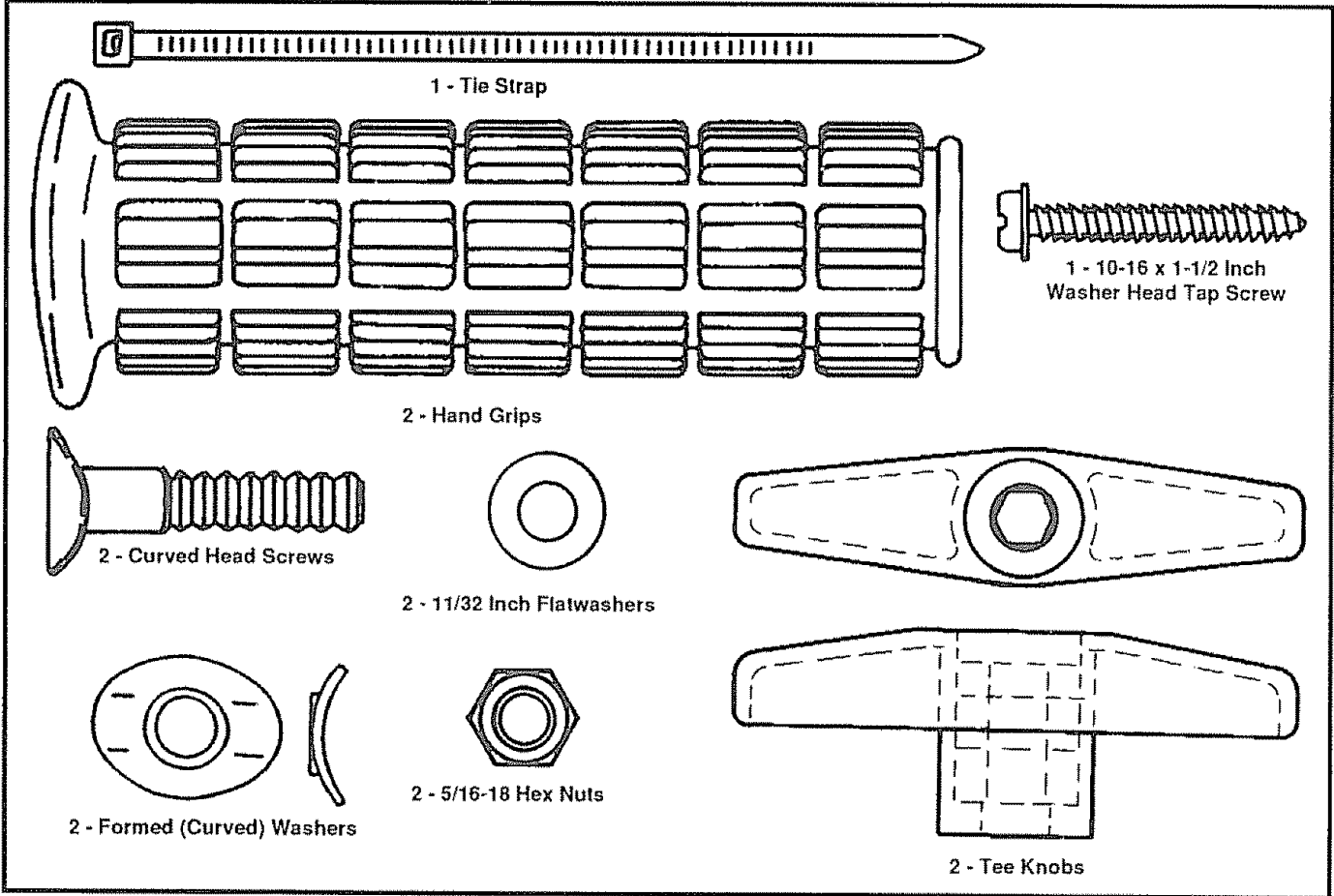

Parts packed separately in carton (not shown full size)

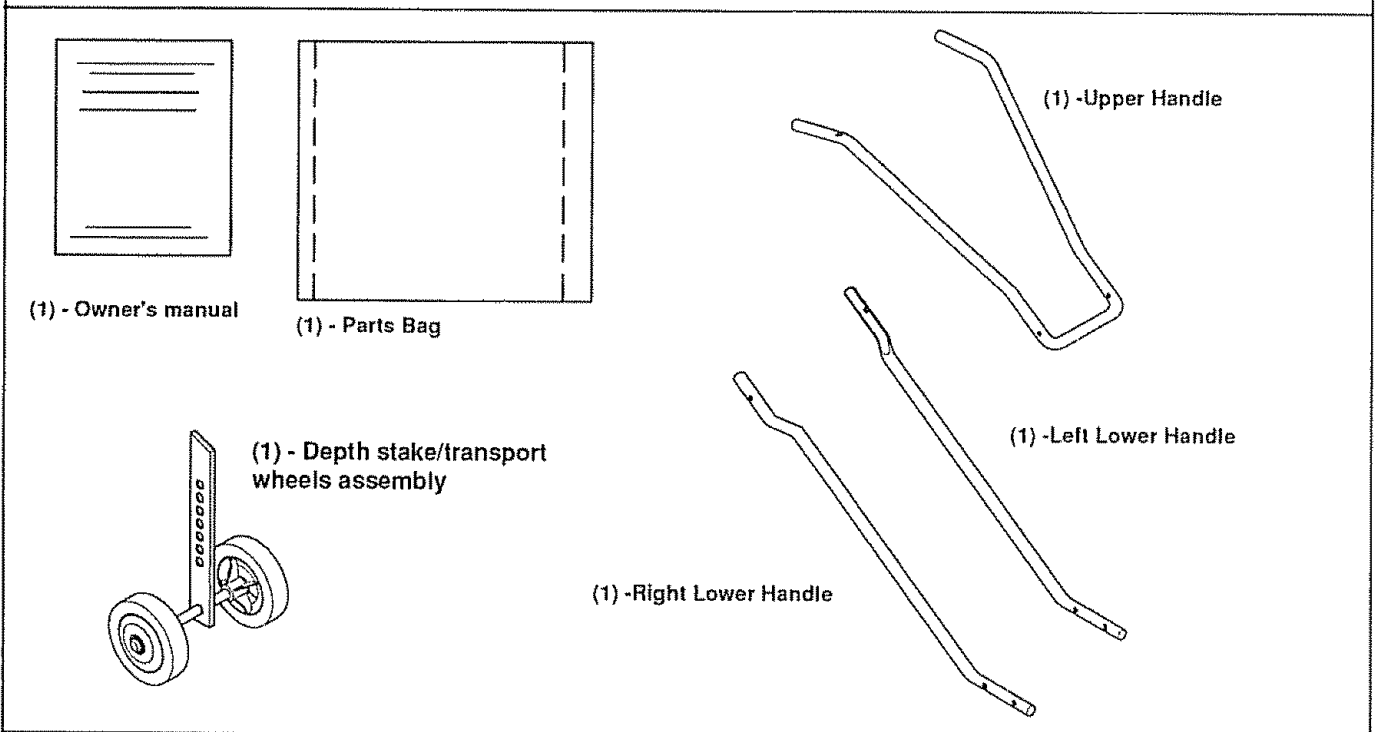

ASSEMBLY



CAUTION: ALWAYS WEAR SAFETY GLASSES OR EYE SHIELDS WHILE ASSEMBLING TILLER/ MINI TILLER/ CULTIVATOR.

TOOLS REQUIRED FOR ASSEMBLY

- 1 - 5/16 inch Wrench (or adjustable wrench)
- 2 - 7/16 inch Wrenches (or adjustable wrenches)
- 1 - Regular Screwdriver
- 1 - Pair Scissors
- 1 - Hammer

Figure 1 shows the mini tiller/cultivator completely assembled.

Reference to the right and left hand side of the mini tiller/cultivator is from the operator's position behind the unit.

TO REMOVE MINI TILLER/CULTIVATOR FROM CARTON

- Remove the plastic parts bag from the carton.
- Remove the handles from the carton.
- Remove packing insert from carton that contains depth stake/transport wheels assembly.
- Lift the tiller/mini tiller/cultivator out of the carton and place on a hard level surface.
- Remove packing material from around tines.

TO INSTALL THE HANDLE ASSEMBLY

The lower handles have a short bend at the bottom end and are flattened at the top to allow the upper handle to be placed between the lower handles. To assemble the handles, do the following:

- Unwind the throttle control from around the engine and straighten the cable. Be careful you do not kink the cable.
- Remove two locknuts, four washers and two handle mounting screws from the tine shield (see Fig. 2).

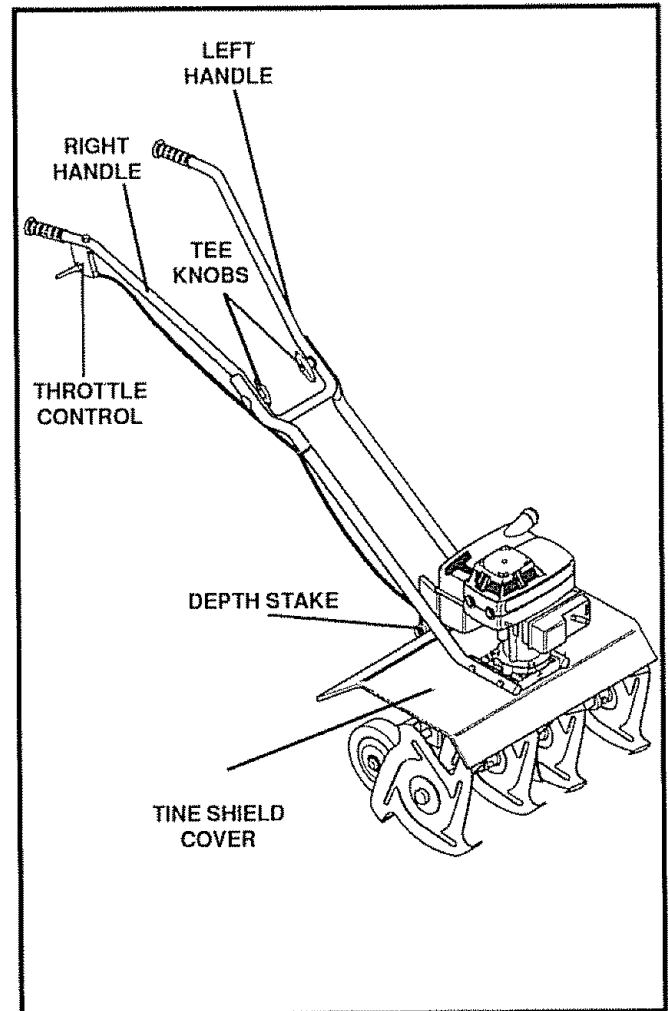

FIG. 1

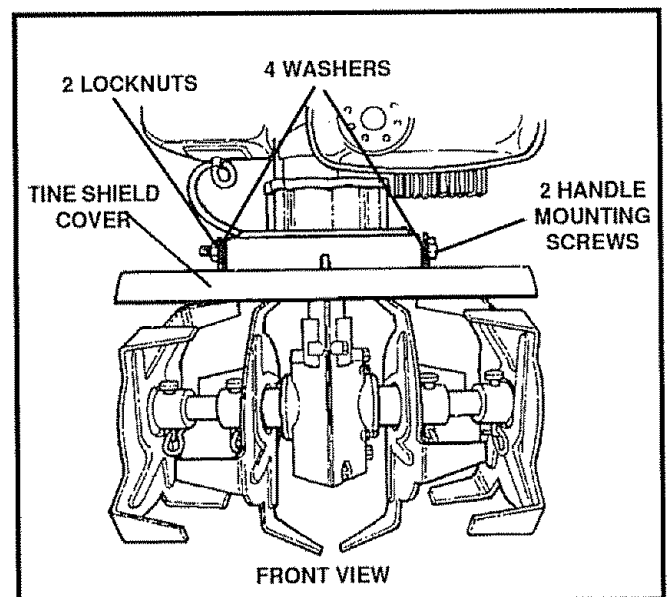

FIG. 2

ASSEMBLY

- Insert the right side lower handle section into the mounting channel between the tine shield and the engine casting (see Fig 3). Push the mounting screws through the tine shield, handle and approximately half way into the engine casting. Be sure a washer is on each mounting screw (see Fig. 4). It may be necessary to rotate the lower handle to align the mounting holes. To allow proper mounting of the upper handle section be sure the flat portion of the lower handle is facing inward.
- Position the left side lower handle section into the mounting channel between the tine shield and the engine casting. Align the holes in the handle with the engine casting and the tine shield, then push the mounting screws completely through the engine casting, handle and tine shield. Install a washer onto the mounting screws and secure the lower handle sections using two locknuts previously removed (see Fig. 4). Finger tighten the locknuts at this time
- Place the upper handle between the lower handles (see Fig. 5) and secure with two curved head carriage bolts, two formed washers, two 11/32 inch flatwashers and two tee knobs on the inside of the handle. **You must insert a hex nut into each tee knob.** Finger tighten only. Pull back on the tee knob to engage the hex opening with the hex nut. Tighten the tee knob. The nut will be pulled into the cavity and locked. The lower handles have two holes at the top end to allow the upper handle to be positioned at two different heights.
- Using two 7/16 inch wrenches, tighten the locknuts on the screws in the lower ends of the lower handles just enough to hold the lower handles firmly in place.

IMPORTANT: OVERTIGHTENING THE SCREWS ENOUGH TO CHANGE THE SHAPE OF THE HANDLES CAN RESULT IN DAMAGE TO THE ENGINE CASTING

- Hold the curved head carriage bolt against the outside of the lower handle while tightening the tee knobs securely (see Fig 5)

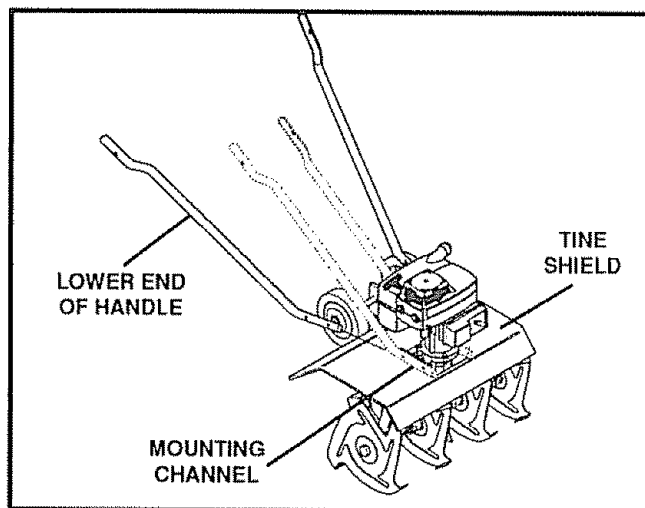

FIG. 3

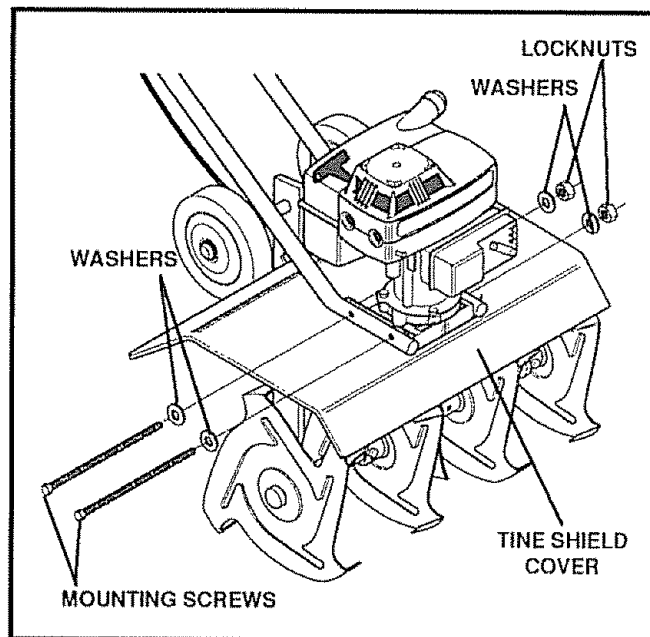

FIG. 4

ASSEMBLY

TO INSTALL THE THROTTLE CONTROL ASSEMBLY

- Place a No. 10 x 1-1/2 inch hex head screw down through the hole in the upper handle right side and attach the throttle control to the underside of the handle (see Fig 5).
- Attach the throttle cable to the right lower handle by threading a tie strap through the hole in the lower handle and around the throttle cable on the outside of the handle.
- Thread the pointed end of the strap through the other (square) end of the strap and pull tight around the throttle cable and lower handle.

NOTE: One side of the tie strap is rough, while the other side is smooth. The rough side must be on the inside of the loop formed when the ends of the tie strap are put together.

- Try to loosen the tie strap, if it will loosen, it is put together with the smooth side to the inside of the loop. Remove the tie strap and reverse the direction.
- Cut off excess strap.

HAND GRIP ASSEMBLY

- Install the hand grips onto the upper handles (see Fig. 5). It may be necessary to lubricate the handles with soap and water to aid assembly.

✓ CHECKLIST

BEFORE YOU OPERATE AND ENJOY YOUR NEW MINI TILLER/CULTIVATOR, WE WISH TO ASSURE THAT YOU RECEIVE THE BEST PERFORMANCE AND SATISFACTION FROM THIS QUALITY PRODUCT.

PLEASE REVIEW THE FOLLOWING CHECKLIST.

- ✓ All assembly instructions have been completed.
- ✓ No remaining loose parts in carton.
- ✓ All fasteners have been properly installed and tightened.

WHILE LEARNING HOW TO USE YOUR MINI TILLER/CULTIVATOR, PAY EXTRA ATTENTION TO THE FOLLOWING IMPORTANT ITEMS:

- ✓✓ Fuel tank is filled with correct gasoline and oil mixture.
- ✓✓ Become familiar with all controls-their location and function. Operate controls before starting engine.

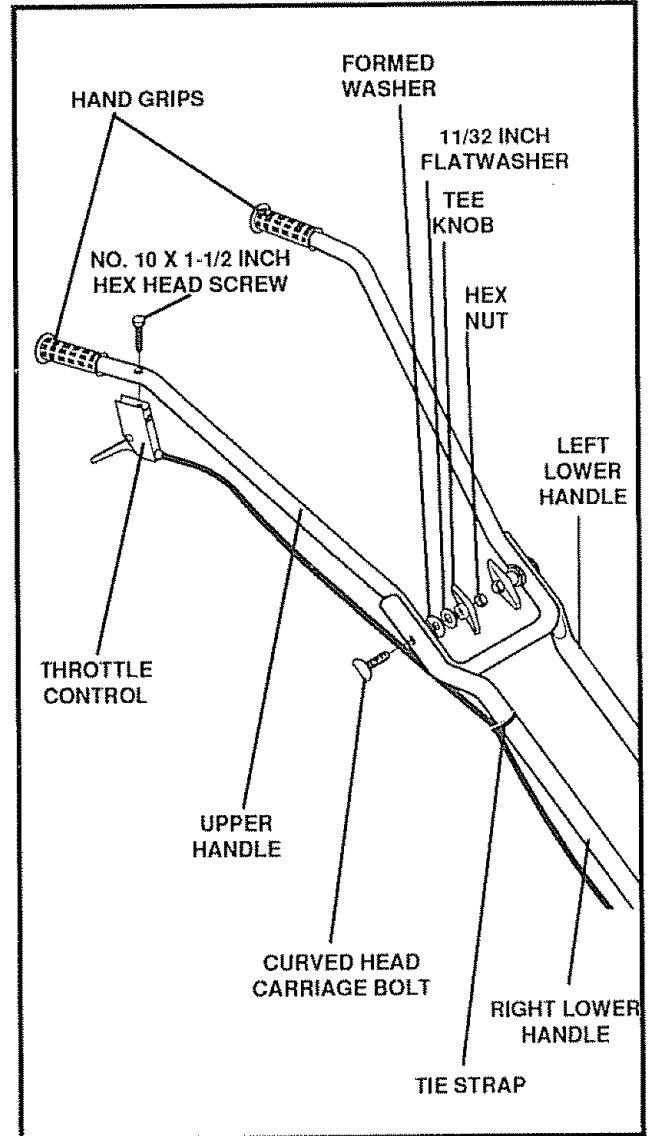

FIG. 5

OPERATION

KNOW YOUR MINI TILLER/CULTIVATOR

READ THIS OWNER'S MANUAL AND SAFETY RULES BEFORE OPERATING YOUR MINI TILLER/CULTIVATOR. Compare the illustrations with your mini tiller/cultivator to familiarize yourself with the location of various controls and adjustments. Save this manual for future reference

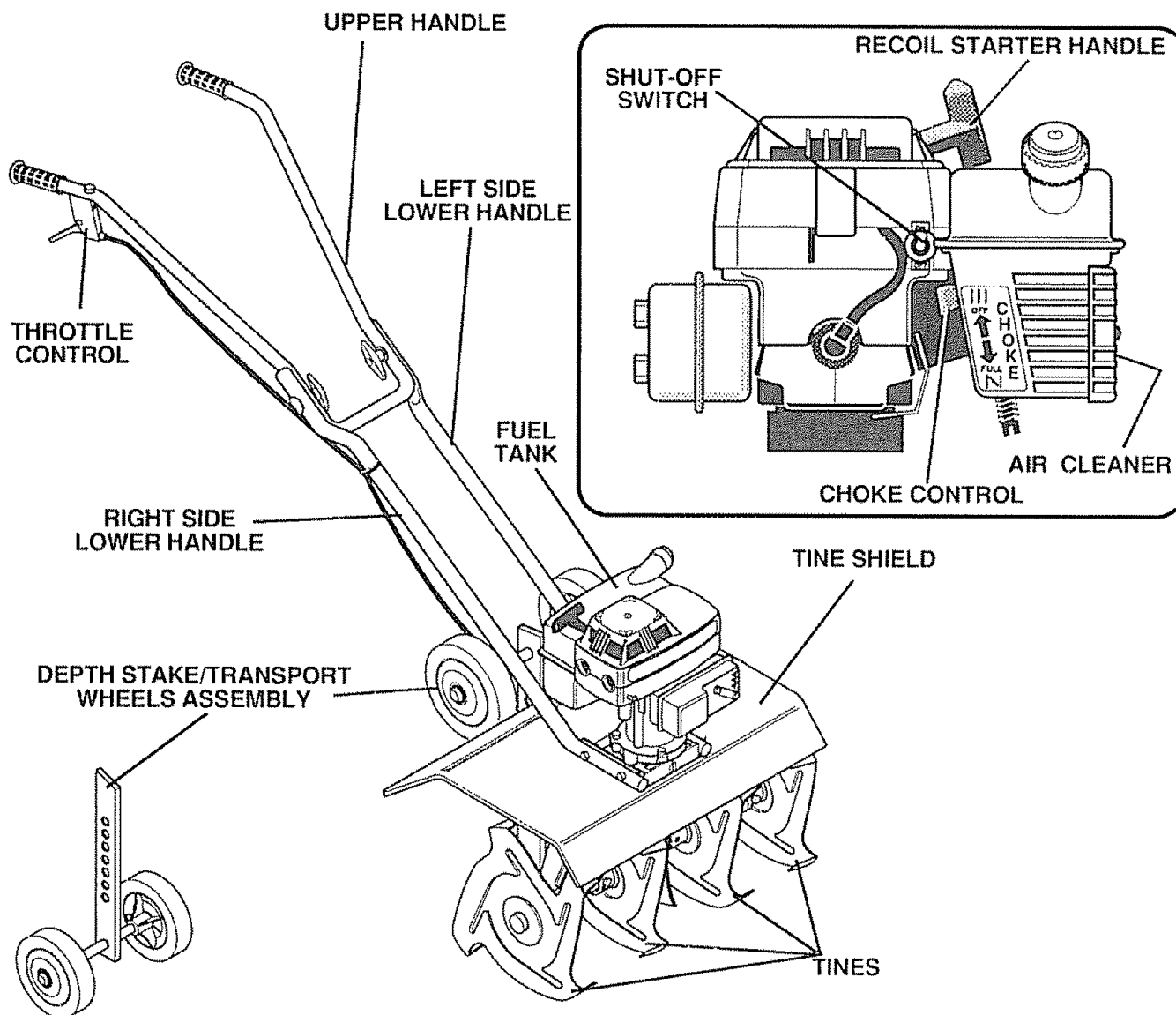

FIG. 6

SEARS MINI TILLER/CULTIVATOR conforms to the safety standards of the American National Standards Institute B71.8

THROTTLE CONTROL - Controls the engine speed and the tine rotation. This mini tiller/cultivator is equipped with a centrifugal clutch that engages the tine drive system when the engine speed is increased

CHOKE CONTROL LEVER - Used to assist in starting a cold engine.

SHUT-OFF SWITCH - Used to stop the engine

RECOIL STARTER HANDLE - The engine on this mini tiller/cultivator is equipped with an easy pull recoil starter

DEPTH STAKE/TRANSPORT WHEELS ASSEMBLY- Used (with wheels up) when tilling or cultivating to adjust the depth of the cut. It also acts as a brake to help the operator control the direction and speed of the unit

The depth stake/transport wheel assembly (with wheels down) can be used for transporting the unit.

OPERATION



The operation of this mini tiller/cultivator can result in foreign objects being thrown into the eyes, which can result in severe eye damage. Always wear safety glasses or eye shields while operating the mini tiller/cultivator.

We recommend standard safety glasses or Wide Vision Safety Mask for over your glasses.

TO STOP MINI TILLER/CULTIVATOR

- Release the throttle control to stop the tines.
- Move the shut-off switch on the engine to the "OFF" position.

TO OPERATE MINI TILLER/CULTIVATOR

- Set the depth stake/transport wheels assembly to the desired tilling position as follows:
- Remove the hairpin cotter from the clevis pin securing the depth stake (see Figure 8). Remove the clevis pin and adjust the depth stake upward to dig shallower or downward to dig deeper. Reinstall the clevis pin and hairpin cotter.
- Start the engine, tilt the unit back on the depth stake until the tines are off the ground and squeeze the throttle control all the way up against the hand grip. The engine is governor controlled and should be run at full throttle.
- Grasp the handles firmly and slowly tilt the unit forward to begin the tilling action.
- As the tines begin to make contact with the ground, hold back on the handles so that the tines will dig and not ride forward over the ground. Hold back until the tines dig into the soil.
- If the tilled depth is too deep or too shallow, turn off the engine and reset the depth stake.
- If depthstake is not controlling forward action, lower the depth stake. If the unit is not going forward, raise the depth stake.



CAUTION: KEEP AWAY FROM THE ROTATING TINES. ROTATING TINES CAN CAUSE INJURY.



CAUTION: GASOLINE IS FLAMMABLE AND CAUTION MUST BE USED WHEN HANDLING OR STORING IT. DO NOT FILL FUEL TANK WHILE MINI TILLER/CULTIVATOR IS RUNNING, HOT, OR WHEN MINI TILLER/CULTIVATOR IS IN AN ENCLOSED AREA. KEEP AWAY FROM OPEN FLAME, ELECTRICAL SPARK, AND DO NOT SMOKE WHILE MIXING FUEL OR FILLING THE FUEL TANK. NEVER FILL FUEL TANK COMPLETELY; BUT FILL THE TANK TO WITHIN 1/4 - 1/2 INCH FROM THE TOP TO PROVIDE SPACE FOR EXPANSION OF FUEL. ALWAYS FILL FUEL TANK OUTDOORS AND USE A FUNNEL OR SPOUT TO PREVENT SPILLING. MAKE SURE TO WIPE UP ANY SPILLED FUEL BEFORE STARTING THE ENGINE.

STORE GASOLINE IN A CLEAN, APPROVED CONTAINER, AND KEEP THE CAP IN PLACE ON THE CONTAINER. KEEP GASOLINE IN A COOL, WELL VENTILATED PLACE; NEVER IN THE HOUSE. NEVER BUY MORE THAN A 30 DAY SUPPLY OF GASOLINE TO ASSURE VOLATILITY. GASOLINE IS INTENDED TO BE USED AS A FUEL FOR INTERNAL COMBUSTION ENGINES; THEREFORE, DO NOT USE GASOLINE FOR ANY OTHER PURPOSE. SINCE MANY CHILDREN LIKE THE SMELL OF GASOLINE, KEEP IT OUT OF THEIR REACH BECAUSE THE FUMES ARE DANGEROUS TO INHALE, AS WELL AS BEING EXPLOSIVE.

BEFORE STARTING ENGINE

FILL GAS

The two cycle engine used on this mini tiller/cultivator requires a mixture of gasoline and oil for lubrication of the bearings and other moving parts. The correct fuel mixture ratio is 24:1 (see Fuel Mixture Chart). Gasoline and oil must be premixed in a clean gasoline container. Always use fresh, clean unleaded gasoline.

WARNING: Experience indicates that alcohol blended fuels (called gasahol or using ethanol or methanol) can attract moisture which leads to separation and formation of acids during storage. Acidic gas can damage the fuel system of an engine while in storage. To avoid engine problems, the fuel system should be emptied before storage for 30 days or longer. Drain the gas tank, start

OPERATION

the engine and let it run until the fuel lines and carburetor are empty. Use fresh fuel next season. See **Storage Instructions** for additional information. Never use engine or carburetor cleaner products in the fuel tank or permanent damage may occur.

GASOLINE AND OIL MIXTURE

Mix gasoline and oil (See Fig. 7) as follows:

- Pour 1 U.S. quart of fresh, clean, unleaded automotive gasoline into a gallon gasoline container.
- Add (5 oz.) of clean, high quality SAE 30 or SAE 40 two-cycle oil into the gasoline container

IMPORTANT: DO NOT USE OUTBOARD MOTOR OIL OR MULTI-VISCOSITY OILS, SUCH AS 10W-30 OR 10W-40.

- Reinstall the cap on the gasoline container and shake container vigorously so the oil mixes with the gasoline.
- Add an additional 3 U.S. quarts of gasoline to the gallon container and shake the container again.

FUEL MIXTURE CHART (Mixture 24:1)

U. S.		S. I. (METRIC)	
GAS	OIL	GAS	OIL
1 Gal.	5 oz.	4 Liters	.167 L
2 Gal.	11 oz.	8 Liters	.333 L
5 Gal.	27 oz.	20 Liters	.833 L

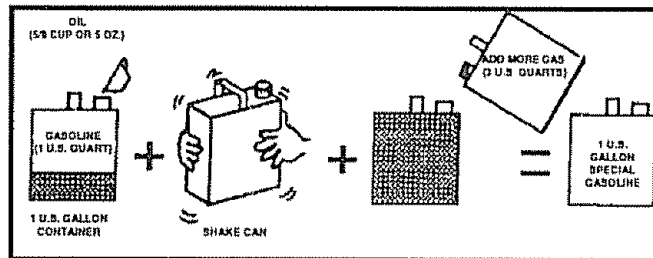

FIG. 7

- This completes the special gasoline mixing (24:1) procedure. It can now be poured into the mini tiller/cultivator fuel tank

IMPORTANT: DO NOT FILL FUEL TANK WITH GASOLINE THAT DOES NOT HAVE OIL MIXED IN IT. DO NOT USE GASOLINE ADDITIVES BECAUSE THE ENGINE MAY BE DAMAGED. SHAKE THE GASOLINE CONTAINER BEFORE EACH FILLING OF THE FUEL TANK

TO START THE ENGINE

Before starting the engine, be sure you have read and understood all the instructions on the preceding pages

- Fill the fuel tank (to 1/2 inch below the bottom of the fill neck) with fresh fuel mix and reinstall the fuel tank cap securely. Never use fuel that may be stale from long periods of storage.
- Move the shut-off switch to the ON position
- Move the choke control (see Fig. 6) to the FULL choke position (all the way down).

NOTE: A warm engine should not require choking



CAUTION: DO NOT TOUCH THE THROTTLE CONTROL WHILE STARTING THE ENGINE. THE MINI TILLER/CULTIVATOR WILL PROPEL ITSELF IF THE ENGINE SPEED IS ADVANCED FROM IDLE.

- Tilt the mini tiller/cultivator back on the depth stake or transport wheels to raise the tines off the ground
- Grasp the upper handle firmly to stabilize the mini tiller/cultivator and pull the starter handle with short quick pulls. Do not allow the starter handle to snap back, let it rewind slowly while holding the starter rope. It will take a few pulls on the starter handle to feed gas from the fuel tank to the carburetor
- When engine starts, move the choke control to 1/2 choke position until the engine runs smoothly. Then move choke control to OFF position
- If engine falters, move choke control to 1/2 choke position until engine runs smoothly. Then move choke control to OFF position
- If engine fires, but does not continue to run, move choke control to no choke position and repeat starting instructions

NOTE: If the tines do not stop when the throttle control is released, adjust the carburetor idle speed as instructed in **Step 5 of Carburetor Adjustment** paragraph in the **Service/Adjustments** section of this manual

- To stop the engine, release the throttle control and move the shut-off switch to the OFF position
- If the engine becomes flooded, see the **Spark Plug Maintenance** paragraph in the **Maintenance** section of this manual. Then pull the starter rope with the choke "OFF"



CAUTION: THE MUFFLER AND SURROUNDING AREAS BECOME HOT AFTER RUNNING THE ENGINE. AVOID THESE AREAS.

OPERATION

TILLING HINTS

- Tilling is digging in, turning over and breaking up packed soil before planting. Loose unpacked soil helps root growth. Best tilling depth is 4 to 6 inches. A tiller will also clear the soil of unwanted vegetation. The decomposition of this vegetation matter enriches the soil. Depending on the climate (rainfall and wind), it may be advisable to till the soil at the end of the growing season to further condition the soil.
- Avoid tilling the soil that is too dry as the soil pulverizes and produces a dust that will not hold water. Also, tilling soil that is too wet will produce unsatisfactory clods besides being hard on the machine.
- Better growth will be obtained in tilled ground if a relatively small area is tilled properly and the tilled ground used soon after tilling to preserve the moisture content.
- The depth stake (on the back of the mini tiller/cultivator) serves a dual purpose (see Fig 8). It helps regulate the depth of the cut to a uniform level and also acts as a brake to help the operator control the speed of the mini tiller/cultivator.
- Lowering the depth stake will slow the mini tiller/cultivator and make it till deeper. Raising the depth bar will allow the mini tiller/cultivator to move faster and till more shallow.
- If the tiller mini tiller/cultivator stops forward motion and tries to dig deeper than necessary, move the handles from side to side to start forward motion.

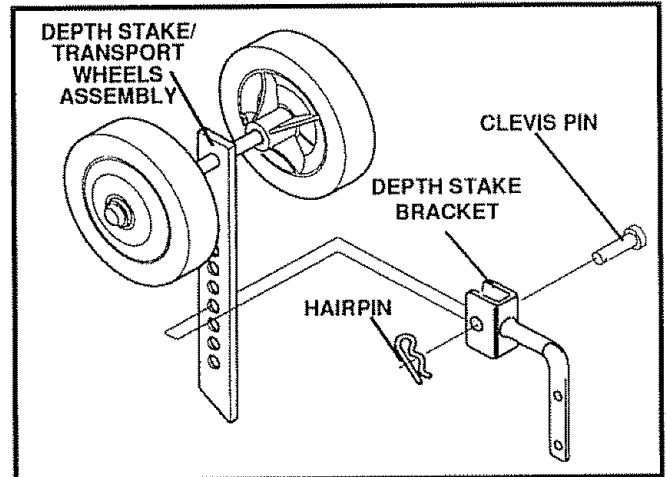

FIG. 8

CULTIVATING HINTS

- When cultivating (weed killing) it is best to till no deeper than 1-1/2 inches. Tilling deeper will only pull to the surface ungerminated weed seeds. You may want to raise the depth bar to lessen the braking action.
- When cultivating around plants or close areas you may want to remove the outside tines (see **Tine Replacement** paragraph in the **Service/Adjustments** section of this manual).

CUSTOMER RESPONSIBILITIES

SERVICE RECORDS Fill in dates as you complete regular service	SCHEDULE						SERVICE DATES			
	Before Each Use	After first 2 Hours	Every 25 Hours	Every 75 Hours	Before Storage	Before Each Season				
Tighten All Screws and Nuts	✓	✓								
Lubricate Transmission			✓			✓				
Lubricate Tine Shaft			✓		✓					
Clean and Re-Oil Air Cleaner Filter			✓		✓					
Check Spark Plug			✓		✓					
Cylinder Exhaust Ports				✓						
Drain Fuel					✓					

GENERAL RECOMMENDATIONS

The warranty on this mini tiller/cultivator does not cover items that have been subjected to operator abuse or negligence. To receive full value from the warranty, the operator must maintain the mini tiller/cultivator as instructed in this manual. The following **Service Recommendations Chart** is provided to assist the operator in properly maintaining the mini tiller/cultivator.

LUBRICATION

Every 25 hours and/or at the beginning of each season, the gear box should be filled with lubricant. Tubes of gear lubricant are available from most automotive supply stores. Use portable tool grease such as **Lubriplate 630AA** (Product No. 06787-1-3/4 oz. tube) or **Lubriplate GR-132** (Product No. 15892-10 oz. tube). The tine shaft should have oil applied before storage and after cleaning, if the mini tiller/cultivator is flushed with water. The following illustration is provided to assist the operator in properly maintaining the mini tiller/cultivator.

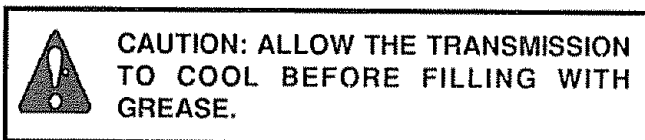

- Remove both left side tines (see **Adjustments/ Repairs** section) in this manual.
- Remove the air vent screw (see Fig 9) from the top left side of the transmission.
- Using a grease gun, fill the transmission through the grease fitting until the new grease begins to come out of the air vent screw hole.
- Reinstall the air vent screw.

- Check the condition of the felt washer in the side of the transmission at the tine shaft (see Fig 9). Replace the felt washer if it is damaged (see **Repair Parts** section in this manual)

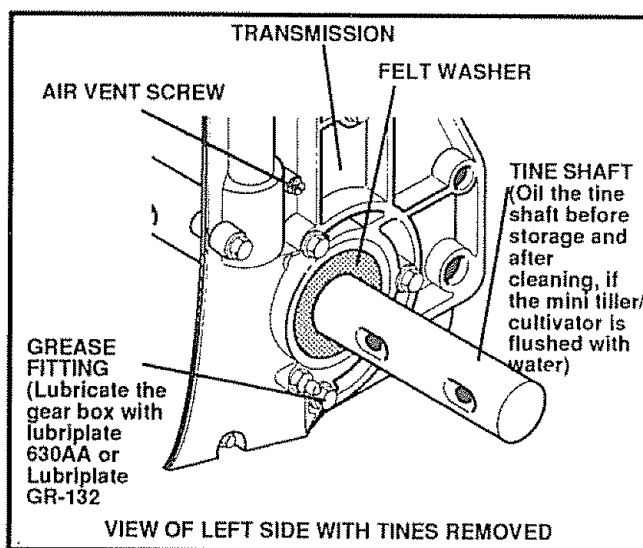

FIG. 9

- Clean tine shaft, spread a few drops of oil on shaft in tine replacement areas. Reinstall the tines
- Remove the right side tines. Check the felt washer for damage, clean and oil the tine shaft. Reinstall the tines.

CUSTOMER RESPONSIBILITIES

ENGINE

AIR CLEANER MAINTENANCE

The air cleaner filter should be cleaned and reoiled after every 25 hours of use. Clean more often under dusty conditions.

IMPORTANT: THE ENGINE CAN BE WORN OUT IN A VERY SHORT PERIOD OF TIME IF DIRT OR GRIT IS ALLOWED TO ENTER THE ENGINE.

To clean the air filter, do the following:

- Loosen screws on air cleaner cover (see Fig. 10) and remove the cover.
- Remove foam element from air cleaner
- Wipe inside of the air cleaner housing clean.
- Clean the foam element by washing in a strong solution of water and household detergent. Then rinse thoroughly in clean water.
- Wrap foam element in clean cloth and squeeze out (do not twist) all the liquid until dry.
- Cover the ends and side of the foam element with same oil used in fuel mixture. Knead the foam element between fingers to distribute oil and remove excess oil.
- Reinstall foam element in air cleaner housing.
- Service the foam element carefully, inspection for deterioration or damage. A defective, improperly serviced, or misassembled air filter will allow dirt particles to enter the engine.
- Reassemble the filter (see Fig. 10). Place the cover on the air cleaner housing and tighten screws to secure cover to the housing.



CAUTION: NEVER RUN THE ENGINE WITHOUT THE AIR CLEANER ELEMENT INSTALLED. A DEFECTIVE AIR CLEANER CAN RESULT IN LOSS OF ENGINE POWER AND CAN CAUSE EXCESSIVE WEAR OR DAMAGE TO THE ENGINE COMPONENTS IF DIRT OR DUST IS PERMITTED TO ENTER THE ENGINE THROUGH THE CARBURETOR. AN AIR CLEANER THAT IS CLOGGED WITH DUST OR DIRT SHOULD BE CLEANED AND RE-OILED.

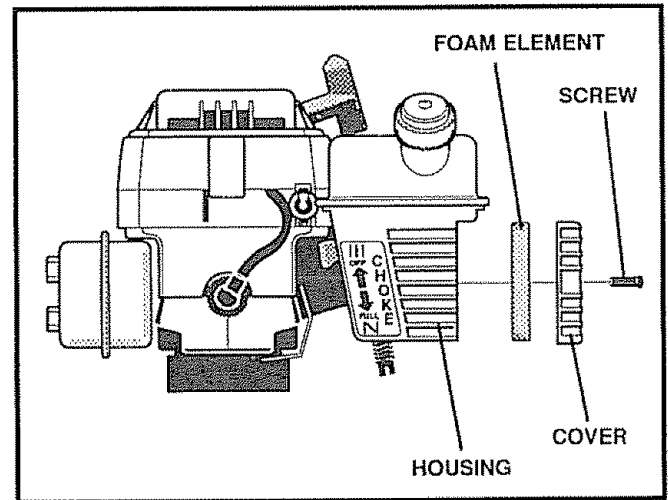

FIG. 10

SPARK PLUG MAINTENANCE

If the engine is flooded, clean the area around the spark plug base to prevent foreign material from entering the cylinders when the plug is removed. Remove and dry the spark plug. Regap the electrodes to .035 if necessary. If a new spark plug is needed, refer to the **Engine Operation and Maintenance** manual for the proper replacement spark plug. Tighten the spark plug firmly. If a torque wrench is available, torque the spark plug to 15 foot-pounds.

CYLINDER EXHAUST PORTS

The cylinder exhaust ports should be cleaned after each seventy-five (75) to one hundred (100) hours of operation. For this procedure we recommend that you take your unit to a technician trained to work on two cycle engines, such as a SEARS Service Center.

CUSTOMER RESPONSIBILITIES

CLEANING

Always remove the dirt and debris from the mini tiller/cultivator after each use (see Fig. 11). Remove any string, wire or vegetation that may become lodged in the mechanism and stop the tine rotation. Proceed as follows:

- Release the throttle control and move the shut-off switch to the OFF position, then disconnect the spark plug wire.
- Remove the hairpin and clevis pin securing the tine(s) assembly to the shaft and remove the tine(s) (see Fig. 11).
- Remove the lodged material. Reassemble the tine(s) on the shaft and secure with a clevis pin and hairpin.
- Reconnect the spark plug wire and restart the engine.

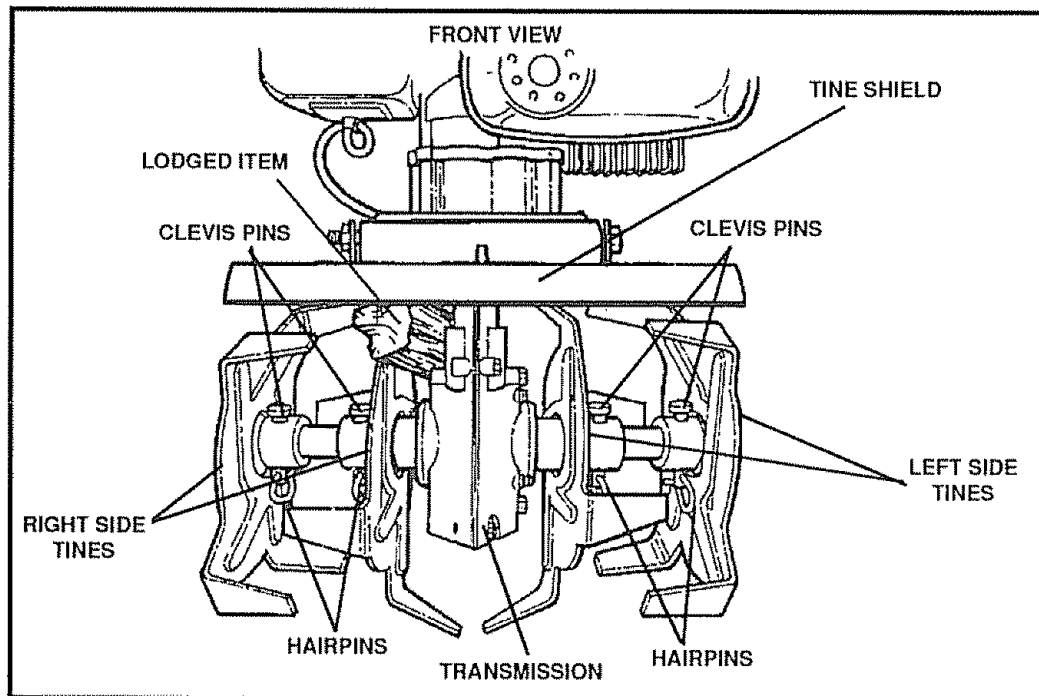

FIG. 11

SERVICE AND ADJUSTMENTS

TINE REPLACEMENT

The mini tiller/cultivator is left hand or right hand as viewed from the operator's position behind the unit.

All four tines on this unit are different and cannot be interchanged. The tines must be properly installed as shown in figures 12 and 13 or the mini tiller/cultivator will not function properly.

The outside tines may be removed to reduce the tilling width to about 7 inches, for working close around plants or in small areas, if desired. When reinstalling the outside tines see below.



CAUTION: THE TINES ARE SELF-SHARPENING AND WILL BECOME QUITE SHARP FROM USE. HANDLE CAREFULLY.

The tines will all wear fairly evenly. If the tines are being replaced because of wear, we recommend that all four tines be replaced at the same time. To replace the tines, do the following:

- Place the shut-off switch to the OFF position and disconnect the spark plug wire.
- Remove the hairpins and the clevis pins from the tines on one side of the unit and remove the tines.
- Clean the tine shaft and oil the shaft at the tine locations.
- Place the inside tine on the tine shaft and reinstall the clevis pin and hairpin.
- When the tines are properly installed, the letter "R" will be visible on the outside of the right-hand tine (the letter "L" on the left-hand tine). The letter should appear opposite the small hole in the side of the tine.
- Place the outside tine on the tine shaft and reinstall the clevis pin and hairpin cotter.
- The outside tine cutting tips will all bend in toward the inside tine. The letter "R" on the right side or "L" on the left side should be visible from the outside of the unit.
- Repeat steps on the opposite side of the unit.
- Check to make sure the tines are installed on correct side of the unit.

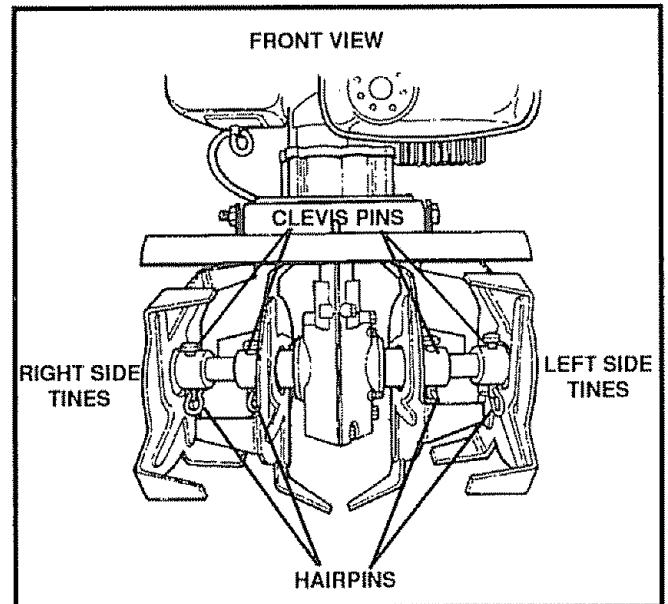

FIG. 12

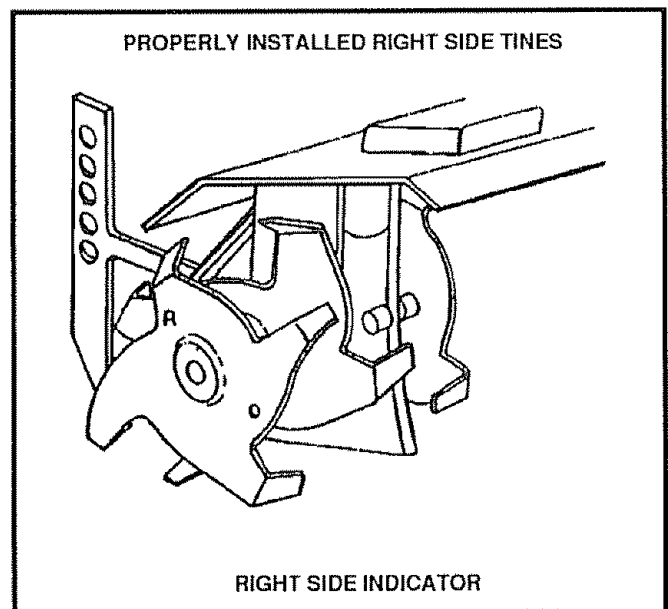

FIG. 13

SERVICE AND ADJUSTMENTS

CARBURETOR ADJUSTMENT

A dirty air cleaner will cause the engine to run improperly and/or smoke excessively. Be sure the air cleaner is clean before adjusting the carburetor. Never make unnecessary adjustments to the carburetor. The carburetor was set at the factory to operate efficiently under most applications. However, if adjustments are required, we recommend you contact your nearest SEARS Service Center. If you feel that you are competent to make carburetor adjustment proceed as follows:



CAUTION: USE EXTREME CARE WHEN MAKING ADJUSTMENTS THAT REQUIRE THE ENGINE TO BE RUNNING. KEEP HANDS, FEET, HAIR AND LOOSE CLOTHING AWAY FROM ANY MOVING PART.

- Turn the mixture adjustment screw (see Fig. 14) clockwise to close.

IMPORTANT: TIGHTEN THE ADJUSTING SCREW WITH YOUR FINGERS TO PREVENT DAMAGE TO THE CARBURETOR OR ADJUSTING SCREW.

- Turn the mixture screw counterclockwise (open) one (1) turn.
- Start the engine and let it warm up approximately 3 to 5 minutes. Do not adjust the carburetor when the engine is cold.
- If the engine falters or stops after the choke lever is moved to the OFF position, open the mixture adjusting screw an additional 1/8 turn counterclockwise
- With the engine running, release the throttle control (idle position) to make the mixture adjustments
 - a. Turn the mixture adjusting screw (see Fig. 14) slowly clockwise until the engine falters. Note this location.
 - b. Turn the mixture adjusting screw slowly counterclockwise until the engine starts to sputter. Note this location.
 - c. Turn the mixture adjusting screw clockwise until it is halfway between the first position where the engine faltered and the second position where the engine started to sputter.

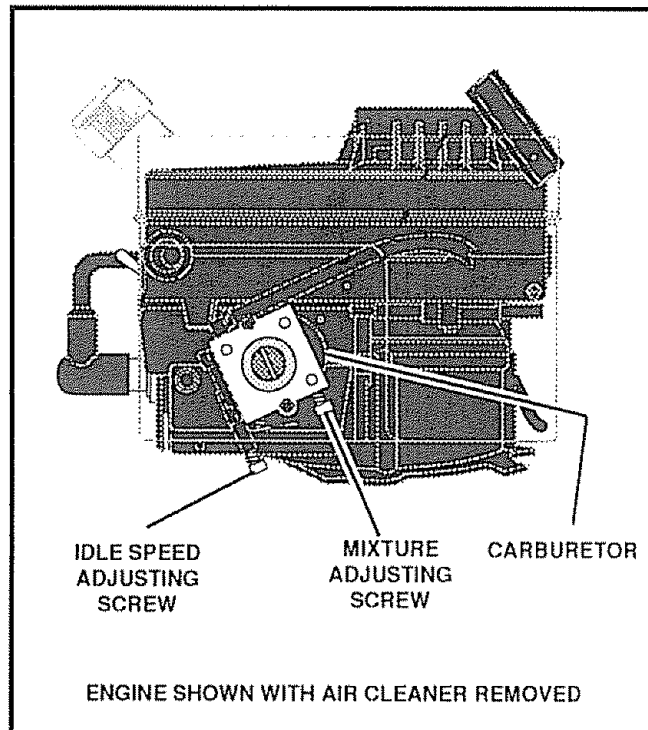

CAUTION: NEVER TAMPER WITH THE ENGINE GOVERNOR WHICH IS FACTORY SET FOR PROPER ENGINE SPEED. OVER-SPEEDING THE ENGINE ABOVE THE FACTORY HIGH SPEED SETTING CAN BE DANGEROUS. IF YOU THINK THE ENGINE GOVERNED HIGH SPEEDS NEEDS ADJUSTING, CONTACT YOUR NEAREST SEARS SERVICE CENTER WHICH HAS THE PROPER EQUIPMENT AND EXPERIENCE TO MAKE ANY NECESSARY ADJUSTMENTS.

- The idle speed may need to be adjusted after making the mixture adjustment. If the tines do not turn when the engine is running and the throttle control is released, the idle speed will not need adjusting. If the tines turn when the throttle control is released, do the following:
 - a. Have someone hold the mini tiller/cultivator back on the depth bar with the tines off the ground
 - b. Start the engine
 - c. With the throttle in the released (idle) position, turn the idle speed adjusting screw counterclockwise until the tines stop rotating

STORAGE



CAUTION: NEVER STORE ENGINE WITH FUEL IN TANK INDOORS OR IN ENCLOSED, POORLY VENTILATED AREA, WHERE FUEL FUMES MAY REACH AN OPEN FLAME, SPARK OR PILOT LIGHT AS ON A FURNACE, WATER HEATER, CLOTHES DRYER, ETC.

NOTE: The tiller/mini tiller/cultivator should be immediately prepared for storage at the end of the season or if the unit

will not be used for 30 days or more.

MINI TILLER/CULTIVATOR

- Thoroughly clean the mini tiller/cultivator. Remove all dirt and debris from the engine and unit.
- Remove the tines and oil the tine shaft and reinstall the tines (see **Service/Adjustments** section in this manual).
- Loosen the tee knobs that secure the upper handle to the lower handle.
- Carefully fold the upper handle down making sure the throttle is not kinked. Tighten the tee knobs.
- The cross piece of the upper handle (between the lower handles) can now be used as a carry handle or can be hooked over a wall hook to store the mini tiller/cultivator up off the floor out of the way.

NOTE: A yearly checkup or tuneup by a SEARS Service Center is a good way to insure that your mini tiller/cultivator will provide maximum performance for the next season.

ENGINE

IMPORTANT: IT IS IMPORTANT TO PREVENT GUM DEPOSITS FROM FORMING IN ESSENTIAL FUEL SYSTEM PARTS SUCH AS THE CARBURETOR, FUEL FILTER, FUEL HOSE OR TANK DURING STORAGE. ALSO, EXPERIENCE INDICATES THAT ALCOHOL BLENDED FUELS (CALLED GASOHOL OR USING ETHANOL OR METHANOL) CAN ATTRACT MOISTURE WHICH LEADS TO SEPARATION AND FORMATION OF ACIDS DURING STORAGE. ACIDIC GAS CAN DAMAGE THE FUEL SYSTEM OF AN ENGINE WHILE IN STORAGE.

- Drain the fuel from the fuel tank into an approved container outdoors, away from open flame.
- Start and run the engine until it stops due to lack of fuel.
- Pull the starter handle slowly until you feel resistance due to compression pressure, then stop.
- Release the starter tension slowly to prevent the engine from reversing due to compression pressure. This position will close both the intake and exhaust ports to prevent corrosion of the piston and cylinder bore.

OTHER

- If possible, store your mini tiller/cultivator indoors and cover it to give protection from dust and dirt.
- Cover the mini tiller/cultivator with a suitable protective cover that does not retain moisture. Do not use plastic.

IMPORTANT: NEVER COVER THE MINI TILLER/CULTIVATOR WHILE THE ENGINE AND EXHAUST AREAS ARE STILL WARM.

TROUBLE SHOOTING

TROUBLE	CAUSE	CORRECTION
Difficult starting	Stale fuel mixture	Drain fuel tank. Fill with fresh mixture.
	Too much oil in mixture	Check fuel mix chart and mix fresh fuel.
Engine runs erratically	Dirt in fuel tank or out of fuel	Clean fuel tank. Fuel tank should be half full when starting engine.
Engine will not run at full speed	Carburetor out of adjustment	See carburetor adjustment section.
	Fouled spark plug	Clean and re-gap plug
	Plugged air cleaner	Clean and re-oil air cleaner.
Engine speed does not increase properly	Debris interfering with throttle linkage	Blow dirt and debris off top of carburetor.
Engine smokes excessively	Plugged air cleaner	Clean and re-oil air cleaner.
	Too much oil in fuel mixture	Check fuel mix chart and mix fresh fuel.
Tines continue to rotate when throttle the control is released	Carburetor out of adjustment	Adjust carburetor idle speed. See Carburetor Adjustment paragraph in Service/Adjustments section of this manual.
Tines will not turn	Foreign object lodged in tine	Remove lodged item. See Keep Tiller/Cutliver Clean paragraph in the Operation section of this manual.
Unit does not till properly	Incorrect tine installation	Check the tines for proper installation. See the Tine Replacement paragraph in the Service/Adjustment section of this manual.

SEARS

OWNER'S MANUAL

MODEL NO. 536.797500

HOW TO ORDER REPAIR PARTS

CRAFTSMAN®

32.8cc 2-CYCLE 10 INCH DIAMETER TINERS MINI TILLER/CULTIVATOR

Each CULTIVATOR has its own MODEL NUMBER found on the tine shield.

Each ENGINE has its own MODEL NUMBER found on the BLOWER HOUSING.

Always mention these MODEL NUMBERS when requesting service or Repair Parts for your CULTIVATOR.

All parts may be ordered through any Sears, Roebuck and Company Service Centers and most Retail Stores.

**WHEN ORDERING REPAIR PARTS, ALWAYS
GIVE THE FOLLOWING INFORMATION:**

- * PRODUCT - MINI TILLER/CULTIVATOR
- * MODEL NUMBER - 536.797500
- * ENGINE MODEL NUMBER - 143.941600
- * PART NUMBER
- * PART DESCRIPTION

"Your Sears merchandise has added value when you consider that Sears has service units nationwide staffed with Sears trained technicians... Professional technicians specifically trained on Sears Products, having the parts, tools and equipment to insure that we meet our pledge to you...we service what we sell."

SEARS, ROEBUCK AND CO., Hoffman Estates, IL 60179 USA

331518 12/01/93

Printed in U.S.A.