

INSTRUCTIONS

CAUTION

INSPECT CONTENTS IMMEDIATELY AND FILE CLAIM WITH DELIVERING CARRIER FOR ANY DAMAGE.
SAVE YOUR BOX AND ALL PACKING MATERIALS.
YOU ARE RESPONSIBLE FOR DAMAGE TO YOUR UNIT IF RETURNED IMPROPERLY PACKED.

IMPORTANT!

- **Local Code** - You are required to consult the local building and plumbing codes prior to installation. If information given here is inconsistent with local building or plumbing code, the local codes should be followed.
- **Testing** - The backflow preventer must be tested periodically in compliance with local codes, but at least once per year. For field testing procedures, refer to Watts instruction sheets: IS-TK-DP/DL, IS-TK-9A, IS-TK-99E, and IS-TK-99D found on www.watts.com.
- **Indoors** - The backflow preventer assembly must be easily accessible to facilitate testing and servicing. If it is located in a line close to a wall, be sure the test cocks are easily accessible.
In normal operation, there will be a slight discharge of water. A drain line and air gap should be piped from the relief valve connection, where evidence of discharge will be clearly visible so that water damage will not occur.
NEVER INSTALL IN CONCEALED LOCATIONS.

Tempering Water Temperature Floor Grate Detail

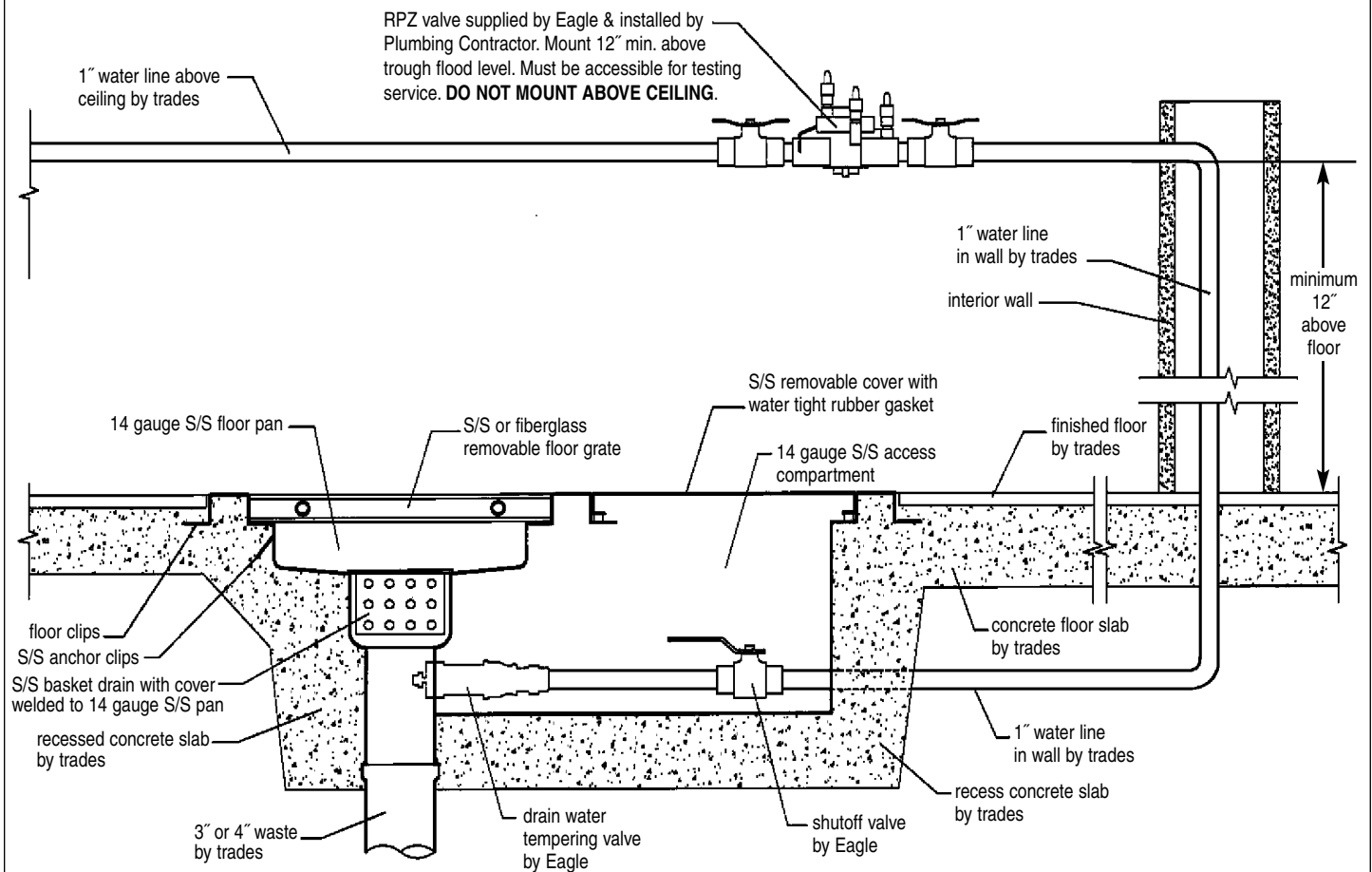

(continued on next page)

EG9899 Revised 08/17

Cool Trough®

INSTRUCTIONS

Top View

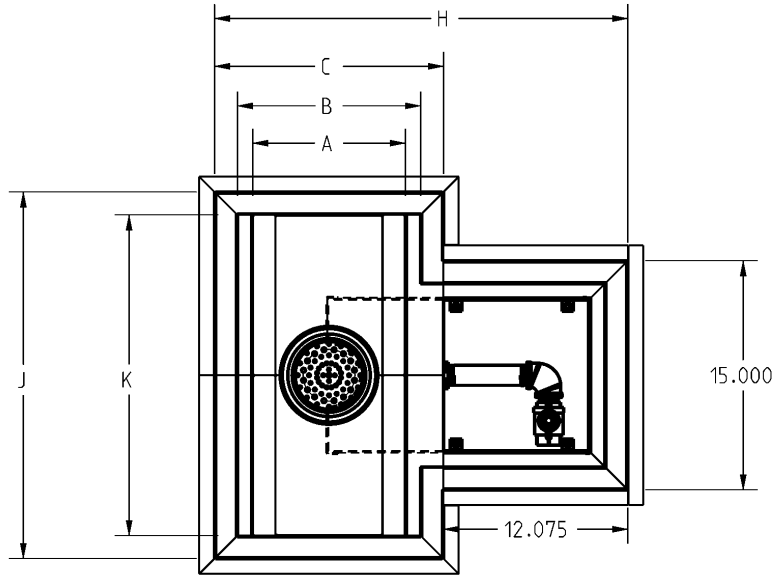

Bottom View

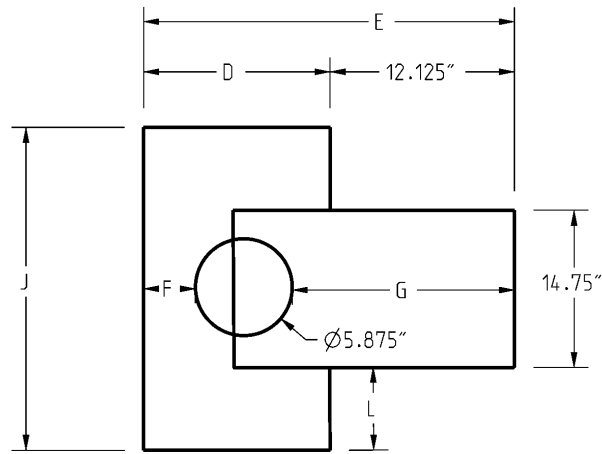

Widths — See next page for Lengths.

MODEL	12" WIDE	15" WIDE	18" WIDE	24" WIDE
A = 7"	A = 10"	A = 13"	A = 19"	
B = 9"	B = 12"	B = 15"	B = 21"	
C = 12"	C = 15"	C = 18"	C = 24"	
D = 9.25"	D = 12.25"	D = 15.25"	D = 21.25"	
E = 21.375"	E = 24.375"	E = 27.375"	E = 33.375"	
F = 1.688"	F = 3.188"	F = 4.688"	F = 7.688"	
G = 13.763"	G = 15.263"	G = 16.763"	G = 19.763"	
H = 24.075"	H = 27.075"	H = 30.075"	H = 36.075"	

(continued on next page)



Cool Trough®

INSTRUCTIONS

End View of Cool Trough®

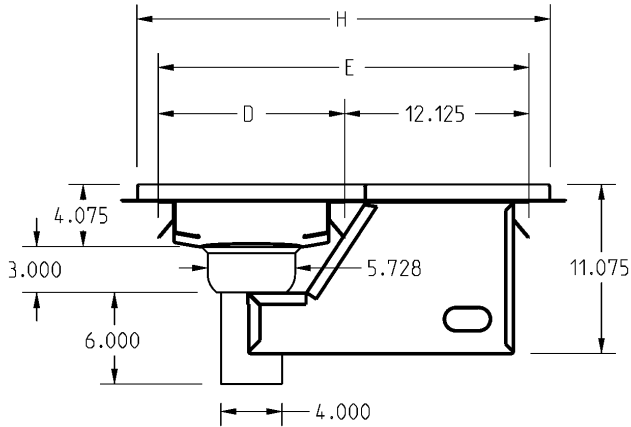

Front View of Cool Trough®

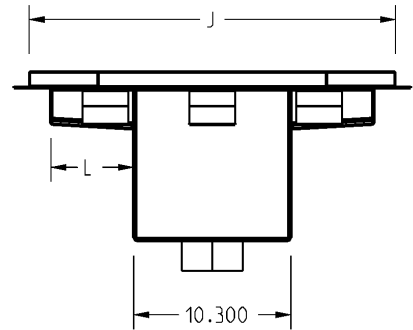

End View of Rough-In

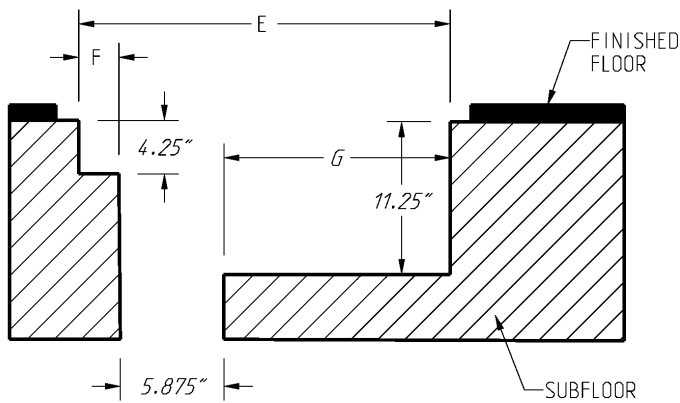

Front View of Rough-In

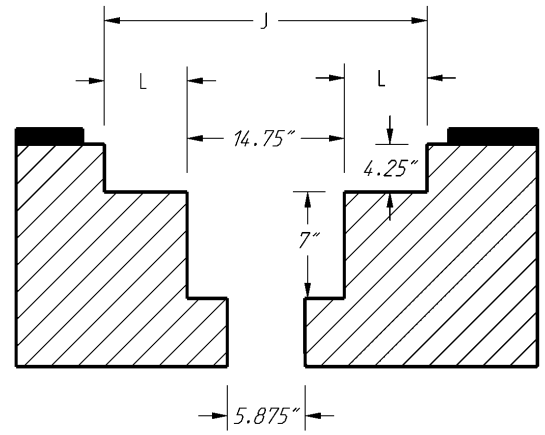

Lengths — See previous page for Widths.

MODEL	15" LONG	18" LONG	24" LONG	30" LONG	36" LONG	48" LONG	60" LONG	72" LONG	84" LONG	96" LONG	120" LONG
J = 15"	J = 18"	J = 24"	J = 30"	J = 36"	J = 48"	J = 60"	J = 72"	J = 84"	J = 96"	J = 120"	
K = 12"	K = 15"	K = 21"	K = 27"	K = 33"	K = 45"	K = 57"	K = 69"	K = 81"	K = 93"	K = 117"	
L = 0"	L = 1.625"	L = 4.625"	L = 7.625"	L = 10.625"	L = 16.625"	L = 22.625"	L = 28.625"	L = 34.625"	L = 40.625"	L = 52.625"	

Size of rough-in hole for trough should be as follows:
 Width = "Dimension D"
 Length = "Dimension J"
 Depth = 4.25"

Size of rough-in for the plumbing compartment should be as follows:
 Width = "Dimension E", use Dimensions F & G for placement.
 Length = 14.75", use Dimension L for placement.
 Depth = 11.25"

(continued on back page)



Cool Trough®

INSTRUCTIONS

Isometric View of Rough-In

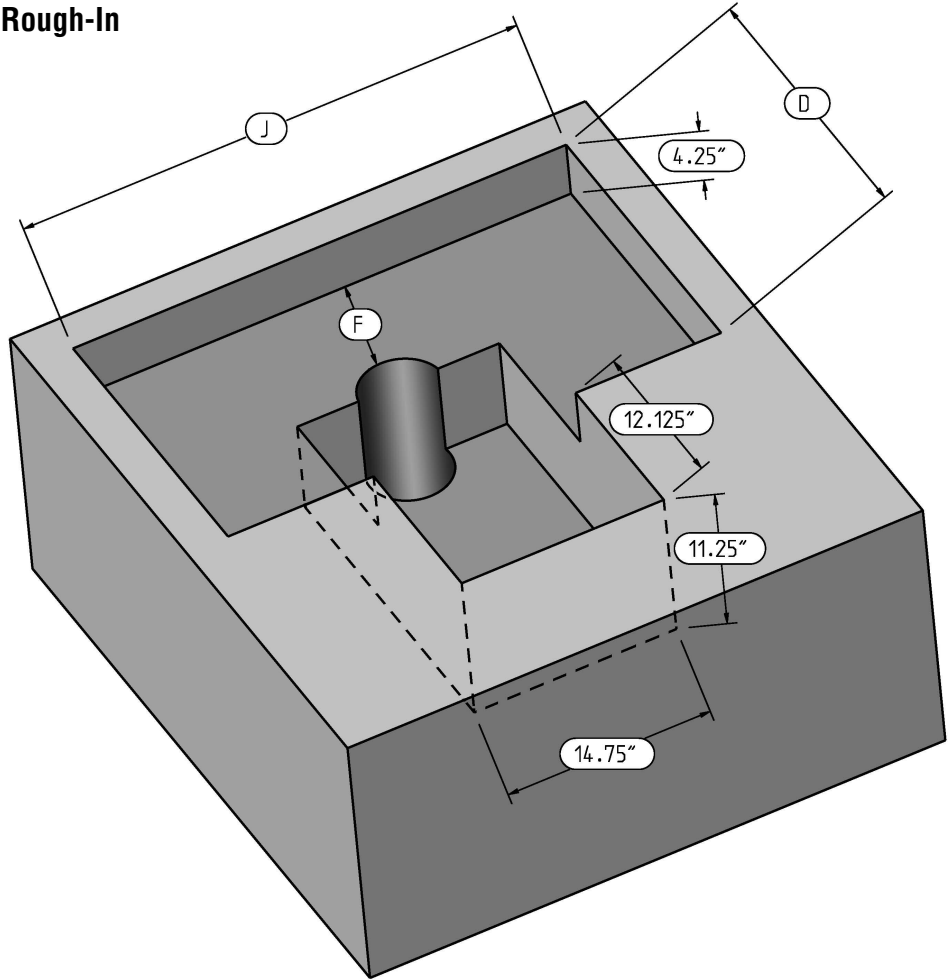

Widths

MODEL			
12" WIDE	15" WIDE	18" WIDE	24" WIDE
D = 9.25"	D = 12.25"	D = 15.25"	D = 21.25"
F = 1.688"	F = 3.188"	F = 4.688"	F = 7.688"

Lengths

MODEL										
15" LONG	18" LONG	24" LONG	30" LONG	36" LONG	48" LONG	60" LONG	72" LONG	84" LONG	96" LONG	120" LONG
J = 15"	J = 18"	J = 24"	J = 30"	J = 36"	J = 48"	J = 60"	J = 72"	J = 84"	J = 96"	J = 120"

(End)



• 100 Industrial Boulevard, Clayton, Delaware 19938-8903 U.S.A. • www.eaglegrp.com
 • Phone: 302/653-3000 • (Foodservice) 800/441-8440 • (MHC/Retail) 800/637-5100
 • Fax: 302/653-2065

