



IMPORTANT FOR FUTURE REFERENCE Please complete this information and retain this manual for the life of the equipment:
Model #: _____
Serial #: _____
Date Purchased: _____

Installation & Operation Manual

Gas Fired Steamers GSX-10HE & GSX-16HE



Model GSX-10HE

WARNING

Improper installation, adjustment, alteration, service or maintenance can cause property damage, injury or death. Read the installation, operating and maintenance instructions thoroughly before installing or servicing this equipment.

CROWN FOOD SERVICE EQUIPMENT

 A Middleby Company

70 Oakdale Road, Downsview (Toronto) Ontario, Canada, M3N 1V9

Telephone: 919-762-1000



www.crownsteamgroup.com



SAFETY PRECAUTIONS

Before installing and operating this equipment, be sure everyone involved in its operation is fully trained and aware of precautions. Accidents and problems can be caused by failure to follow fundamental rules and precautions.

The following symbols, found throughout this manual, alert you to potentially dangerous conditions to the operator, service personnel, or to the equipment.

 DANGER	This symbol warns of immediate hazards that will result in severe injury or death.
 WARNING	This symbol refers to a potential hazard or unsafe practice that could result in injury or death.
 CAUTION	This symbol refers to a potential hazard or unsafe practice that could result in injury, product damage, or property damage.
NOTICE	This symbol refers to information that needs special attention or must be fully understood, even though not dangerous.

IMPORTANT NOTES FOR INSTALLATION AND OPERATION

WARNING

This is the safety alert symbol. It is used to alert you to potential personal injury hazards. Obey all safety messages that follow this symbol to avoid possible injury or death.

WARNING

FOR YOUR SAFETY:

Do not store or use gasoline or other flammable vapors or liquids in the vicinity of this or any other appliance.

WARNING

Improper installation, operation, adjustment, alteration, service or maintenance can cause property damage, injury or death. Read the installation, operating and maintenance instructions thoroughly before installing, operating or servicing this equipment.

NOTICE

This product is intended for commercial use only. NOT FOR HOUSEHOLD USE.

NOTICE

This manual should be retained for future reference.

PURCHASER: Instructions to be followed in the event the operator of this appliance smells gas must be posted in a prominent location. This information shall be obtained by consulting the local gas supplier.

Do not attempt to operate this unit in the event of power failure.

Keep the appliance area free and clear from combustibles.

DO NOT obstruct the flow of combustion and ventilation air.

Adequate clearances **MUST** be maintained for servicing and proper operation.

Contact the factory, the factory representative or a local service company to perform maintenance and repairs should the appliance malfunction. Refer to warranty terms.

RETAIN THIS MANUAL FOR FUTURE REFERENCE.

Table of Contents

Important Notes For Installation and Operation	2
Service Connections	4
Installation Instructions	7
Performance Check	9
Operation	10
Maintenance	13
Cooking Guidelines.....	12
Troubleshooting	15

SERVICE CONNECTIONS

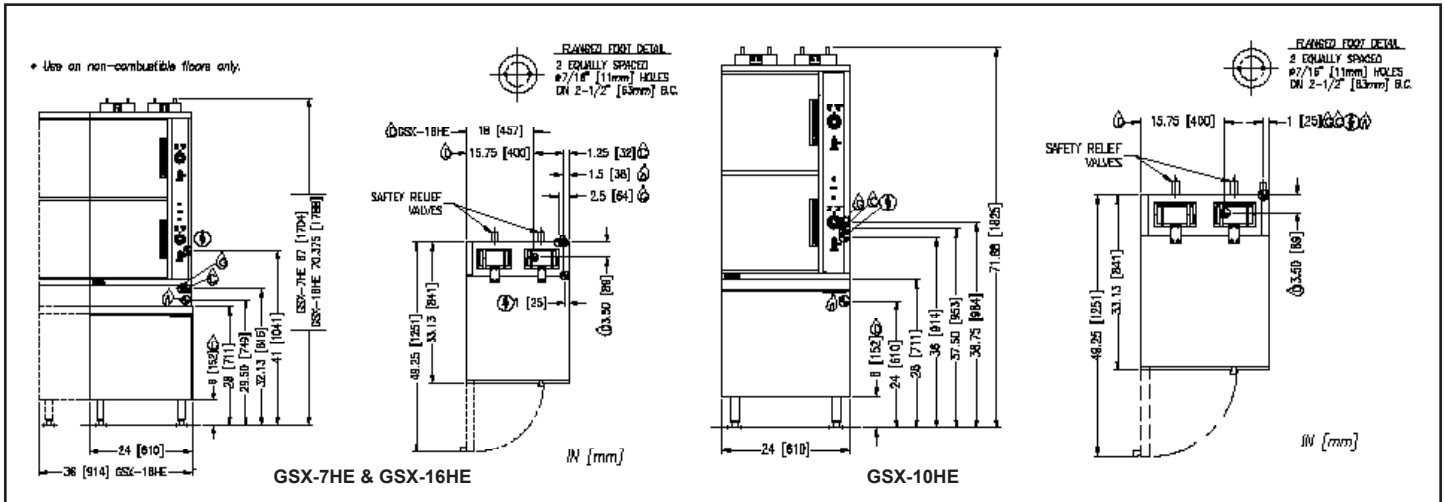

SERVICE CONNECTIONS

- ELECTRICAL CONNECTION: Unless otherwise specified, Electrical Connection to be 120 Volts, 6. Hertz single phase with ground. Furnished with 6 foot cord with 3 prong plug. Maximum 4.0 amps.
- DRAIN: 2" (51 mm) IPS piped to open floor drain. No solid connection.
- GAS CONNECTION: 3/4" IPS supply line required.
- CONDENSATE COLD WATER: 3/8" O.D. tubing at 25-50 PSI (170-345 kPa)
- BOILER FEED WATER: 3/8" O.D. tubing at 25-50 PSI (170-345 kPa).

GAS CHARACTERISTICS

MODEL	GAS SUPPLY PRESSURE			
	BTU/HR.	kW/HR.	NATURAL	PROPANE
GSX-10HE	190,000	56	6"-14" (152-356mm)	12"-14" (305-356mm)
GSX-16HE	190,000	56	6"-14" (152-356mm)	12"-14" (305-356mm)

SPECIFICATIONS

Model	Compartments	Capacity	SHIPPING WT	CLEARANCE	
GSX-10HE	2	1-10 Pans (2-1/2")	700lbs (318kg)	SIDES	0
GSX-16HE	2	1-16 Pans (2-1/2")	900lbs (408kg)	BACK	6 [152]

WATER QUALITY STATEMENT

Water is the essential ingredient in steam equipment, water quality is the major factor affecting the performance of your appliance. Crown Steam Group offers a Comprehensive Water Treatment System which exceeds our minimum water requirements. Proof of installation and proper cartridges replacement is required for warranty coverage. Water supply to Crown Steam Group steamers must be within these guidelines.

Total dissolved solids	Less than 60 PPM	Chlorine	Less than 1.5 PPM
Total alkalinity	Less than 20 PPM	pH Factor	6.8 - 7.3
Silica	Less than 13 PPM		

Water which does not meet these standards should be treated with the installation of Middleby's Water Treatment System. Call 919-762-1000 if you have questions concerning your water meeting these parameters.

*Failure or malfunction of this appliance due to poor water quality is not covered under warranty.
Reference www.crownsteamgroup.com for complete warranty details and instructions.

INSTALLATION INSTRUCTIONS

UNPACKING

IMMEDIATELY INSPECT FOR SHIPPING DAMAGE

Immediately after unpacking the steamer, check for possible shipping damage. If the steamer is found to be damaged, save the packaging material and contact the carrier within 15 days of delivery.

Prior to installation, verify that the electrical service agrees with the specifications on the machine data plate which is located on the left side panel.

WARNING

Do not connect the appliance to the electrical supply until after the gas connection has been made.

Installation must conform to local codes, or in absence of local codes, with the National Fuel Gas Code - ANSI Z223.1/ NFPA 54, or the Natural Gas and Propane Installation Code, CSA B149.1, as applicable.

1. The appliance and its individual shut off valve must be disconnected from the gas supply piping system during any pressure testing of that system at pressures in excess of 1/2 psi (3.5 kPa).
2. The appliance must be isolated from the gas supply piping system by closing its individual manual shut off valve during any pressure testing of the gas supply piping system at test pressures equal to or less than 1/2 psi (3.5 kPa).

Electrical grounding must be provided in accordance with local codes, or in the absence of local codes, with the National Electrical Code ANSI/NFPA 70, or the Canadian Electrical Code, CSA C22.2, as applicable.

Ventilation must be provided in accordance with local codes, or in the absence of local codes, with ANSI/NFPA 96 Standard for Ventilation and Fire Protection of Commercial Cooking Operations.

WARNING

ELECTRICAL GROUNDING INSTRUCTIONS

This appliance is equipped with a three-prong (grounding) plug for your protection against shock hazard and should be plugged directly into a properly grounded three-prong receptacle. Do not cut or remove the grounding prong from this plug. (120V units only).

WIRING DIAGRAM FOR APPLIANCE IS LOCATED ON RIGHT HAND SIDE PANEL OF THE COOKER CABINET.

EXHAUST FANS AND Canopies

Canopies are set over ranges, ovens, kettles, etc., for ventilation purposes. It is recommended that a canopy extend 6" past the appliance and be located 6' 6" from the floor. Filters should be installed at an angle of 45 degrees or more with the horizontal. This position prevents dripping of grease and facilitates collecting the run-off grease in a drip pan, usually installed with the filter. A strong exhaust fan tends to create a vacuum in the room and may interfere with burner performance or may extinguish pilot flames. Makeup air openings approximately equal to the fan area will relieve such vacuum. In case of unsatisfactory performance on any appliance, check with the exhaust fan in the "OFF" position.

WALL EXHAUST FAN

The exhaust fan should be installed at least two feet above the vent opening at the top of the unit.

CLEARANCES

Adequate clearance must be provided in aisle and at the side and back. Adequate clearances for air openings into the combustion chamber must be provided, as well as for serviceability for use on noncombustible floors. Minimum clearance from combustible and noncombustible construction, 0" on left side, 0" on right side and 6" from back.

 **WARNING**

These procedures must be followed by qualified personnel or warranty will be voided.

To Install

1. Uncrate carefully. Report any freight damage to the freight company immediately.
2. Set the unit in place. Be certain to maintain the minimum clearances from combustibles and non-combustibles.
3. For an appliance supplied with legs, level the appliance using a spirit level. Should flanged adjustable feet be provided, anchor to floor using proper anchoring devices.
4. Seal bolts and flanged feet with Silastic or other equivalent compound.
5. Be certain to leave adequate clearances for cleaning, maintenance and service.

 **WARNING**

For an appliance equipped with casters, the installation shall be made with a connector that complies with the standard for connectors for moveable gas appliances, ANSI Z21.69-CSA 6.16 and a quick-disconnect device that complies with the standard for quickdisconnect devices for use with gas fuel, ANSI Z21.41-CSA 6.9; adequate means must be provided to limit the movement of the appliance without depending on the connector and the quickdisconnect device or its associated piping to limit the appliance movement; the location where the restraining means may be attached to the appliance is on bottom of unit directly below relief valve.

If the unit is also equipped with an optional water fill valve it too must be installed with a flexible water supply tube, a quick disconnect and strain relief.

GAS CONNECTIONS

CAUTION

The pipe thread compound used when installing pipes must be a type that is resistant to the action of liquified petroleum or propane gases.

NOTICE

If this equipment is being installed at over 2,000 feet altitude and was not so specified on order, contact service department. Failure to install with proper orifice sizing may void the warranty.

1. The Serial and Rating Plate on the unit indicates the type of gas your unit is equipped to burn. DO NOT connect to any other gas type.
2. A 3/4" NPT line is provided at rear for the connection. Each compartment is equipped with an internal pressure regulator which is set at 3.5" W.C. manifold pressure for natural gas and 10" W.C. for propane gas. Use 1/8" pipe tap on the burner manifold for checking pressure.

An adequate gas supply is imperative. Undersized or low pressure lines will restrict the volume of gas required for satisfactory performance. A steady supply pressure, between 6" W.C. and 14" W.C. for natural gas and 12" W.C. and 14" W.C. for propane gas is recommended. With all units operating simultaneously, the manifold pressure on all units should not show any appreciable drop. Fluctuations of more than 25% on natural gas and 10% on propane gas will create problems, affecting burner operation. Contact your gas company for correct supply line sizes.

Purge the supply line to clean out any dust, dirt or other foreign matter before connecting the line to the unit. Use pipe joint compound which is suitable for use with Liquid Propane on all threaded connections.

Test pipe connections thoroughly for gas leaks.

WARNING

Never use an open flame to check for gas leaks. Check all connections for leaks using soapy water before use.

ELECTRICAL CONNECTION

120 VAC-60 Hz - Single Phase

Units with this electrical rating are factory supplied with a three-wire cord and three-prong plug which fits any standard 120V, three-prong grounded receptacle. A separate 15 amp supply is needed for each unit.

PLUMBING CONNECTIONS

NOTICE

The steamer drain (2" IPS) should be piped to a floor drain near the back of the steamer (NOT directly under the steamer and NOT near front of the steamer).

There should be no solid drain connection; an "open gap" between the steamer and the floor drain is required.

COLD WATER CONDENSER

The steamer is equipped with a cold water condenser, in the rear of the cooking chamber, which helps to condense the steam prior to discharge into the drain. The steamer freely vents itself by the negative pressure created by the condensate water drainage. This negative pressure prevents steam leakage around the door gasket and helps draw the steam through the cooking compartment. Steam leakage at the door may indicate a plugged or improperly installed drain.

Temperature of condensate water flowing through the drain is controlled by the Thermostatic Cooling Valve (TCV) located inside the controls compartment on the right side of the unit. The valve has been factory set to keep condensate water flowing into the drain at or below 140°F. Depending on local plumbing code requirements, this setting may be changed to obtain a different maximum drainage temperature. Refer to next section Performance Check for instructions to set the (TCV).

WATER CONDITIONING

It is important that the water supplied to the generator be softened to no more than 2.0 grains of hardness and have a pH of 6 to 7.5. This degree of hardness can be easily obtained with the use of a properly maintained water softener. The use of a water meter will determine the water consumption and when the water softener needs regeneration or recharging. Failure to comply with these water condition standards may void the warranty.

Untreated water contains scale producing minerals which can precipitate onto the surfaces in the steam generator. Due to the temperatures in the steam generator, the minerals can bake onto the surfaces and components. This can result in early component failure and reduced product life. Water level probes become coated with scale. Scale may bridge across the probe insulator from the metal extension which senses the water level in the steam generator shell. Once this scale becomes wet, the water level control is unable to maintain the proper water level in the steam generator.

STRAINERS and FILTERS will NOT remove minerals from the water.

PERFORMANCE CHECK

 **CAUTION**

The appliance and its parts are hot. Use care when operating, cleaning and servicing the appliance.

Once the steamer is installed and all mechanical connections have been made, thoroughly test the steamer before operation.

1. Check that proper water, drain and electrical and gas connections have been made.
2. Turn main power switch ON.
3. Check that “Ignition” light comes on when the pilot burner is on.
4. After approximately 15 minutes, the “READY” light should come on, indicating that the water temperature is 205° Fahrenheit (97° Celsius). When the “READY” light comes on, set timer to the “5 minute” position. With door open, observe that no steam is entering the compartment and that the “COOKING” light is OFF.
5. Close compartment door. The COOKING light should now illuminate and steam should be heard entering the compartment after about 45 seconds.
6. After five minutes of operation check drain line to ensure that water from the cold water condenser is flowing through the drain line.
7. Open compartment door and observe that steam supply to chamber is cut off. “READY” light should again come on as “COOKING” light turns “OFF”.
8. Close compartment door and let cooking cycle finish. When the timer returns to “0” position, a buzzer will sound signaling the end of the cooking cycle. Buzzer must be manually turned off by setting the timer to its “OFF” position.
9. With all compartments of the steamer operating in the cooking cycle, check the temperature of the condensate coming out the drain. If the drain temperature exceeds local plumbing code requirements, adjust the Thermostatic Cooling Valve (TCV) out for a lower drain temperature and in for a higher drain temperature. A TCV setting of approximately 2.75 yields a drain temperature of 140°F. A setting of approximately 2.5 or 3 yields temperatures of 125°F and 155°F, respectively.

OPERATION

CAUTION

If you smell gas during the lighting procedure, immediately shut off the gas supply until the leak has been corrected.

LIGHTING

NOTICE

Do not attempt to operate this unit in the event of a power failure.

1. Ensure power, gas and water supply is on.
2. Turn power switch "ON".
3. Steam generator tanks will begin filling with water.
4. Once proper water level has been reached, the ignition light will come on and should remain on.
5. Cooker is now ready for use.

Your steamer has been factory set, when "ON" to maintain water temperature during the READY phase at approximately 205° Fahrenheit (97° Celsius) just below water boiling point.

CAUTION

The appliance and its parts are hot. Use care when operating, cleaning and servicing the appliance.

CAUTION

Live steam and accumulated hot water in the compartment may be released when the door is opened.

CAUTION

An obstructed drain can cause personal injury or property damage.

WARNING

In the event of main burner ignition failure, a 5 minute purge period must be observed prior to re-establishing ignition source.

WARNING

In the event you smell gas, shut down equipment at the main shut off valve and contact the local gas company or gas supplier for service.

 **WARNING**

When this appliance is installed with casters and is connected to the supply piping by means of a connector for moveable appliances, a restraint to prevent damage to the connector or quick disconnect device should have been installed. If disconnection of the restraint is necessary, reconnect this restraint after the appliance has been returned to its originally installed position.

Frequently check that the compartment drain and plumbing is free of all obstructions. Never place food containers, food or food portion bags in the cooking compartment in such a way that the compartment drain becomes obstructed.

 **IMPORTANT**

Each compartment is equipped with a removable drain screen. Frequently check the drain screen for accumulation of food particles. Should food particles accumulate against, or clog the drain screen, remove it, clean it thoroughly and then replace it in its original position.

CONTROLS

- Ready Pilot Light** When lit, indicates steam generator has reached 205° Fahrenheit (97° Celsius) and is ready for the cooking cycle.
- Cooking Pilot Light**..... When lit, indicates that a cooking cycle is in progress.
- Timer** Set the cooking time (0 to 60 minutes) - steam cooking will begin when the door is closed. The cooking cycle will be interrupted if the door is opened during the cooking cycle; resume cooking by closing the door.
- ON** The steam generator will automatically fill and begin heating to the preset temperature Red Pilot will light on the main power switch.
- DELIME** Closes the drain valve while CLR liquid is being poured into the steam generator during the Delime procedure. Amber Pilot will light on the main power switch.
- OFF** The steam generator will drain. No lights.
- Ignition Light**..... When lit, indicates ignition at the pilot.

NOTE: Each cooking compartment has its own steam generator and controls and can be operated independently.

SHUTDOWN

STAND BY

- a. Set timer to "OFF" position and leave door slightly open.

COMPLETE SHUTDOWN

- a. Set timer to "OFF" and turn power switch "OFF". Steam generator will drain automatically.
- b. Turn water supply "OFF".
- c. Close manual gas shut off valve.
- d. Disconnect power supply.

STEAM COOKING

Your steamer efficiently cooks vegetables or other foods for immediate serving. Steam cooking should be carefully time controlled. Keep holding time of hot food to a minimum to produce the most appetizing results. Prepare small batches, cook only enough to start serving, then cook additional amounts to meet demand. Separate frozen foods into smaller pieces to allow more efficient cooking.

Use a pan cover for pre-cooked frozen dishes that cannot be cooked in the covered containers in which they are packed if they require more than 15 minutes of cooking time. When cover is used, approximately one-third additional cooking time is necessary.

Cooking time for frozen foods depends on amount of defrosting required. If time permits, allow frozen foods to partially thaw overnight in a refrigerator. This will reduce their cooking time.

PREPARATION

Prepare vegetables, fruits, meats, seafood and poultry normally by cleaning, separating, cutting, removing stems, etc. Cook root vegetables in a perforated pan unless juices are being saved. Liquids can be collected in a solid 12" x 20" pan placed under a perforated pan. Perforated pans are used for frankfurters, wieners and similar items when juices do not need to be preserved. Solid pans are good for cooking puddings, rice and hot breakfast cereals. Vegetables and fruits are cooked in solid pans in their own juices. Meats and poultry are cooked in solid pans to preserve their own juices or to retain broth. Canned foods can be heated in their opened cans (cans placed in 12" x 20" solid pans) or the contents may be poured into solid pans.

PANS

The steamer compartment is designed to accept combinations of 12 inches x 20 inches pans (either solid or perforated). Each compartment will accommodate ten 1", five 2-1/2", three 4" or two 6" pans.

MAINTENANCE

NOTICE

Contact the factory, the factory representative or local service company to perform maintenance and repairs.

WARNING

Disconnect the power supply to the appliance before cleaning or servicing.

CAUTION

The appliance and its parts are hot. Use care when operating, cleaning and servicing the appliance.

CAUTION

Live steam and accumulated hot water in the compartment may be released when the door is opened.

DAILY:

CLEANING

At the end of each day, or between cooking cycles if necessary:

1. Turn main power switch OFF.
2. Remove pans and racks from compartment and wash in sink.
3. Wash compartment interior with clean water.
4. Use warm soapy water with a cloth or sponge to clean exposed bead of door gasket, rinse with warm clear water and wipe with a dry cloth.

Wipe surfaces which touch door gasket with a cloth or sponge and warm soapy water, rinse with warm clear water and wipe with a dry cloth. Do not apply food oils or petroleum solvents or lubricants directly to door gasket or surfaces which touch door gasket.

5. Wipe all solids away from drain opening in compartments to prevent clogging.

Keep cooking compartment drain working freely. After cooking grease producing foods, operate steam with compartment empty for 30 minutes at end of the day, or pour ½ gallon of warm soapy water down the drain, followed by 1/2 gallon of warm clear water.

6. Leave door slightly open when steamer is not in use.

WEEKLY (OR MORE OFTEN IF NECESSARY):

1. Clean exterior with a damp cloth and polish with a soft dry cloth.
2. Use a non-abrasive cleaner to remove discolorations.
3. Clean around burner air mixer and orifice if lint has accumulated.

It is **NOT RECOMMENDED** to use cleaning agents that are corrosive.

Use of cleaning agents that contain chloride, acids or salts which are corrosive may cause pitting and corrosion when used over a period of time; this will reduce the life of the appliance.

Should pitting or corrosion occur, this is not covered by the warranty.

Follow the recommended cleaning instructions. Use a mild detergent, warm water and rinse thoroughly.

Never spray water into electric controls.

Following daily and period maintenance procedures will enhance the long-life for your equipment. Climactic conditions - salt air - may require more thorough and frequent cleaning otherwise the life of the equipment could be adversely affected.

STAINLESS STEEL

To remove normal dirt, grease or product residue from stainless steel, use ordinary soap and water (with or without detergent) applied with a sponge or cloth. Dry thoroughly with a clean cloth. Never use vinegar or any corrosive cleaner.

To remove grease and food splatter or condensed vapours that have baked on the equipment, apply cleanser to a damp cloth or sponge and rub cleanser on the metal in the direction of the polishing lines on the metal. Rubbing cleanser as gently as possible in the direction of the polished lines will not mar the finish of the stainless steel. **NEVER RUB WITH A CIRCULAR MOTION.**

Soil and burnt deposits which do not respond to the above procedure can usually be removed by rubbing the surface with SCOTCH-BRITE scouring pads or STAINLESS scouring pads. DO NOT USE ORDINARY STEEL WOOL as any particles left on the surface will rust and further spoil the appearance of the finish. NEVER USE A WIRE BRUSH, STEEL SCOURING PADS (EXCEPT STAINLESS), SCRAPER, FILE OR OTHER STEEL TOOLS. Surfaces which are marred collect dirt more rapidly and become more difficult to clean. Marring also increases the possibility of corrosive attack. Refinishing may then be required.

TO REMOVE HEAT TINT

Darkened areas sometimes appear on the stainless steel surface where the area has been subjected to excessive heat. These darkened areas are caused by thickening of the protective surface of the stainless steel and are not harmful. Heat tint can normally be removed by the foregoing, but tint which does not respond to this procedure calls for a vigorous scouring in the direction of the polish lines using SCOTCH-BRITE scouring pads or a STAINLESS scouring pad in combination with a powdered cleanser. Heat tint action may be lessened by not applying or by reducing heat to equipment during slack periods.

MONTHLY

REMOVAL OF SCALE DEPOSITS

It is recommended that your steamer be delimed once a month, or more often if necessary.

Should your steamer develop a heavy build-up of lime scale deposits, use the CLR TREATMENT KIT available from your authorized servicer.

Before beginning deliming procedures, ensure that water is not overflowing into the cooking compartment.

DELIMING PROCEDURE

CAUTION

Read and follow instructions on the CLR bottle. Use plastic or rubber gloves to avoid skin contact. If CLR comes in contact with skin, rinse with clean water.

1. Completely drain steam generator by setting on/off switch to "OFF". Set cooking timer to 0.
2. Set on/off switch to DELIME.
3. Unscrew delimiting port located in front of generator. Screw in the supplied delimiting funnel. Make sure funnel is in upright position. Pour 20 ounces of solution into generator slowly to avoid spillage. Use a towel to protect the burners below from any spillage that may occur. Remove funnel and screw in delime port cap securely. Turn on/off switch to "ON".
4. Operate steamer in READY cycle for ½ hour, then turn on/off switch "OFF" and allow generator to drain.
5. Flush cycle. Turn on/off switch to "ON". When ready light comes on, switch to "OFF" to flush generator. Repeat this step three times to completely flush generator.
6. Clean exterior and interior. Use a mild solution of soap and water. Rinse with clean water. Dry with a soft cloth. LEAVE COMPARTMENT DOOR OPEN WHEN NOT IN USE.

The steamer is now ready for use. Turn off for overnight shutdown.

TWICE A YEAR

At least twice a year, have an authorized service person clean and adjust the unit for maximum performance.

All units are adjusted at the factory. In case of operation problems at initial installation, check type of gas supply and manifold pressure and compare it with information on the rating plate.

WARNING

Adjustments and service work may be performed only by a qualified technician who is experienced in, and knowledgeable with the operation of commercial gas cooking equipment. However, to assure your confidence, contact your authorized service agency for reliable service, dependable advice or other assistance and for genuine factory parts.

TROUBLESHOOTING

BURNERS NO NOT COME ON

1. Gas supply to unit is “OFF”.
2. Power Switch is not turned “ON”.
3. Steam generator probe not sensing the water level, will not call for ignition.
4. Ignitor not functioning.
5. Gas combination supply valve not opening.

BURNERS PRODUCE CARBON DEPOSITS

1. Wrong orifice size.
2. Wrong gas supply.
3. Incorrect pressure at supply.
4. Not enough primary air.

WATER FLOWS INTO COOKING COMPARTMENT

Probes not sensing water, thereby not operating fill solenoid.

1. Scale build-up on operating probe inside the generator.
2. Water fill solenoid valve is not closed. Check for scale or foreign particles lodged in diaphragm or core tube of valve.

These problems are an indication of severe harmful water conditions which should be corrected immediately to avoid damage to the components and performance of the steamer.

DOOR LEAKS

1. Check for damage to door gasket.
2. Clogged compartment drain or plumbing.

WATER ACCUMULATES IN THE COMPARTMENT

1. Compartment drain clogged.

WATER FLOWS INTO DRAIN DURING SHUT DOWN

1. Condensate valve does not close. Check thermostatic cooling valve body for foreign particles or damage.
2. Water fill solenoid valve is not closed. Check for scale or foreign particles lodged in diaphragm or core tube of valve.

WATER NOT BEING SUPPLIED TO STEAM GENERATOR

1. Water supply is “OFF”.
2. Supply water pressure too low.
3. Defective water fill solenoid valve.
4. Shortage of circuit between probes and body.
5. Check that drain solenoid is closed.

NOTES

NOTES

NOTES

GSX-10HE & GSX-16HE Gas Skillets



A product with the Crown name incorporates the best in durability and low maintenance. We all recognize, however, that replacement parts and occasional professional service may be necessary to extend the useful life of this appliance. When service is needed, contact a Crown Authorized Service Agency, or your dealer. To avoid confusion, always refer to the model number, serial number, and type of your appliance.



CROWN FOOD SERVICE EQUIPMENT

 A Middleby Company

70 Oakdale Road, Downsview (Toronto) Ontario, Canada, M3N 1V9
Telephone: 919-762-1000 www.crownsteamgroup.com