



Item # 211-4758 Model # M27BC

Item # 211-4759 Model # M27BCTB

Item # 211-4760 Model # M27BCTR

Item # 211-4761 Model # M27BCW

USE AND CARE GUIDE

27 IN 2-Door Base Cabinet

Questions, problems, missing parts?

Before returning to the store, call

1-866-441-5080

9 a.m – 5 p.m., CST, Monday-Friday



Table of Contents

Table of Contents.....	2	Assembly	5
Safety Information	2	Operation	6
Warranty	3	Maintenance.....	7
Specifications	3	Replacement Parts	7
Package Contents.....	3-4		

Safety Information

1. Do not pull this unit, push it when moving.
2. Use the brakes when this product is not being moved. This prevents the product from rolling.
3. Secure this product properly before moving it with a forklift.
4. Do not tow the product with power equipment.
5. Do not alter this product in any manner. For example, do not weld external lock bars or attach electrical equipment.



CAUTION: Lock the door before moving this product. The doors could come open and make the product unstable and tip, which may cause personal or product damage.



CAUTION: Do not attach or mount this product to a vehicle or mobile trailers. This may cause personal injury or product damage. Mounting this product to any vehicle or mobile trailers in any manner will void warranty.



CAUTION: Do not stand on this product. You may fall which may cause personal injury or product damage.



CAUTION: Keep the product on level surfaces. The product may become unstable and tip if stored or moved on an unlevel surface, which may cause personal injury or product damage.

Limited Lifetime Warranty

PERFORMAX® Tool Cabinets and Chests are warranted to be free from defects in materials and workmanship under normal use for the lifetime that you own the product. If any part of the product is found to be defective during normal use, the defective product or part will be replaced at our discretion. This warranty does not cover products that are damaged through accident, abuse, misuse, commercial/industrial applications or neglect. This warranty also does not cover any losses, injuries or costs including indirect, incidental or consequential damages. This warranty may not be transferred or sold. When requesting warranty service please call 1-866-441-5080 and have the model number, cash register receipt and the date of purchase available when you call. If the product is defective, we will replace the defective part at no cost to you. Some states do not allow the exclusion or limitation of incidental damages, so the above limitations or exclusions may not apply to you. This warranty gives you specific legal rights and you may have other rights, which vary from state to state.

Specifications

Maximum weight per (shelf)	100 lbs.
Casters support up to	600 lbs.



NOTE: Begin product assembly close to the final intended location of your cabinet. This product is heavy and may be difficult to move after assembly.

Package Contents

HARDWARE INCLUDED



NOTE: Hardware not shown to actual size.



AA



BB



CC

Part	Description	Quantity
AA	M8 x 20 bolt	16
BB	M6 x 16 bolt	8
CC	Hex key	1

Package Contents (continued)



NOTE: Cabinet Keys are inside shelf.

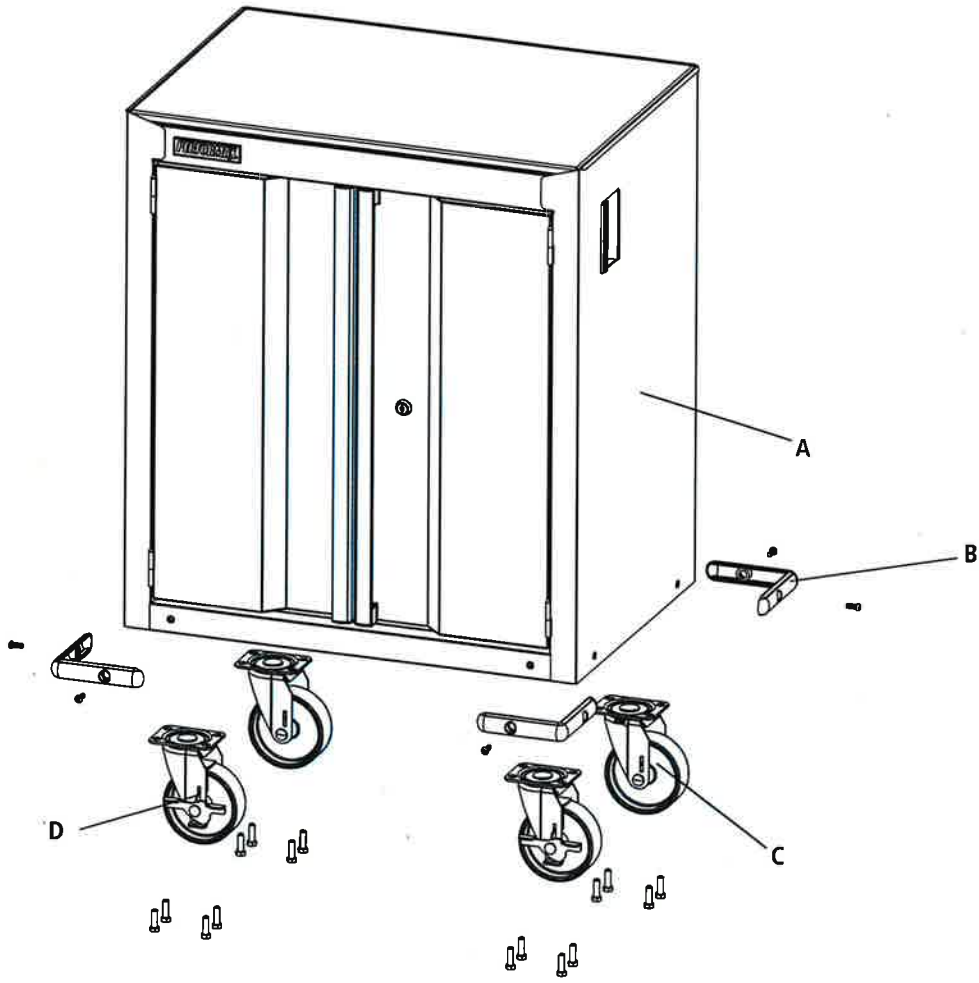

Part	Description	Quantity
A	Cabinet	1
B	Bumper	4
C	Swivel caster without brake	2
D	Swivel caster with brake	2

Assembly



CAUTION: Two people are recommended for assembly.

1 Attaching the casters

- Be sure the doors are locked and lay the cabinet (A) on its back. Use packaging material to protect the finish.
- Attach the swivel casters with brake (D) on the front of the unit inserting four bolts (AA) per caster into the cabinet (A).
- Tighten with supplied hex key (CC).
- Attach the swivel casters without brake (C) on the back of the unit inserting four bolts (AA) per caster into the cabinet (A).
- Return the cabinet (A) to its upright position.



CAUTION: Do not over tighten the bolts.

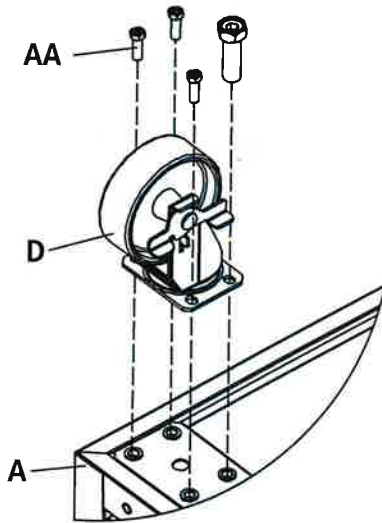

2 Attaching the bumpers

- Position the bumpers (B) over the corner holes. Insert 2 bolts (BB) into bumper holes and tighten with supplied Hex key (CC). Do not over tighten.

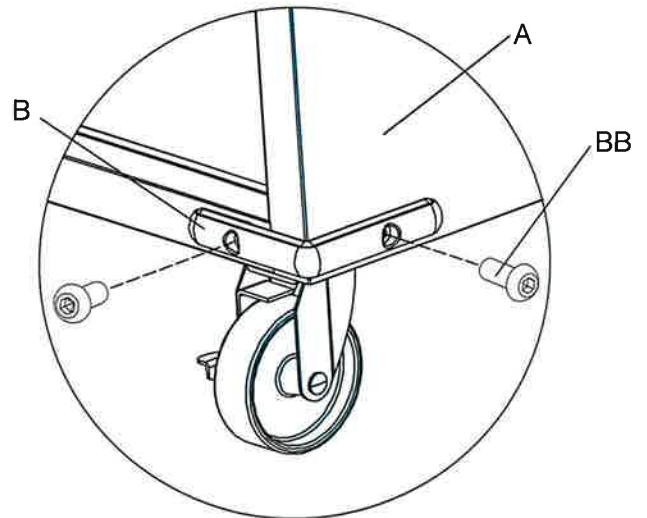

Operation

1 Removing the sliding tray

- Fully extend the empty sliding tray.
- Push up the one release lever while pulling down on the other release lever.
- Pull the tray outward until it is released from the tray slide.

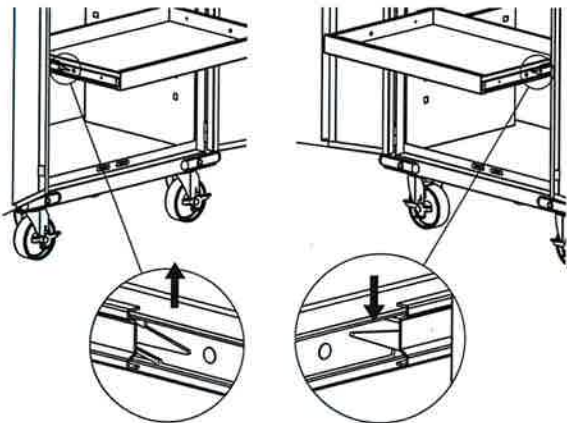

2 Sliding tray height adjustment

- With the sliding tray removed, push up at the front of the outer slide to release the clip from the side panel groove and then pull outward to remove.
- Determine the desired height of your shelf.
- Insert the back clip of the outer slide, and then push down to lock the front clip into the groove of the side panel.

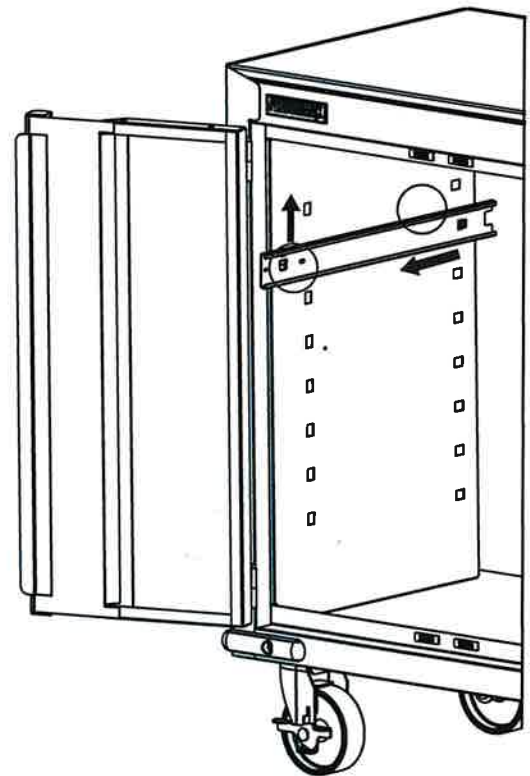

3 Re-inserting the sliding tray

- Extend the tray slides.
- Insert the brackets on each side of the tray into the slots in the slides, being careful that they are properly positioned.
- Once properly inserted, completely close the tray to set the slides in their proper positions.

Maintenance

1 Caster maintenance

- Grease the casters annually using high-quality bearing grease.



2 Drawer maintenance

- Lubricate the slides semi-annually with high-quality bearing grease.

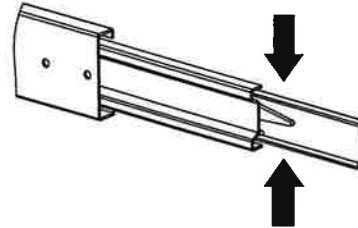

- Periodically clean the drawer fronts, drawer trim, and other surfaces with a mild detergent and water.
- Remove grease and oil with a standard nonflammable cleaning fluid.

Replacement Parts

For assistance with replacement parts please call 1-866-441-5080.

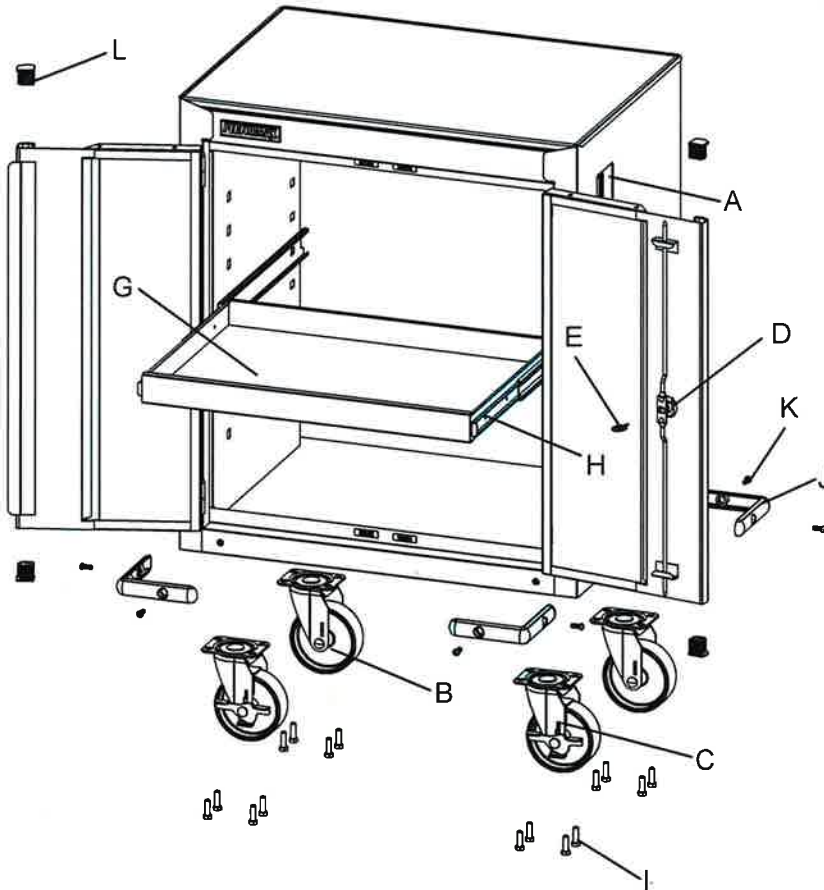

Part	Description	Quantity
A	Cabinet Handle	2
B	Swivel Caster without brake	2
C	Swivel Caster with brake	2
D	Lock	1
E	Key	2
F	Badge	1
G	Drawer Liner	1
H	Drawer Slide	2
I	Caster Bolt	16
J	Bumper	4
K	Bumper Bolt	8
L	Plastic Cap	4



Item # 211-4766 Model # M27BC5

Item # 211-4767 Model # M27BC5TB

Item # 211-4768 Model # M27BC5TR

Item # 211-4769 Model # M27BC5W

USE AND CARE GUIDE

27 IN 5-Drawer Base Cabinet

Questions, problems, missing parts?

Before returning to the store, call

1-866-441-5080

9 a.m – 5 p.m., CST, Monday-Friday

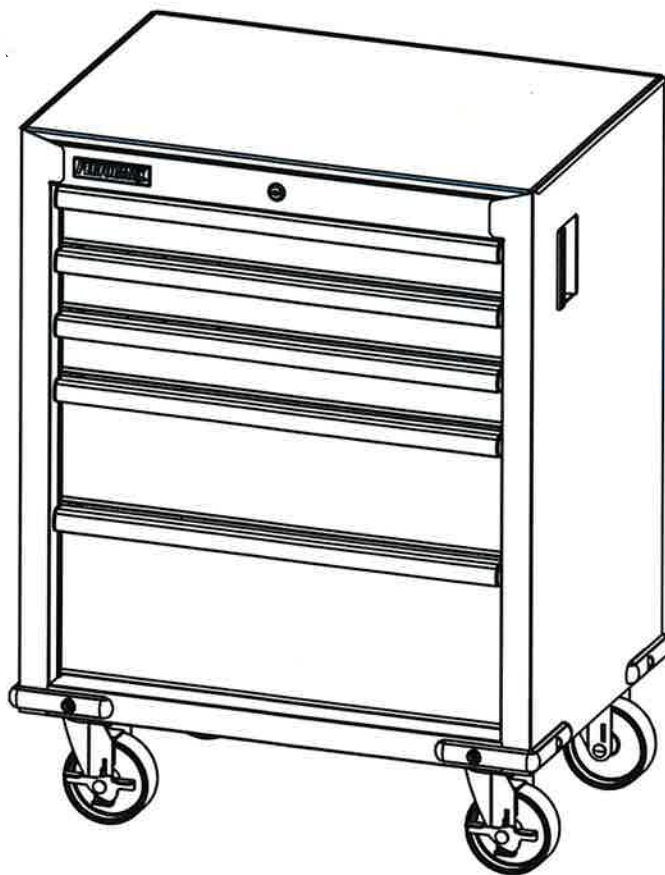

Table of Contents

Table of Contents.....	2	Assembly	5
Safety Information	2	Operation	6
Warranty	3	Maintenance.....	6
Specifications	3	Replacement Parts	7
Package Contents.....	3-4		

Safety Information

1. Do not pull this unit, push it when moving.
2. Use the brakes when this product is not being moved. This prevents the product from rolling.
3. Secure this product properly before moving it with a forklift.
4. Do not tow the product with power equipment.
5. Do not alter this product in any manner. For example, do not weld external lock bars or attach electrical equipment.
6. Before locking the cabinet, ensure the drawers are completely closed in order for the lock bars to work properly.



CAUTION: Keep the product on level surfaces. The product may become unstable and tip if stored or moved on an unlevel surface, which may cause personal injury or product damage.



CAUTION: Lock the drawers before moving this product. The drawers could come open and make the product unstable and tip, which may cause personal or product damage.



CAUTION: Load unit starting with bottom drawers. Overloading the top of the unit may result in the product becoming unstable and creating a tipping hazard, which may cause personal injury or product damage.



CAUTION: Do not attach or mount this product to a vehicle or mobile trailers. This may cause personal injury or product damage. Mounting this product to any vehicle or mobile trailers in any manner will void warranty.



CAUTION: Do not stand on this product. You may fall which may cause personal injury or product damage.



CAUTION: Be careful when opening more than one drawer. The product may become unstable and tip, which may cause personal injury or product damage.

Limited Lifetime Warranty

PERFORMAX® Tool Cabinets and Chests are warranted to be free from defects in materials and workmanship under normal use for the lifetime that you own the product. If any part of the product is found to be defective during normal use, the defective product or part will be replaced at our discretion. This warranty does not cover products that are damaged through accident, abuse, misuse, commercial/industrial applications or neglect. This warranty also does not cover any losses, injuries or costs including indirect, incidental or consequential damages. This warranty may not be transferred or sold. When requesting warranty service please call 1-866-441-5080 and have the model number, cash register receipt and the date of purchase available when you call. If the product is defective, we will replace the defective part at no cost to you. Some states do not allow the exclusion or limitation of incidental damages, so the above limitations or exclusions may not apply to you. This warranty gives you specific legal rights and you may have other rights, which vary from state to state.

Specifications

Maximum weight per (cabinet drawer)	100 lbs.
Casters support up to	600 lbs.



NOTE: Begin product assembly close to the final intended location of your cabinet. This product is heavy and may be difficult to move after assembly.

Package Contents

HARDWARE INCLUDED



NOTE: Hardware not shown to actual size.



AA



BB



CC

Part	Description	Quantity
AA	M8 x 20 bolt	16
BB	M6 x 16 bolt	8
CC	Hex key	1

Package Contents (continued)



NOTE: Cabinet Keys are inside top drawer.

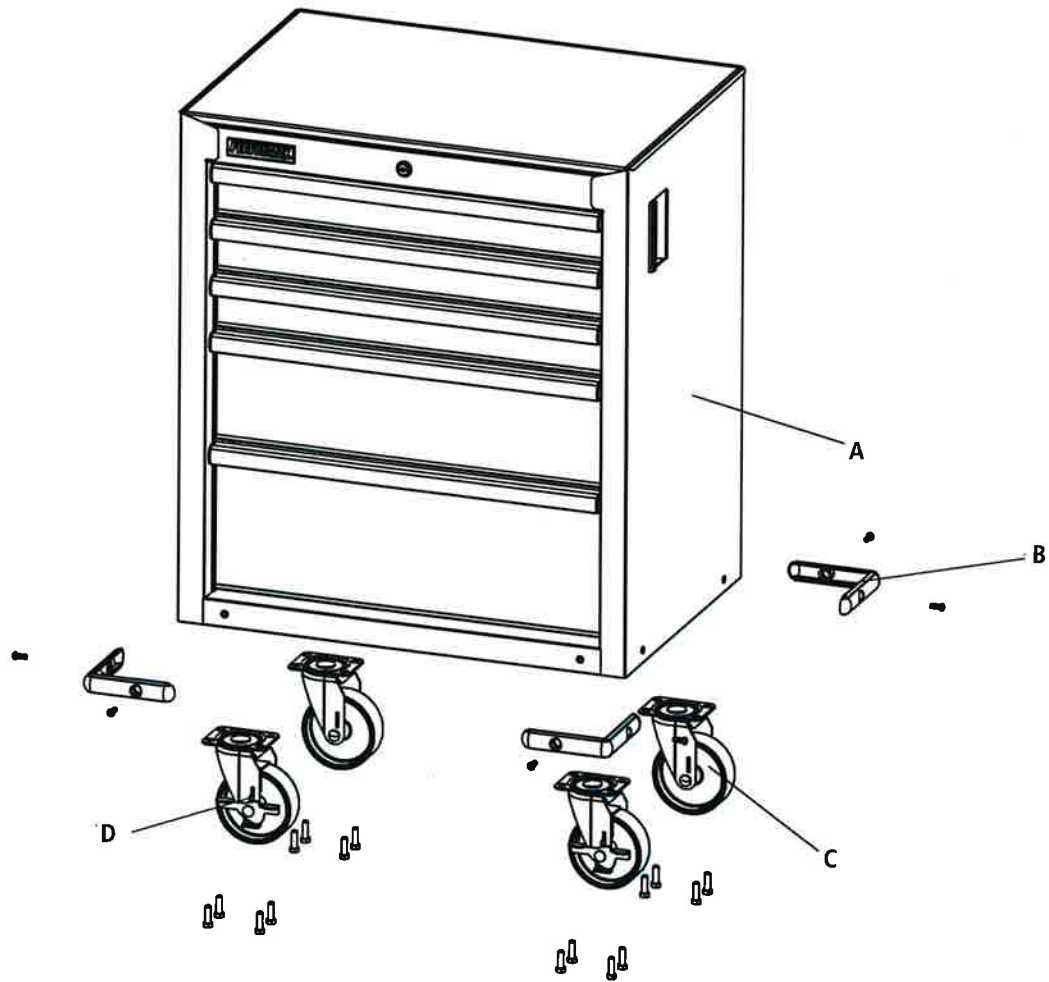

Part	Description	Quantity
A	Cabinet	1
B	Bumper	4
C	Swivel caster without brake	2
D	Swivel caster with brake	2

Assembly



CAUTION: Two people are recommended for assembly.

1 Attaching the casters

- Be sure the drawers are locked and lay the cabinet (A) on its back. Use packaging material to protect the finish.
- Attach the swivel casters with brake (D) on the front of the unit inserting four bolts (AA) per caster into the cabinet (A).
- Tighten with supplied hex key (CC).
- Attach the swivel casters without brake (C) on the back of the unit inserting four bolts (AA) per caster into the cabinet (A).
- Return the cabinet (A) to its upright position.



CAUTION: Do not over tighten the bolts.

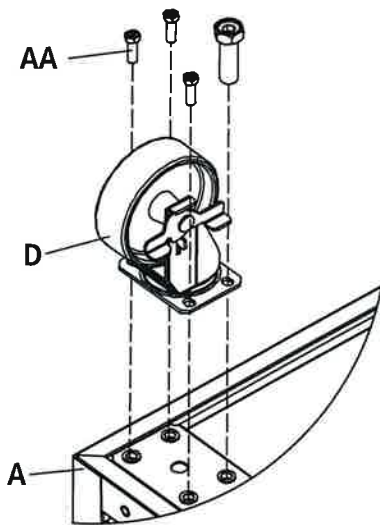

2 Attaching the bumpers

- Position the bumpers (B) over the corner holes. Insert 2 bolts (BB) into bumper holes and tighten with supplied Hex key (CC). Do not over tighten.

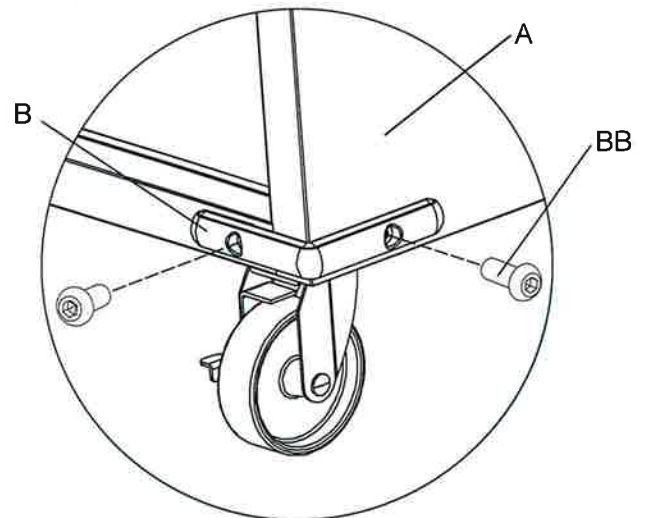

Operation

1 Removing the drawers

- Fully extend the empty drawer.
- Push up the one release lever while pulling down on the other release lever.
- Pull the drawer outward until it is released from the drawer slide.

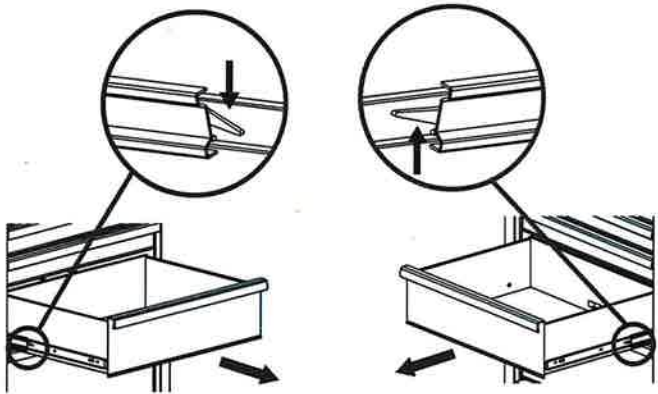

2 Re-inserting the drawers

- Extend the drawer slides.
- Insert the brackets on each side of the drawer into the slots in the slides, being careful that they are properly positioned.
- Once properly inserted, completely close the drawer to set the slides in their proper positions.

Maintenance

1 Caster maintenance

- Grease the casters annually using high-quality bearing grease.

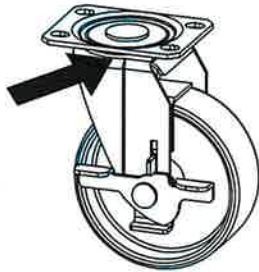

2 Drawer maintenance

- Lubricate the slides semi-annually with high-quality bearing grease.

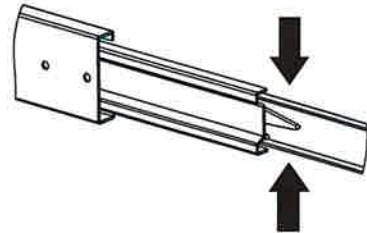

- Periodically clean the drawer fronts, drawer trim, and other surfaces with a mild detergent and water.
- Remove grease and oil with a standard nonflammable cleaning fluid.

Replacement Parts

For assistance with replacement parts please call 1-866-441-5080.

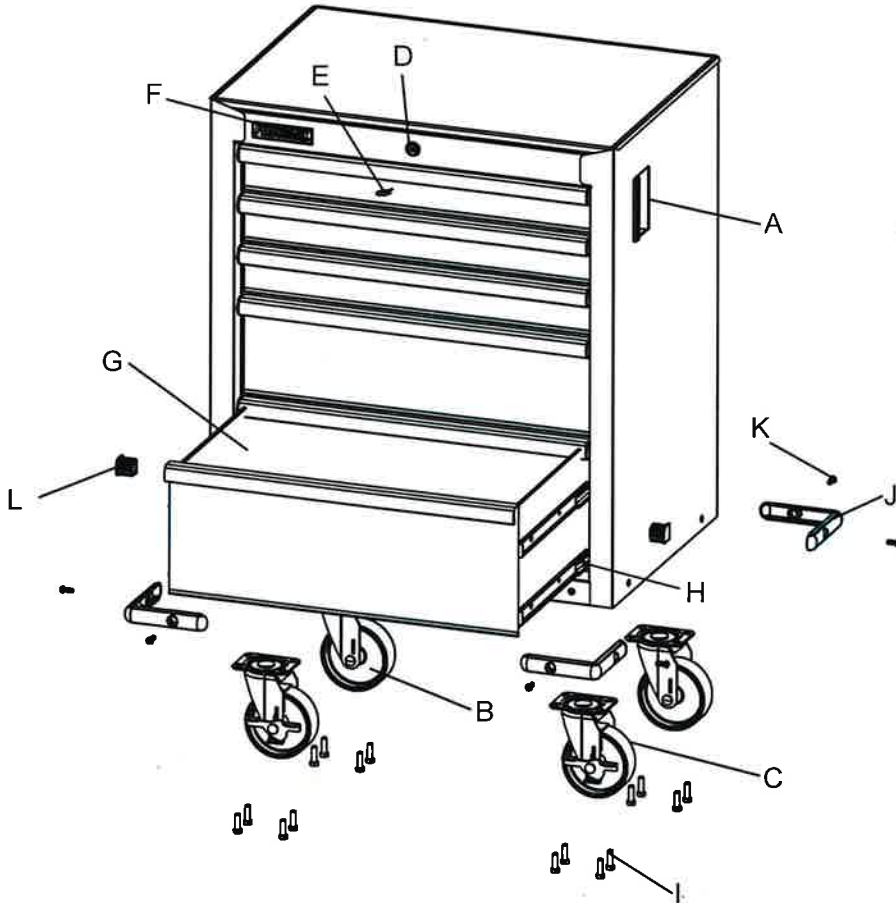

Part	Description	Quantity
A	Cabinet Handle	2
B	Swivel Caster without brake	2
C	Swivel Caster with brake	2
D	Lock	1
E	Key	2
F	Badge	1
G	Drawer Liner	5
H	Drawer Slide	12
I	Caster Bolt	16
J	Bumper	4
K	Bumper Bolt	8
L	Plastic Cap	10

Assembly Instructions



Item #211-4794 Model # M72WB
Item #211-4795 Model # M72WBTB
Item #211-4796 Model # M72WBTR
Item #211-4797 Model # M72WBW

USE AND CARE GUIDE

72 IN Adjustable Height Workbench With Pegboard

Questions, problems, missing parts?
Before returning to the store, call
1-866-441-5080
9 a.m – 5 p.m., CST, Monday-Friday

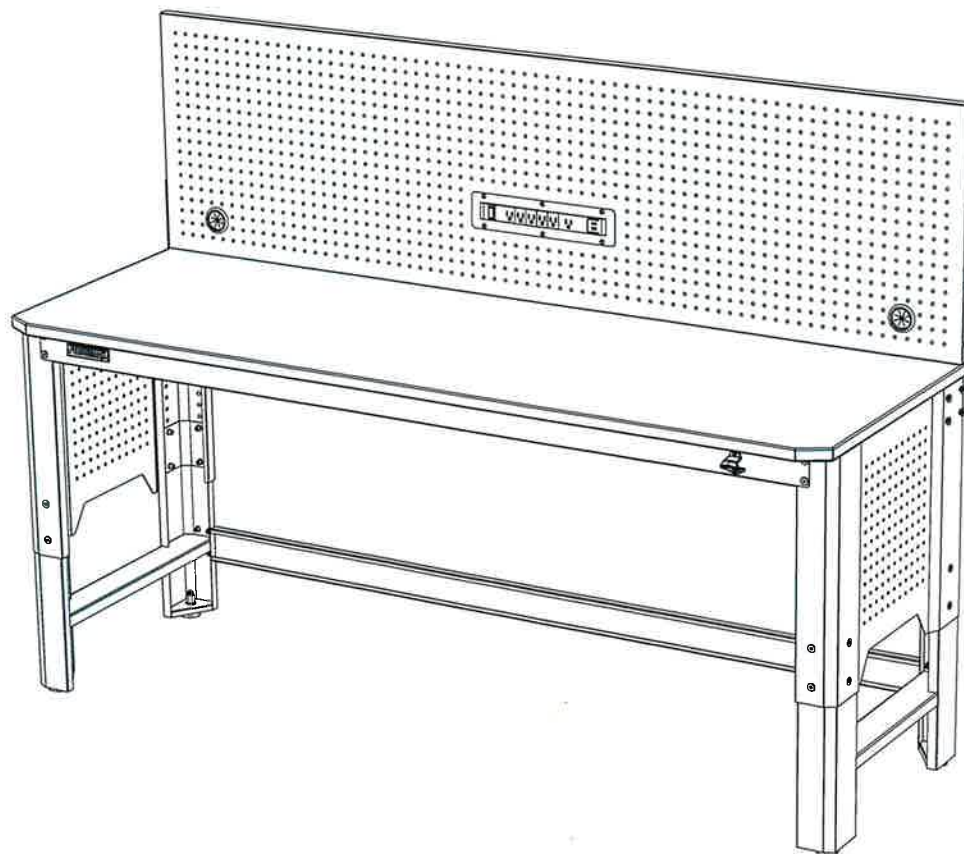

Table of Contents

Table of Contents.....	2	Assembly	6-8
Safety Information	2-3	Operation	9
Warranty	4	Cordless Power Tool Battery Chargers	9
Specifications	4	Maintenance.....	10
Package Contents.....	4-5	Replacement Parts	10

Safety Information

1. Use appropriate safety equipment when using power and hand tools. Failure to do so may cause personal injury or product damage.
2. Obtain the aid of an assistant to assemble and move this unit. Failure to do so may cause personal injury or product damage.
3. This product is intended for indoor use only.
4. Do not alter this product in any manner. This product is not designed for commercial or industrial use.
5. Check all bolts periodically and tighten if needed.



CAUTION: indicates a hazardous situation which, if not avoided, could result in product damage or personal injury.



CAUTION: Read and follow all Safety Rules and Operating Instructions before first use of this product.



CAUTION: Do not attach or mount this product to a vehicle or mobile trailers. This may cause personal injury or product damage. Mounting this product to any vehicle or mobile trailers in any manner will void warranty.



CAUTION: Do not stand on this product. You may fall which may cause personal injury or product damage.



CAUTION: Keep the product on level surfaces. The product may become unstable and tip if stored or moved on an unlevel surface, which may cause personal injury or product damage.

7. Extension cord

- Follow all manufacturers' Warnings and Operating Instructions for your extension cord.
- Do not insert extension cord through hole without grommet in place.
- Only use a three-wire extension cord with all three prongs intact. Never remove the round grounding prong.
- Extension cord must be connected to a 125 Volt GFCI protected outlet with proper ground. If GFCI outlet is not available, use an extension cord with GFCI protection built in.
- Check the insulation and plugs of extension cord before using. Do NOT use cord if it is worn or damaged.
- Do NOT overload extension cord.
- Remove extension cord from the hole before moving or transporting storage cabinet.
- Only use an extension cord that is rated for outdoor use.
- Do NOT connect extension cord to outlet that also supplies critical safety equipment with power.

8. Electrical Shock Hazard

- Do not plug cord into outlet with wet hands.
- Do not use this product near a bathtub, a shower, or a swimming pool.
- Product plugs must match the outlet.
- Never modify the plug in any way.
- Do not use any adapter plugs with earth (grounded) cabinet power strips.
- Unmodified plugs and matching outlets will reduce the risk of electric shock.
- Avoid body contact with earthed or grounded surfaces. There is an increased risk of electric shock if your body is earthed or grounded.



WARNING: Changes or modifications to this unit not expressly approved by the party responsible for compliance could void the user's authority to operate the equipment.



NOTE: This device complies with Part 15 of the FCC Rules. Operation is subject to the following two conditions: (1) this device may not cause harmful interference, and (2) this device must accept any interference received, including interference that may cause undesired operation.



NOTE: This equipment has been tested and found to comply with the limits for a Class B digital device, pursuant to Part 15 of the FCC Rules. These limits are designed to provide reasonable protection against harmful interference in a residential installation. This equipment generates, uses and can radiate radio frequency energy and, if not installed and used in accordance with the instructions, may cause harmful interference to radio communications. However, there is no guarantee that interference will not occur in a particular installation.

If this equipment does cause harmful interference to radio or television reception, which can be determined by turning the equipment off and on, the user is encouraged to try to correct the interference by one or more of the following measures:

- Reorient or relocate the receiving antenna.
- Increase the separation between the equipment and receiver.
- Connect the equipment into an outlet on a circuit different from that to which the receiver is connected.
- Consult the dealer or an experienced radio/TV technician for help.



CAUTION: RISK OF ELECTRICAL SHOCK: This unit has one power supply cord. Make sure the cord is unplugged before any servicing or cleaning.

Limited Lifetime Warranty

PERFORMAX® Workbenches are warranted to be free from defects in materials and workmanship under normal use for the lifetime that you own the product. If any part of the product is found to be defective during normal use, the defective product or part will be replaced at our discretion. This warranty does not cover products that are damaged through accident, abuse, misuse, commercial/industrial applications or neglect. This warranty also does not cover any losses, injuries or costs including indirect, incidental or consequential damages. This warranty may not be transferred or sold. When requesting warranty service please call 1-866-441-5080 and have the model number, cash register receipt and the date of purchase available when you call. If the product is defective, we will replace the defective part at no cost to you. Some states do not allow the exclusion or limitation of incidental damages, so the above limitations or exclusions may not apply to you. This warranty gives you specific legal rights and you may have other rights, which vary from state to state.

Specifications

Workbench Maximum Load Capacity	2000 lbs.
--	-----------

 **NOTE:** Begin product assembly close to the final intended location of your workbench. This product is heavy and may be difficult to move after assembly.

Package Contents

HARDWARE INCLUDED

 **NOTE:** Hardware not shown to actual size.



ALTERNATIVE TOOLS FOR ASSEMBLY (Not Included)



Part	Description	Quantity
AA	M6x12 Screw	73
BB	M4x12 Screw	2
CC	Leveling Feet	4



Package Contents (continued)

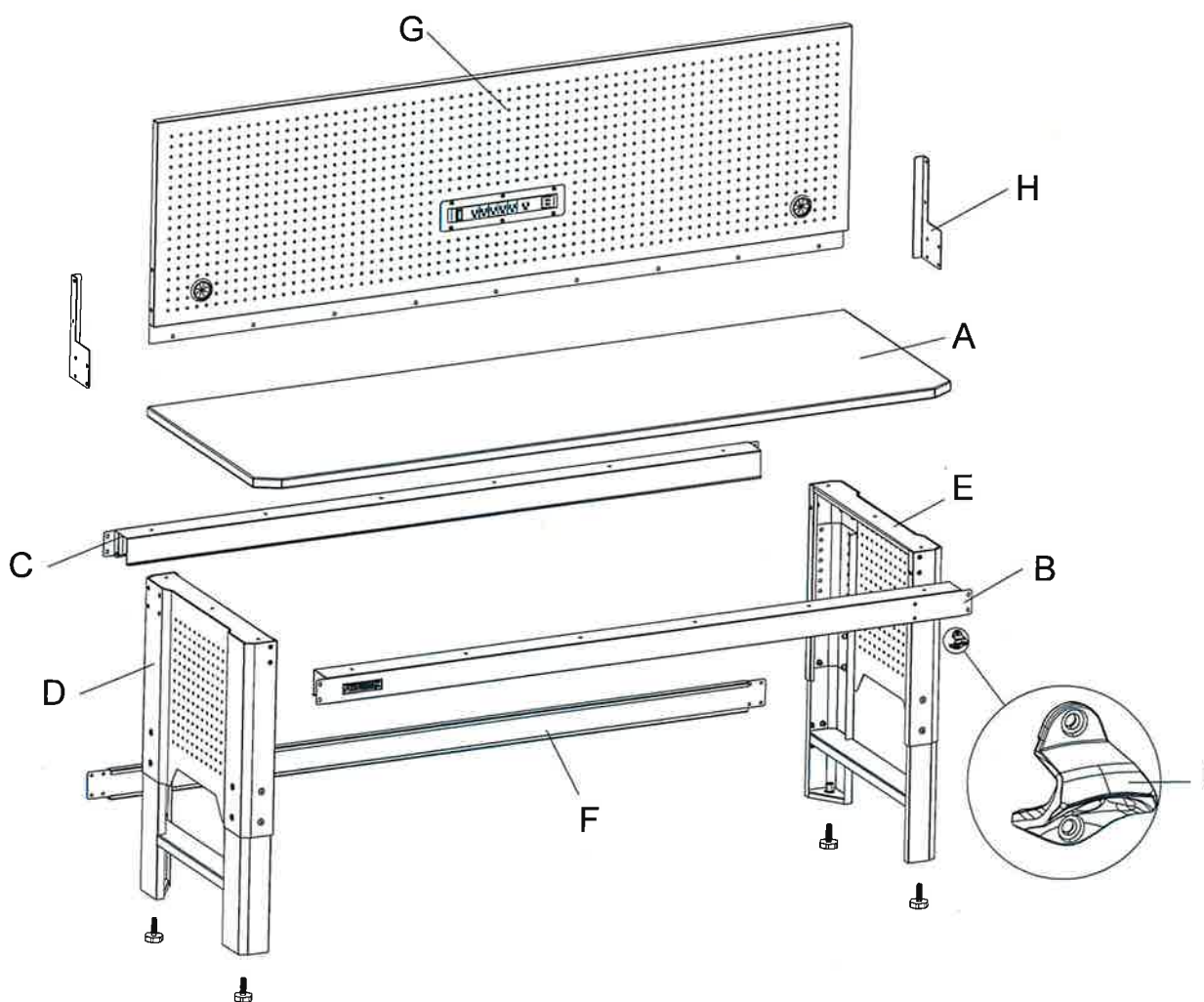

Part	Description	Quantity	Part	Description	Quantity
A	Workbench Wood Table	1	F	Back Rail	1
B	Front Crossbar	1	G	Pegboard	1
C	Rear Crossbar	1	H	L bracket	2
D	Left Leg Panel	1	I	Bottle Opener	1
E	Right Leg Panel	1			

Assembly



CAUTION: Two people are recommended for assembly.

1 Unpacking instructions

- After opening shipping box, remove protective cardboard from the top of the wood table and place cardboard on the floor.
- With the aid of an assistant, remove wood table and lay topside down on cardboard to protect the wood from scratching.
- Remove the remainder of workbench parts from shipping box. Check parts and hardware against the PARTS and HARDWARE lists on the next page. If parts or hardware are missing, please call 1-866-441-5080 for assistance.

2 Attaching the Leveling Feet

- Attach the four Leveling Feet (CC) to the Left (D) and Right Leg Panels (E) and tighten.

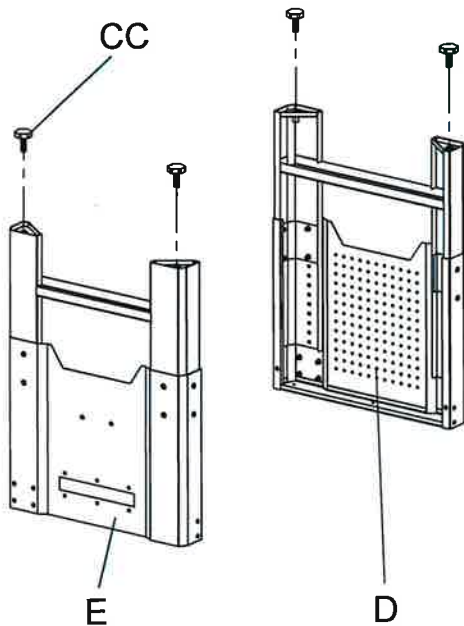

3 Workbench Height Adjustment

The Leg Panels are pre-set for a total workbench height of 36 inches (not including leveling feet). The Leg Panels can be adjusted to alter the workbench height from 32 inches to 42 inches.

- Completely unscrew the Screws (AA) from each Leg Panel as shown in figure below.
- Raise or lower the leg bottoms to the same position in the leg channels on each Leg Panel.
- Insert and securely tighten the previously removed screws.
- Ensure 8 Screws (AA) are used to secure the Leg Panels.

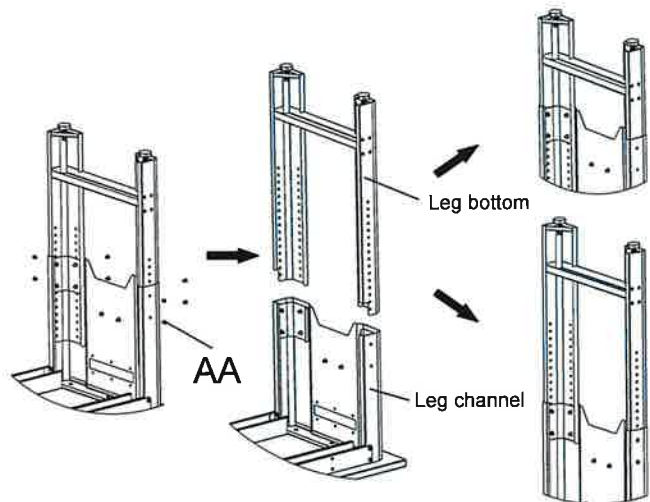

4 Attaching the Wood Table

- Determine the front and back of table. Leg Panels must be attached to the table with Back Rail attachment holes to the back of table.
- Attach the Left (D) and Right Leg Panels (E) to the underside of the Workbench Table (A):
- Align the pre-drilled holes in Table with holes in top of Legs.
- Partially tighten 3 Screws (AA) through each Leg into the Table as shown in the figure below. Do not fully tighten the Screws to allow for proper installation of the Crossbar attachments.

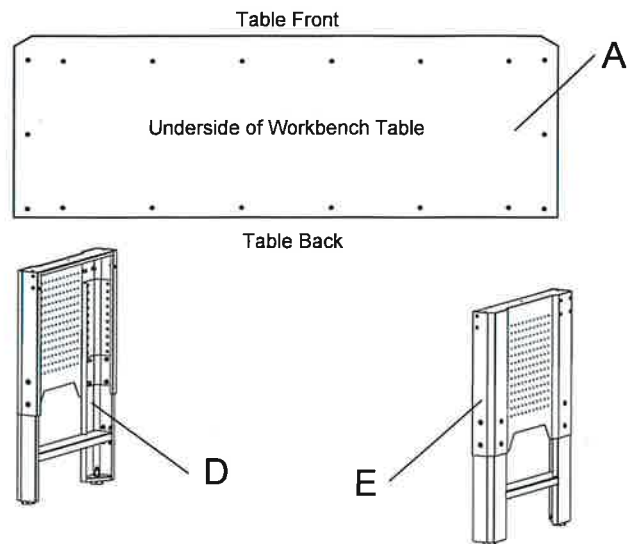

5 Attaching the Crossbars

- The Front Crossbar (B) has PREFORMAX badge.
- Attach Front Crossbar (B) to front of Table and Rear Crossbar (C) to back of Table
- Align the pre-drilled holes in Table with holes in Crossbar length.
- Partially tighten Screws (AA) through each Crossbar (B,C) into Table .
- Align Crossbar (B,C) end holes with holes in Left and Right Legs (D, E).
- On each end of Crossbar, partially tighten screws (AA) through Crossbar holes into Leg holes as shown in figure below. Note: The Crossbar end flanges must be attached so that they are on the outside of the Leg Panels.
- Go back and tighten all Screws (AA)

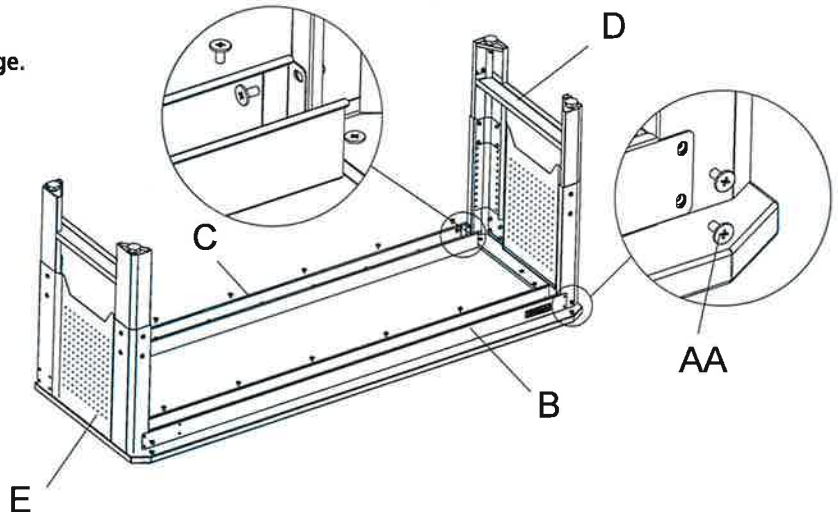

CAUTION: Ensure all Screws are properly tightened before flipping the Workbench over.

6 Attaching the Back Rail

- Attach Back Rail (F) to back of Left and Right Leg Panel (D,E). Align Back Rail end holes with holes in back of Left and Right Legs.
- Install and tighten 4 Screws (AA) through Back Rail end holes into Leg holes as shown in figure below.

Note: The Back Rail end flanges must be attached so that they are on the outside of the Leg Panels.

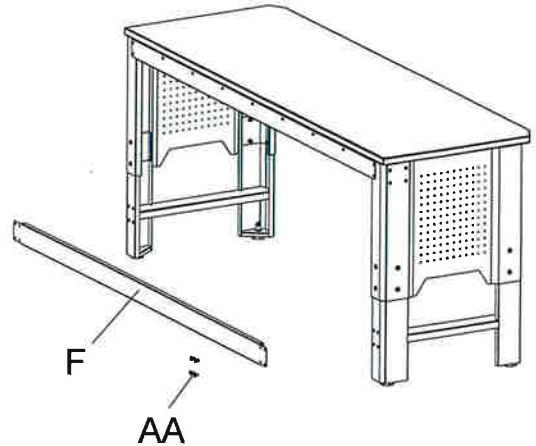

7 Attaching the Pegboard

- With the help of another person, carefully lift the Pegboard (G) into the upright position as shown.
- Align Pegboard (G) end holes with holes in Rear Crossbar (C).
- Install and tighten 11 Screws (AA) through Pegboard (G) holes into Rear Crossbar (C) holes as shown in the figure.

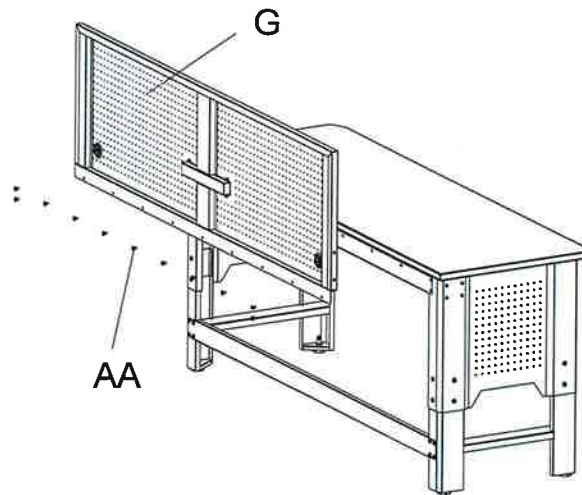

8 Attaching the L bracket

- Position the L-bracket (H) over the holes on the Pegboard (G) and the workbench.
- Tighten 6 Screws (AA) through the L-bracket (H) into Pegboard (G) and the workbench.
- Repeat this process for the other side of the Pegboard (G) to attach it to the workbench.
- Once the L bracket is attached, go back and fully tighten all screws.

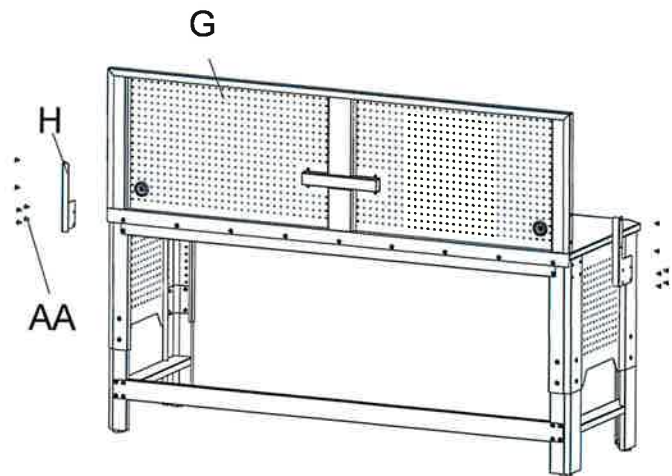

9 Attaching the Bottle Opener

- Tighten 2 Screws (BB) through the Bottle Opener (I) holes into Front Crossbar (B) holes as shown in the figure.

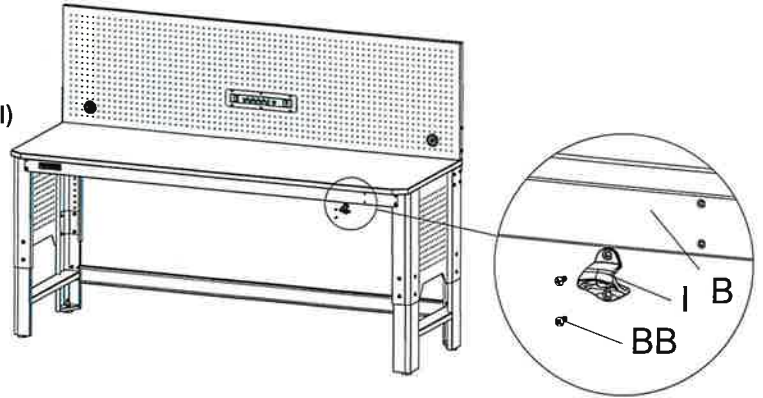

Operation

1 Leveling Foot Adjustment

- Adjust leveling position by turning the foot nut left to raise and right to lower the foot.

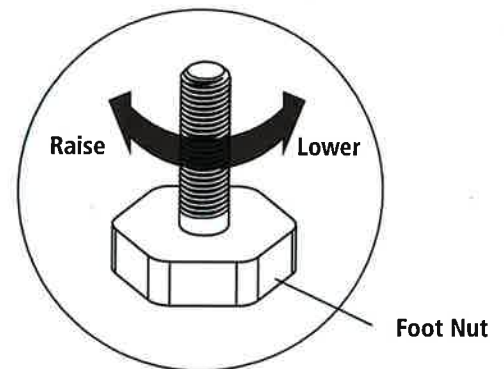

Cordless Power Tool Battery Chargers

- See Charger's Owner's Manual for proper use and care of charger and batteries. Follow all Warnings and Instructions provided with your battery charger.
- Chargers are for use in dry locations only. Do NOT expose to liquid, vapor, or rain. Should your charger become wet, Do NOT attempt to use. Unplug extension cord from supply before handling wet charger or cords.
- Only use chargers and batteries that are intact and operating properly.
- Do NOT touch metal prongs when plugging charger into extension cord.
- Keep flammable materials like paper or rags away from charger, cords or connections.
- Do NOT place or attempt to charge lead acid, car type batteries.

Maintenance

- Periodically the surfaces should be cleaned with a mild detergent and water.

Replacement Parts

For assistance with replacement parts please call 1-866-441-5080.

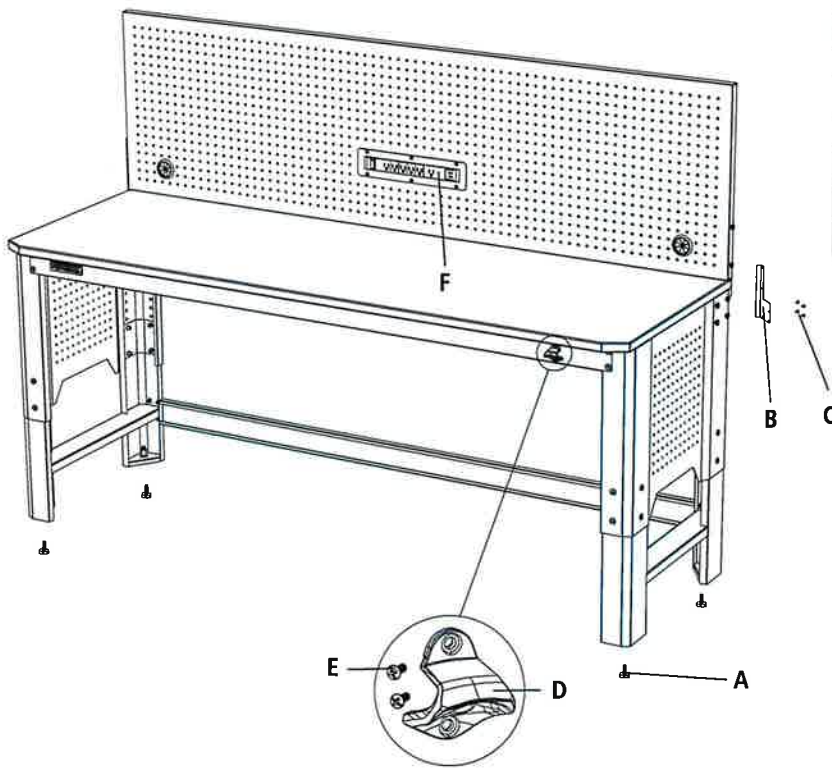

Part	Description	Quantity
A	Leveling Feet	4
B	L bracket	2
C	M6x12 Screw	73
D	Bottle Opener	1
E	M4x12 Screw	2
F	Power Strip	1

Assembly Instructions



Item #211-4750 Model # M24WC
Item #211-4751 Model # M24WCTB
Item #211-4752 Model # M24WCTR
Item #211-4753 Model # M24WCW

USE AND CARE GUIDE

24 IN Wall Cabinet

Questions, problems, missing parts?
Before returning to the store, call
1-866-441-5080
9 a.m – 5 p.m., CST, Monday-Friday



Table of Contents

Table of Contents.....	2	Assembly	5-7
Safety Information	2	Maintenance.....	8
Warranty.....	3	Replacement Parts	8
Specifications	3		
Package Contents.....	3-4		

Safety Information

To reduce the risk of injury, please read and follow the safety instructions below before assembling and using this product.

1. This product is not designed for commercial or industrial storage.
2. This product is intended for indoor use only.
3. Do not alter this product in any manner. For example, do not weld external lock bars or attach electrical equipment.



CAUTION: Do not attach or mount this product to a vehicle or mobile trailers. This may cause personal injury or product damage. Mounting this product to any vehicle or mobile trailers in any manner will void warranty.



CAUTION: Do not stand on this product. You may fall which may cause personal injury or product damage.



CAUTION: Keep the product on level surfaces. The product may become unstable and tip if stored or moved on an unlevel surface, which may cause personal injury or product damage.



CAUTION: Lock the door if moving this product. The doors could come open and make the product unstable and tip, which may cause personal or product damage.



CAUTION: Failure to securely mount the wall bracket into the wall studs may result in the cabinet falling off the wall, which may cause personal injury or product damage.

Limited Lifetime Warranty

PERFORMAX® wall cabinets are warranted to be free from defects in materials and workmanship under normal use for the lifetime that you own the product. If any part of the product is found to be defective during normal use, the defective product or part will be replaced at our discretion. This warranty does not cover products that are damaged through accident, abuse, misuse, commercial/industrial applications or neglect. This warranty also does not cover any losses, injuries or costs including indirect, incidental or consequential damages. This warranty may not be transferred or sold. When requesting warranty service please call 1-866-441-5080 and have the model number, cash register receipt and the date of purchase available when you call. If the product is defective, we will replace the defective part at no cost to you. Some states do not allow the exclusion or limitation of incidental damages, so the above limitations or exclusions may not apply to you. This warranty gives you specific legal rights and you may have other rights, which vary from state to state.

Specifications

Maximum Load Capacity (per shelf)	100 lbs.
--	----------

 **NOTE:** Begin product assembly close to the final intended location of your cabinet. This product is heavy and may be difficult to move after assembly.

Package Contents

HARDWARE INCLUDED

 **NOTE:** Hardware not shown to actual size.

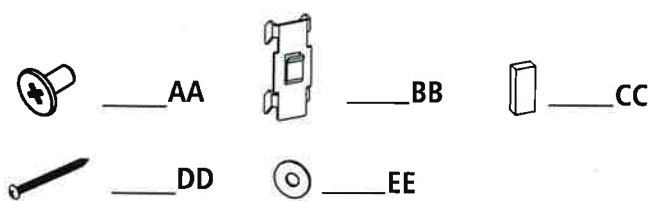

Part	Description	Quantity
AA	M6x10 Screw	40
BB	Shelf Mount	4
CC	EVA Bumper	2
DD	ST6.3x75 screw	3
EE	Washer	3

ALTERNATIVE TOOLS FOR ASSEMBLY (Not Included)

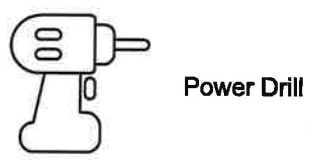

Package Contents (continued)

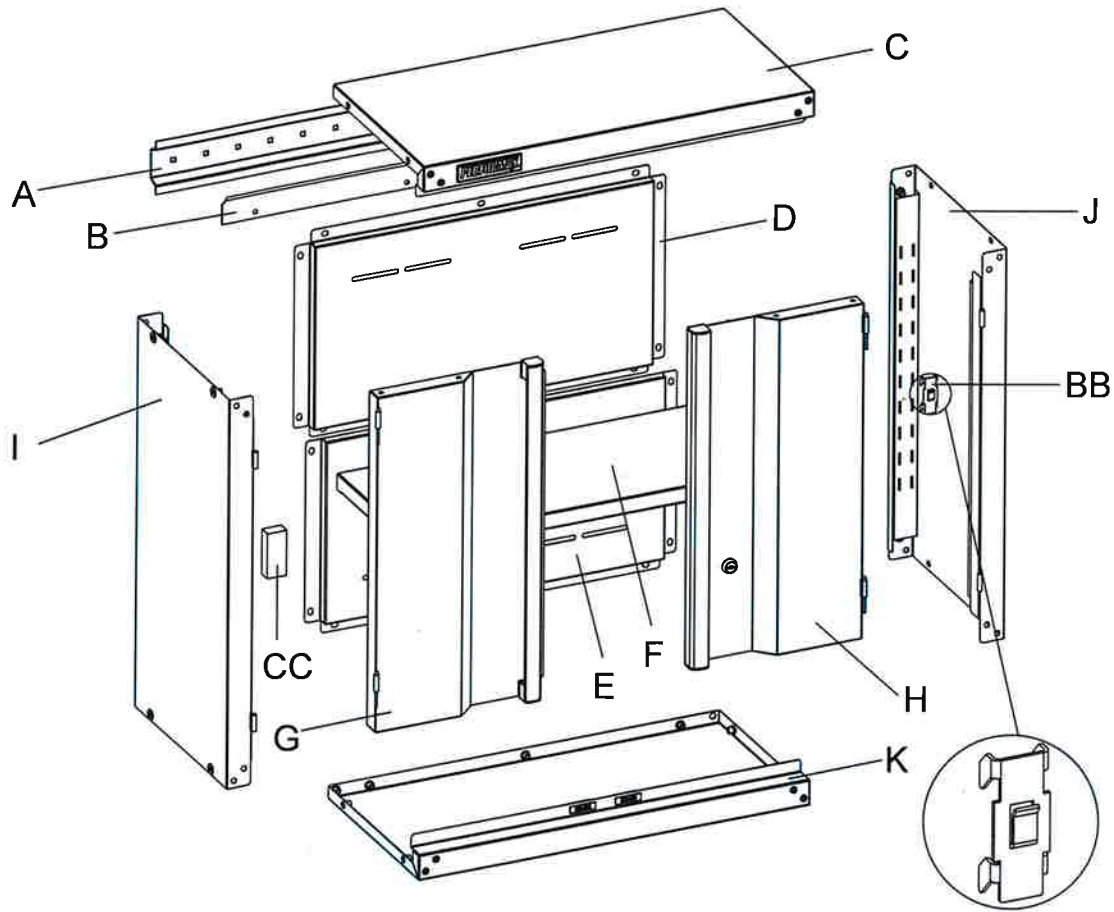

Part	Description	Quantity	Part	Description	Quantity
A	Wall Bracket	1	G	Left Door	1
B	Hanger	1	H	Right Door	1
C	Top Panel	1	I	Left Side Plate	1
D	Back Panel-top	1	J	Right Side Plate	1
E	Back Panel-bottom	1	K	Bottom Panel	1
F	Adjustable Shelf	1			

Assembly



CAUTION: Two people are recommended for assembly.

1 Unpacking instructions

- Remove all parts and hardware from the shipping box. Check the contents against the PARTS and HARDWARE lists on the previous page. If parts or hardware are missing, please call 1-866-441-5080 for assistance.
- To assure the squareness of the unit, do not fully tighten the screws until the cabinet is fully assembled and level.

2 Attaching the Side Panel

- Attach Left Side Panel (I) and Right Side Panel (J) to Bottom Panel (K) with 10 Screws (AA).
- Do not fully tighten.

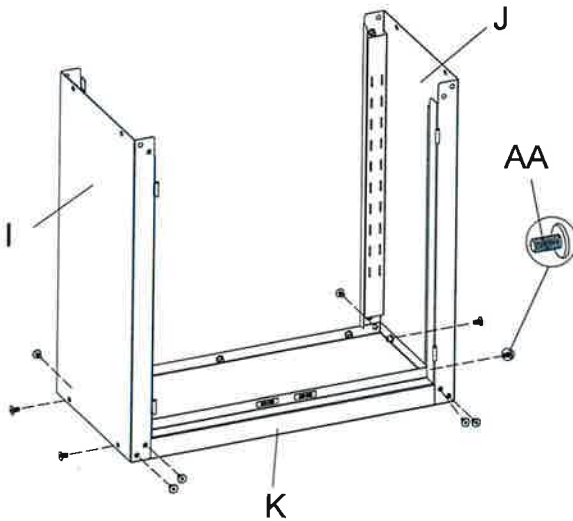

3 Attaching the Top Panel

- Attach Top Panel (C) to the Side Panels (I,J). Align holes on the sides and back and secure with 10 Screws (AA).
- Do not fully tighten.

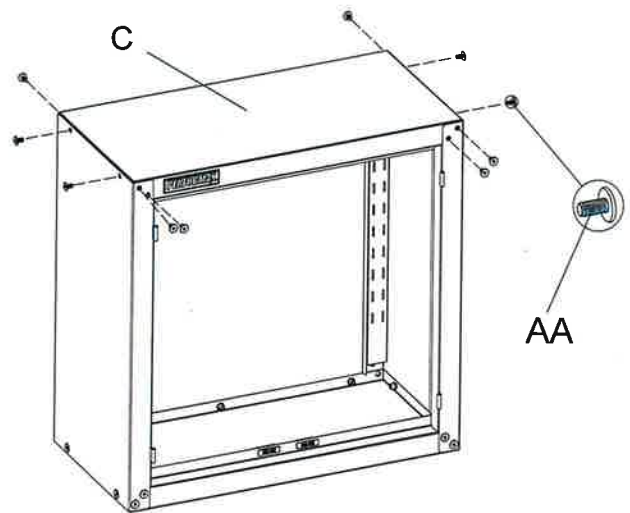

4 Attaching Back Panel

- Attach Back Panel-bottom (E) inside the two side panels and bottom. Align and insert 7 Screws (AA) into holes but do not fully tighten.
- Attach Back Panel-top (D) inside the two side panels and bottom. Align and insert 10 Screws (AA) into holes but do not fully tighten.

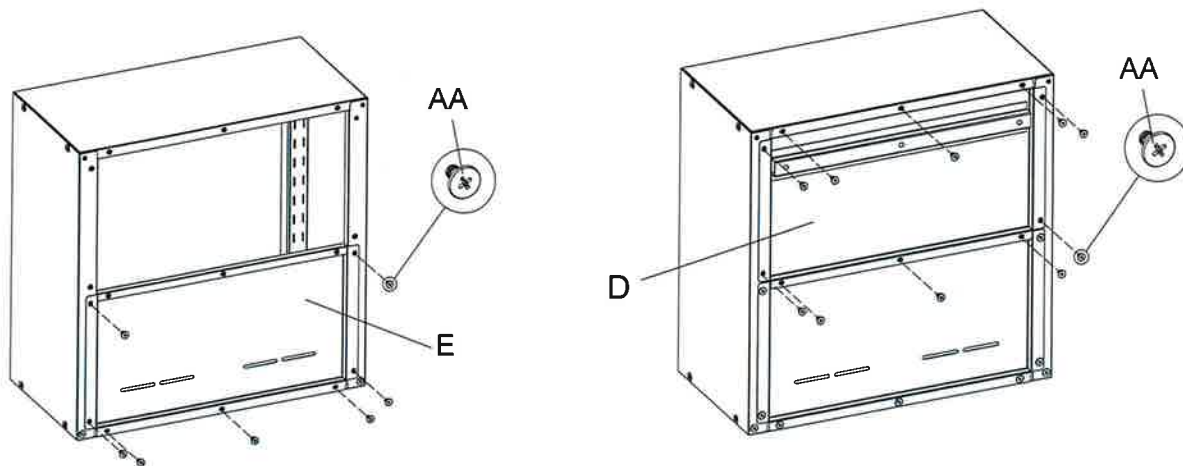

5 Attaching Hanger

- Align Hanger (B) mounting holes to the Back Panel (C) and fasten with 3 Screws (AA).

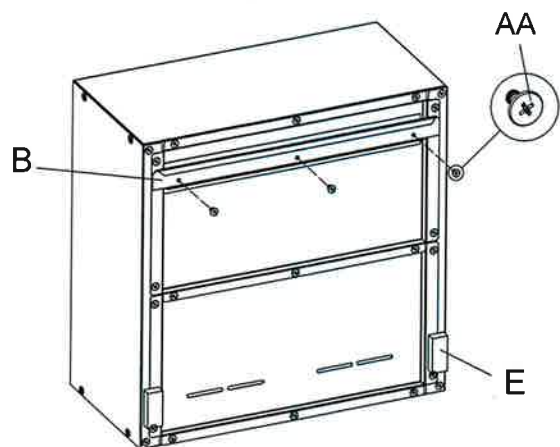

6 Attaching Adjustable Shelf

- Determine the desired height of your shelf.
- Attach and install the 4 Shelf Mounts (BB) to the front and rear corners.
- Insert Adjustable Shelf (F) into cabinet.

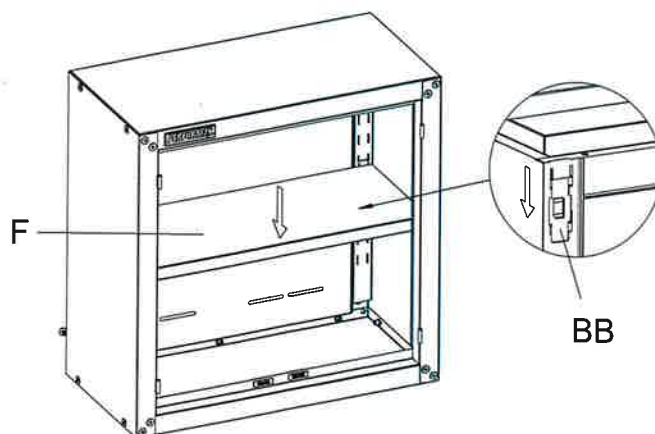

6 Attaching the door

- Align the holes on the hinge of the Left Door (G) to the holes on the Side Panel.
- Repeat process for the Right Door (H with lock assembly).
- Once cabinet is square and level, go back and tighten all screws used in assembly.

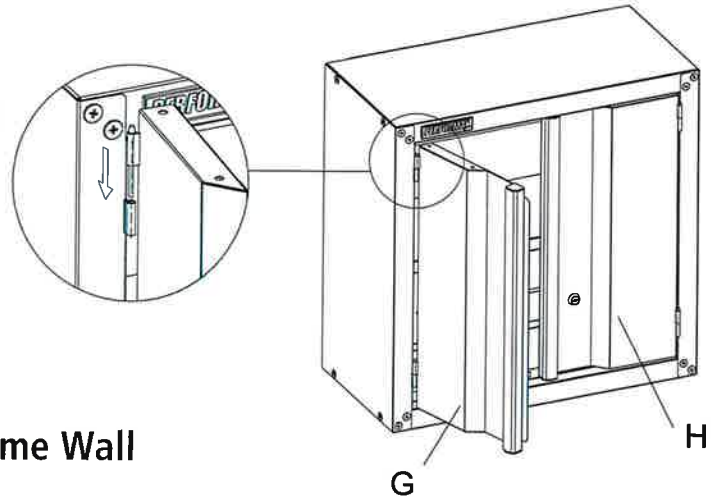

7 Hanging Cabinet on Wood Frame Wall

When hanging the wall cabinet with supplied wall bracket, be sure the bracket is level and secured to a minimum of 2 wall studs with supplied fasteners. If attaching to masonry, use appropriate masonry fasteners. Failure to do so may cause the wall cabinet to fall.

- **Step 1: EVA assembly**
Peel off the paper back from the 2 EVA Bumpers (CC), and affix in the appropriate position toward bottom of Wall Cabinet back.
NOTE: Wall cabinet may need to be hung in the desired location to determine the appropriate position for EVA.
- **Step 2 Attaching Wall bracket**
Measure and mark the location of the holes on the wall into a minimum of 2 wall studs.
Ensure the bracket is level.
Use the ST6.3x75 Screws (DD) and Washers (EE) to attached Bracket (C) into the wall studs.
- **Step 3: Hang Wall Cabinet**
Once the Wall bracket is secure, hang Wall Cabinet and ensure attachment is secure and level.

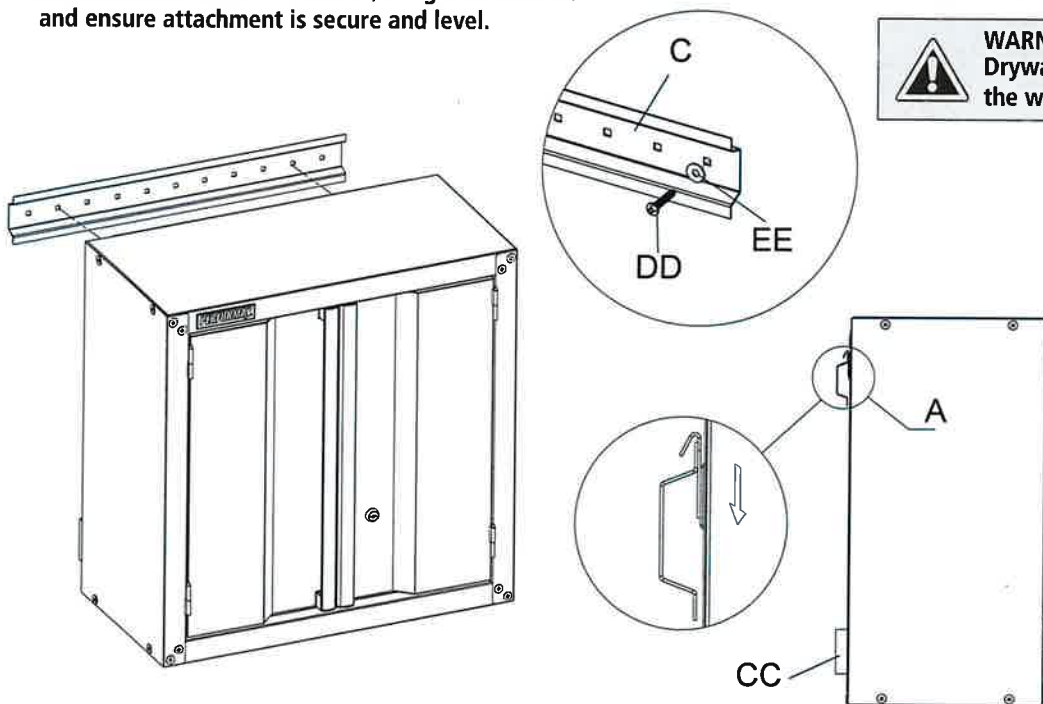

Maintenance

- Periodically the surfaces should be cleaned with a mild detergent and water.

Replacement Parts

For assistance with replacement parts please call 1-866-441-5080.

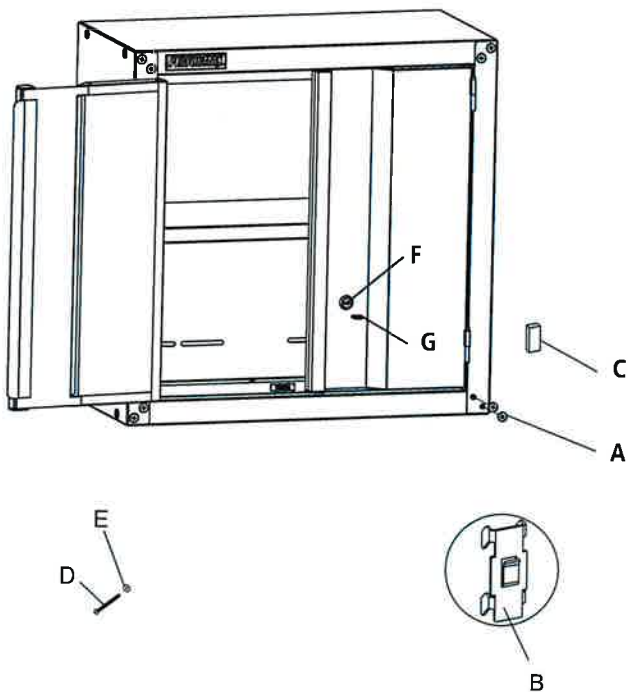

Part	Description	Quantity
A	M6x10 Screw	40
B	Shelf Mount	4
C	EVA Bumper	2
D	ST6.3x75 screw	3
E	Washer	3
F	Lock	1
G	Key	2

Assembly Instructions



Item #211-4774 Model # M36FC
Item #211-4775 Model # M36FCTB
Item #211-4776 Model # M36FCTR
Item #211-4777 Model # M36FCW

USE AND CARE GUIDE

36 IN Tall Storage Cabinet

Questions, problems, missing parts?
Before returning to the store, call
1-866-441-5080
9 a.m – 5 p.m., CST, Monday-Friday

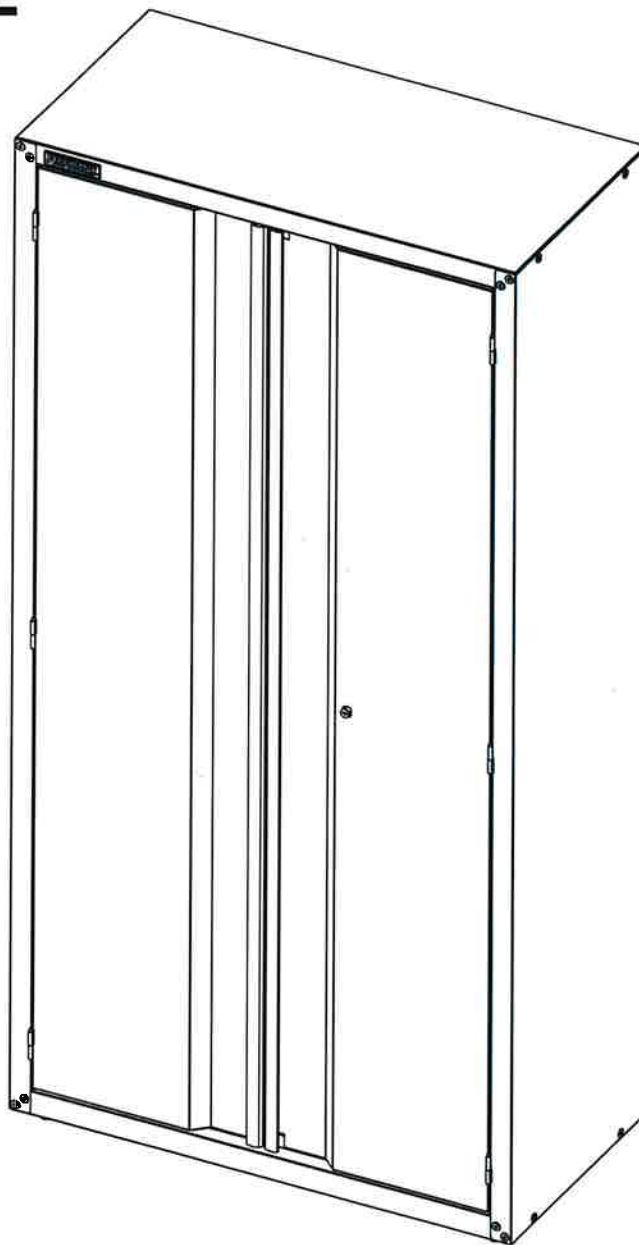

Table of Contents

Table of Contents.....	2	Assembly	5-7
Safety Information	2	Maintenance.....	8
Warranty.....	3	Replacement Parts	8
Specifications	3		
Package Contents.....	3-4		

Safety Information

To reduce the risk of injury, please read and follow the safety instructions below before assembling and using this product.

1. This product is not designed for commercial or industrial storage.
2. This product is intended for indoor use only.
3. Do not alter this product in any manner. For example, do not weld external lock bars or attach electrical equipment.



CAUTION: Do not attach or mount this product to a vehicle or mobile trailers. This may cause personal injury or product damage. Mounting this product to any vehicle or mobile trailers in any manner will void warranty.



CAUTION: Do not stand on this product. You may fall which may cause personal injury or product damage.



CAUTION: Keep the product on level surfaces. The product may become unstable and tip if stored or moved on an unlevel surface, which may cause personal injury or product damage.



CAUTION: Lock the door if moving this product. The doors could come open and make the product unstable and tip, which may cause personal or product damage.



CAUTION: It is recommended to secure this product to the wall to prevent accidental tipping.

Limited Lifetime Warranty

PERFORMAX® tall cabinets are warranted to be free from defects in materials and workmanship under normal use for the lifetime that you own the product. If any part of the product is found to be defective during normal use, the defective product or part will be replaced at our discretion. This warranty does not cover products that are damaged through accident, abuse, misuse, commercial/industrial applications or neglect. This warranty also does not cover any losses, injuries or costs including indirect, incidental or consequential damages. This warranty may not be transferred or sold. When requesting warranty service please call 1-866-441-5080 and have the model number, cash register receipt and the date of purchase available when you call. If the product is defective, we will replace the defective part at no cost to you. Some states do not allow the exclusion or limitation of incidental damages, so the above limitations or exclusions may not apply to you. This warranty gives you specific legal rights and you may have other rights, which vary from state to state.

Specifications

Maximum Load Capacity (per shelf)	150 lbs.
-----------------------------------	----------

 **NOTE:** Begin product assembly close to the final intended location of your cabinet. This product is heavy and may be difficult to move after assembly.

Package Contents

HARDWARE INCLUDED

 **NOTE:** Hardware not shown to actual size.

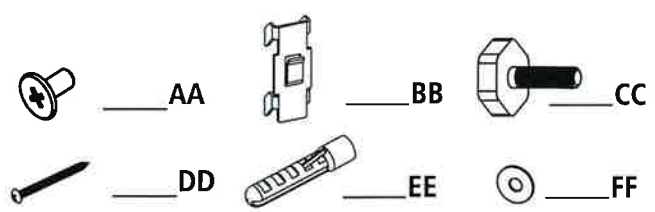

Part	Description	Quantity
AA	M6x10 Screw	51
BB	Shelf Mount	12
CC	Leveling Feet	4
DD	ST6.3x75 screw	2
EE	Drywall Anchor	2
FF	Washer	2

ALTERNATIVE TOOLS FOR ASSEMBLY (Not Included)

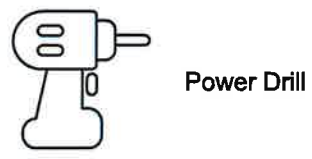

Package Contents (continued)

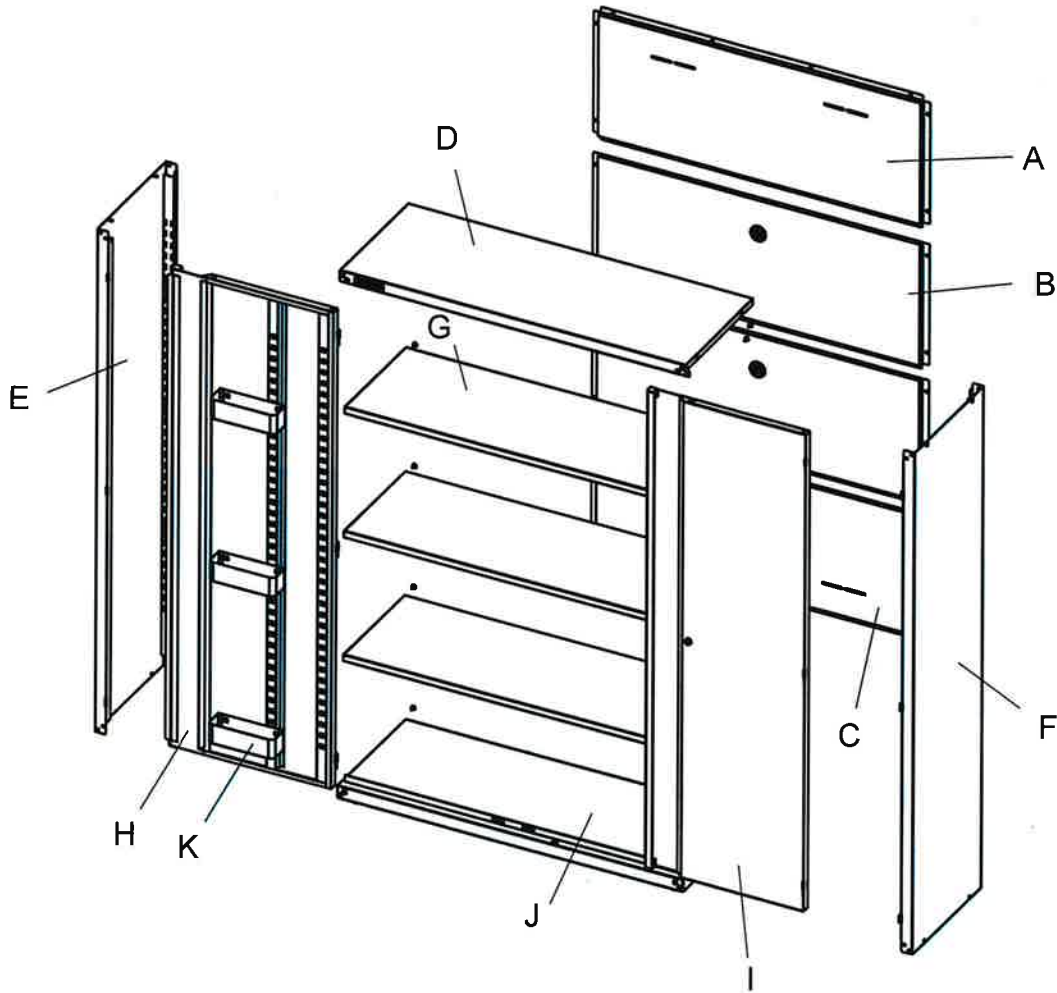

Part	Description	Quantity	Part	Description	Quantity
A	Back Panel-top	1	F	Right Side Plate	1
B	Back Panel-middle	2	G	Adjustable Shelf	3
C	Back Panel-bottom	1	H	Left Door	1
D	Top Panel	1	I	Right Door	1
E	Left Side Plate	1	J	Bottom Panel	1
			K	Storage Tray	6

Assembly



CAUTION: Two people are recommended for assembly.

1 Unpacking instructions

- Remove all parts and hardware from the shipping box. Check the contents against the PARTS and HARDWARE lists on the previous page. If parts or hardware are missing, please call 1-866-441-5080 for assistance.
- To assure the squareness of the unit, do not fully tighten the screws until the cabinet is fully assembled and level.

2 Attaching the Leveling Feet

- Attach the Leveling Feet (CC) to Bottom Panel (J) and tighten.

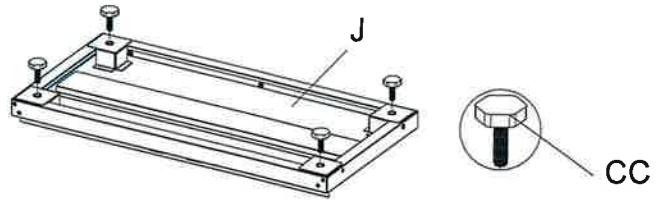

3 Attaching the Side Panels

- Attach Left Side Panel (E) and Right Side Panel (F) to Bottom Panel (J) with 10 screws (AA).
- Do not fully tighten.

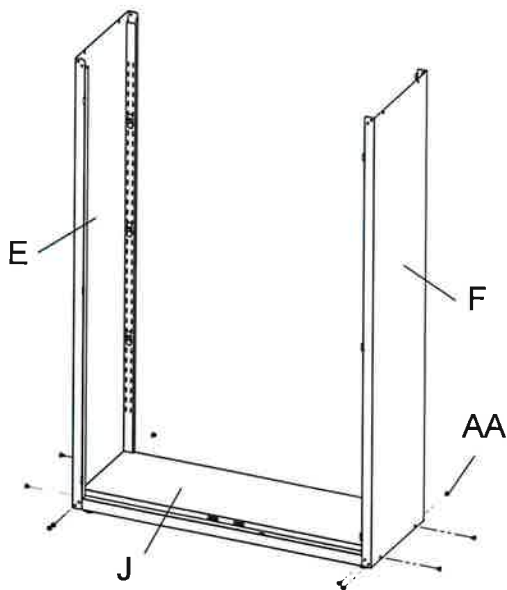

4 Attaching the Top Panel

- Attach Top Panel (D) to the Side Panels (E) and (F). Align holes on the sides and back and secure with 10 screws (AA).
- Do not fully tighten.

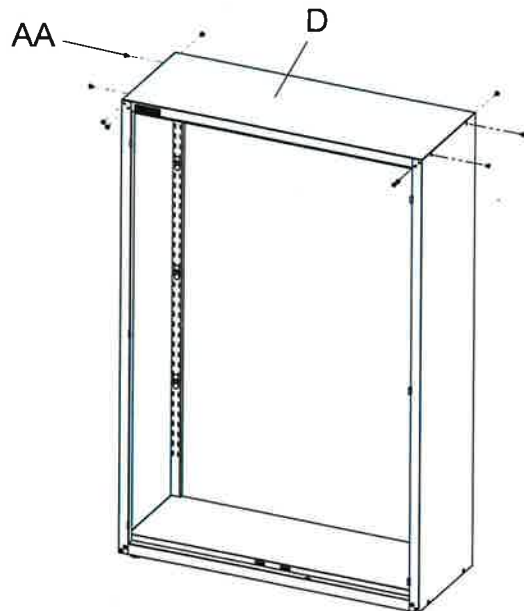

5 Attaching Back Panel

- Attach Back Panel-bottom (C) inside the two side panels and bottom. Align and insert 7 screws (AA) into holes but do not fully tighten.
- Attach the two Back Panel-middle (B) inside the two side panels and bottom. Align and insert 14 screws (AA) into holes but do not fully tighten.
- Attach Back Panel-Top (A) inside the two side panels and bottom. Align and insert 10 screws (AA) into holes but do not fully tighten.

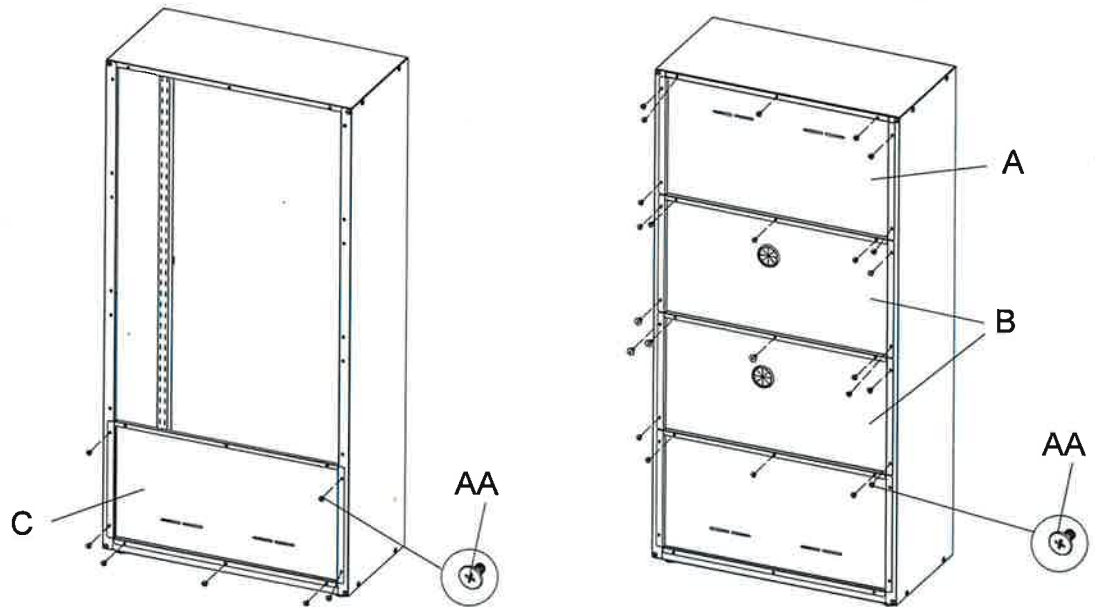

6 Attaching Adjustable Shelf

- Determine the desired height of your shelf.
- Attach and install four of the Shelf Mounts (BB) for each shelf to the front and rear corners.
- Insert Adjustable Shelf (G) into cabinet.

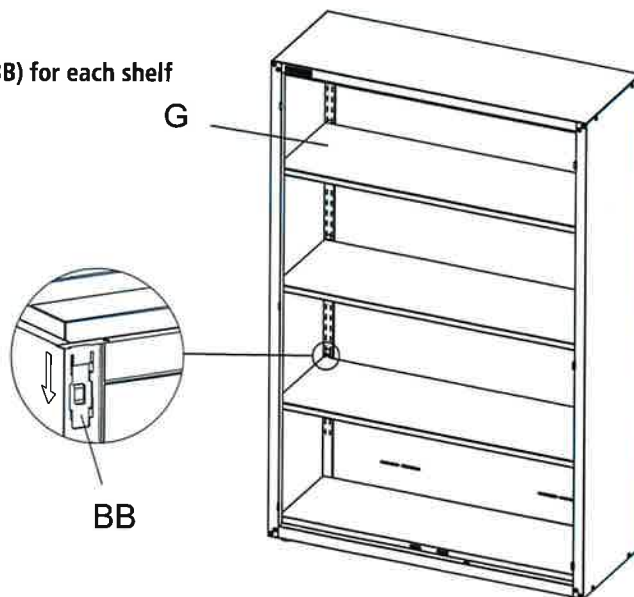

7 Attaching the door

- Align the holes on the hinge of the Left Door (H) to the holes on the Side Panel.
 - Repeat process for the right door (I with lock assembly).
- Note: To maintain proper operation of the cabinet doors, ensure the cabinet is completely level by adjusting the four Leveling Feet (CC).
- Once cabinet is square and level, go back and tighten all screws used in assembly.

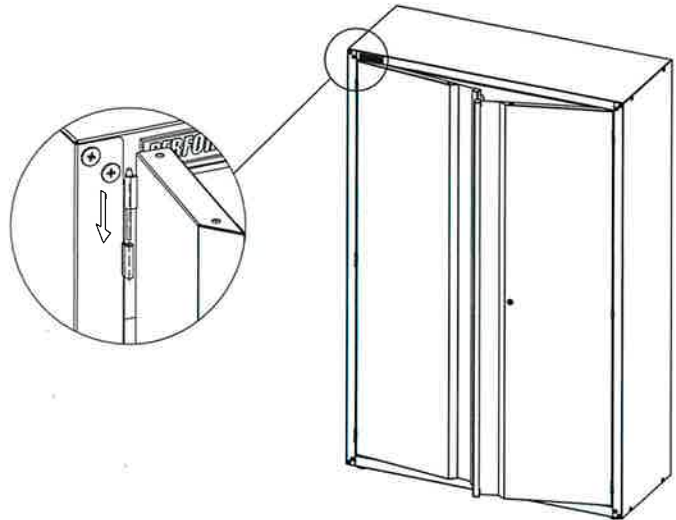

8 Securing to a Wall

- Measure and mark the location of the left and right attachment holes on the wall.
- Drill a 5/16" hole on the left and right side and insert the Drywall Anchor (EE) into the holes. Use the ST6.3x75 screw (DD) and washer (FF) to secure each side of the the Back Panel (A) into the Drywall Anchor (EE).

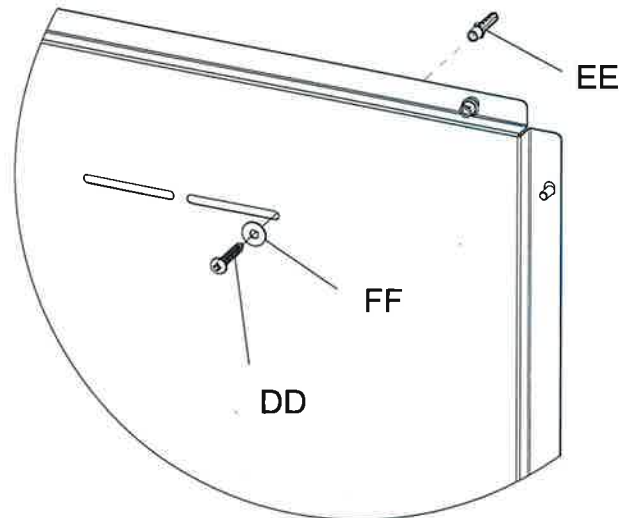
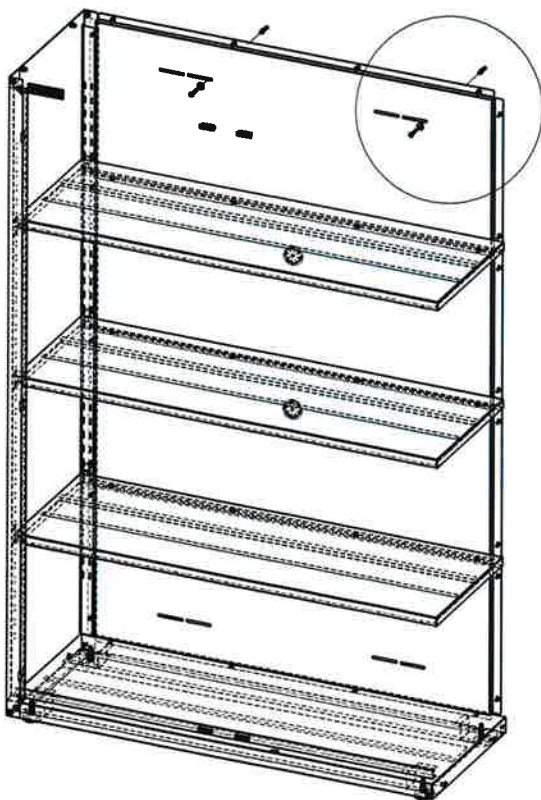

Maintenance

- Periodically the surfaces should be cleaned with a mild detergent and water.

Replacement Parts

For assistance with replacement parts please call 1-866-441-5080.

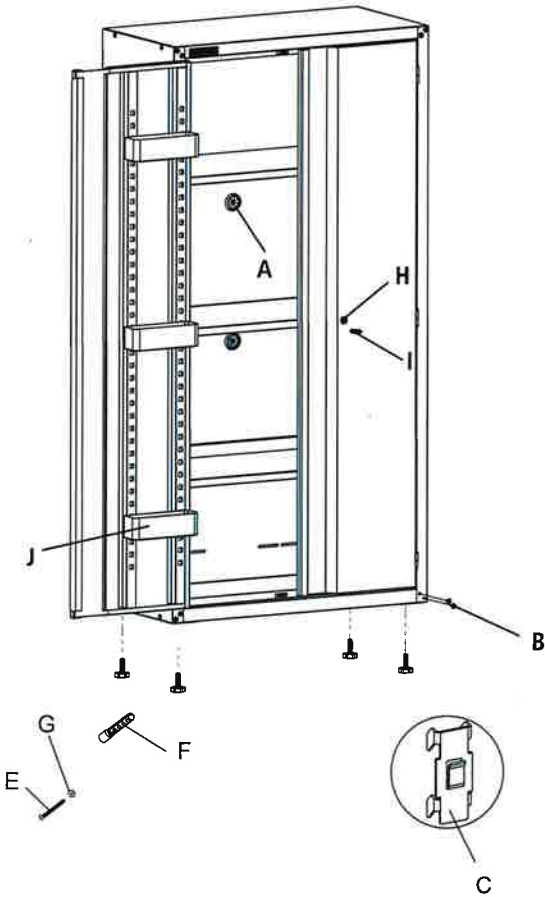

Part	Description	Quantity
A	Rubber grommet	2
B	M6x10 Screw	51
C	Shelf Mount	12
D	Leveling Feet	4
E	ST6.3x75 screw	2
F	Drywall Anchor	2
G	Washer	2
H	Lock	1
I	Key	2
J	Storage Tray	6