



MULTI GRILL & GRIDDLE **USER GUIDE**

IMPORTANT SAFEGUARDS

When using an electrical appliance, basic safety precautions should always be followed, including the following:

1. **IMPORTANT:** Read all instructions carefully before first use.
2. Do not touch hot surface. The metal housing will become hot during use. Use handle only.
3. **CAUTION:** To reduce the risk of electric shock, cook only on removable plates.
4. Use tongs or other heat safe utensils to remove food. Do not lift appliance.
5. Close supervision is necessary when any appliance is used by or near children.
6. To protect against electrical shock, do not immerse cord, plug, or cooker body in water or other liquid.
7. Unplug from outlet when not in use and before cleaning. Allow to cool before putting on or taking off parts, and before cleaning the appliance.
8. Do not operate any appliance with a damaged cord or plug or after the appliance malfunctions or has been damaged in any manner. Return appliance to the nearest authorized service facility for examination, repair, or adjustment.
9. The use of accessory attachments not recommended by the appliance manufacturer may cause injuries.
10. Intended for countertop use only as directed. Not for stovetop use.
11. Do not use the appliance for other than intended use.
12. Do not use outdoors.
13. Do not let cord touch hot surfaces or hang over the edge of table or counter.
14. **WARNING:** Spilled food can cause serious burns. Keep appliance and cord away from children. Never drape cord over edge of counter, never use outlet below counter, and never use with an extension cord.
15. Prior to first use, please make sure that the electrical rating of the appliance is in conformity with the current electric rating.
16. Plug cord into wall outlet. To disconnect, switch appliance off, then remove plug from wall outlet.
17. To reduce the risk of electric shock, cook only in removable container. DO NOT cook food directly in the unit base.
18. DO NOT place on or near a hot gas or electric burner, or in a heated oven.
19. SAVE THESE INSTRUCTIONS Do not throw away. Read before operating your new Contact Grill & Griddle. Keep for future reference.
20. In order to ensure safe operation and optimum performance, please read the entire Instruction/Care & Use Booklet.
21. Extreme caution must be used when moving an appliance containing hot oil or other hot liquids.
22. To disconnect, turn the unit off, then remove the plug from the wall outlet.

SAVE THESE INSTRUCTIONS FOR HOUSEHOLD USE ONLY

SPECIAL CORD SET INSTRUCTIONS:

A short power-supply cord is provided to reduce the risks resulting from becoming entangled in or tripping over a longer cord. Longer extension cords may be used if care is exercised. If a long extension cord is used, the marked electrical rating of the extension cord should be at least as great as the electrical rating of the appliance, and the longer cord should be arranged so that it will not drape over the countertop or tabletop where it can be pulled on by children or animals or tripped over.

HEALTHY COOKING STARTS WITH GREENPAN

Since pioneering healthy ceramic nonstick in 2007, we've dedicated ourselves to unique advances that make cooking better for everyone. From healthy ceramic nonstick cookware to revolutionary home appliances, our groundbreaking designs deliver remarkable performance so you can focus on the flavor. **Enjoy!**

CONTENTS

04	What's Included	10	Cooking Guide
05	Important Tips	11	Cleaning & Maintenance
06	Instructions for Use	12	Troubleshooting
08	Cooking Positions	14	Warranty
09	Cooking Tips		

WHAT'S INCLUDED

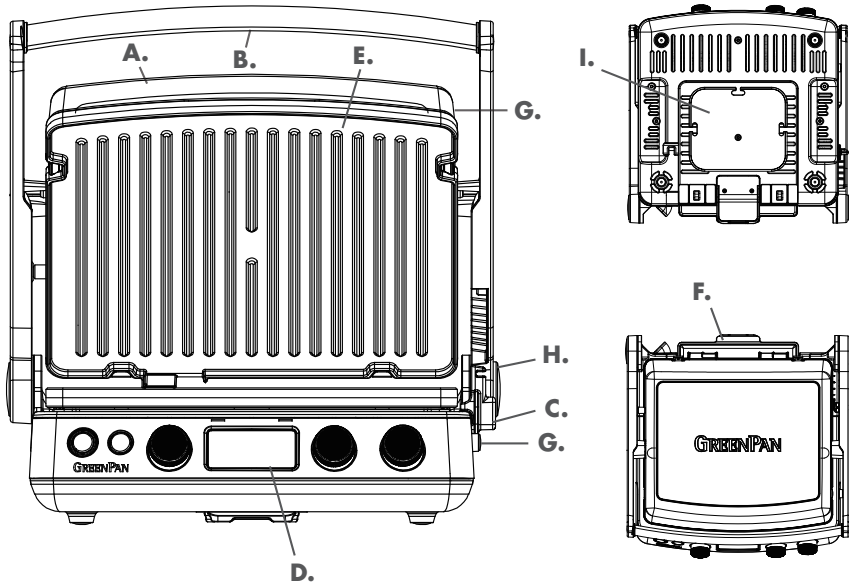

A. Base & Cover

Solid construction with a stainless steel design and self-adjusting cover.

B. Handle

Panini-style handle to help adjust cover to accommodate thickness of food.

C. Adjustable Height Settings & Locking Mechanism

Features preset height positions for melting. Locks cover closed to store.

D. Control Panel

Start/stop and sear buttons; dial controls and LCD display screen.

E. Reversible Grill/Griddle Plates

Removable and reversible Thermolon™ Volt Ceramic Nonstick Plates.

F. Drip Tray

Collects grease and removes from base for easy cleanup.

G. Plate Release Buttons

Push in to release and remove cooking plates.

H. Hinge Release Button

Allows cover to extend back to the Flat Position.

I. Cord Storage

Conveniently located underneath to hide away the cord.

NOTE: DO NOT ATTEMPT TO PICK UP MULTI GRILL & GRIDDLE FROM HANDLE. THIS IS NOT INTENDED FOR CARRYING. PLEASE PICK UP FROM THE BASE OF THE UNIT.

IMPORTANT TIPS

BEFORE FIRST USE

1. Read all instructions and important safeguards.
2. Remove all packaging materials and check that all items have been received in good condition.
3. Tear up all plastic bags and dispose of properly as they can pose a suffocation or choking risk to children.
4. Wipe body clean with a damp cloth.

NOTE: Do not use harsh abrasive cleaners, scouring pads or products that are not considered safe to use on nonstick coatings. If washing in the dishwasher, a slight discoloration to the plates and accessories may occur. This is cosmetic only and will not affect performance. THIS APPLIANCE IS FOR HOUSEHOLD USE ONLY.

5. Thoroughly clean the ceramic nonstick plates and drip tray. The ceramic nonstick plates and drip tray are dishwasher safe.

KNOW YOUR CONTROL PANEL



START/STOP BUTTON: Press to power on the unit, start the preheating cycle, pause, or continue the cooking cycle.

SEAR: Instantly get max power to get the perfect finish.

TIME: Dial in the perfect time for your meal.

PLATE SELECT: Select the plate or plates for your task—upper, lower, both, or waffle (waffle plates sold separately).

TEMP/SHADE: Adjust the temperature or waffle shade (waffle plates sold separately).

INSTRUCTIONS FOR USE

OPERATION

Once your Multi Grill & Griddle is properly assembled, plug the cord into a standard electrical outlet and you will be ready to get cooking. The LCD will illuminate, after any button or dial is selected, but no cooking function is selected yet. To turn on the product for function selection, press the Start/Stop button.

Put your Multi Grill & Griddle in the preferred cooking position and use the temperature control to choose your cooking temperature. Settings range from Low (175°F) to High (450°F). If you wish to use the Multi Grill & Griddle in the flat position but you do not need the entire surface, it is recommended that you use the bottom plate.

NOTE: To change the temperature between °C and °F, press and hold the START/STOP button and SEAR button simultaneously for 6 seconds.

SELECTING PLATES & TEMPERATURE

- To start using your Multi Grill & Griddle turn the plate select dial to select which plate(s) you need to adjust the settings for.
- Select "Lower" or "Upper" if you want to select a different temperature for each plate. Select "Both" if want to adjust the setting of both plates simultaneously.
- Default timer and temperature will appear on the LCD display.
- Turn the dial to adjust your temperature.
- To adjust your countdown timer, turn the dial to select the number of minutes.
- Press the start button, and you will notice the LCD screen will display "PREHEAT" and bars running from left to right.
- Once it's done preheating, it will beep three times and the "PREHEAT" disappears and the minutes will start blinking.
- Press start to start the timer counting down and add your food to the plate(s).

NOTE: You can select a continuous "ON" mode; however, the unit has a 60-minute auto-shutoff feature. Turn the power back on if more time is needed.

- When the countdown timer runs out, the Multi Grill & Griddle will beep three times. The time will reset to the previously selected values and will start flashing to indicate that it's ready to start the next cycle.
- To stop cooking, select the plate to turn off, then turn the temperature dial to beyond minimum value, "OFF" will display for the selected plate. If both plates are during cooking or preheat, pressing Start/Stop button will turn off the product.

GETTING STARTED

INSTRUCTIONS FOR USE

DURING USE

As the Multi Grill & Griddle will become hot during use, always use caution when operating the Multi Grill & Griddle. Always use the front handle to open the Multi Grill & Griddle, as this part of the handle is designed to stay cool to the touch while cooking. The top cover will become hot during use.

DO NOT TOUCH THE COVER OR ARMS DURING OR IMMEDIATELY AFTER COOKING

The top cover should not be touched during or immediately after cooking. Use an oven mitt if you need to adjust the cover to prevent burns.

The base of the Multi Grill & Griddle will be very hot too. If you need to move the Multi Grill & Griddle for any reason allow the Multi Grill & Griddle to cool before handling (at least 30 minutes).

NOTE: During first use, the Multi Grill & Griddle may have a slight odor and it may smoke a little. This is perfectly normal and will disappear with use.

SEAR FUNCTION

You can sear foods at 500°F for up to 2 minutes. Pressing the Sear button will toggle among UPPER/LOWER/BOTH/No action. Pressing it once will have "SEAR" appear on the upper plate section. Pressing it a second time will have "SEAR" appear on the lower plate section. The third press will have "SEAR" appear on both upper and lower plate sections. Fourth press will have "SEAR" disappear on both upper and lower plate section.

WAFFLE FUNCTION

NOTE: Waffle plates sold separately.

To use your Multi Grill & Griddle to make waffles, insert both waffle plates. Select waffle plate and choose the waffle shade level from 1 to 7. The time is preset for you. After adding the batter, close the cover and press start/stop button to start cooking. You will hear 3 beeps when the waffle is done (approximately 5 to 9 minutes). Prepare the next batch or turn off.

- Allow waffle batter to rest for a few minutes before pouring onto hot Waffle Plates.
- Add a light coating of cooking oil to the plates prior to the first waffle. Do not use cooking spray or low smoke point oils.
- Waffles are best when made fresh, but can also be frozen for later use (wrap separately) and reheated in toaster or oven.
- For evenly sized waffles, pour batter into the center of the waffle plate and spread out to the edges of the plate.
- Be careful not to overfill the waffle plates.
- Always clean your Waffle Plates after each use.

COOKING POSITIONS

COOKING POSITIONS

To get started, place the GreenPan Multi Grill & Griddle on a clean, flat surface. The Multi Grill & Griddle has three different positions:

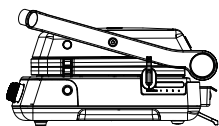

- 1. CLOSED POSITION** – Top plate/cover rests flat on lower plate/base. This is the standard starting and heating position for the Contact Griddle or Panini Press functions.

NOTE: When you unpack the Multi Grill & Griddle, the cover will be in the Locked Position. To unlock, use the slider to move to the Open Position. Please do not attempt to open the cover at any point during the operation or while the slider is in the Locked Position.

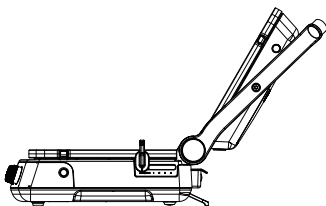

- 2. OPEN POSITION** – Top plate/cover is open. Open the cover to this position before using the Multi Grill & Griddle as a Contact Griddle or a Panini Press. To adjust the Multi Grill & Griddle into the Open Position, lift the handle until you feel it move to a steady position.

The griddle will remain in the steady position until you close the cover or move it to the Flat Open Griddle Position. The top plate/cover will stay in an upright position until you lower the handle for cooking. When you lower the handle for cooking the hinge will self-release to allow the top plate/cover to lie flat on your food and ensure total contact so your food cooks evenly.

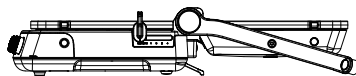

- 3. FLAT POSITION** – Top plate/cover is opened so that the top and lower plates are level and create a single cooking surface.

When opening the cover to the Flat Position, hold onto the handle, press the cover release button on the right of the unit and pull the handle back until the grill touches the countertop. Remember to put the drip tray into position to support the upper grill at the center.

INSTALLING COOKING PLATES

The Multi Grill & Griddle should be off and cooled. Put the Multi Grill & Griddle in the Flat Position.

Insert each plate individually. Find the metal holding brackets at the center of the housing. Tilt the back end of the plate and line up the cutouts with the metal brackets. Slide the plate beneath the brackets and push down on the front end of the plate. You should hear it snap into place. Turn the Multi Grill & Griddle 180° and install the second plate into the upper housing the same way.

REMOVING COOKING PLATES

The Multi Grill & Griddle should be off and cooled.

Put your Multi Grill & Griddle in the Flat Position. Find the plate release buttons on one side. Press one button firmly and the cooking plate will pop up from the base. Grab the cooking plate with both hands, slide it from under the metal brackets and lift from the base. Press on the other button to release the other cooking plate the same way.

WAYS TO COOK

COOKING TIPS

EXPLORE NEW CULINARY TERRITORY

The Multi Grill & Griddle delivers ultimate versatility with many different cooking modes. Use it as a Contact Grill, Contact Griddle, Panini Press, Open Grill, or Open Griddle, or grill on one side and griddle on the other.

Keep Multi Grill & Griddle closed while preheating and wait until preheat mode is complete.

CONTACT GRIDDLE (CLOSED POSITION)

Perfect for sausages, boneless chicken and veggies, the Contact Griddle saves time because you're griddling both sides of your food at once.

NOTE: Keeping your food to the same thickness will ensure it all cooks evenly in Closed Positions.

CONTACT GRILL (CLOSED POSITION)

Get classic sear marks faster with the Closed Grill Position. That means faster burgers, steaks, pork chops, and so much more.

PANINI PRESS (CLOSED POSITION)

Crispy paninis and wraps are easy with the Multi Grill & Griddle. You can apply light pressure to the handle to press your food to your liking.

FLAT GRILL (OPEN POSITION)

Bring outdoor flavor inside with the Flat Grill Position. Just open the cover flat against the counter. This position utilizes two grill plates to deliver a

full-sized healthy ceramic nonstick grill.

FLAT GRIDDLE (OPEN POSITION)

Flat Griddle refers to using both griddle plates with the cover flat against the counter to create a spacious flat top cooking surface. This setting is perfect for a huge array of options, including classics like french toast and pancakes to everyday cooking like chicken and veggies.

MIXED GRILL & GRIDDLE (OPEN POSITION)

Mix it up for your meal with both grill and griddle plates in the Open Position. Grill breakfast sausage and make eggs at the same time, grill meats while searing veggies, fish and chips, fajitas...the options are endless.

COOKING GUIDE

Food	Plate	Open/ Closed	Suggested Temp & Time
Bacon	Grill or Griddle	Open	Place bacon on cold plates. Turn to 450°F. Cook until desired crispiness. Should take about 15 mins for 1 lb. of bacon (using the Flat Position).
Beef, Boneless Steak	Grill	Both	When cooking in the Closed Position, preheat to SEAR. Put the steaks on the preheated lower grill plate. Using the adjustable hinge, set the upper plate so it's just touching the steak, but not pressing it. Sear for 2 mins, then the grill will reset to 450°F. Cook for 2 to 5 mins depending on the thickness of the steak and desired doneness. When using the Open or Flat Positions, preheat to 450°F. Put the steaks on the preheated grill plates. Cook for about 4 to 6 mins per side, depending on the thickness of the steaks and desired doneness.
Chicken Breast	Grill	Both	When cooking in the Closed Position, preheat to 400°F. Cook for 7 to 9 mins in the Closed Position, or 8 to 10 mins per side in the Flat Position. (Internal temperature should be 175°F—juices will run clear with no signs of pink.)
Fish Steaks	Grill	Both	400°F, 6 to 7½ mins when grilling in the Closed Position. 7 to 8 mins per side in the Flat Position.
Hamburgers	Grill	Closed	450°F. Put the burgers on the preheated lower grill plate. Using the adjustable hinge, set the upper plate so it's just touching the burgers, but not pressing it.
Sausages (uncooked)	Grill or Griddle	Both	450°F. Put the links on the preheated grill/griddle plates—the grill ribs are perfect for holding the links in place and allow for easy turning for even cooking. Grill for about 5 mins per side in the Open Position or about 12 mins (turning halfway through) in the Closed Position, depending on the thickness of the sausages.
Panini	Grill or Griddle	Closed	Preheat both plates to 350°F. Put the prepared sandwiches on the preheated lower grill/griddle plates. Close the top. Cook sandwiches for about 4 to 6 mins depending on the thickness of sandwiches
Open-Faced Sandwiches	Grill or Griddle	Closed	Preheat lower plate to 350°F, upper plate to 450°F. Put the prepared sandwiches on the preheated lower grill/griddle plate. Using the cover height adjuster, close the upper plate until it is sitting right above the top of the sandwich, not touching it. Cook sandwich and cheese on top is fully melted and lightly browned.
Quesadillas	Grill or Griddle	Closed	Preheat both plates to 400°F. Put the prepared quesadilla on the preheated lower plate. Close the top and using the cover height adjuster, set the upper plate so it is just sitting on top of the quesadillas. Grill for about 2 to 3 mins, depending on the thickness and filling of the quesadillas.
Eggs	Griddle	Open	350°F. Break the eggs onto the hot griddle plates. Flip once whites are set, about 2 to 3½ mins, and remove when cooked to desired doneness.
French Toast	Griddle	Open	350°F. Flip after 2 to 3 mins, depending on thickness. Cook for an additional 2 to 3 mins.
Vegetables	Grill	Both	400°F. Grill until tender. This will vary depending on the types of vegetables used, but should take between 20 and 30 mins.
Pizza	Grill	Closed	Grill dough on SEAR with the unit closed. Then let the temperature revert to 450°F. Open to add toppings and using the cover height adjuster, close the upper plate until it's sitting above the top of the pizza, but not touching it. Cook until cheese/toppings are melted and browned, 10 to 15 mins.

NOTE: These are suggested times only and may vary based on ingredients, temperatures, and personal preference. Always check internal meat temperatures with a food thermometer for safety.

CLEANING & MAINTENANCE

USER MAINTENANCE

- While your plates are metal utensil safe, we recommend using plastic, silicone, or wooden utensils to prolong the life of your ceramic nonstick plates.
- Never leave plastic utensils in contact with the hot plates.
- Between meals, wipe off food buildup through grease channels and into the drip tray. Remove any residue with a paper towel before starting your next meal.
- Allow the Multi Grill & Griddle to cool completely (at least 30 minutes) before cleaning.

CLEANING & MAINTENANCE

Before cleaning, always unplug your Multi Grill & Griddle and allow it to cool. Remove and dispose of grease and fats that have accumulated in the drip tray.

Press the plate release buttons to remove the plates for cleaning. Make sure the cooking plates have cooled completely before handling (at least 30 minutes). Cooking plates are dishwasher safe. Do not scrape the cooking plates with metallic objects like knives or forks and do not use a scouring pad for cleaning. Doing so can damage the plates' ceramic nonstick coating.

If you've cooked seafood with the Multi Grill & Griddle, wipe the cooking plate with lemon juice to avoid transferring seafood flavor to your next meal. The base, cover and control knob can be wiped clean with a soft, dry cloth. For tougher messes, dampen cloth.

See below table for cleaning guidance. Refrain from using scouring pads, powders, or chemical detergents.

Part	Dishwasher & Hand wash safe	Wipe with damp cloth
Splash Guard		✓
Base		✓
Interchangeable Grill/Griddle Plates	✓	
Drip Trays	✓	

STORAGE

Ensure the Multi Grill & Griddle is cool and dry before storing. Wrap the power cord around the cord wrap underneath the unit. Have one set of plates assembled in the unit. Slide the height mechanism to the locked position. Store the unit either horizontally or vertically with the other set of plates nearby.

BEFORE RETURNING YOUR GREENPAN PRODUCT

If you are experiencing problems with your GreenPan Multi Grill & Griddle, we suggest that you call GreenPan customer service at 877-926-6526 before returning the product.

A representative can confirm whether the product is under warranty and advise on next steps.

TROUBLESHOOTING

Issue	Solution
Error Code: E1- E6	Contact Customer Service.
Unit does not turn on	Contact Customer Service.
Display is blank	Check the connection to the wall outlet. Press any button to wake it up. If problem persists, try using a different outlet.
The Start/Stop backlight is not illuminated and the display is blank	If the unit is plugged in, the Start/Stop backlight should be illuminated. If problem persists, try using a different outlet. Please note, timer does not begin to count down until you press the Start/Stop button to start timer.
I do not know when preheat is complete	The unit will beep three times, the "PREHEAT" will disappear from the display, and the minutes will start blinking.
The unit shut off	Be sure to hit start after preheating is complete.
Cover is not opening	To unlock, move the slider to the Open Position.
Unable to lay unit to Flat Position	Hold onto the handle and press the cover release button on the right of the unit and pull the handle back until the grill touches the countertop. Remember to put the drip tray into position to support the upper grill at the center.
Difficulties removing plates	Press the release buttons on the sides.
Difficulties inserting plates	Find the metal holding brackets at the center of the housing. Tilt the back end of the plate and line up the cutouts with the metal brackets. Slide the plate beneath the brackets and push down on the front end of the plate. You should hear it snap into place.
Unit turns on, but the plate(s) does not heat up	Turn the unit off and wait for it to cool. Remove and re-insert the plate(s) into proper position.
Can't turn off one of the plates	To stop cooking, select the plate to turn off, then turn the temperature dial to beyond minimum value. "OFF" will display for the selected plate.
Do I need to use the default time and temperature?	No. Use the time and temperature dials to customize your settings.
Unable to change the temperature between °C and °F	Press and hold the START/STOP button and SEAR button simultaneously for 6 seconds.

TROUBLESHOOTING

Issue	Solution
Food is overcooked/ undercooked	Decrease/increase cooking time and temperature or check C&U for an alternate mode.
Waffle Plates were not included in package	Waffle plates are available for purchase on the GreenPan website.
The grill is not closing all the way/there is a gap in the plates	Using the slider on the right, adjust the top plate to the Closed Position.
My food is getting crushed by the top plate	Using the slider on the right, adjust the top plate to the desired height.
Top plate is not getting hot	Be sure the plate selector dial is set to upper plate or both.
The bottom plate is cooking faster/hotter than the top plate	This is normal.
Bottom plate is not getting hot	Be sure the plate selector dial is set to lower plate or both.
The Sear stops after a couple of minutes	This is normal. Sear is programmed for a maximum of 2 minutes to provide that perfect finish on any food.
Unit gets hot during use	The unit will become hot during use. Always use caution when operating the unit. Always use the front handle to open the unit, as this part of the handle is designed to stay cool to the touch while cooking.
The oil/grease is spilling on the countertop	Be sure to empty and clean the drip tray as often as needed and after each use.
Uncertain about which accessories are dishwasher safe	Reversible grill/griddle plates, waffle plates (sold separately), and drip tray are dishwasher safe.
Scratches on plates after constant daily use	While your plates are metal utensil safe, we recommend using plastic, silicone, or wooden utensils to prolong the life of your ceramic nonstick plates.
Unit has a slight odor and smokes a little	This is perfectly normal during first use and will disappear with use.
Power cord is in the way during storage	Store the power cord underneath the unit in the convenient wrap.

LIMITED WARRANTY

GreenPan Electrics are covered by a limited warranty against defects in materials and workmanship, beginning on the date you receive the product and lasting for two years. If your GreenPan Electrics product has a defect covered by the limited warranty during the warranty period, The Cookware Company (USA), LLC will, at its sole option, replace the product or provide a refund. Further information on the warranty claim process, exclusions from warranty coverage, and other terms can be found in the complete limited warranty for this product, available online at greenpan.us/warranty.

TERMS OF SALE; ARBITRATION

The terms on which The Cookware Company (USA), LLC sells GreenPan Electrics are available online at greenpan.us/pages/terms-of-sale (the "Terms"). The Terms contain very important information regarding your rights and obligations, as well as conditions, limitations, and exclusions that may apply to you. Please read them carefully.

In particular, the Terms provide that, by your purchase of this product, you and The Cookware Company (USA), LLC are agreeing to give up any rights to litigate in a court or before a jury, or to participate in a class action or representative action with respect to a claim. Other rights that you would have if you went to court may also be unavailable or limited in arbitration. Any claim, dispute, or controversy between you and The Cookware Company (USA), LLC arising from or relating in any way to your purchase of products or services will be resolved exclusively and finally by binding arbitration.

The arbitration will be administered by the American Arbitration Association ("AAA") in accordance with the Consumer Arbitration Rules (the "AAA Rules") then in effect, except as modified hereby. (The AAA Rules are available at adr.org or by calling the AAA at 1-800-778-7879.) The Federal Arbitration Act will govern the interpretation and enforcement of this arbitration and waiver provision.

The Cookware Company (USA), LLC will be responsible for the AAA filing fee of any such proceeding. Other than your right to pursue a claim in small claims court, as described in the Terms, the arbitrator will

have exclusive authority to resolve any dispute relating to arbitrability and/or enforceability of this arbitration provision, including any unconscionability challenge or any other challenge that the arbitration provision or these Terms are void, voidable or otherwise invalid. The arbitrator will be empowered to grant whatever relief would be available in court under law or in equity. Any award of the arbitrator(s) will be final and binding on each of the parties and may be entered as a judgment in any court of competent jurisdiction. Attorney fee shifting in this case is governed by the Terms. You agree to an arbitration on an individual basis. In any dispute, NEITHER YOU NOR THE COOKWARE COMPANY (USA), LLC WILL BE ENTITLED TO JOIN OR CONSOLIDATE CLAIMS BY OR AGAINST OTHER CUSTOMERS IN COURT OR IN ARBITRATION OR OTHERWISE PARTICIPATE IN ANY CLAIM AS A CLASS REPRESENTATIVE, CLASS MEMBER OR IN A PRIVATE ATTORNEY GENERAL CAPACITY. The arbitral tribunal may not consolidate more than one person's claims and may not otherwise preside over any form of a representative or class proceeding. The arbitral tribunal has no power to consider the enforceability of this class arbitration waiver and any challenge to the class arbitration waiver may only be raised in a court of competent jurisdiction.

If any provision of the arbitration agreement described herein and in the Terms is found unenforceable, the unenforceable provision will be severed and the remaining arbitration terms will be enforced.



1400031921