

# Kenmore

## I N S T R U C T I O N S

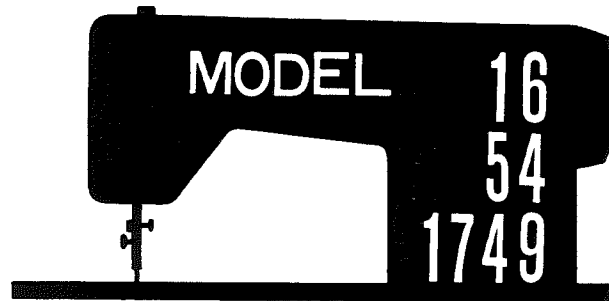

ZIG-ZAG SEWING MACHINE

P/N 59950

# TABLE OF CONTENTS

Adjusting for Good Stitches .....	14	Mending .....	22
Adjusting Pressure of Presser Foot .....	10	Narrow Hemming - 1/4" or Less .....	26
Adjusting Tensions .....	12-13	Needle and Thread Table .....	5
Applique .....	26	Needle Size .....	5
Basting .....	16	Overcasting .....	27
Buttonholes .....	24-25	Parts List .....	38-39
Buttons .....	23	Picking up Bobbin Thread .....	10
Changing Attachment Foot .....	11	Placement of Needle .....	5
Cleaning and Oiling .....	33-35	Removing Bobbin Case from Shuttle .....	6
Connecting Machine .....	4	Replacement of Belt .....	33
Decorative Stitching .....	18-21	Reverse Stitching .....	16
Double Needle .....	30-31	Setting Stitch Length .....	16
Dual Purpose Needle Plate .....	11	Setting Stitch Width .....	17
Fastening a Seam .....	16	Sewing Light .....	4
Feed Dog Control .....	10	Sewing on Lace .....	26
Gathering .....	27	Sewing on Plastic Films .....	32
Hems-Blind Stitch Hem .....	28-29	Straight or Three-Cornered Tear .....	23
Identification-Head Parts .....	2-3	Synthetics .....	32
Inserting Bobbin into Bobbin Case .....	8	Threading Upper Machine .....	9
Inserting and Removing Material .....	15	Turning a Corner .....	16
Inserting Pattern Disc .....	17	What To Do .....	36-37
Installing Machine Head .....	4	Winding the Bobbin .....	7
		Writing and Monogramming .....	27

FRONT VIEW

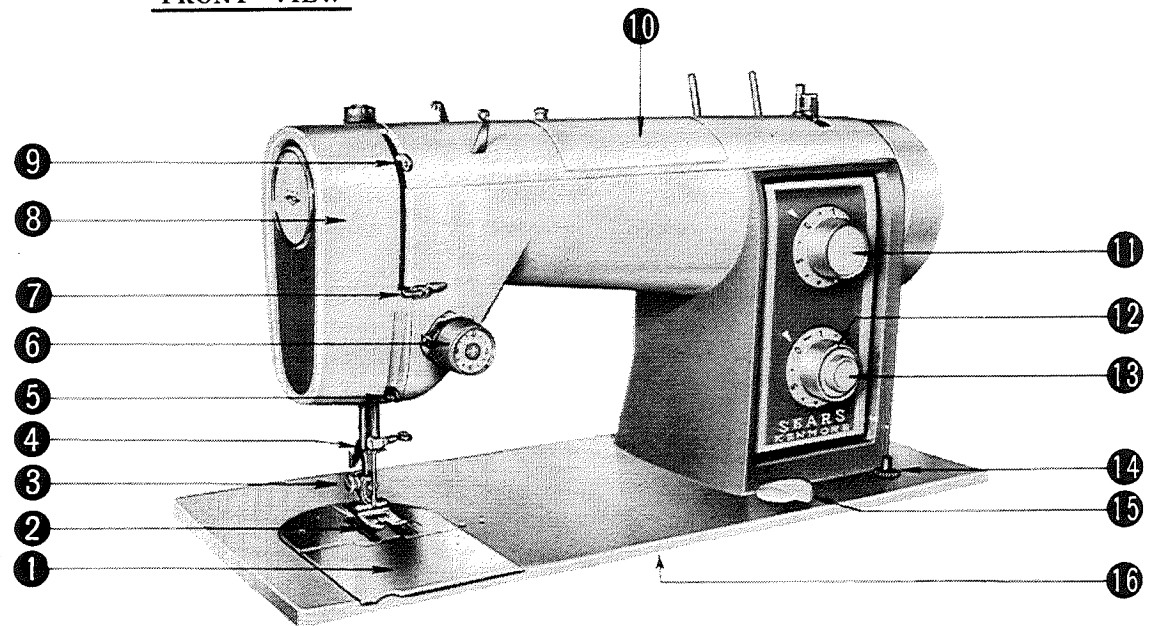

- |                            |                               |                                |
|----------------------------|-------------------------------|--------------------------------|
| 1. Hand Hole Cover Plate   | 7. Thread Guide               | 12. Stitch Length Control Knob |
| 2. Presser Foot            | 8. Face Cover Plate           | 13. Reverse Stitch Push Button |
| 3. Presser Foot Screw      | 9. Thread Take-up             | 14. Light Switch               |
| 4. Thread Guide            | 10. Pattern Disc Shaft Cover  | 15. Feed Dog Control Knob      |
| 5. Thread Guide            | 11. Stitch Width Control Knob | 16. Nomenclature Plate         |
| 6. Thread Tension Assembly |                               |                                |

BACK VIEW

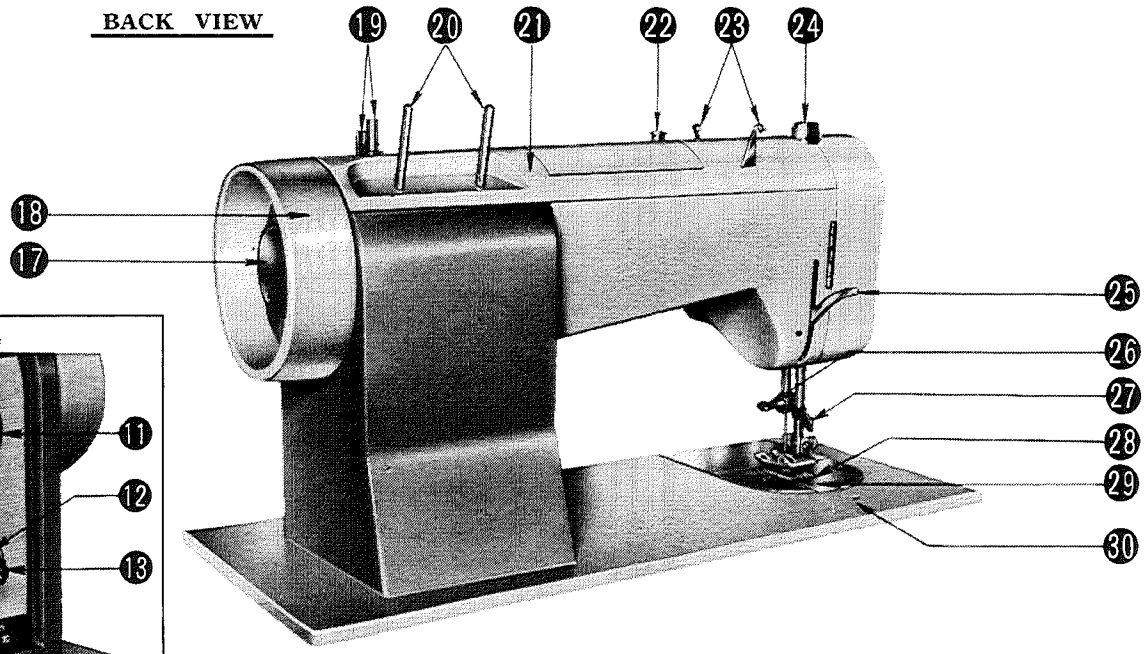

- |                             |                                |  |
|-----------------------------|--------------------------------|--|
| 17. Clutch Knob             | 22. Bobbin Winder Tension Disc | 27. Thread Cutter                            |
| 18. Hand Wheel              | 23. Upper Thread Guides        | 28. Feed Dog                                 |
| 19. Bobbin Winder Mechanism | 24. Presser Foot Knob          | 29. Needle Plate                             |
| 20. Thread Spool Pins       | 25. Presser Foot Lever         | 30. Guide Pin Hole for Buttonhole Attachment |
| 21. Arm Cover Plate         | 26. Needle Clamp Screw         |  |

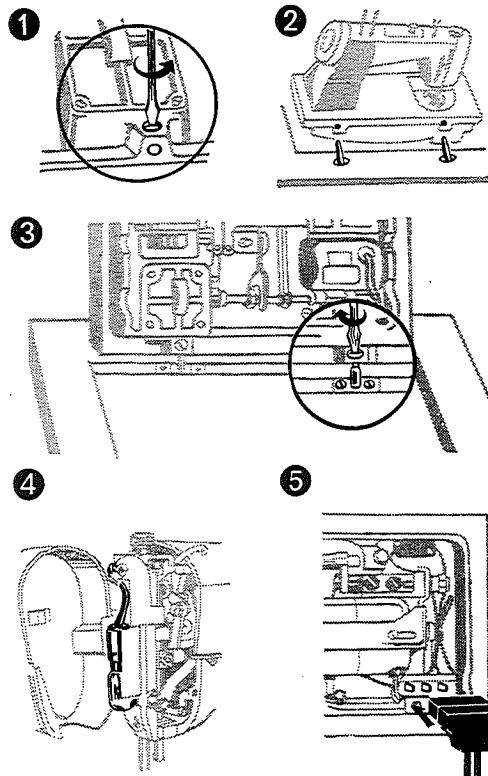

## INSTALLING MACHINE HEAD

Loosen the two hinge screws under holes in the rear edge of the machine bed (1). Raise hinge pins in the cabinet cutout (2). Slip machine head onto the pins and tighten hinge screws securely (3). Lower machine head to front flap.

Screw spool pins in place. Lay the plastic discs over the spool pins. Discs and pins are packed in the accessory box.

## SEWING LIGHT

The sewing light is located inside the face cover plate as shown. It may be turned on or off by pushing the light switch. In order to operate the machine the switch must be on.

To remove bulb, turn light switch off, open the face cover plate by swinging it open, push bulb in slightly, turn bulb clockwise, and remove from socket. To replace push in new bulb and turn counter clockwise. See illustration 4.

## CONNECTING MACHINE

Push the plug onto three-prong connector under the bed plate. Plug machine cord into any 110-120V wall outlet. See illustration 5.

## NEEDLE AND THREAD TABLE

THREAD SIZE	NEEDLE SIZE	FABRIC
Cotton 60 - 100 Synthetic Silk A	11	Sheer cottons, silks, and synthetics Fine laces
Cotton 60 - 80 Mercerized 50 Synthetic Silk A	14	Medium weight cottons Medium weight silks Medium weight synthetics Light weight woolens
Cotton 40 - 60 Mercerized 50 Mercerized heavy duty	16	Heavy weight cottons Medium to heavy weight woolens Heavy drapery fabrics
Cotton 30 - 50 Mercerized heavy duty	18	Heaviest cottons as for men's work clothes Heaviest woolen coating

### NEEDLE SIZE

Use **KENMORE 6021** needles. The size of needle should conform to the size of the thread and both should be suitable to the material. The same size thread should be used in the bobbin as on the upper part of the machine for ordinary sewing.

Never use a bent needle or one with a blunt point.



This is the exact length of the needle to be used in your machine. Comparison with this illustration will determine whether the needle you have is the correct one for your machine.

### PLACEMENT OF NEEDLE

Raise needle bar to its highest position by turning hand wheel toward you. Loosen needle clamp screw.

Hold the needle with flat side away from you. Slip the needle as far as it will go into the needle clamp, and tighten the needle clamp screw.

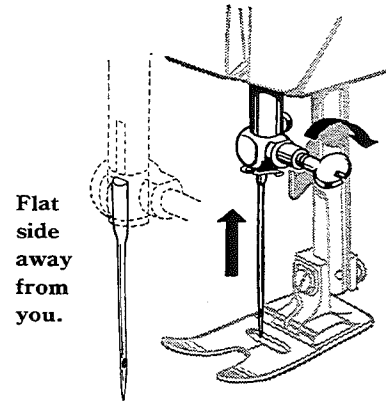

Needle at its highest position.

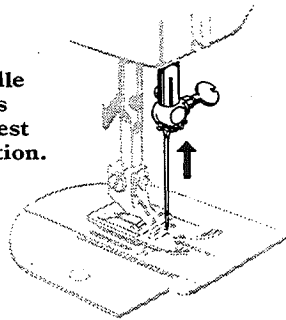

Pull out latch.

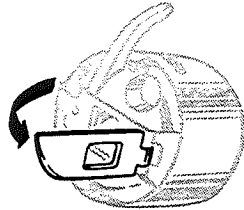

Pull bobbin case straight out.

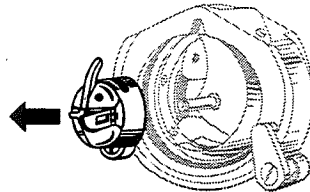

## REMOVING BOBBIN CASE FROM SHUTTLE

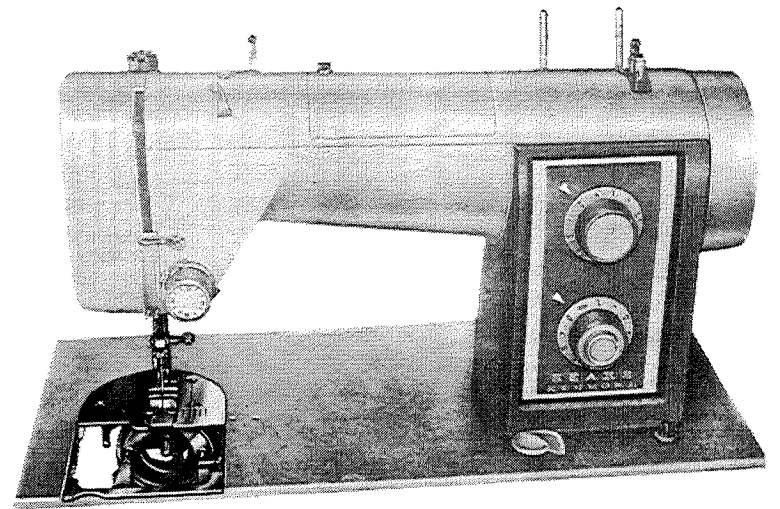

# WINDING THE BOBBIN

①

Place thread on left spool post. Draw thread as shown.

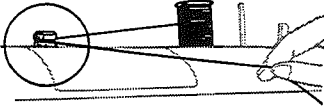

④

Release clutch by turning clutch knob toward you. Start machine.

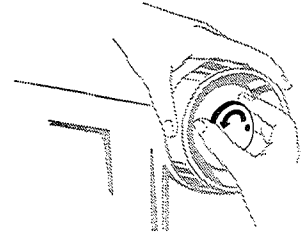

②

Wind thread around bobbin a few times.

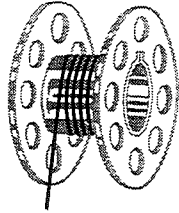

⑤

When bobbin is full, winding mechanism stops.

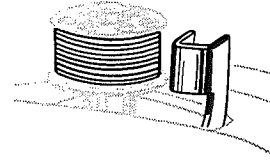

③

Place bobbin onto bobbin winder shaft. Push bobbin winder latch until it clicks.

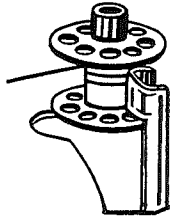

⑥

Tighten clutch knob and remove bobbin.

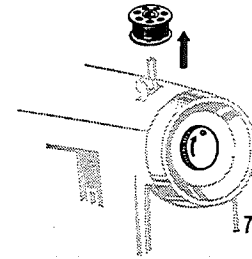

## INSERTING BOBBIN INTO BOBBIN CASE.....CASE INTO SHUTTLE

- 1 Guide bobbin onto center pin of bobbin case.
- 2 Pull thread through slot.
- 3 Pull thread under tension spring.
- 4 Holding latch, position case into shuttle, release latch.

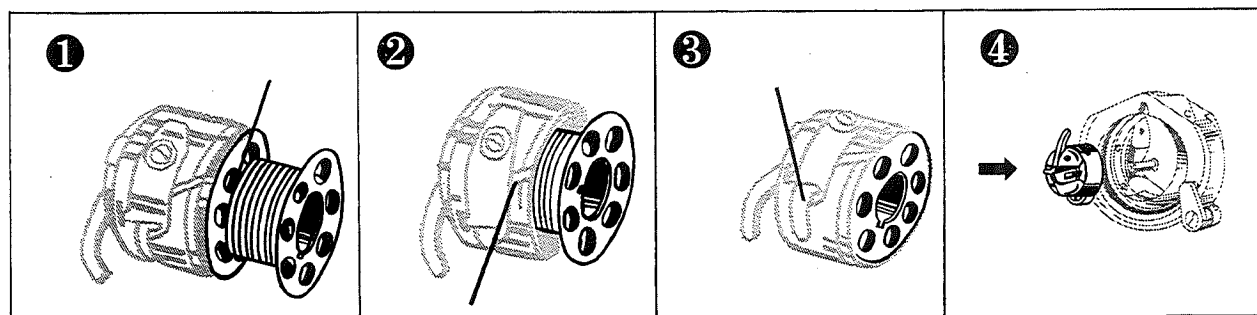

# THREADING UPPER MACHINE

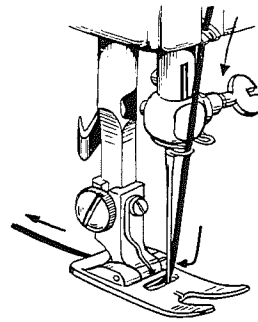
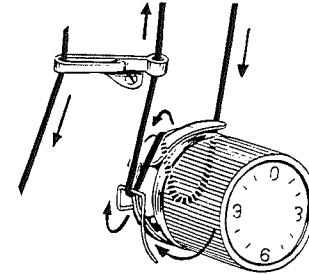
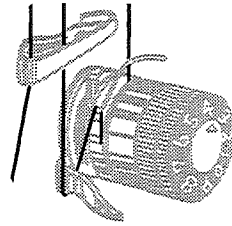
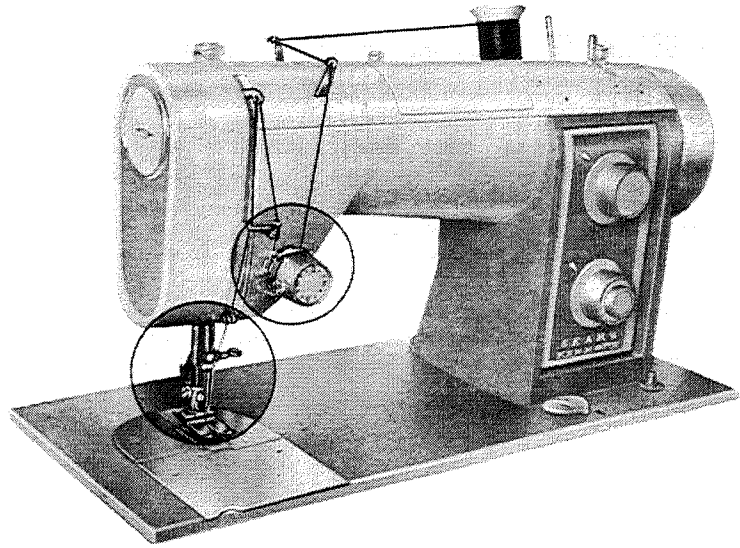

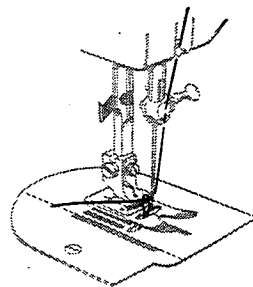

### PICKING UP BOBBIN THREAD

Raise presser foot lever. Hold needle thread loosely in left hand and rotate hand wheel toward you one complete turn. Bring bobbin thread up by pulling upper thread (See illustration). Place threads back under presser foot.

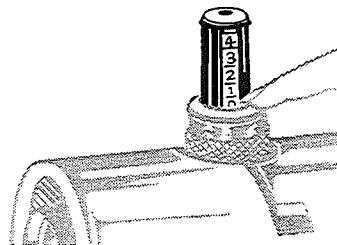

### ADJUSTING THE PRESSURE OF THE PRESSER FOOT

Push down outer ring of presser foot knob (See illustration). This will release pressure of presser foot. To increase pressure, push down inner pin until suitable pressure is obtained.

For ordinary sewing, the inner pin should be about half way down. When sewing multiple thickness or heavy material, reduce the pressure. Increase it when sewing sheer fabrics.

Insufficient pressure may cause skipped stitches or difficulty in guiding the fabric. If feed dog or presser foot marks appear on the fabric, reduce the pressure.

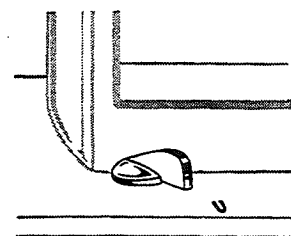

### FEED DOG CONTROL

The feed dog control knob is situated on the right front of machine bedplate. When knob is turned to the left, feed dog drops and does not pull material. This allows the operator freedom of movement of material, as for darning. For regular sewing, turn knob to the right, "U" (Feed dog up).

## DUAL PURPOSE NEEDLE PLATE

The dual purpose needle plate provides a small round needle hole (A) for straight stitching and a wide oval hole (B) for zigzag and decorative stitching on the center plate (C).

To slide center plate for model 16 and 54, remove hand hole cover plate and move lever (D) to left for straight stitching and right for zigzag stitching until it clicks.

To reverse center plate for model 1749, remove hand hole cover plate, depress slightly and move lever (D) to the right; this releases center plate so it can be removed. Reverse and reposition center plate, locking it into place by moving lever (D) to the left.

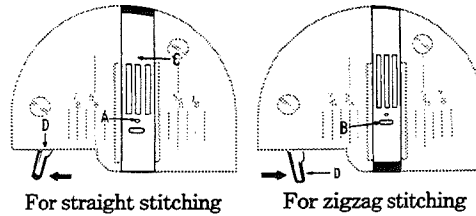

## CHANGING THE ATTACHMENT FOOT

Be sure needle is in the up position. Raise presser foot lever.

### Snap-on presser feet

1. Push the release button on back of clamping shank and the foot will be released (Fig. 1).
2. Place the desired foot on the needle plate aligning the needle holes and lower the presser bar by dropping the presser foot lever. The clamping shank will snap on the foot.

Note: The presser foot knob should be down for maximum pressure when attaching foot.

### One-piece presser feet

1. Loosen presser foot thumb screw and remove the clamping shank or presser foot.
2. Insert the desired foot from the front. Lower the presser foot lever and tighten the screw using the large screw driver to make certain the foot is secure.

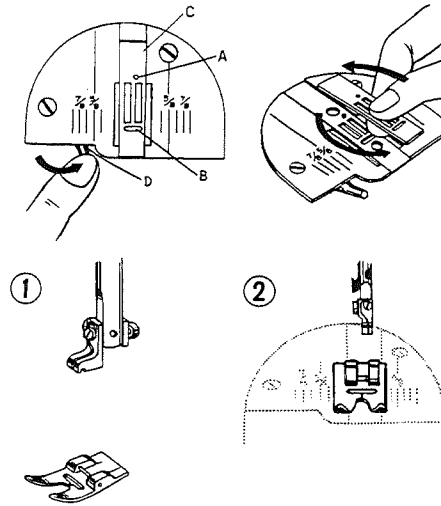



## ADJUSTING TENSIONS

1

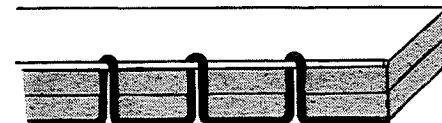
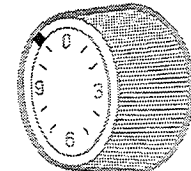
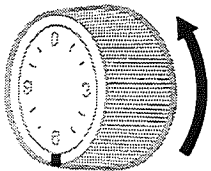

Fig. 1

A perfect stitch will have threads locked between the two layers of fabric with no loops on top or bottom. (Refer to page 14)

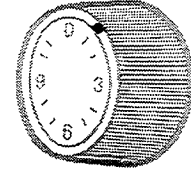
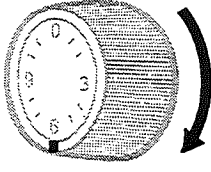
PROBLEM	REMEDY
<p>2 Upper thread too tight</p>  <p>Fig. 2</p> 	<p>Decrease Tension</p> 
<p>3 Upper thread too loose</p>  <p>Fig. 3</p> 	<p>Increase Tension</p> 

When stitching is unsatisfactory as in figures 2 and 3, adjust the upper thread tension. Lower thread tension requires adjustment less frequently than the upper thread tension.

When stitch is satisfactory, as in figure 1 and seam is badly puckered, the cause may be tight tensions and both upper and lower may be adjusted. (See page 14)

When adjusting the tension on the bobbin case, make slight adjustments with a screwdriver. (See page 14)

It is necessary to reduce the upper thread tension somewhat when doing decorative stitching. The wider the stitch the less tension is needed. (See page 18)

### INCREASE TENSION

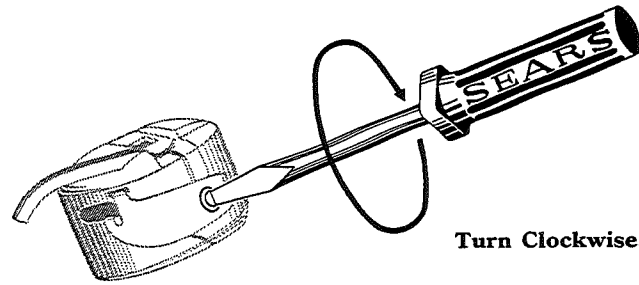

Turn Clockwise.

### DECREASE TENSION

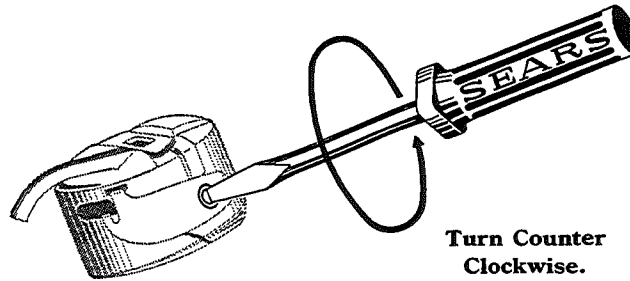

Turn Counter  
Clockwise.

## ADJUSTING YOUR SEWING MACHINE FOR GOOD STITCHES

When your sewing machine does not sew a properly locked stitch, check the following:

1. Insert a new needle of the correct size for the thread and fabric you are using. Consult chart on page 5 for needle size.
2. The upper and bobbin thread should be matched in size and type.
3. Check threading carefully. See page 9.
4. Check the thread tension balance. Use mercerized thread, and a correct size needle for the fabric you are using. Do not try test with synthetic thread as it will not break.

Begin with a full bobbin, properly threaded into the case. Set the stitch length at about 12 stitches per inch. Fold a 6" square of your fabric in half diagonally, forming a triangle. Make a line of stitching  $\frac{1}{2}$ " from fold.

- a. If seam is puckered-both tensions are too tight.
- b. If the bottom thread lays on the fabric-tighten upper thread tension, and repeat test. See page 12, Figure 3.
- c. If the top thread lays on the fabric-loosen upper thread tension, and repeat test. See page 12, Figure 2.

Grasp the stitching and pull with a snap to make threads break.

- a. If both threads break-tensions are balanced.
- b. If neither thread breaks-both tensions are too loose.
- c. If upper thread breaks-loosen upper tension.
- d. If lower thread breaks-tighten upper tension.

Both threads do not have to break at the same place, but they should break on the same snap.

Bobbin tension may be reset by the following procedure. Start with a loose bobbin thread tension. Tighten the spring screw gradually until bobbin case and full bobbin can be gently lifted from your hand by the end of the bobbin thread.

## INSERTING AND REMOVING THE MATERIAL

---

For all kinds of sewing, consult chart page 5.

Before placing the material on the machine see that:

- \* The presser foot and needle clamp screws are both tight.
- \* The sizes of the needle and thread suit the kind of work to be done.
- \* The needle and take-up lever are at their highest position.
- \* The tensions have been properly adjusted.
- \* The ends of threads have been drawn about 4 inches to the rear of the machine.
- \* The feed dogs are up.
- \* Stitch length and width controls are set at desired settings.

Experiment by sewing on the fabric to be used to determine tension adjustments and correct stitch settings.

Place material under the presser foot, insert the needle into the material by turning the hand wheel toward you, lower presser foot and start sewing. To facilitate placement of heavy fabrics under the presser foot, the presser foot lever can be raised beyond the normal "up" position.

To remove the work, first turn the hand wheel toward you until the needle is at its highest position, then raise the presser foot, draw material to the rear and cut off excess thread with the thread cutter located on the presser bar.

**IMPORTANT:** Always turn the hand wheel toward you! When the machine is not being used, place a piece of material over the feed dog and lower the presser foot. Always have fabric under the presser foot when operating the machine. Operating threaded machine without fabric will cause it to jam by forcing thread into the shuttle. See pages 34 & 35.

### SETTING STITCH LENGTH

Turn stitch length control knob to the desired point between 0 and 5. The red mark indicates the setting for a satin stitch. This will vary slightly depending upon the type of material to be sewn. The 5 setting is the longest stitch. The size of the stitch selected will depend on the fabric sewn.

### REVERSE STITCHING

Push button when reverse stitching is required. Reverse stitching, often called back tacking is used for reinforcing and finishing all seams.

### TURNING A CORNER

Stop sewing machine with needle in fabric. Raise presser foot. Turn fabric. Lower presser foot and continue stitching.

### BASTING

For accomplishing quicker, more even and firmer basting, we suggest you regulate the machine in the following manner; Set stitch length at No. 5 for the longest possible stitch. Basting is easily removed by pulling bottom thread. When basting very sheer fabrics, use a paper backing.

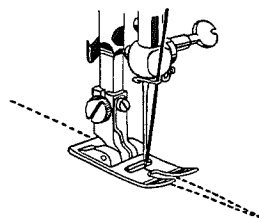
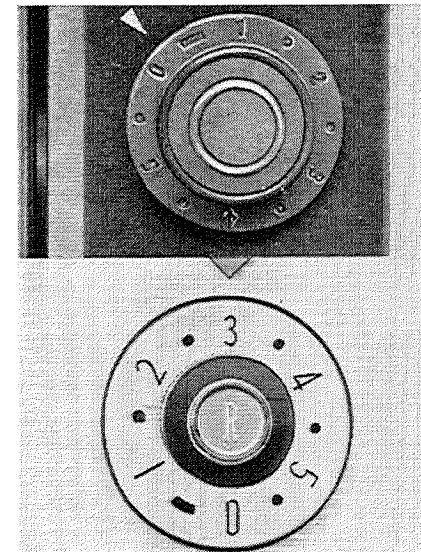

### FASTENING A SEAM

Be sure both threads are drawn back under the presser foot. Lower needle into fabric about  $\frac{1}{2}$  inch from beginning of seam. Push button and stitch in reverse until needle reaches beginning of seam. Release button and complete seam. When you reach the end, push button and sew back over  $\frac{1}{2}$  inch of completed seam.

## ZIGZAG CONTROL

### SETTING STITCH WIDTH

Insert disc No. 1A. Turn the stitch width control knob to the desired setting between 0 and 5 on the knob. Zigzag stitch width increases from 0 to 5. Straight stitching is possible with control on 0 setting or by removal of pattern disc. Be sure the dual purpose needle plate is set properly. (See page 11).

When sewing with the double needle the stitch width control must not be advanced beyond 3½ setting.

### INSERTING PATTERN DISC

1. Turn handwheel so that the needle is in its highest position.
2. Pull pattern disc shaft cover open.
3. Push cam follower release lever **A** to the right and keep it there during insertion. See illustration 1.
4. Grasp pattern disc and slip disc onto the shaft. Make sure the retaining pin **B** enters hole in disc.
5. To begin a pattern at a specific point each time, push the cam follower release lever to the right with one hand, depress the retaining pin. Turn the cam so that the white dot engraved on the disc is aligned with the point on the cam follower **C**. See illustration 2. Shut cover.
6. To remove pattern disc, open cover and pull disc from the shaft.

There are two different patterns on each disc. A picture of each pattern is on the disc surface. Position disc into machine with desired pattern facing up.

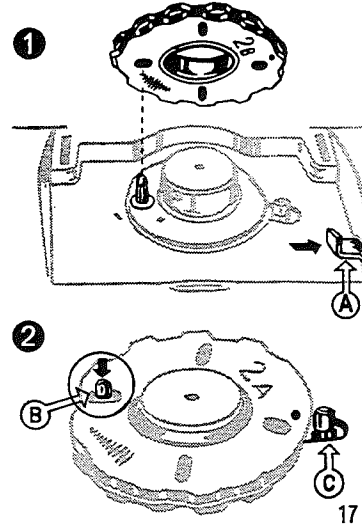

## DECORATIVE STITCHING

This machine enables you to sew beautiful decorative and embroidery stitches by means of various discs supplied with your machine. The movements of the needle are controlled by the disc. Basic decorative stitches are made with stitch width at 5 and stitch length at the red marking on the dial. The latter will vary slightly depending upon the type of material to be sewn. All patterns also can be made with double needle. See page 31. Pattern will be changed if using any other length or width. Decorative stitch No. 1A is generally referred to as the satin stitch.

It is necessary to reduce the top tension somewhat for decorative stitching. As the stitch width is increased, the tension should be decreased. This will prevent the material from puckering and will prevent the bobbin thread from coming up on the top of the fabric.

## REMEMBER THE FOLLOWING REFERENCES

1. Pattern disc, pattern and number engraved on it..... 17
2. Stitch length control knob ..... 16
3. Stitch width control knob..... 17
4. Double needle ..... 30 - 31



1A



1B



2A



2B



3A



3B



4A



4B



5A



1B



9B



9A



8B



8A



7B



7A

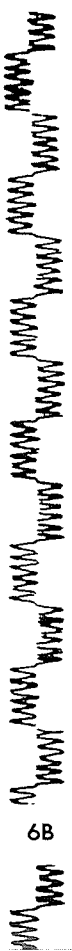

6B



6A



5B



10A



10B



11A



11B



12A



12B



13A



13B

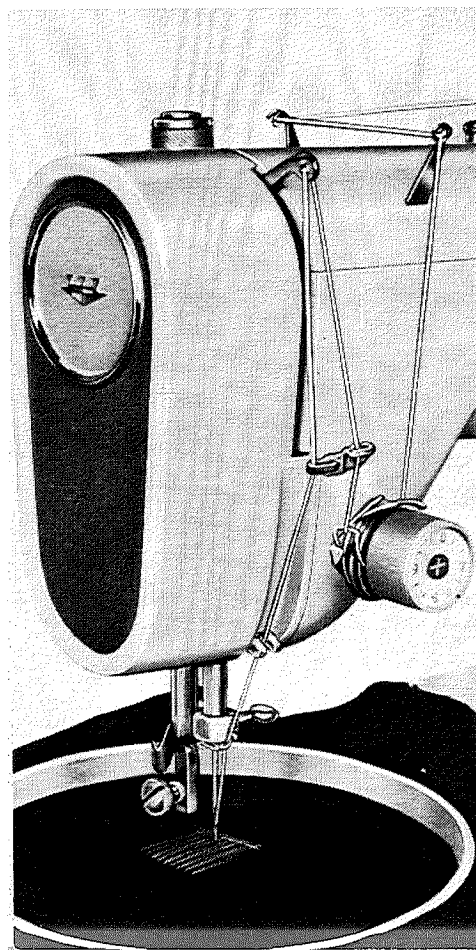

## MENDING

### DARNING

Stitch width	0
Feed dog control	Left

Remove presser foot. Stretch fabric between embroidery hoops and place under needle. Draw the bobbin thread up through fabric by holding the upper thread and taking one stitch at the spot where you wish to begin darning. Lower presser bar. Start sewing at a medium machine speed. Move the fabric back and forth with a steady rhythm to cover the darning area. Then turn the fabric and sew another layer of stitching at right angles to the first. Move the fabric fast for long stitches, slowly for short stitches.

If you wish to darn without using embroidery hoop, leave the presser foot attached, move feed dog control to the left, and push down outer ring of presser foot knob, thereby the pressure on the presser foot is released. Then proceed as above, stretching fabric tightly between hands.

## BUTTONS

Use disc #1A

Align two holes of button with slot of presser foot and lower foot to hold button securely. Drop feed dog. Turn hand wheel by hand until needle point is just above button. Adjust stitch width so that needle will align with a hole of button. Turn hand wheel again by hand so that needle goes into second hole, readjust stitch width if necessary. Stitch a number of times, turning hand wheel manually. Finish with an extra 2 inches of thread, draw thread to reverse side and tie securely.

If using a 4 hole button repeat the above procedure.

**NOTE:** To make a small thread shank when sewing on a flat button, place a straight pin or needle between the holes of the button.

## STRAIGHT OR THREE-CORNERED TEAR

Stitch width 3 - 4

Stitch length at red mark

Pattern disc # 4A (Model 16, 1749, 542)

# 1A (Model 540, 541)

Position tear under needle and stitch along the straight tear catching sides of material. When mending a three cornered tear, stitch from each end to center.

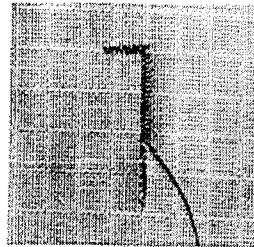
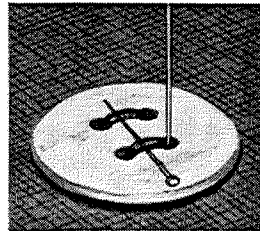
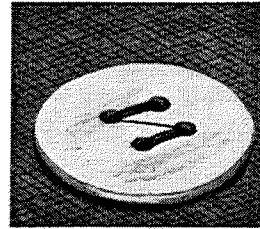

## BUTTONHOLES

Use disc # 1A  
Stitch width knob-Red zone

Feed dog control - Left  
Cover plate for buttonholes

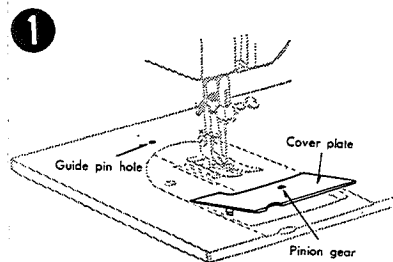

Remove regular cover plate and insert buttonhole cover plate.

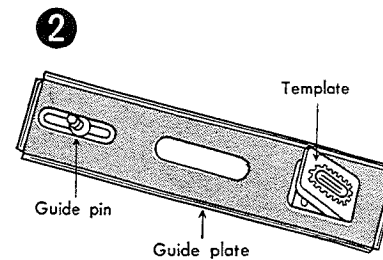

Select desired template and snap into guide plate.

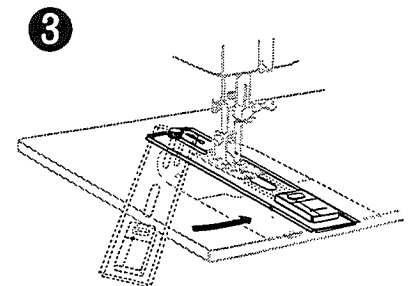

Pull guide plate all the way forward so that guide pin is at S. This will enable you to start at one end of the buttonhole. Screw guide pin on guide plate into guide pin hole on machine bed.

Drop guide plate into place with template fitting over the pinion gear.

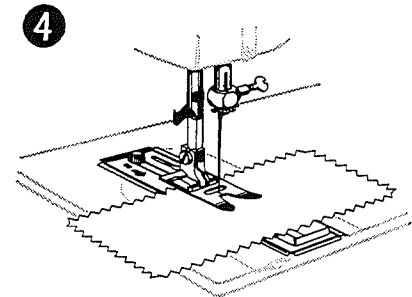

**4**

Pick up bobbin thread through guide plate and draw threads toward back. Place material on the guide plate. Drop presser foot and start sewing. Buttonhole will be formed. The buttonhole size and shape is not influenced by the stitch length knob so it may be set on any position.

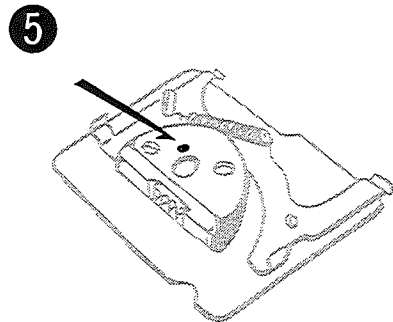

**5**

An occasional drop of oil on the oiling hole provided on the back of the buttonhole cover plate will provide smooth operation of your buttonhole maker.

## HINTS FOR PERFECT BUTTONHOLES

Mark the position of each buttonhole on the garment with chalk or a line of basting.

Loosely woven fabrics and fabrics that stretch easily such as jersey should have an interfacing of a firm fabric. Use cambric or taffeta between woolens and rayons-organdy or lawn between light weight and sheer fabrics.

Use buttonhole scissors or buttonhole cutter to cut buttonhole open.

Always make a practice buttonhole on a piece of the fabric to be used in the garment.

A wider stitch width may be desirable on heavy weight fabrics.

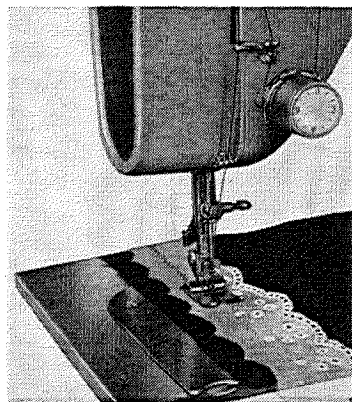
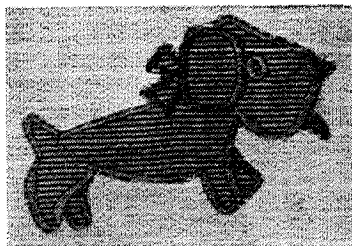

## APPLIQUE Use disc #1A

Baste cutout applique to fabric. Set stitch width 2 to 4. Set stitch length at the red marking. Zigzag stitch around applique completely covering the raw edge.

## SEWING ON LACE Use disc #1A

Set stitch width to 2. Set stitch length to 2 or 3. Place fabric under the presser foot and position lace  $\frac{1}{4}$  inch from edge of fabric. Position fabric and lace so that right stitch catches left edge of lace. Continue stitching so that edge of lace is overcast.

## NARROW HEMMING - $\frac{1}{4}$ " OR LESS

Presser Foot - Zigzag  
Needle Plate Hole - Zigzag slot  
Stitch Width - 5  
Stitch Length - 2 to 4

Remove zigzag disc from machine. Place fabric with bulk of garment to left of foot and the edge of hem directly beneath needle. Straight Stitch. Use transparent plastic foot, if available, for improved visibility.

## OVERCASTING

Use disc #1A

Both length and width settings may be varied depending on fabric used. Zigzag stitch around raw edge of fabric to completely cover the edge.

## GATHERING

Attach gathering foot. (See page 11). Set machine for straight stitching and test gathers on a scrap of the same fabric you plan to use. Fullness will depend largely on thread tension and length of stitch. For slight fullness, tighten thread tension and set stitch length for ordinary sewing. For greater fullness, lengthen stitch and keep tight thread tension. Fullness will vary with different fabrics.

## WRITING AND MONOGRAMMING

Use disc #1A

Free hand  
Stitch width      0 to 5  
Feed dog control   Left

Draw initials or words to be sewn on fabric and fit fabric into embroidery hoops. Writing is done with either zigzag or straight stitching. Remove presser foot. Set stitch width for straight or zigzag stitches as desired. Slip hoop and fabric under the needle, lower presser bar and take one stitch to raise bobbin thread through fabric. Using a medium speed, stitch along marked outline, guiding fabric carefully by hands.

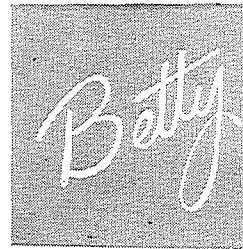
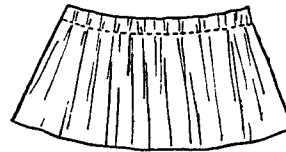
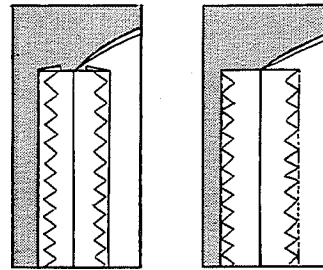

# HEMS

## BLIND STITCH HEM

Disc #18  
Stitch width 2-3  
Stitch length 2-4

1

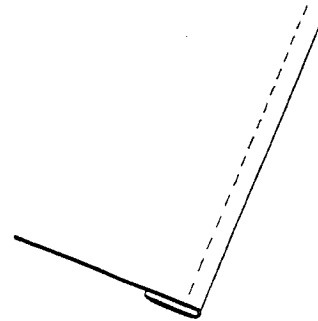

1. Prepare the hem with a turned and edgestitched finish, or

2

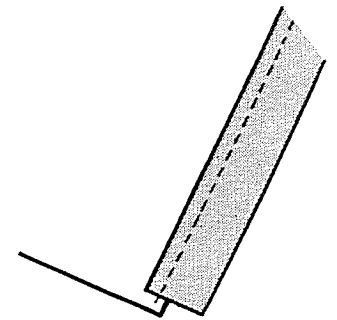

2. Apply seam tape along the raw edge with either straight or zigzag stitching.

3

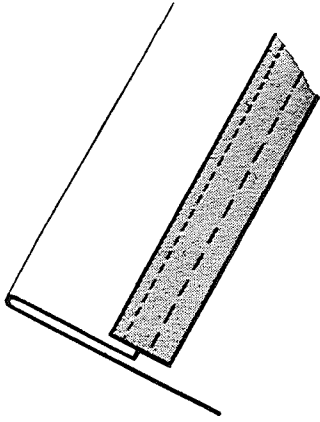

3. Turn hem and baste  $\frac{1}{8}$  inch from the edge of the seam tape using longest stitch on sewing machine.

4

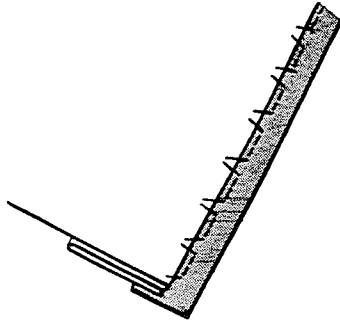

4. Fold garment back along basting line and stitch along garment fold using disc #1B.

5

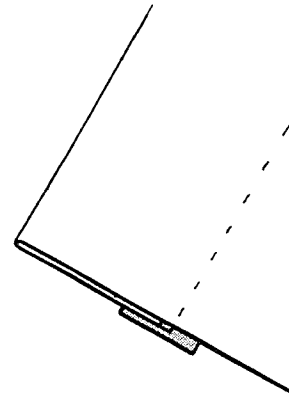

5. Remove basting and press hem. The basting step may be eliminated in a straight hem.

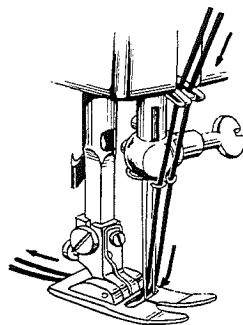
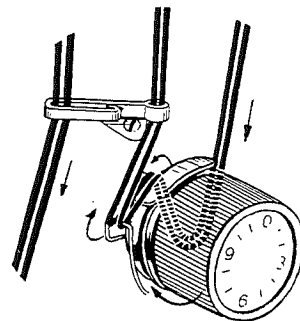

## DOUBLE NEEDLE

### SETTING THE DOUBLE NEEDLE

Raise the needle bar to its highest position and loosen needle clamp screw. Hold double needle assembly with flat side away from you. Slip the needle as far as it will go into needle clamp, and tighten the screw.

### THREADING THE DOUBLE NEEDLE

Place a spool of thread on each spool pin. Draw both threads through upper thread guides. Pass a thread between each set of tension discs of the thread tension assembly. Continue threading as you would for single needle sewing except where double thread guides are provided. Draw one thread through each side of the double thread guides and through each needle from front to back. Pull several inches of thread through. (See illustrations). Thread bobbin and pick up bobbin thread as for single needle sewing.

### THREAD SELECTION

Use only mercerized sewing thread size 50 or finer. The same size thread is recommended for both upper and lower threading.

# DOUBLE NEEDLE

## STITCHING

All decorative patterns are possible with double needle. Before starting any stitching operation, check needle drop by turning the handwheel manually. Needle should enter fabric without touching the presser foot or needle plate. The stitch width control must not be advanced beyond 3½ setting.

## TURNING A CORNER

To turn a square corner when stitching with a double needle, stop stitching with the longer needle tip just piercing the fabric. Raise the presser foot, shift fabric half the turn, lower presser foot and take one stitch. Raise the presser foot again, complete the turn, and begin stitching in the new direction.

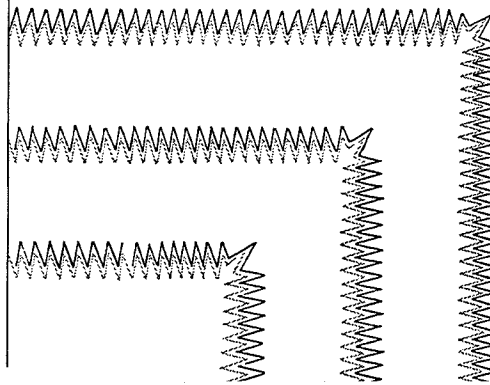
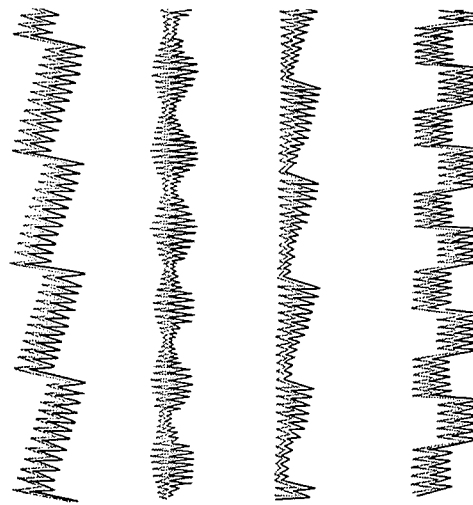

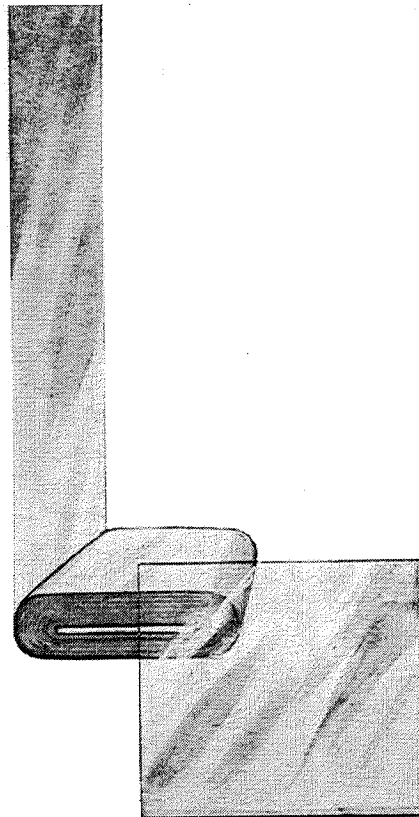

## SYNTHETICS

Your KENMORE will sew all the new fabrics of synthetic fiber, such as nylon, \*Orlon, \*\*Dacron, rayon, acetate, blends of these, and combinations of synthetic and natural fibers. When stitching a fabric of blended or combined fibers, handle it as you would a material of the fiber present in the largest percentage. For example, a fabric woven of 60% Orlon and 40% silk should be handled as one made entirely of Orlon.

When stitching a fabric that is over 50% synthetic fiber, remember:

- a. Select patterns of the loose fitting type with cap or kimono sleeves, because most synthetic fiber fabrics cannot be eased with steam pressing, and are not absorbent.
- b. Use a synthetic thread.
- c. Use a fine needle as recommended in chart on page 5.
- d. Wind the bobbin in the usual way, but do not pass thread between tension discs. Guide thread by hand for a smoothly wound bobbin.
- e. Choose the stitch length that gives the most satisfactory seam.
- f. Check thread tensions by sewing on a double thickness of the fabric to be used. Usually the upper thread tension must be loosened. Sometimes both bobbin and upper thread tensions must be loosened (Pages 12, 13).

## SEWING ON PLASTIC FILMS

Set the machine with normal thread tensions and a large size stitch. Use a fine needle and mercerized thread. Hold plastic pieces together with cellophane tape or paper clips rather than pins. Sew corners slightly rounded rather than square.

\*Trademark for Dupont's Acrylic fiber. \*\*Trademark for Dupont's polyester fiber.

## REPLACEMENT OF THE BELT

Loosen motor bracket screw, push motor toward handwheel to loosen belt. Remove belt from motor pulley. Remove clutch knob screw, unscrew clutch knob and remove clutch washer. Note position of clutch washer-it must be reassembled in the same position. Slide hand wheel out sufficiently so belt can be pulled out over hand wheel. Install new belt and reverse the above procedure for reassembling.

To provide proper belt tension, pull motor away from bedplate to take out slack from belt using finger pressure and tighten motor bracket screw securely.

## CLEANING AND OILING

Keep the moving parts free from dust and thread for quiet and efficient operation. Cleaning should be done with a small brush.

When machine runs hard or makes excessive noise, place a drop of KENMORE sewing machine oil at the points indicated in figs. A, B, & C.

Swing hinged face cover plate open to oil points indicated at end of machine head.

Fig. A

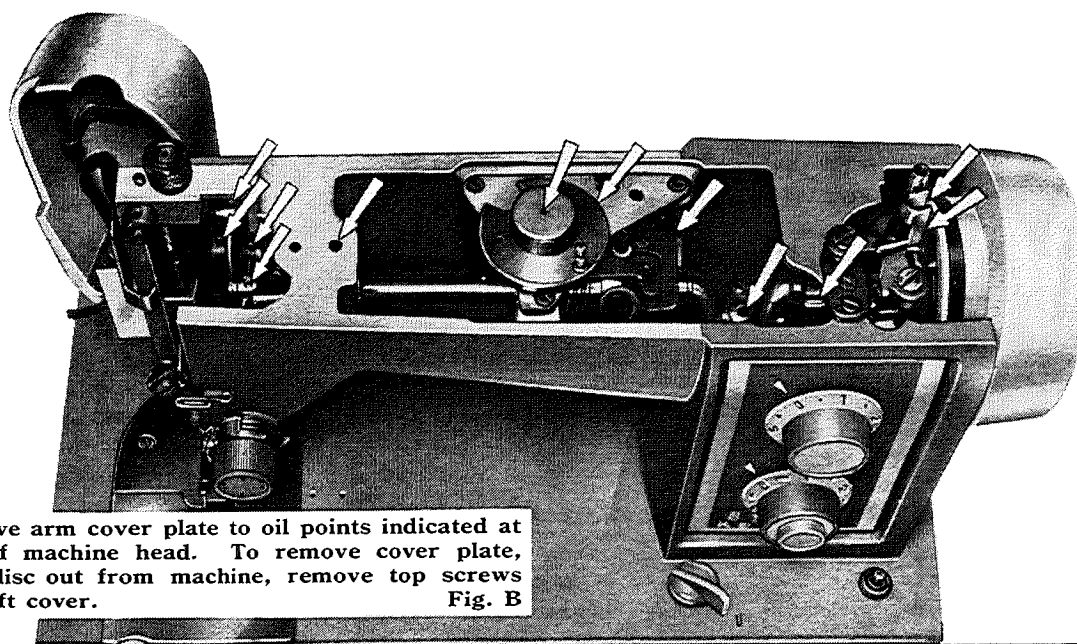

Remove arm cover plate to oil points indicated at top of machine head. To remove cover plate, take disc out from machine, remove top screws and lift cover. Fig. B

It may be necessary to clean the shuttle area occasionally.

1. Raise the needle bar to its highest point and remove bobbin case.
2. Push levers sideways from the shuttle assembly and lift shuttle race cover and shuttle out by the center pin.
3. Clean the shuttle race of any lint or small particles of thread with a small brush.
4. Put a drop of oil on the center pin of the shuttle and on shuttle race (see arrows).

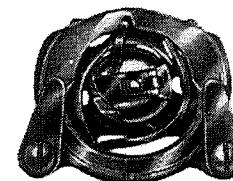

Shuttle Assembly

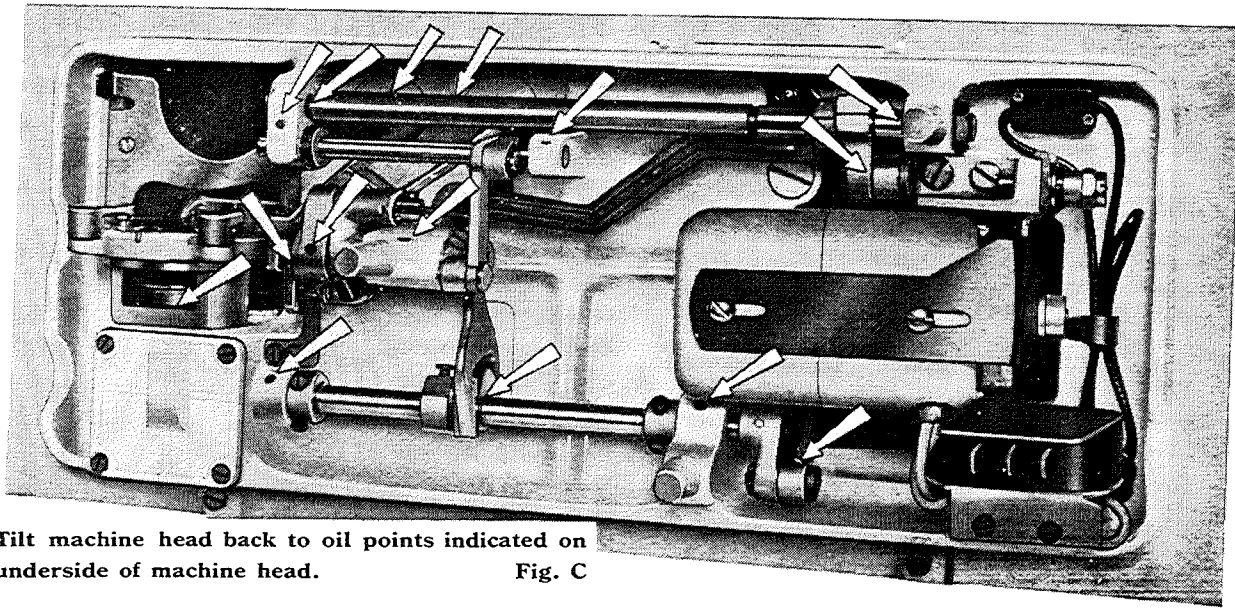

Tilt machine head back to oil points indicated on underside of machine head. Fig. C

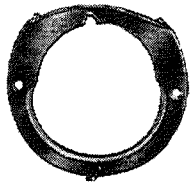

Shuttle Race Cover

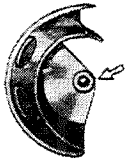

Shuttle

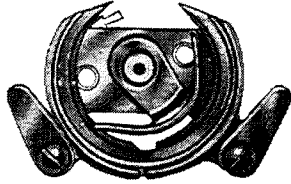

Shuttle Race

To reassemble, hold shuttle by center pin and fit carefully into assembly opposite the shuttle driver. Slip shuttle race cover into place. Snap the levers into position. Occasionally, remove the needle plate and clean feed dog with a soft brush.

## WHAT TO DO

PROBLEM	PROBABLE CAUSE	CORRECTION
Irregular Stitches	Incorrect size needle. Improper threading. Loose upper thread tension. Pulling fabric. Light pressure on presser foot. Loose presser foot. Unevenly wound bobbin.	Choose correct size needle for thread and fabric (page 5). Rethread machine (page 9). Tighten upper thread tension (page 12). Do not pull fabric; guide it gently. Increase pressure on presser foot (page 10). Reset presser foot (page 11). Rewind bobbin (page 7).
Breaking Needles	Pulling fabric. Incorrect size needle. Incorrect setting of needle. Loose presser foot.	Do not pull fabric; guide it gently. Choose correct size needle for thread and fabric (page 5). Reset needle (page 5). Reset presser foot (page 11).
Bunching of Thread	Upper and lower threads not drawn back under presser foot. Feed dog down.	Draw both threads back under presser foot (page 10). Raise feed dog (page 10).
Puckering	Incorrect thread tension(s). Light pressure on presser foot. Using two different sizes or kinds of thread. Bent or blunt needle. Loose presser foot. Fabric too sheer or too soft.	Reset thread tension s) (pages 12, 13). Increase pressure on presser foot (page 10). Upper thread and bobbin thread should be same size and kind. Insert new needle (page 5). Reset presser foot (page 11). Use underlay of tissue paper or tarleton when stitching.

# WHAT TO DO

PROBLEM	PROBABLE CAUSE	CORRECTION
Skipping Stitches	<p>Incorrect size needle.</p> <p>Bent or blunt needle.</p> <p>Incorrect setting of needle.</p> <p>Tight upper thread tension.</p> <p>Light pressure on presser foot.</p>	<p>Choose correct size needle for thread and fabric (page 5).</p> <p>Insert new needle (page 5).</p> <p>Reset needle (page 5).</p> <p>Loosen upper thread tension (page 12).</p> <p>Increase pressure on presser foot (page 10).</p>
Breaking Upper Thread	<p>Starting to stitch too fast.</p> <p>Improper threading.</p> <p>Tight upper thread tension.</p> <p>Incorrect size needle.</p> <p>Sharp eye in needle.</p>	<p>Start to stitch at a medium speed.</p> <p>Rethread machine (page 9).</p> <p>Loosen upper thread tension (page 12).</p> <p>Choose correct size needle for thread and fabric (page 5).</p> <p>Insert new needle (page 5).</p>
Breaking Bobbin Thread	<p>Improper bobbin case threading.</p> <p>Tight bobbin thread tension.</p> <p>Lint in bobbin case or shuttle.</p>	<p>Check bobbin case threading (page 8).</p> <p>Loosen bobbin thread tension (page 13).</p> <p>Clean bobbin case and shuttle (pages 34, 35).</p>
Fabric not Moving	<p>Feed dog down.</p> <p>Light pressure on presser foot.</p> <p>Threads knotted under fabric.</p>	<p>Raise feed dog (page 10).</p> <p>Increase pressure on presser foot (page 10).</p> <p>Place both threads back under presser foot before beginning to stitch.</p>
Machine Jamming (Knocking Noise)	<p>Thread caught in shuttle.</p>	<p>Disassemble and clean shuttle (pages 34, 35).</p>

## PARTS LIST

All parts listed here may be ordered through your nearest Sears or Simpsons-Sears retail store, catalog sales office or mail order house.

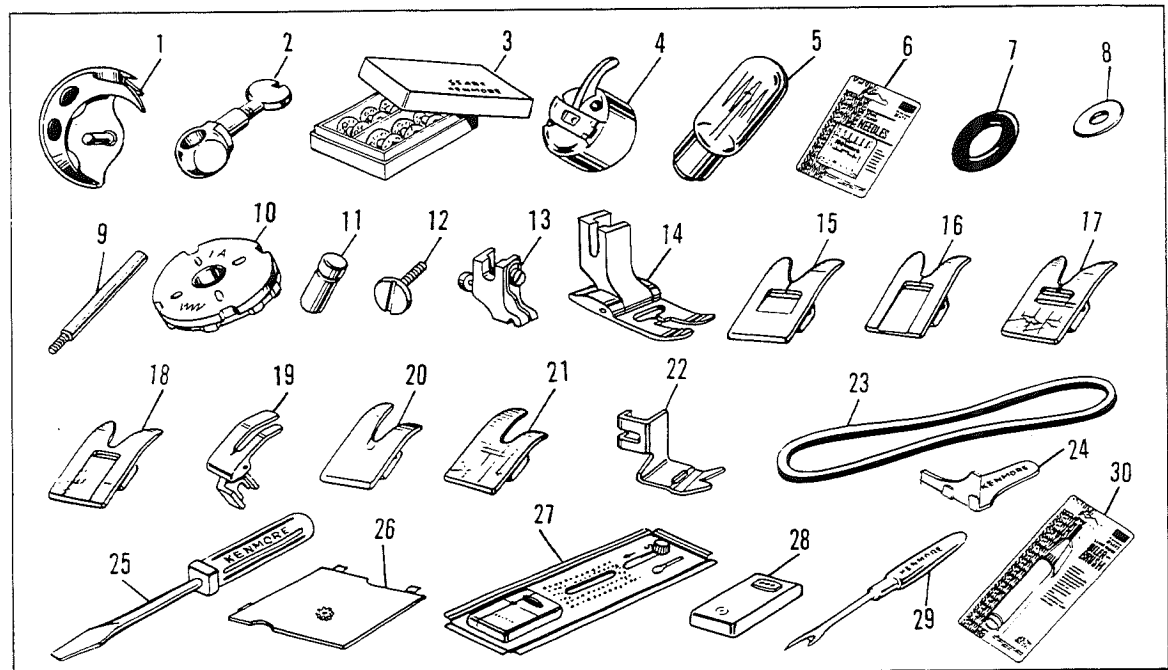

When ordering these parts, please be sure to mention the following references :

1. Model & serial numbers of machine shown on the nomenclature plate. See page 2.
2. Parts number (s) and description (s) here.

When ordering by mail, prices will be furnished on request, or parts will be shipped at prevailing prices and you will be billed accordingly.

Ref. No.	Part No.	Description	Ref. No.	Part No.	Description
1	28775	Shuttle hook (Model 54)	10	1106	Pattern disc No. 6A and B
	11082	Shuttle hook (Model 16, 1749)		1107	Pattern disc No. 7A and B
2	13480	Needle clamp (Model 16, 54)		1108	Pattern disc No. 8A and B
	26929	Needle clamp (Model 1749)		1109	Pattern disc No. 9A and B
3	*6862	10 bobbins in case		1110	Pattern disc No. 10A and B
4	6510	Bobbin case		1111	Pattern disc No. 11A and B
5	6797	Light bulb		1112	Pattern disc No. 12A and B
6	*6745	Double needle		1113	Pattern disc No. 13A and B
	*6550	No. 9 needles	11	1222	Bobbin winder tension disc
	*6551	No. 11 needles	12	135	Presser foot thumb screw (Model 54)
	*6552	No. 14 needles		9309	Presser foot thumb screw (Model 16, 1749)
	*6553	No. 16 needles			
	*6554	No. 18 needles	13	11191	Clamping shank (Model 16, 1749)
7	1939	Bobbin winder rubber ring	14	40390	Standard zigzag foot (Model 54)
8	2273	Nylon disc	15	3331	Standard zigzag foot (Model 1749)
9	8286	Spool pin		27678	Standard zigzag foot (Model 16)
10	1081	Pattern disc No. 1A and B	16	3330	Satin stitch foot (Model 1749)
	1102	Pattern disc No. 2A and B		27676	Satin stitch foot (Model 16)
	1103	Pattern disc No. 3A and B	17	3342	Plastic zigzag foot (Model 1749)
	1119	Pattern disc No. 4A and B		27672	Plastic zigzag foot (Model 16)
	1104	Pattern disc No. 4A and B (Model 540, 541 only)	18	3343	Plastic satin stitch foot (Model 1749)
	1105	Pattern disc No. 5A and B		27673	Plastic satin stitch foot (Model 16)
			19	6872	Straight stitch foot (Model 1749)

<u>Ref. No.</u>	<u>Part No.</u>	<u>Description</u>	<u>Ref. No.</u>	<u>Part No.</u>	<u>Description</u>
20	27674	Straight stitch foot (Model 16)	28	8939	1-1/16" keyhole template
21	27677	Plastic straight stitch foot (Model 16)		8940	1-1/16" regular template
22	27679	Gathering foot (Model 16, 1749)		8941	13/16" regular template
23	6914	Motor belt		8942	5/8" regular template
24	6864	Needle threader		1293	5/16" regular and eyelet template
25	55501	Large screw driver		9021	15/16" regular template
	55500	Small screw driver		9022	1/2" regular template
26	35083	Buttonhole cover plate (Model 54)		9023	3/8" regular template
	36214	Buttonhole cover plate (Model 16, 1749)		9020	5/8" keyhole template
27	35083	Buttonhole guide plate (Model 54)	29	6830	Buttonhole opener
	28845	Buttonhole guide plate (Model 16, 1749)	30	*6889	Oiler-brush combination

\*These items are not furnished with the machine, but may be ordered per instructions above.

## SEWING MACHINE

Now that you have purchased your Sewing Machine, should a need ever exist for repair parts or service, simply contact any Sears Service Center and most Sears, Roebuck and Co. or Simpsons-Sears Limited Stores. Be sure to provide all pertinent facts when your call or visit.

The model number of your Sewing Machine will be shown on your nomenclature plate on the front side of bedplate of your Sewing Machine. See page 2 for location.

WHEN ORDERING REPAIR PARTS, ALWAYS GIVE THE FOLLOWING INFORMATION:

\*MODEL NUMBER    \*NAME OF ITEM    \*PART DESCRIPTION

If the parts you need are not stocked locally, your order will be electronically transmitted to a Sears Repair Parts Distribution Center for handling.

**SEARS, ROEBUCK AND CO., Chicago, IL 60684 U.S.A. and  
SIMPSONS-SEARS LIMITED, Toronto, Ontario, Canada**