

Vacuum Brake Bleeder Kit with Refilling Bottle

User Manual

Read Carefully Before Use
Keep for Future Reference



OMT
Orion Motor Tech

UM-BBT-0046-V1

Disclaimer

Read this disclaimer completely and carefully before proceeding with the rest of the manual content.

1. Product Modifications

Any modifications or alterations to Orion Motor Tech (OMT) products void any warranties and may result in damage or injury. OMT shall not be liable for any damages resulting from such modifications or alterations.

2. Compliance with Laws

Customers shall be liable for ensuring that the use of OMT products complies with all applicable laws and regulations in their respective jurisdictions. OMT shall not be responsible for any violations of laws or regulations resulting from the use of OMT products.

3. Correct Use

Always use OMT products only as directed in the accompanying manuals. Failure to follow instructions may result in injury or damage.

Always ensure the assembly, installation, operation, maintenance, or repair of OMT products is carried out by a competent person.

Regular maintenance should be performed throughout the lifecycle of OMT products. You are responsible for ensuring the products operate as intended.

Always wear appropriate protective gear.

4. Third-Party Products

OMT shall not be liable for any damages or losses resulting from the use of third-party products in conjunction with OMT products. Customers shall refer to the third-party's guidelines and/or warranties (if any) for any third-party products used.

5. Limitation of Liability

OMT shall not be liable for any direct, indirect, punitive, incidental, special, or consequential damages to property or life, whatsoever arising out of or connected with the use or misuse of OMT products. In no event shall OMT's liability exceed the value of the products sold.

6. Warranty

Refer to the sales page for warranty information.

This disclaimer states the entire obligation of OMT with respect to OMT products. If any part of this disclaimer is determined to be void, invalid, unenforceable, or illegal, including but not limited to the warranty disclaimers, liability disclaimers, and liability limitations set forth above, the invalid or unenforceable provision will be deemed superseded by a valid and enforceable provision that most closely matches the intent of the original provision and the remainder of the agreement shall remain in full force and effect.

@OrionMotorTech



Safety Information

Danger

- Read these instructions carefully before use.
- Store this manual for future reference. Include this manual with the kit if it is ever given or sold to a third party.
- **ONLY** use this kit for its intended purpose: draining air from the braking system and replacing old brake fluid.
- **ONLY** use this kit according to these instructions, the vehicle manufacturer's guidelines, and all applicable local and national laws and regulations. Improper use may cause fires, explosions, serious property damage, or severe personal injury, including death.
- **ONLY** trained personnel should use this kit. Vehicle maintenance can be dangerous and must be done carefully and responsibly.
- **DO NOT** allow children or anyone with impaired mental or physical capabilities to use this kit.
- **DO NOT** use it while under the influence of alcohol, drugs, or any medication that negatively affects your judgment or reflexes.
- **NEVER** use this kit for or around highly flammable, corrosive, or explosive fluids and gases such as gasoline, strong acids, and brake fluids.
- **NEVER** smoke or allow open flames around flammable or explosive fluids and gases.
- Keep your work site clean and well-lit. Cluttered and dark work areas invite accidents.
- Keep your work site well-ventilated. **NEVER** run your vehicle's engine in a tightly enclosed space. **IMMEDIATELY** stop the engine and improve ventilation if you experience eye, nose, or throat irritation during work.
- **ALWAYS** review and understand your vehicle's safety warnings and instructions before using this kit. Use the correct fluids, pressures, adapters, etc., for your vehicle. Ensure your vehicle is securely parked or held in place before beginning any work.
- **NEVER** touch any heated surface or fluid with exposed skin.
- **NEVER** open a cap such as those on a radiator or expansion tank if it could release hot or pressurized fluid or vapor.

Warning

- For best results, keep the kit clean and dry. Remove any fluid, oil, or grease before and after work, particularly from the handle and fittings. Maintain the product's labeling. Contact customer service if replacements are needed.
- **ONLY** use this kit with personal protective equipment (PPE) appropriate for your work. Always wear ANSI-approved eye and hand protection while using this kit. Nonslip footwear is highly recommended. Ear, head, and body protection may also be necessary, depending on your work and other equipment. Keep unprotected bystanders at a safe distance.
- Dress properly for your work. **DO NOT** wear loose clothing or jewelry. Keep hair, clothing, gloves, hoses, and tools away from any moving parts during use.
- **DO NOT** overreach. Keep proper footing and balance at all times.
- **DO NOT** use excessive pressure with this kit, and **DO NOT** force it or its attachments.
- Maintain this kit properly, and keep it dry and clean after use. Check for misalignment or binding of parts, wear or breakage, or any other issues that could affect this kit's safe operation. In the event of damage or malfunction, ensure that affected part(s) are repaired or replaced by a trained technician before continued use. In a large workshop, mark such tools as "**DO NOT USE**" until they are repaired. Only replace parts with identical components.
- **DO NOT** pour waste brake fluid down the drain, into a drain outlet, or into the soil to avoid contaminating the environment.
- Disposal regulations for hazardous waste may vary by region. Before disposing of used brake fluid, it is advisable to consult your local government or environmental protection department for local waste disposal regulations.

Specifications

Vacuum Brake Bleeder	Material	PP, Nylon, Aluminum, Pure Copper, and Q235	
	Capacity	3.17 qt (0.79 gal)	3 L
	Air Valve Inlet Dia.	0.24 in	6 mm
	Dimensions	10.2 × 10 × 7.9 in	26 × 25.5 × 20 cm
Refilling Bottle	Material	PP, PE, Pure Copper, and Q235	
	Capacity	1.06 qt (0.26 gal)	1 L
	Dimensions	11.2 × 4.3 × 4.5 in	28.5 × 11 × 11.5 cm
Hose Lengths		72.4 in	184 cm
		69.5 in	177 cm
		2.8 in	7 cm
Net Weight		3.66 lb	1.66 kg

Package List

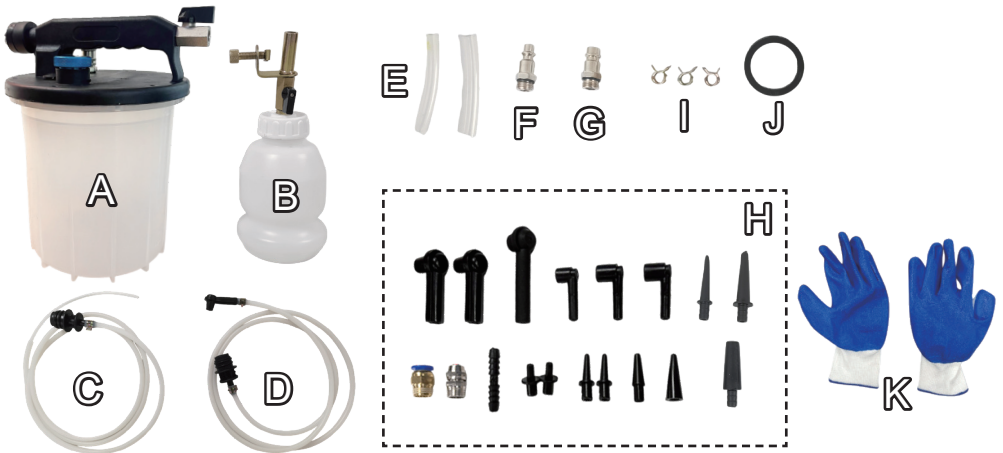

No.	Name	Qty.
A	Vacuum Brake Bleeder	1
B	Refilling Bottle	1
C	Extractor Hose	1
D	Bleeding Hose	1
E	Tubes	2
F	American Air Intake	1

No.	Name	Qty.
G	European Air Intake	1
H	Bleed Screw Adapters	18
I	Hose Clamps	3
J	Rubber Ring	1
K	Gloves	1 (Pair)

Not Included but Helpful: Box-End Wrench

Product Diagram

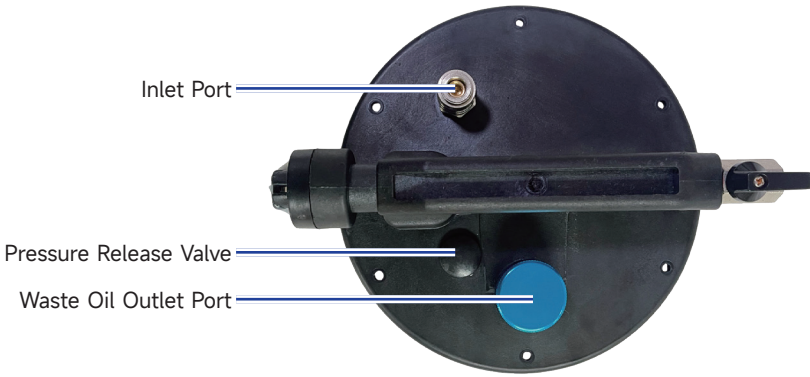

Operation

Warning

- **ALWAYS** follow your vehicle manufacturer's service manual for the recommended type and amount of transmission fluid.
- Put on your PPE, always including ANSI-approved safety glasses and work gloves.
- Raise your vehicle if needed, using appropriate safety stands to prevent potentially fatal accidents.
- **ALWAYS** ensure that the brake fluid to be added matches your vehicle's specific requirements to prevent damage to the braking system.
- **DO NOT** open the vacuum brake bleeder's pressure release valve during use. Doing so will introduce air into the system, causing reduced efficiency, malfunction, or even safety hazards like explosions.
- **ALWAYS** work in a well-ventilated area, as brake fluid can emit harmful vapors.

Extracting the Old Brake Fluid

1. Ensure that the vehicle is turned off. Turn it to Neutral for manual transmissions, or turn it to Park for automatic transmissions. Activate the parking brake.
2. Choose an air intake (F or G) and securely connect it to the air valve inlet on the vacuum brake bleeder.
3. Secure the extractor hose (C) to the inlet port.
4. Remove the cap from the master cylinder reservoir and insert the extractor hose.
5. Connect an air compressor to the air valve inlet on the brake bleeder and set the compressor. The recommended pressure range is 70 – 170 psi (4.8 – 11.7 bar).
6. Turn on the air control valve and activate the air compressor to extract the old fluid.
7. After extraction, remove the extractor hose, switch off the air compressor, and turn off the air control valve.

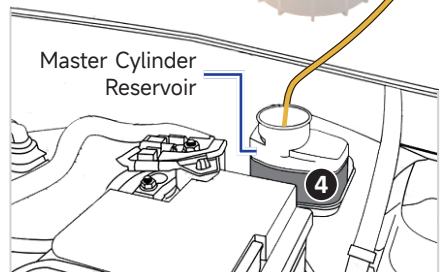

Air Control Valve OFF



Air Control Valve ON

Adding the New Brake Fluid

1. Unscrew the refilling bottle's cap, fill the new brake fluid into the bottle, and retighten the cap.
2. Fix the refilling bottle on the reservoir by tightening the swivel clamp clockwise.
3. Turn on the switch valve and start filling.

Note

ALWAYS keep the reservoir filled to prevent air from entering the brake system.

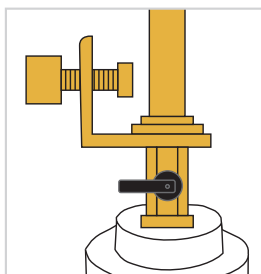
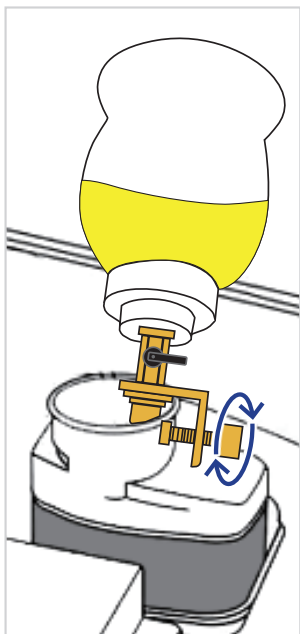

Switch Valve OFF

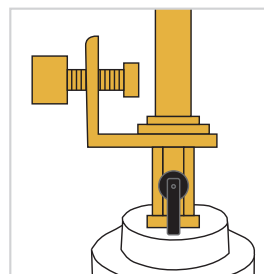

Switch Valve ON

Bleeding the Brake Fluid

1. Remove the extractor hose and connect the bleeding hose (D) to the inlet port.
2. Locate the tire farthest from the reservoir and identify the bleed screw near it.
3. Remove the bleed screw cap and attach the bleeding hose with the adapter to the screw.
4. Use a box-end wrench (not included) to loosen or open the bleed screw.

5. Keep the air compressor connected and set it within the recommended pressure range of 70 – 170 psi (4.8 – 11.7 bar).
6. Turn on the air control valve and activate the air compressor to bleed the brake fluid.

Note

Old brake fluid is extracted while new brake fluid is added at the same time.

7. Continue bleeding the old brake fluid until you see new, cleaner brake fluid being extracted. (The new fluid is lighter in color.)

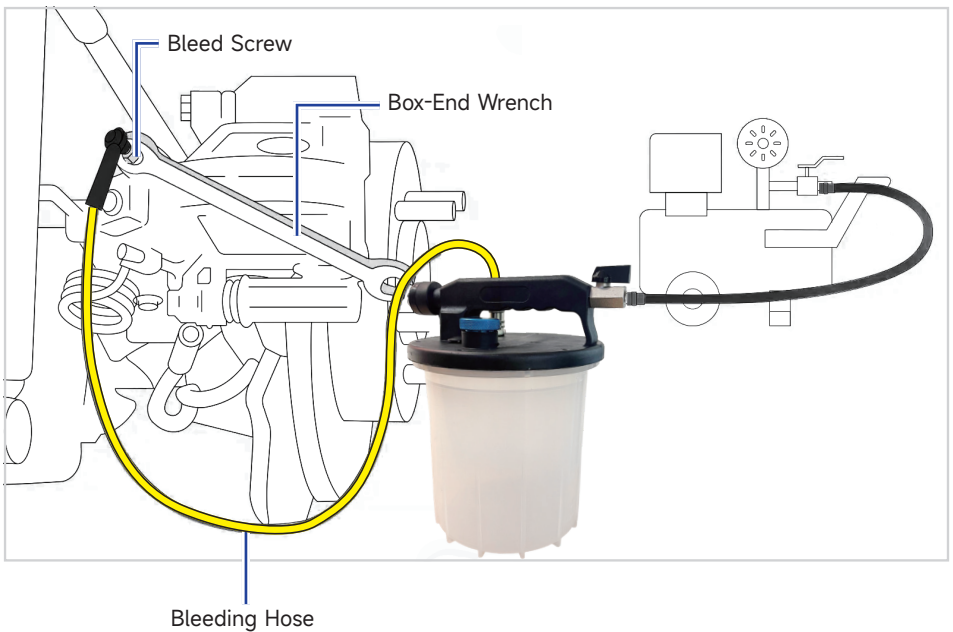
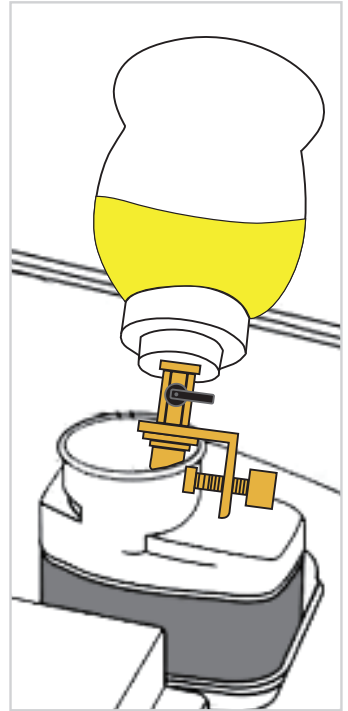

- Start from the tire farthest from the reservoir to the one nearest to it. Repeat the process for each wheel in succession.

Note

While the fluid is being changed, regularly check the level in the refilling bottle.

- After bleeding, switch off the air compressor and disconnect it from the brake bleeder. Remove the bleeding hose from the inlet port. Unscrew the blue cap of the waste oil outlet port and pour the old brake fluid from the outlet port into the waste oil barrel.

**Danger**

- ALWAYS** wear proper PPE, such as gloves and goggles, when handling waste brake fluid to prevent exposure to hazardous substances.
- Hazardous waste disposal regulations vary by region and require spent brake fluid to be disposed of according to local standards.
- NEVER** mix waste brake fluid with other chemicals as this may cause a dangerous chemical reaction.
- Ensure that waste brake fluid is stored in sealed containers away from sources of ignition and children to prevent accidents.

Maintenance

- Use detergent and water to rinse the kit and clean the inner surfaces of the hoses. Dry the kit **COMPLETELY** before continued use.
- Check for loose connections, wear, and damage before and after each use. Tighten, repair, or replace **ANY** affected or damaged components before further use. **ONLY** use identical parts as replacements.
- If this kit will not be used for an extended period, store it in a cool and dry location, away from direct sunlight and out of children's reach.

Troubleshooting

Problems	Solutions
Slow Extraction Speed	Check for blockages or obstructions in the tubes; Clean or replace any blocked components.
	Verify the air pressure source to ensure it is within the specified range for the equipment.
	Inspect the hoses for twists or bends that may affect flow speed.
Leakage Issues	Check the tightness of hose connections to ensure there are no loose fittings.
	Inspect the hoses, tubes, adapters, clamps, and other components for damage or wear; Promptly replace any affected or damaged components.
	Ensure that the clamps are securely fastened to the hose connections.
Air Remaining in the Brake System	Ensure to start bleeding from the wheel farthest from the brake master cylinder and work your way closer.
	Ensure there are no damaged or loose hoses. Tighten all connections securely.
	Problems with brake pads or discs can indirectly affect the bleeding process. Ensure all brake components are in good condition.
Refilling Bottle Not Functioning Properly	Ensure the refilling bottle is properly sealed without any cracks or deformations.
	Verify that the brake fluid can flow freely from the refilling bottle to the master cylinder. Check for any blockages.

We care about your experience!

We truly hope our product brings you joy and convenience.

If you have any questions or need assistance, please don't hesitate to reach out.

We're always happy to help!

Simply fill out the form below, take a photo of it (along with any relevant photos or videos if needed), and email it to us. Our service team will respond within 24 hours.

Platform

Amazon eBay Walmart Wayfair Other: _____ (please specify)

Order Information

Order No.: _____

Product: _____

Purchase Date: _____

Your Name: _____

Email: _____

Subject of Inquiry

Your satisfaction means everything to us :)



support@orionmotortech.com



<https://orionmotortech.com/>



User Manual

Rev. 28 Nov. 2025