

Honeywell

Honeywell

Proud Partner

**AMERICAN
LUNG
ASSOCIATION®
THE HEALTH HOUSE®**

envira**caire**
ELITE™

HE225A,B and HE265A,B By-Pass Flow-Through Humidifiers

with

AgION™
ANTIMICROBIAL

OWNER'S GUIDE

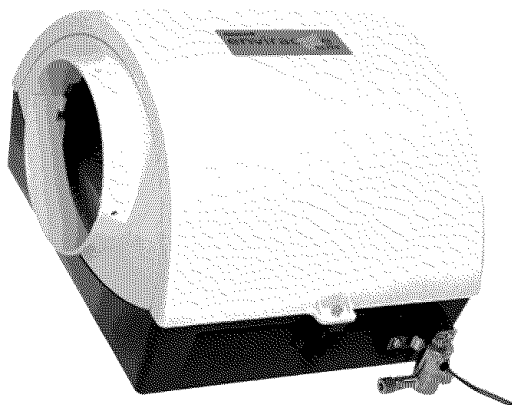

® U.S. Registered Trademark
Copyright © 2003 Honeywell International Inc.
All Rights Reserved

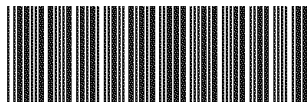

69-1423EF-3

American Lung Association® Health House® Program and Honeywell Working Together For Better Air

Did you know that the average person breathes 3400 gallons(12,870 liters) of air each day * and spends 90% of that day inside?*

Indoor air quality products from Honeywell are designed to help make your home more comfortable—from zoning products that allow you to control the temperature in individual areas of the home to humidifiers and comfort control centers that help balance the moisture content of your indoor air.

Honeywell is proud to be a partner of the American Lung Association® Health House® program that provides guidelines for constructing homes with improved air quality and ventilation.

For more information on ways to improve the air inside your home, please visit the Health House website at:

www.healthhouse.org

and the American Lung Association website at: www.lungusa.org

The American Lung Association and its Health House program do not endorse products.

For more information about Honeywell Indoor Air Quality products, visit:

www.honeywell.com/yourhome

or call:

1-800-345-6770 x531

*EPA.National Air Quality 1999 Status & Trends.

***Indoor Air Pollution, An Introduction for Health Professionals*, EPA, US Government Printing Office #1994-523-217/81322.

IMPORTANT

Please read these instructions and keep them in your records.

OPERATING YOUR HUMIDIFIER

HE225A,HE265A

Your Enviracaire Elite™ HE225A and HE265A Humidifiers from Honeywell are controlled by the H8908B Convertible Humidity Control. The convertible humidity control is installed either on an interior wall in the living area, or on the return air duct. Choose the humidity control setting using the combination relative humidity/outdoor temperature setting scale on your humidity control dial. Match the dial setting to the outdoor temperature for optimizing the humidity level while reducing moisture condensation on your windows. The table below can also be used to adjust humidity control to the recommended setting.

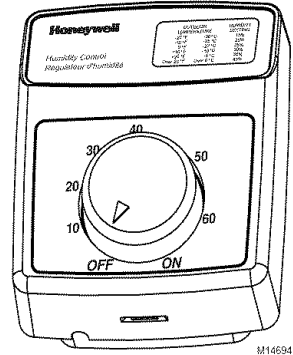

M14694

At Outside Temperature	Recommended Control Setting	At Outside Temperature	Recommended Control Setting
-20°F (-29°C)	15	+10°F (-12°C)	30
-10°F (-23°C)	20	+20°F (-7°C)	35
0°F (-18°C)	25	Above 20°F (-7°C)	40

NOTE: As outside temperature drops, the recommended humidity control setting is lowered to adjust for effects of dewpoint. These settings should reduce accumulation of moisture and ice on your windows and other areas of your home.

Some indoor activities such as cooking, showering and clothes drying can cause excessive levels of humidity and start the accumulation of moisture on your windows.

NOTE: If this condition persists for more than a few hours, set the humidity control to the lowest setting to turn off the humidifier. If the condition does not improve, ventilate your home to remove the moisture.

HE225B,HE265B

Your Enviracaire Elite™ HE225B and HE265B Humidifiers are controlled by the Honeywell H1008 Automatic Humidity Control with HumidCalc+™. The automatic humidity control is mounted in the return air duct where it can be exposed to the air stream of the return air.

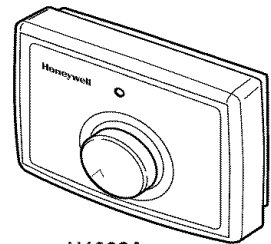

H1008A

M12817

The HumidCalc+™ software inside your automatic humidity control is designed to measure or infer outdoor temperature and automatically adjust the humidity based on the frost factor setting that the homeowner sets to allow for variances in furnace size, window type and insulation.

The Automatic Humidity Control with HumidCalc+™ requires an initial adjustment period. For maximum humidification, set the H1008 to 10 and run the fan continuously. Check for condensation on windows after a cold night. If there is no condensation, leave the setting at 10. If there is condensation, lower the frost factor dial one setting. Continue to check for condensation on cold mornings until the correct humidity setting is reached for your home. Allow two days between adjustments to determine if further adjustment is necessary. Once you have tuned in the proper setting, you should never have to adjust it again. HumidCalc+™ takes over and makes any future adjustments caused by varying outdoor temperatures, thus reducing moisture build-up on windows while maintaining the optimal humidity level.

Humidity Level	Recommended Setting
Insufficient humidity	Increase the frost factor dial by one setting.
Condensation on windows	Decrease the frost factor dial by one setting.

HOW YOUR HUMIDIFIER WORKS

Your Enviraicare Elite™ humidifier uses the principle that vapor (evaporated water) is created when warm air blows over a water soaked area. As the vapor circulates, the relative humidity rises.

Your humidity control monitors the relative humidity and activates the humidifier accordingly. The humidifier has a water supply that dispenses water evenly over the AgION™ antimicrobial humidifier pad. The warm dry air, from the furnace, passes over the humidifier pad and picks up the moist air to circulate it throughout your home.

Humidified air feels warmer and more comfortable so you may be able to lower your thermostat heating setpoint, which saves money on your heating fuel bills. The end result is that your humidifier gives you a cleaner, more comfortable environment that is also energy efficient.

MAINTAINING YOUR HUMIDIFIER

.A regular maintenance program prolongs the life of your humidifier and provides a more comfortable home. Frequency of cleaning depends on the condition of your water. You can use either hard or soft water in your humidifier, but hard water mineral deposits are more difficult to clean than soft water deposits. For optimum performance, Honeywell recommends replacing the AgION™ antimicrobial pad once a year. Use the following procedure to clean your Honeywell humidifier.

! WARNING

Serious Personal Injury Hazard.
Can cause electrical shock and injury from moving parts.
 Disconnect power and shut off water supply before removing cover.

IMPORTANT

Never oil any part of the humidifier.

Every 1 to 3 Months (Depending on Water Quality)

1. Disconnect power and turn off humidifier water supply.
2. Remove the humidifier cover by unplugging the connector and loosening the thumb screw. Grasp the cover near the bottom and pull toward you.
3. Remove humidifier pad assembly from humidifier by grasping top of tray and pulling it toward you.
4. Lift the tray off the pad.
5. Gently pinch water nozzle catches inward until you can lift water nozzle off tray.
6. Carefully remove any mineral deposits from tray and frame. Be sure frame drain hole is not blocked.
7. Disconnect drain hose from drain fitting on the bottom of the humidifier housing.
8. Clean the drain fitting, if necessary.
9. Bend the drain hose to loosen any mineral deposits.
10. Flush the drain hose with pressurized water (a running tap) to clean the hose.
11. Reattach the drain hose to the drain fitting.
12. Snap the water nozzle back on the tray.
13. Be sure the marked end of the pad is facing up. Place the tray on the new pad.
14. Place humidifier pad assembly in humidifier housing. Be sure water feed tube is placed in guide slots.
15. Replace the humidifier cover.
16. See **Checking Your Humidifier for Proper Operation** section to verify operation.

End of Humidification Season

Clean the humidifier and shut it off at the end of the heating season. See **Every 1 to 3 Months** section, steps 1 through 15, to shut down for the season.

IMPORTANT

Be sure humidifier power is off.

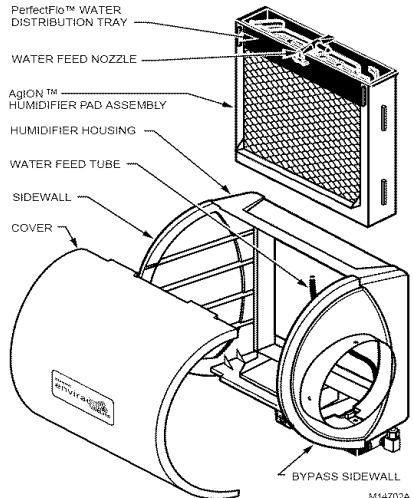

Vacation

The humidifier water supply and your humidity control can be turned off. Turn on humidifier water supply and reset your humidity control when you return.

CHECKING YOUR HUMIDIFIER OPERATION

After winter startup or servicing, check the humidifier operation:

1. Turn on the humidifier power and water supply.
2. Turn H8908B Control to highest setting or H1008A Control to test position; set thermostat to 10°F (6°C) above room temperature.

NOTE: The H1008A Automatic Humidity Control stays in test mode for thirty minutes. Then it automatically resets to the maximum frost factor setting. If system checkout is not completed in thirty minutes, test mode can be extended by turning dial setting back and then returning it to test mode.

3. Observe that water is flowing out of the drain hose.

NOTE: The furnace blower must be on to activate the humidifier.

4. Reset thermostat and H8908A Control to comfortable setting or H1008A Automatic Control to desired frost factor setting for automatic operation.

TROUBLESHOOTING YOUR HUMIDIFIER

Problem	What to Look for	What to Do
Low humidity	Furnace blower not operating.	<ul style="list-style-type: none"> •Reset circuit breaker or replace fuse. •Check that the furnace power is on. •Check all external wiring connections. •Check humidity control setting. •Call a heating contractor.
	Rapid air changes. Drafts (cold air is dry and is an added load to humidifier).	<ul style="list-style-type: none"> •Keep doors and windows closed. •Close fireplace damper if not using. •Minimize exhaust fan running time. •Seal around doors and windows.
High humidity	Condensation on walls.	•Turn off humidity control and water until condensation is completely evaporated.
	Heavy condensation on windows.	•Turn humidity control low enough to eliminate bath and cooking condensation moisture. If moisture persists, more ventilation is needed.

ADDING PERFECT CLIMATE® CONTROLS FOR COMFORT AND CONVENIENCE

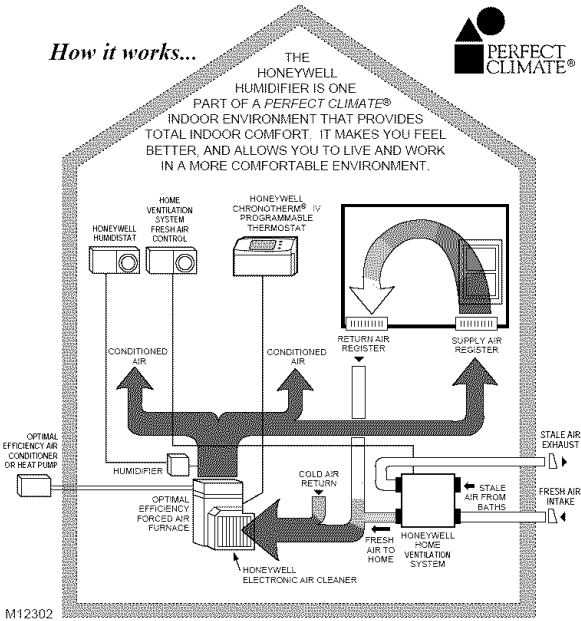

1. Honeywell Perfect Climate Comfort Center™ controls or Chronotherm® IV Programmable Thermostats.
2. Honeywell media air cleaner or electronic air cleaners.
3. Honeywell humidistats.
4. Honeywell home ventilation systems.

Describing Perfection

The cleanest, healthiest, most convenient, energy efficient, and comfortable indoor environment possible today! Perfect climate is achieved when the following five core components of a home's climate system work together:

- optimal efficiency heating and cooling equipment,
- precise, programmable temperature control,
- effective indoor air quality control,
- controlled humidity,
- proper ventilation and air distribution.

Contact your local Perfect Climate® dealer for an evaluation of your home.

WARRANTY

Honeywell warrants this product, excluding humidifier pad, to be free from defects in the workmanship or materials, under normal use and service, for a period of one (1) year from the date of purchase by the consumer. If, at any time during the warranty period, the product is defective or malfunctions, Honeywell shall repair or replace it (at Honeywell's option) within a reasonable period of time.

If the product is defective, return it, with a bill of sale or other dated proof of purchase, to the place where you purchased it.

This warranty does not cover removal or reinstallation costs. This warranty shall not apply if it is shown by Honeywell that the defect or malfunction was caused by damage which occurred while the product was in the possession of a consumer.

Honeywell's sole responsibility shall be to repair or replace the product within the terms stated above. HONEYWELL SHALL NOT BE LIABLE FOR ANY LOSS OR DAMAGE OF ANY KIND, INCLUDING ANY INCIDENTAL OR CONSEQUENTIAL DAMAGES RESULTING, DIRECTLY OR INDIRECTLY, FROM ANY BREACH OF ANY WARRANTY, EXPRESS OR IMPLIED, OR ANY OTHER FAILURE OF THIS PRODUCT. Some states do not allow the exclusion or limitation of incidental or consequential damages, so this limitation may not apply to you.

THIS WARRANTY IS THE ONLY EXPRESS WARRANTY HONEYWELL MAKES OTHIS PRODUCT. THE DURATION OF ANY IMPLIED WARRANTIES, INCLUDING THE WARRANTIES OF MERCHANTABILITY AND FITNESS FOR A PARTICULAR PURPOSE, IS HEREBY LIMITED TO THE ONE YEAR DURATION OF THIS WARRANTY. Some states do not allow limitations on how long an implied warranty lasts, so the above limitation may not apply to you.

This warranty gives you specific legal rights, and you may have other rights which vary from state to state.

If you have any questions concerning this warranty, please write Honeywell Customer Care, 1985 Douglas Dr N, Golden Valley, MN 55422 or call 1-800-468-1502. In Canada, write Retail Products, ON15, Honeywell Limited/Honeywell Limitée, 35 Dynamic Dr, Scarborough, Ontario M1V 4Z9.

Honeywell

Automation and Control Solutions

Honeywell International Inc.
1985 Douglas Drive North
Golden Valley, MN 55422

Honeywell Limited-Honeywell Limitée
35 Dynamic Drive
Scarborough, Ontario
M1V 4Z9



Printed in U.S.A. on recycled paper containing at least 10% post-consumer paper fibers.