

Microwave Oven

Four Á Micro-ondes

Horno Microondas

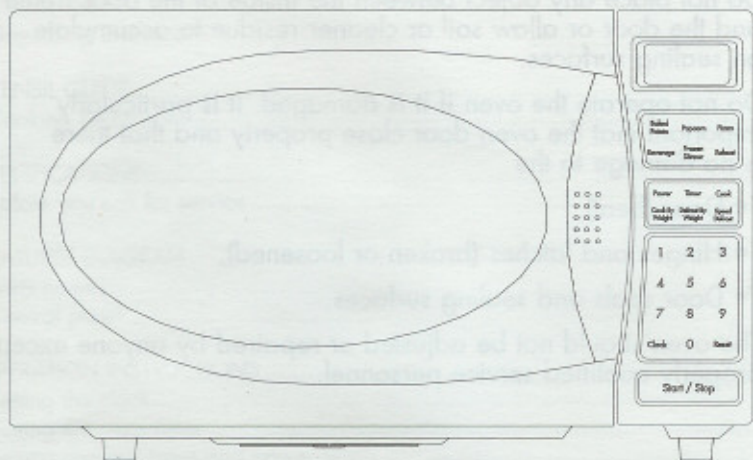

User Manual

Model # SM900WH / SM900BL

Guide de l'Utilisateur

Modèle # SM900WH / SM900BL

Manual del Usuario

Para Modelo de # SM900WH / SM900BL

Before operating this oven, please read these instructions completely.

Avant d'utiliser ce four, veuillez lire les instructions suivantes complètement.



SAFETY PRECAUTIONS

PRECAUTIONS TO AVOID POSSIBLE EXPOSURE TO EXCESSIVE MICROWAVE ENERGY

1. Do not attempt to operate this oven with the door open since open door operation can result in harmful exposure to microwave energy. It is important not to defeat or tamper with the safety interlocks.
2. Do not place any object between the inside of the door frame and the door or allow soil or cleaner residue to accumulate on sealing surfaces.
3. Do not operate the oven if it is damaged. It is particularly important that the oven door close properly and that there is no damage to the
 - Door (bent),
 - Hinges and latches (broken or loosened),
 - Door seals and sealing surfaces.
4. The oven should not be adjusted or repaired by anyone except properly qualified service personnel.

Table Of Contents

	page
SAFETY PRECAUTIONS	1
Precautions to avoid possible exposure to excessive microwave energy.....	1
IMPORTANT SAFETY INSTRUCTIONS.....	3
INSTALLATION	5
Grounding instructions	5
UTENSIL GUIDE.....	6
Cooking Techniques	8
SPECIFICATIONS.....	9
Before you call for service	9
FEATURES DIAGRAM.....	10-11
Parts names	10
Control panel.....	11
OPERATION INSTRUCTIONS	12-14
Setting the clock.....	12
Setting the oven timer	12
Setting cooking times and power levels.....	12
Setting "Speed Defrost"	13
Setting "Cooking by Weight"	13
Setting "Defrost by Weight"	14
Setting "Safety Lock"	14
ABOUT "QUICK COOK" SETTINGS	15-16
Setting "Popcorn"	15
Setting "Pizza"	15
Setting "Baked Potato"	15
Setting "Beverage".....	16
Setting "Frozen Dinner".....	16
Setting "Reheat"	16
FOOD FACTS IN MICROWAVE COOKING	17
CLEANING AND CARE.....	18
TROUBLESHOOTING	19
LIMITED WARRANTY	20

IMPORTANT SAFETY INSTRUCTIONS

When using electrical appliances, basic safety precautions should be followed, including the following:

WARNING - To reduce the risk of burns, electric shock, fire, injury to persons or exposure to excessive microwave energy:

1. **Read all instructions before using the appliance.**
2. Read and follow the specific "PRECAUTIONS TO AVOID POSSIBLE EXPOSURE TO EXCESSIVE MICROWAVE ENERGY" on page 1.
3. This appliance must be grounded. Connect only to properly grounded outlet. See "GROUNDING INSTRUCTIONS" on page 5.
4. Install or locate this appliance only in accordance with the provided installation instruction on page 5.
5. Some products such as whole eggs and sealed containers – for example, closed glass jars – are able to explode and should not be heated in this oven.
6. Use this appliance only for its intended use as described in this manual. Do not use corrosive chemicals or vapors in this appliance. This type of oven is specifically designed to heat, cook, or dry food. It is not designed for industrial or laboratory use.
7. As with any appliance, close supervision is necessary when used by children.
8. To reduce the risk of fire in the oven cavity:
 - a. Do not overcook food. Carefully attend appliance when paper, plastic, or other combustible materials are placed inside the oven to facilitate cooking.
 - b. Remove wire twist-ties from paper or plastic bags before placing bag in oven.
 - c. **If materials inside the oven ignite, keep oven door closed, turn oven off, and disconnect the power cord or shut off power at the fuse or circuit breaker panel.**
 - d. Do not use the cavity for storage purposes. Do not leave paper products, cooking utensils or food in the cavity when not in use.
9. Liquids, such as water, coffee, or tea, are able to be overheated beyond the boiling point without appearing to be boiling due to surface tension of the liquid. Visible bubbling or boiling when the container is removed from the microwave oven is not always present. **THIS COULD RESULT IN VERY HOT LIQUIDS SUDDENLY BOILING OVER WHEN A SPOON OR OTHER UTENSIL IS INSERTED INTO THE LIQUID.**
To reduce the risk of injury to person:
 - a. Do not overheat the liquid.
 - b. Stir the liquid both before and halfway through heating it.
 - c. Do not use straight-sided containers with narrow necks.

- d. After heating, allow the container to stand in the microwave oven for a short time before removing the container.
- e. Use extreme care when inserting a spoon or other utensil into the container.
10. Do not heat oil or fat for deep-frying. It is difficult to control the temperature of oil in microwave oven.
11. Pierce foods with heavy skins such as potatoes, whole squash, apples and chestnuts before cooking.
12. The contents of feeding bottles and baby jars should be stirred or shaken and the temperature should be checked before serving in order to avoid burns.
13. Cooking utensils may become hot because of heat transferred from the heated food. Potholders may be needed to handle the utensil.
14. Do not cover or block any openings on the appliance.
15. Do not store or use this appliance outdoors. Do not use this product near water, for example, near a kitchen sink, in a wet basement, near a swimming pool, or similar locations.
16. Do not operate this appliance if it has a damaged cord or a plug, if it is not working properly, or if it has been damaged or dropped.
17. Do not immerse cord or plug in water. Keep cord away from heated surface. Do not let cord hang over edge of table or counter.
18. Use only thermometers that are specifically designed for use in microwave ovens.
19. Be certain the glass tray and roller rings are in place when you operate the oven.
20. When cleaning surfaces where the door meets the oven where it is closed, use only mild, nonabrasive soaps, or detergents applied with a sponge or soft cloth.
21. This appliance should be serviced only by qualified service personnel. Contact nearest authorized service facility for examination, repair, or adjustment.

SAVE THESE INSTRUCTIONS

Thank you for using our Summit product. This easy-to-use manual will guide you in getting the best use of your microwave.

Model Number _____

Serial Number _____

Date of Purchase _____

Remember to record the model and serial number. They are on a label in back of the microwave.

Staple your receipt to your manual. You will need it to obtain warranty service.

Installation

1. Make sure that all the packing materials are removed from the inside of the door.
2. **WARNING:** Check the oven for any damage, such as misaligned or bent door, damaged door seals and sealing surface, broken or loose door hinges and latches, and dents inside the cavity or on the door. If there is any damage, do not operate the oven and contact qualified service personnel.
3. This microwave oven must be placed on a flat, stable surface to hold its weight and the heaviest food likely to be cooked in the oven.
4. Do not place the oven where heat, moisture, or high humidity are generated, or near combustible materials.
5. For correct operation, the oven must have sufficient airflow. Allow 7.9" of space above the oven, 3.9" at back and 2" at both sides. Do not cover or block any openings on the appliance. Do not remove feet.
6. Do not operate the oven without glass tray, roller support, and shaft in their proper positions.
7. Make sure that the power supply cord is undamaged and does not run under the oven or over any hot or sharp surface.
8. The socket must be readily accessible so that it can be easily unplugged in an emergency.
9. Do not use the oven outdoors.

GROUNDING INSTRUCTIONS

This appliance must be grounded. In the event of an electrical short circuit, grounding reduces risk of electric shock by providing an escape wire for the electric current.

WARNING: Improper use of the grounding plug can result in a risk of electric shock.

Electrical Requirements

The oven must be plugged into at least 15 amp, 120 volts, 60 Hz grounded outlet. It is recommended that a separate circuit serving only the oven be provided. The oven is equipped with a 3-prong grounding plug. It must be plugged into a wall receptacle that is properly installed and grounded.

Extension Cord

We do not recommend the use of an extension cord. If it is necessary to use an extension cord, use only a 3-wire extension cord that has a 3 blade grounding plug and a 3-slot receptacle that will accept the plug on the microwave oven. The marked rating of the extension cord must be equal to or greater than the electrical rating of the appliance.

- Notes:
1. If you have any questions about the grounding or electrical instructions, consult a qualified electrician or service person.
 2. Neither the manufacturer nor the dealer can accept any liability for damage to the oven or personal injury resulting from failure to observe the electrical connection procedures.

Radio or TV Interference

Should there be any interference caused by the microwave oven to your radio or TV, move the radio or TV so that it is on a different circuit than the microwave.

Utensils Guide

This section lists which utensils can be used in the microwave, which ones have limited use for short periods, and which ones should not be used in the microwave.

RECOMMENDED

- **Microwave browning dish** - Use to brown the exterior of small items such as steaks, chops, or pancakes. Follow the directions provided with your browning dish.
- **Microwaveable plastic wrap** - Use to retain steam. Leave a small opening for some steam to escape and avoid placing it directly on the food.
- **Paper towels and napkins** - Use for short-term heating and covering; these absorb excess moisture and prevent spattering. Do not use recycled paper towels, which may contain metal and could ignite.
- **Glass and glass-ceramic bowls and dishes** - Use for heating or cooking.
- **Paper plates and cups** - Use for short-term heating at low temperatures. Do not use recycled paper, which may contain metal and could ignite.
- **Wax paper** - Use as a cover to prevent spattering.
- **Thermometers** - Use only those labeled "Microwave Safe" and follow all directions. Check the food in several places. Conventional thermometers may be used on microwave food once the food has been removed from the oven.

LIMITED USE

- **Aluminum foil** - Use narrow strips of foil to prevent overcooking of exposed areas. Using too much foil can damage your oven, so be careful. You should keep distance of 1 inch (2.54cm) between aluminum foil and cavity.
- **Ceramic, porcelain, and stoneware** - Use these if they are labeled "Microwave Safe." If they are not labeled, test them to make sure they can be used safely.
- **Plastic** - Use only if labeled "Microwave Safe." Other plastics can melt.
- **Straw, wicker, and wood** - Use only for short-term heating, such as warming dinner rolls for a few seconds; baskets and bowls may be flammable.

NOT RECOMMENDED

- **Glass jars and bottles** - Regular glass is too thin to be used in a microwave. It can shatter and cause damage and injury.
- **Paper bags** - These are a fire hazard, except for popcorn bags that are designed for microwave use.
- **Styrofoam plates and cups** - These can melt and leave an unhealthy residue on food.
- **Plastic storage and food containers** - Containers such as margarine tubs can melt in the microwave.
- **Metal utensils** - These can damage your oven. Remove all metal before cooking.

NOTE: Should you wish to check if a dish is safe for microwaving, place the empty dish in the oven and microwave on HIGH for 30 seconds. A dish that becomes very hot should not be used.

Cooking Techniques

Your microwave makes cooking easier than conventional cooking, provided you keep these considerations in mind:

Stirring

Stir foods such as casseroles and vegetables while cooking to distribute heat evenly. Food at the outside of the dish absorbs more energy and heats more quickly, so stir from the outside to the center. The oven will turn off when you open the door to stir your food.

Arrangement

Arrange unevenly shaped foods, such as chicken pieces or chops, with the thicker, meatier parts toward the outside of the turntable where they receive more microwave energy. To prevent overcooking, place delicate areas, such as asparagus tips, toward the center of the turntable.

Shielding

Shield food with narrow strips of aluminum foil to prevent overcooking. Areas that need shielding include poultry wing-tips, the ends of poultry legs, and corners of square baking dishes. Use only small amounts of aluminum foil. Larger amounts can damage your oven.

Turning

Turn foods over midway through cooking to expose all parts to microwave energy. This is especially important with large foods such as roasts.

Standing

Foods cooked in the microwave build up internal heat and continue to cook for a few minutes after heating stops. Let foods stand to complete cooking, especially foods such as cakes and whole vegetables. Roasts need this time to complete cooking in the center without overcooking the outer areas. All liquids, such as soup or hot chocolate, should be shaken or stirred when cooking is complete. Let liquids stand a moment before serving. When heating baby food, stir well at removal and test the temperature before serving.

Adding moisture

Microwave energy is attracted to water molecules. Food that is uneven in moisture content should be covered or allowed to stand so that the heat disperses evenly. Add a small amount of water to dry food to help it cook.

Specification

Power Consumption	120V~60Hz, 1200W
Microwave Power	700W
Operation Frequency	2450MHz
Outside Dimensions(WxDxH)	18" x 14-9/16" x 11-5/8"
Oven Cavity Dimensions(WxDxH)	11-13/16" x 11-3/16" x 8-1/8"
Oven Capacity	0.7 Cu. Ft.
Cooking Uniformity	Turntable System (10-5/8")
Net Weight	Approx. 28.4 lbs.

BEFORE YOU CALL FOR SERVICE

If the oven fails to operate:

1. Check to ensure that the oven is plugged in securely. If it is not, remove the plug from the outlet, wait 10 seconds, and plug it in again securely.
2. Check for a blown circuit fuse or a tripped main circuit breaker. If these seem to be operating properly, test the outlet with another appliance.
3. Check to ensure that the control panel is programmed correctly and the timer is set.
4. Check to ensure that the door is securely closed, engaging the door safety lock system. Otherwise, the microwave energy will not flow into the oven

IF NONE OF THE ABOVE RECTIFY THE SITUATION, THEN CONTACT A QUALIFIED TECHNICIAN. DO NOT TRY TO ADJUST OR REPAIR THE OVEN YOURSELF.

Features Diagram

PART NAMES

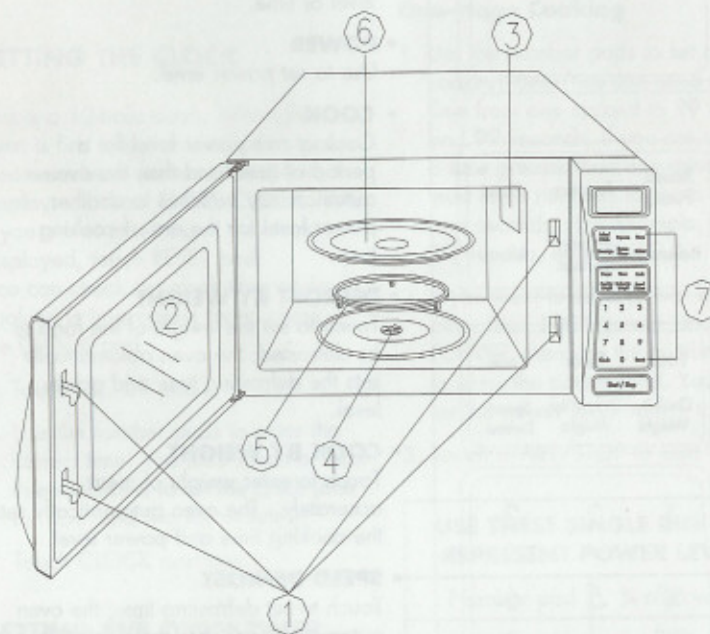

- | | |
|----------------------------|------------------|
| 1. Door Safety Lock System | 5. Roller Ring |
| 2. Oven Door Window | 6. Glass Tray |
| 3. Oven Air Vent | 7. Control Panel |
| 4. Shaft | |

CONTROL PANEL

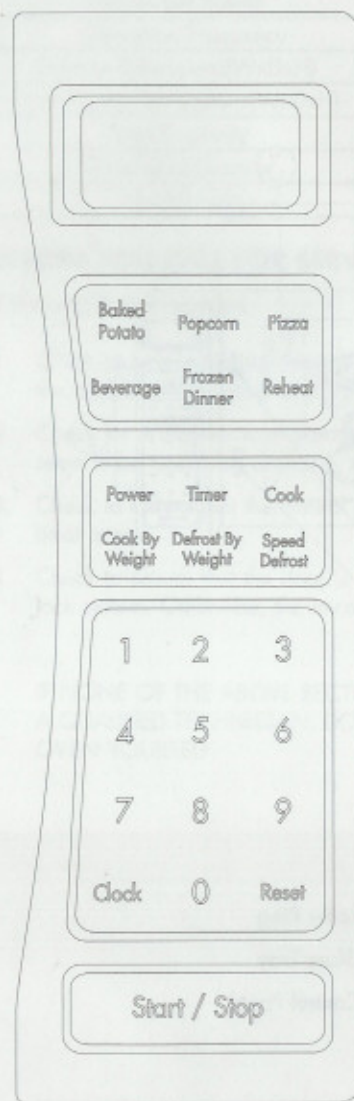

(Please also see the following pages for more detail)

- **DISPLAY**

Cooking time, power, indicators, and present time is displayed.

**BAKED POTATO PIZZA
BEVERAGE POPCORN
FROZEN DINNER REHEAT**

Allows you to reheat or cook food automatically without entering power level or time.

- **POWER**

Use to set power level.

- **COOK**

Cook at one power level for a period of time, and then the oven automatically switches to another power level for the rest of cooking time.

- **DEFROST BY WEIGHT**

Touch to set the weight of the food to be defrosted; the oven automatically sets the defrosting time and power level.

- **COOK BY WEIGHT**

Touch to enter weight of meat accurately. The oven automatically sets the cooking time and power level.

- **SPEED DEFROST**

Touch to set defrosting time; the oven automatically divides the defrosting time into periods of alternating defrost and stand times by cycling on and off.

- **TIMER**

You can use the TIMER function independently, even while a cooking program is going on in the oven.

- **NUMBER PADS (0-9)**

Touch to set times or amounts.

- **CLOCK**

Touch to set the clock.

- **RESET**

Clears all previous settings if touched before cooking starts.

- **START/STOP**

Touch to start or stop cooking.

Operation Instructions

BEEPS DURING OVEN SETTINGS

- **ONE BEEP:** Oven accepts the entry.
- **TWO BEEPS:** Oven does not accept the entry, check and try again.

SETTING THE CLOCK

This is a 12-hour clock. When the oven is first plugged in or when power resumes after a power interruption, the display will show ENTER CLOCK TIME. If you prefer to not have the clock displayed, touch RESET pad.

You can check the clock time while cooking is in progress by touching the CLOCK pad.

1. Touch CLOCK pad.
2. Use the number pads to enter the correct time. You must touch at least three numbers to set the clock (one for hour and two for minutes).
3. Touch CLOCK pad again.

SETTING THE OVEN TIMER

1. Touch TIMER pad.
2. Enter the amount of time you want to count down by touching the number pads. Digit time is in minutes and seconds and set left to right. Set one digit (a 5 for 5 seconds) or up to four digits (2405 for 24 minutes, 5 seconds).
3. Touch START/STOP pad.

NOTE:

1. Time countdown can be seen in display for 3 seconds before clock or cooking time is returned to display.

2. Touch TIMER and then touch RESET to cancel TIMER during timing process.

SETTING COOKING TIMES AND POWER LEVELS**One-stage Cooking**

1. Use the number pads to set a cooking time. You can set a cooking time from one second to 99 minutes and 99 seconds. If you are setting a time greater than one minute, you must enter numbers for both minutes and seconds. For example, to set 20 minutes, enter 2,0,0,0.
2. If you want to set a power level other than 100% power, touch POWER, then use the number pads to enter the power level. You can set the power level from 1 to 9.
3. Touch START/STOP to start cooking.

USE THESE SINGLE DIGIT TO REPRESENT POWER LEVELS

Number pad	% of Power
9	90%
8	80%
7	70%
6	60%
5	50%
4	40%
3	30%
2	20%
1	10%

Two-stage Cooking

Some recipes require different stages of cooking at different temperatures.

1. SET STAGE 1:
Follow steps 1 and 2 in "One-stage cooking." DO NOT TOUCH START/STOP PAD.
2. SET STAGE 2:
Touch COOK pad then enter proper cooking time and (lower) power level. (Most 2-stage recipes use lower power for second stage.)
3. Touch START/STOP pad.

NOTE:

After total time has elapsed, 4 beeps sound and END appears in display. Touch RESET pad or open oven door to clear END before starting another cooking function.

SETTING "SPEED DEFROST"

1. Touch SPEED DEFROST pad.
2. Enter desired defrosting time by touching correct number pads. Digital timer sets minutes and seconds from left to right so a single digit can be set (5 for 5 seconds) or up to 4 digits (2405 for 24 minutes 5 seconds).
3. Touch START/STOP pad.

NOTE:

- After time has elapsed, four beeps sound and END appears in display. Touch RESET pad or open door to clear END before starting another cooking function.
- After setting SPEED DEFROST, oven can be programmed to automatically switch to one or two-stage cooking.

- A. For speed defrost and one stage cooking, follow steps above. Before touching START/STOP pad, touch COOK pad, enter time and power level. Then touch START/STOP pad.
- B. For speed defrost and two stage cooking, follow steps above. Before touching START/STOP pad, enter two-stage cooking programs.

SETTING "COOK BY WEIGHT"

1. Touch COOK BY WEIGHT pad.
2. Enter the one-digit code by touching the correct number pad.
3. Enter weight.
4. Touch START/STOP pad.

NOTE:

- Your microwave oven makes cooking easy. You set the type and weight of food, and the oven automatically sets the cooking time and power level.

"COOK BY WEIGHT" CODE DESCRIPTIONS		
CODE	TYPE	MAX WEIGHT
1	Beef	5lb. 16 oz
2	Mutton	5lb. 16 oz.
3	Pork	5lb. 4 oz.

- Meat must be defrosted and at refrigerated temperature.
- Weight must be in pounds and ounces. Ounce weights less than 10 must be preceded by a 0. If label gives weight in pounds only, change the fraction of a pound to ounces using the following chart.

CONVERTING FRACTIONS OF A POUND TO OUNCES

FRACTIONS OF A POUND	OUNCES
Less than .03	0
.03 to .09	1
.10 to .15	2
.16 to .21	3
.22 to .27	4
.28 to .34	5
.35 to .40	6
.41 to .46	7
.47 to .53	8
.54 to .59	9
.60 to .65	10
.66 to .71	11
.72 to .78	12
.79 to .84	13
.85 to .90	14
.91 to .97	15
Above .97	Go to next even

- Turn meat over when oven beeps twice. Touch START/STOP to resume cooking.
- After total cooking time, 4 beeps sound and END appears in display. Touch RESET or open oven door to clear END before starting another cooking function. Let meat stand few minutes before carving.

SETTING "DEFROST BY WEIGHT"

1. Touch DEFROST BY WEIGHT pad.
2. Enter weight.
3. Touch START/STOP pad.

NOTE:

- Weight must be in pounds and ounces. Ounce weights less than 10 must be preceded by a 0. If label gives weight in pounds only, change the fraction of a pound to ounces using the chart on this page.
- Turn food over when oven beeps twice. Touch START/STOP pad to resume defrosting.
- After total defrosting time, 4 beeps sound and END appears in display. Touch RESET or open oven door to clear END before starting another cooking function.

SETTING "SAFETY LOCK"

The safety lock prevents unsupervised operation by little children. To set, press and hold RESET pad for 3 seconds, LOCK indicator lights to cancel, press and hold RESET pad for 3 seconds, LOCK indicator goes off.

TO STOP THE OVEN WHILE THE OVEN IS OPERATING

1. Touch START/STOP pad.
 - You can restart the oven by touching START/STOP pad.
 - Touch RESET to erase all instructions.
2. Open the door.
 - You can restart the oven by closing the door and touching START/STOP pad.

NOTE:

Oven stops operating when door is opened.

ABOUT "QUICK COOK" SETTINGS

"QUICK COOK" allow you to cook or reheat food automatically without entering power level or time. When setting "quick cook," check visual guide on pad for correct setting. Three "quick cook" settings allow you to cook several amounts of the same food. These include the "FROZEN DINNER," "BAKED POTATO," and "BEVERAGE." After you touch these pads, ENTER AMT appears in the display. In each "Quick Cook" category, touch the pad once for a smaller amount of food. One dot (.) will appear to signify a small amount of food. Touch the pad twice for a larger amount of food. Two dots (..) will appear to signify a large amount of food.

SETTING "POPCORN"

1. Touch POPCORN pad.
CODE and 2:50 (2 min. 50 sec.) appears in the display. POPCORN automatically sets the cooking time for a 3 to 3 1/2 oz. bag of microwave popcorn.
2. Touch START/STOP pad.

NOTE:

To reset POPCORN time: Tap POPCORN pad twice. ENTER TIME appears in display. Touch number pads to enter minutes and seconds. Touch START/STOP pad. This new cooking time will remain whenever you touch the POPCORN pad until you reset it.

SETTING "PIZZA"

Reheating a slice (or two thin ones) of leftover pizza:

1. Touch PIZZA pad once. CODE and 1:20 (1 min. 20 sec.) appears.
2. Touch START/STOP pad.

Heating a whole frozen pizza:

1. Tap PIZZA pad twice. CODE and 6:30 (6 min. 30 sec.) appears.
2. Touch START/STOP pad.

SETTING "BAKED POTATO"

For 3.5 to 5 oz. potatoes:

1. Touch BAKED POTATO pad once.
2. Enter number of potatoes by touching number pads from 1 to 4. Cooking times for small-medium potatoes are as follows:
 - 1 potato: 4 min. 20 sec.
 - 2 potatoes: 8 min. 10 sec.
 - 3 potatoes: 12 min. 00 sec.
 - 4 potatoes: 16 min. 00 sec.
3. Touch START/STOP pad.

For the large 6 to 8 oz. potatoes:

1. Touch BAKED POTATO pad once.
2. Enter number of potatoes by touching number pads from 1 to 4. Cooking times for large potatoes are as follows:
 - 1 potato: 6 min. 25 sec.
 - 2 potatoes: 12 min. 00 sec.
 - 3 potatoes: 17 min. 00 sec.
 - 4 potatoes: 22 min. 00 sec.
3. Touch START/STOP pad.

SETTING "BEVERAGE"

For 4 to 6 oz. coffee cups:

1. Touch BEVERAGE pad once.
2. Enter number of cups by touching number pads from 1 to 4. Cooking times for coffee cups are as follows:
 - 1 cup: 1 min. 30 sec.
 - 2 cups: 2 min. 50 sec.
 - 3 cups: 4 min. 10 sec.
 - 4 cups: 5 min. 30 sec.
3. Touch START/STOP pad.

For larger 7 to 9 oz. coffee mugs:

1. Tap BEVERAGE pad twice.
2. Enter number of mugs by touching number pads from 1 to 4. Cooking times for coffee mugs are as follows:
 - 1 mug: 2 min. 40 sec.
 - 2 mugs: 4 min. 30 sec.
 - 3 mugs: 6 min. 20 sec.
 - 4 mugs: 8 min. 10 sec.
3. Touch START/STOP pad.

SETTING "FROZEN DINNER"

Microwaving one or two small (5-7 oz.) frozen dinners:

1. Touch FROZEN DINNER pad once.
2. For 1 entree, just touch START/STOP. For 2 entrees, touch the number pad "2." Cooking times for small-size entrees are as follows:
 - 1 entree: 5 min. 55 sec.
 - 2 entrees: 11 min. 00 sec.
3. Touch START/STOP pad.

Microwaving one large (8-10 oz.) frozen dinner:

1. Tap FROZEN DINNER pad twice.
2. For 1 entree, just touch START/STOP. For 2 entrees, touch the number pad "2." Cooking times for larger entrees are as follows:
 - 1 entree: 12 min. 00 sec.
 - 2 entrees: 20 min. 00 sec.
3. Touch START/STOP pad.

SETTING "REHEAT"

1. Touch REHEAT pad. CODE and 4:10 (4 min. 10 sec.) appears.
2. Touch START/STOP pad.

NOTE:

This setting lets you reheat a dinner plate of chilled leftovers with good results.

Food Facts in Microwave Cooking

Quality of the food: Poor quality ingredients are rarely improved by any method of cooking and this applies particularly to microwave cooking, as the process is so fast.

Temperature: The colder the food before cooking, the longer it will take to cook.

Quantity: The cooking time relates to the amount of food in the microwave oven. Do not overload the microwave. For very large quantities, it is better and may be quicker to cook in two or more batches.

Density: The more porous the food, the faster it will cook. A light airy cake mixture will cook faster than jacket potatoes.
Size and Shape: Uniform shapes cook more evenly. In an irregular shape, such as a leg of lamb, the thinner parts will cook faster than the thick part. The smaller the individual piece of food is (such as the vegetables in a soup) the quicker the cooking.

Moisture: There is very little evaporation in microwave cooking so foods can be cooked in the minimum water. Casseroles need about half the usual amount of stock; vegetables need only two or three tablespoons of water.

Bones: Meat and poultry bones conduct heat, therefore the areas around them will cook faster than the rest of the meat. Insert a microwave meat thermometer into the thickest part of the flesh away from any bone for an accurate grading.

Cleaning and Care

1. Turn off the oven and remove the power plug from the wall socket before cleaning.
2. Keep the inside of the oven clean. When food splatters or spilled liquids adhere to oven walls, wipe with a damp cloth. Mild detergent may be used if the oven gets very dirty. Avoid the use of spray and other harsh cleaners as they may stain, streak or dull the door surface.
3. The outside surfaces should be cleaned with a damp cloth. To prevent damage to the operating parts inside the oven, water should not be allowed to seep into the ventilation openings.
4. Wipe the door and window on both sides, the door seals and adjacent parts frequently with a damp cloth to remove any spills or splatters. Do not use abrasive cleaner.
5. Do not allow the control panel to become wet. Clean with a soft, damp cloth. When cleaning the control panel, leave oven door open to prevent oven from accidentally turning on.
6. If steam accumulates inside or around the outside of the oven door, wipe with a soft cloth. This may occur when the microwave oven is operated under high humidity condition. This is normal.
7. It is occasionally necessary to remove the glass tray for cleaning. Wash the tray in warm sudsy water or in a dishwasher.
8. The roller ring and oven floor should be cleaned regularly to avoid excessive noise. Simply wipe the bottom surface of the oven with mild detergent. The roller ring may be washed in mild sudsy water or in a dishwasher. When removing the roller ring from cavity floor for cleaning, be sure to replace in the proper position.
9. Remove odors from your oven by combining a cup of water with the juice and skin of one lemon in a deep microwaveable bowl, microwave for 5 minutes. Wipe thoroughly and dry with a soft cloth.
10. When it becomes necessary to replace the oven light, please consult a dealer to have it replaced.

Troubleshooting

Questions and Answers:

Q. Accidentally ran microwave oven without any food in it. Is it damaged?

A. We do not recommend operating the microwave oven without any food, however, running the oven empty for a short time will not damage the oven.

Q. What if oven does not turn on?

A. Check the following:
 1) Is the oven plugged in securely? Remove plug from the outlet, wait 10 seconds and reinsert.
 2) Check circuit breaker or fuse. Reset circuit breaker or replace fuse if it is tripped or blown.

Q. Can the oven be used with the glass tray removed?

A. No. The glass tray must be positioned correctly in the oven before cooking.

Q. Why does warm air come from the oven vents and steam accumulates on the oven door?

A. This is due to heat being given off from food cooking in the oven cavity. The warm air is carried out of the oven by the airflow pattern in the oven. There are no microwaves in the air. The oven vents should never be blocked during cooking. During cooking time, steam is given off from the food. Most of the steam is removed from the oven by the air, which circulates in the oven cavity. However, some steam will condense on cooler surfaces such as the oven door. This is normal.

Q. My microwave causes interference on my TV. Is this normal?

A. Some radio and TV interference might occur when you cook with the microwave oven. This interference is similar to the interference caused by small appliances such as mixers, vacuums, blow dryers, etc. It does not indicate a problem with your oven.

Q. Can TV dinner trays be placed in the oven?

A. Only TV dinners labeled microwave safe are recommended for this oven. Make sure foil covers are removed from top of container.

FELIX STORCH, INC.

770 GARRISON AVENUE BRONX, NY 10474

SUMMIT LIMITED WARRANTY

Summit Appliances warrants this product to be free from defects in materials and workmanship for a period of one year from the date of original purchase or delivery. Any parts determined to be defective will be replaced by SUMMIT at no charge to you. Plastic parts, liners and outer cabinets are warranted to be manufactured to commercially acceptable standards and free from defects at the time of delivery.

This limited warranty does not apply to:

1. Improper installation
2. Customer misuse, negligence or damage
3. Incorrect electrical current
4. Products with the serial number altered or removed
5. Products sold or used outside the fifty United States or the District of Columbia
6. Commercial or Industrial Users
7. Damage to this product from accidents, alterations, failure to follow instructions, fire, floods, earthquakes, war, civil disturbance or Acts of God.

SUMMIT is not liable for consequential or incidental damage.

SUMMIT APPLIANCE DIV.
 FELIX STORCH, INC.
 770 GARRISON AVENUE
 BRONX, NY 10474
 (718)328-8700

FACTORY REGISTRATION CARD THANK YOU FOR PURCHASING A QUALITY SUMMIT® APPLIANCE

Summit Model Number _____ Serial _____
 Customer's Name _____ Date of Delivery _____
 Address _____ Apt. No. _____
 City _____ State _____ Zip _____
 Dealer's Name _____ City _____ State _____
 Is this unit for: Private Home Apartment Office Other
 Reasons for selecting this unit: Dealer Recommendation
 Size Price Other _____