

FURRION

Heat Strip Installation Kit

Instruction Manual

Model:
C-FACR15SA-A02

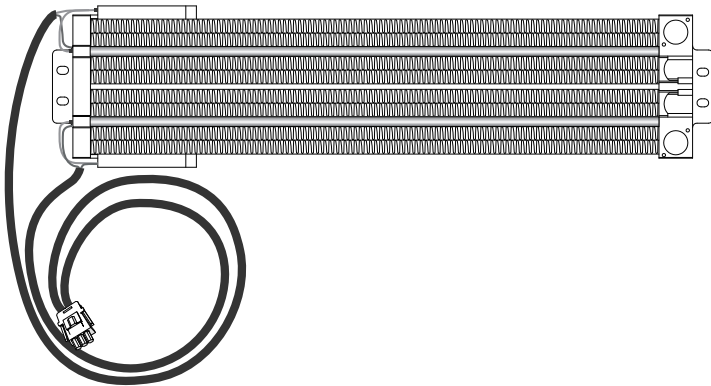

* Picture shown here is for reference only.

Thank you and congratulations for purchasing this Furrion product. Before operating your new product, please read these instructions carefully. This instruction manual contains information for safe use, installation and maintenance of the product. Please keep this instruction manual in a safe place for future reference. This will ensure safe use and reduce the risk of injury. Be sure to pass on this manual to new owners of this product. The manufacturer does not accept responsibility for any damages due to not observing these instructions.







Table of Contents

Table of Contents	1
Before Use	2
What's in the Box	2
Installation	3
Operation	6
Specifications	7

Before Use

What's in the Box

Make sure the unit and the accessories are in the box. If anything damaged or missing, contact your dealer.

Component	Description	Quantity
Model C-FACR15SA-A02		
	Heat Strip	1
	Screw ST4x9 mm	4
	Washer Ø4*Ø9*0.8mm	4
	"HEAT" Icon Sticker	1
	Connecting Harness	1
	Installation Instructions	1
	Warranty Leaflet	1

NOTE: This heat strip installation kit applies to the following models of the rooftop unit and air distribution box (ADB). Please refer to the model of your unit before installation.

- **Rooftop Unit models:** FACR13SA-PS, FACR13SA-BL, FACR14SA-PS, FACR14SA-BL, FACR15SA-PS, FACR15SA-BL.
- **Air Distribution Box models:** FACT11MA-PS, FACT11MA-BL, FACT11CA-PS.

Installation

⚠ DANGER



Electric Shock Hazard

- Disconnect power or shut off the air conditioner circuit breaker before installation.
- Failure to do so can result in electric shock.

⚠ WARNING

Installation of the heat strip must be carried out by a professional/certificated technician only.

Disassemble the Top Unit

1. Remove the 10 screws used to fix the top cover, 4 on the front, 2 on each side of air vents, and 2 on the filter grill. (Fig. 1)

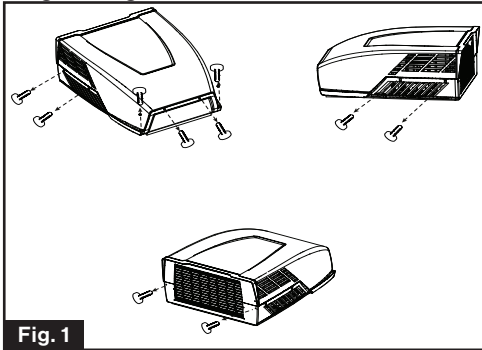

Fig. 1

2. Remove the top cover and place it on a flat surface. (Fig. 2)

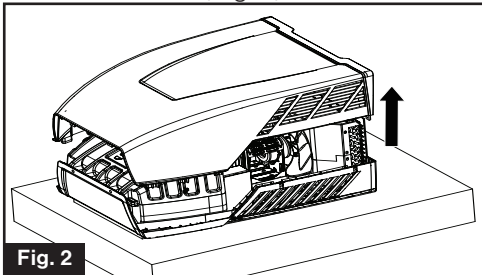

Fig. 2

3. Remove the EPP top cover of the evaporator by pulling upwards, and place it on a flat surface. (Fig. 3)

NOTE: The silicon sealant may retain the cover, gently work the shroud apart from the sealant to remove.

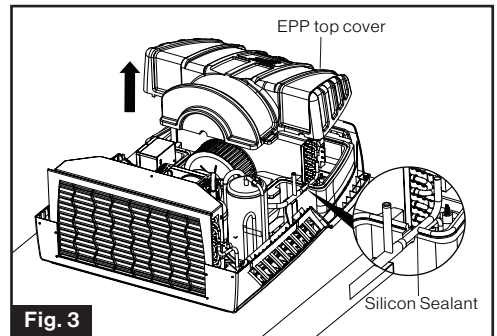

Fig. 3

Disassemble the Trim Kit

NOTE: The following steps are only for retrofitting. If installing a new system, skip to "Install the Heat Strip" section.

4. Remove the two control knobs by pulling downwards (Fig. 4).
5. Take off the decoration plate from the trim kit by pushing the side tabs to release (Fig. 4).

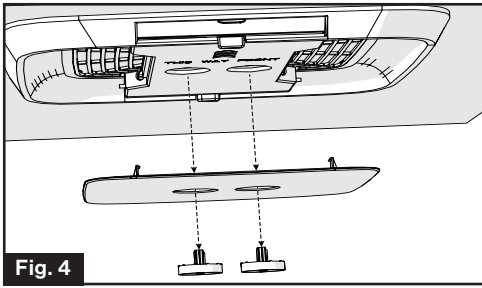

Fig. 4

6. Remove the two filters by pulling the tabs to release. (Fig. 5)

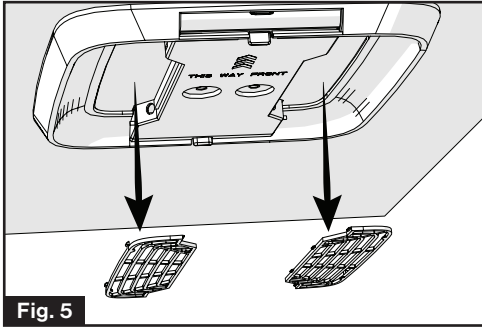

Fig. 5

7. Remove the trim kit body by unscrewing the four screws. Leave the metal bracket and mounting screws attached. (Fig. 6)

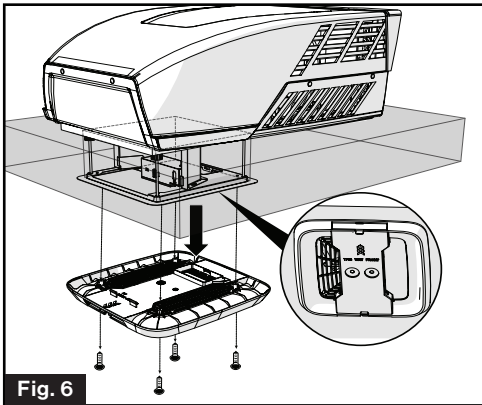

Fig. 6

Install the Heat Strip

8. Align the 4 screw holes on the heat strip with that on the evaporator, 2

holes on each side. (Fig. 7)

9. Insert four screws with washers into these holes. And then fasten them. (Fig. 7)

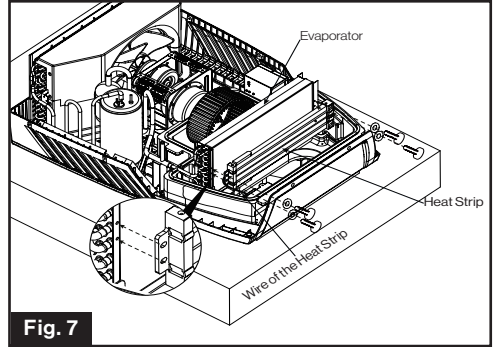

Fig. 7

NOTE: Use ST4 x 9mm screws (provided) only. Use of other type of screws may pierce/damage the copper tubing in the evaporator.

10. Fix the harnesses together with nylon cable ties (not provided). Then pass the 2 harnesses down through the air intake vent to the RV (Fig. 8).

NOTE: Retain wire harnesses away from the electric heater element and evaporator to prevent being damaged.

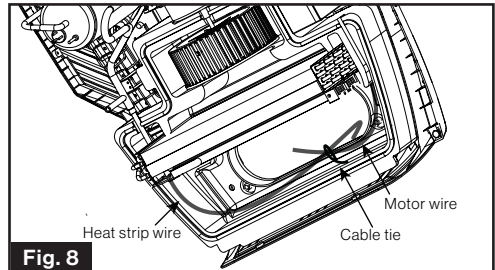

Fig. 8

11. Install the EPP top cover of the evaporator back, and ensure the pipe outlet is sealed well with the existing silicon sealant.

NOTE: Make sure the top cover is aligned with the lower cover of the evaporator when installing back.

12. Install the top cover of the rooftop unit back and fasten the 10 screws removed in step 1.

Wire Connection

⚠ DANGER

Electrical Shock Hazard

- Disconnect power before servicing.
- Failure to obey this warning could result in death or serious injury.

13. Unscrew the 3 screws on the electrical control box, remove the covers and controls attached to it (Fig. 9).

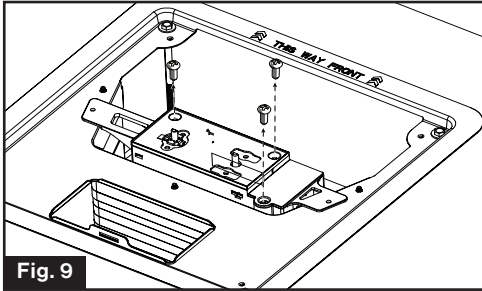

14. Plug the black wire of the connecting harness, a 3-pin terminal interface (provided), into the “H” pin of the switch. (Fig. 10)

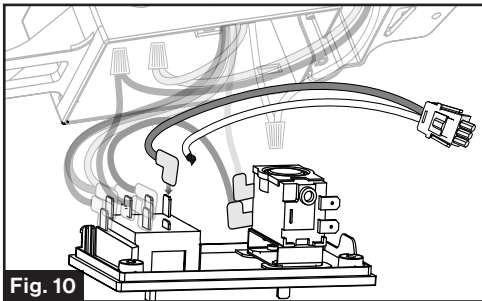

15. Route neutral/white wire over to the junction box, and connect with the other neutral/white wires. (Fig 11)

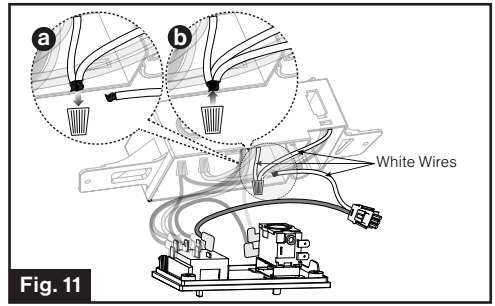

16. Install and lock the 3-pin terminal interface onto the reserved opening on the electrical control box. (Fig. 12)

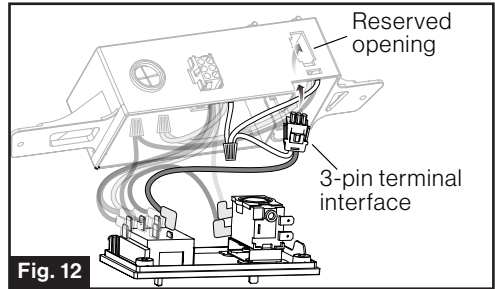

17. Put all wires in the control box and then install the box covers back and tighten the 3 screws. (Fig. 13)

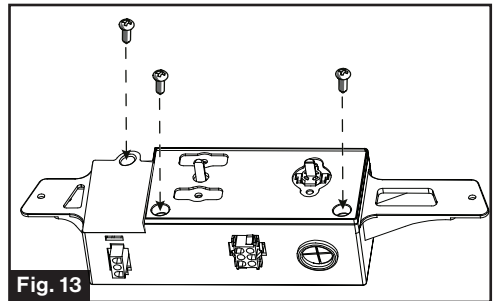

18. Plug the 3-pin connector of the heat strip into the 3-pin terminal interface on the control box. (Fig. 14)

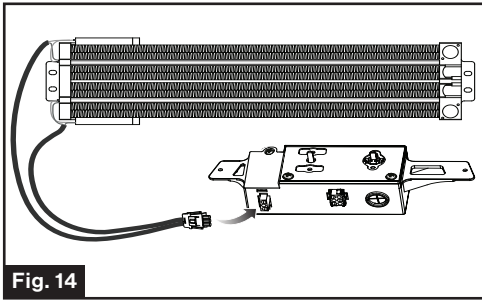

Fig. 14

19. When the heat strip is connected to the control box, reverse above steps to install the electrical box, refer to your trim kit for final installation of your AC, or reverse the steps taken to disassemble your trim kit body.
20. For the decoration plate with icon "FAN", cover with the provided "HEAT" decal. (Fig. 15)

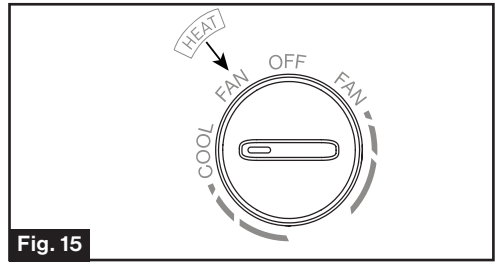

Fig. 15

For those already with silk screen HEAT(OPTIONAL), omit this step. (Fig.16)

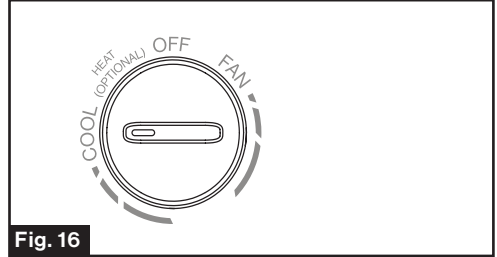
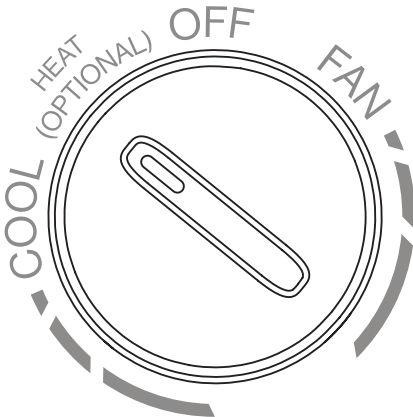

Fig. 16

Now the installation is completed.

Operation

Installation of the Heat strip has created a new "HEAT" mode with your controller. The following will describe how to operate. Operation of "FAN", "COOL" mode and "OFF" does not change, refer to your air conditioner manual for operation.



When to use HEAT mode?

During conditions where the ambient temperature has dropped between 50-70 °F, the "HEAT" mode can be utilized to bring the temperature up to a comfortable level.

The Electric Heater works best in smaller spaces, like bedrooms or isolated rooms.

NOTE: HEAT mode should not be considered a replacement to your standard furnace, or expected to heat the entire coach. It may need to be used in conjunction with the furnace under extreme conditions.

How to use it?

To activate, rotate your mode function selector to the HEAT position.

How does it work?

When you want to warm the coach, turn on the HEAT mode. Once the temperature has reached a desired condition, Manually turn the mode function selector to another mode or "OFF" position.

Manually cycle "ON/OFF" to maintain a temperature as desired.

NOTE: The temperature selector function is not usable with HEAT mode, therefore the control needs to be cycled manually to maintain temperature. Avoid excessively long usage periods to prevent overheating. Consider using the furnace to bring the temperature up first, then maintain with the HEAT mode.

Specifications

Model	C-FACR15SA-A02
Heating Capacity	1,500W
Operation Ambient Temperature	19°F-86°F (-7°C-30°C)
Volts/Hertz	115V/60Hz
Power Watts	1,500W
Power Cord Gauge	AWG14 (1.6 mm ²)
Dimensions	L 17 ¹³ / ₁₆ " x W 3 ⁷ / ₈ " x H 1 ⁵ / ₁₆ " (L 452mm x W 98mm x H 23.5mm)
Weight	0.74kg (1.63lbs)
Safety Standard	CSA/UL 60335-1, Second Edition & CSA/UL 60335-2-40, Second Edition



Furrion Innovation Center & Institute of Technology

• 52567 Independence Ct., Elkhart, IN 46514, USA • Toll free:1-800-789-3341

• Email: support@furrion.com

©2007-2020 Furrion Ltd. Furrion® and the Furrion logo are trademarks licensed for use by Furrion Ltd. and registered in the U.S. and other countries.