



16V 30Ah



PRODUCT (30A BMS)

MANUAL

Lithium Iron Phosphate (LiFePO₄) Battery

www.litime.com



PRODUCT OVERVIEW

16V 30AH BATTERY

Operating Voltage: 16V

Charging Voltage: $18.0 \pm 0.25V$

Recommended Charge Current: 6A (0.2C)

Max. Continuous Discharge Current: 30A

Max. Continuous Output Power: 480W

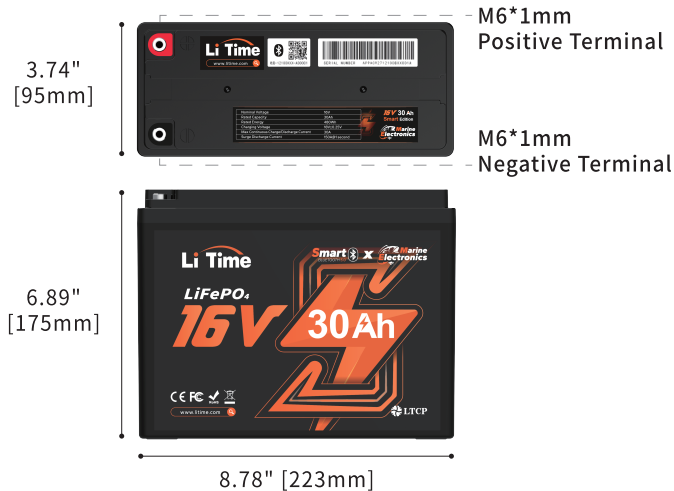

ADDITIONAL COMPONENTS

M6- 15/32" [12mm] Terminal Bolts

Recommended terminal torque: 61.96 to 79.66 inch · lbs / 7 to 9 N · m

The terminal bolts are used to secure multiple cable lugs to a single battery terminal. The bolts can be replaced with M6 bolts of other lengths based on actual needs.

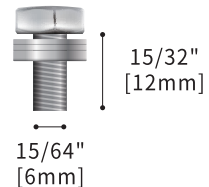

Insulating Caps for Bolts

Cover the battery with the insulating caps after tightening the bolts. If the cap melts, stop using the battery and reach out to service@litime.com for further analysis.

BATTERY PARAMETERS

Cell Type	LiFePO ₄
Nominal Voltage	16V
Rated Capacity	30Ah
Energy	480Wh
Internal Resistance	≤40mΩ
Cycle Life	≥4000 times
Battery Management System (BMS)Board	30A
Charge Method	CC/CV
Charge Voltage	18.0±0.25V
Recommended Charge Current	6A (0.2C)
Max. Continuous Charge Current	30A
Max. Continuous Discharge Current	30A
Surge Discharge Current	150A@1 second
Max. Continuous Output Power	480W

Dimension	L8.78*W3.74*H6.89 inch
	L223*W95*H175 mm
Housing Material	ABS
Recommended Terminal Torque	61.96 to 79.66 inch·lbs / 7 to 9 N·m
Protection Class	IP65
Temperature Range	Charge: 0°C to 50°C / 32°F to 122°F
	Discharge: -20°C to 60°C / -4°F to 140°F
	Storage: -10°C to 50°C / 14°F to 122°F
Low Temperature Charging Protection (LTCP) Function ^①	Yes
Resume Charging Temperature Under LTCP	5°C/41°F (Battery Temperature)

① This product supports Low Temperature Charging Protection (LTCP), where the BMS stops battery charging when the battery temperature falls below 0°C/32°F and resumes charging when the temperature rises above 5°C/41°F.

HOW TO ESTIMATE THE BATTERY CAPACITY

STATE OF CHARGE (SOC)

The battery capacity could be roughly estimated by its [resting voltage \(not charging/discharging voltage\)](#).^①

Since the voltage of each battery is slightly different, and the voltage measurement is affected by the measuring instrument, ambient temperature, etc., [the following parameters are for reference only](#). The actual SOC of the battery is based on the discharge capacity under load.

Resting Voltage: The voltage is measured after the battery has been disconnected from the charger and loads with zero current, and left alone for 3 hours.

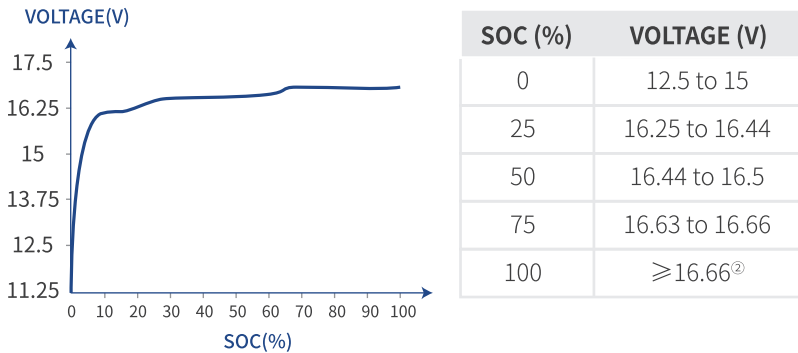

- ① Based on the characteristics of LiFePO₄ batteries, the voltage measured by all LiFePO₄ batteries during charging/discharging is not the real voltage of the battery. Therefore, after charging/discharging and disconnecting the battery from the power source, the voltage of the battery will gradually drop/increase to its real voltage.
- ② After this battery is protected from overcharge, the tested battery voltage (not the real voltage) will be lower than the real voltage. To calculate the SOC (%), add 0.5V to 0.7V to the tested battery voltage.

PARALLEL CONNECTION

THE PREMISE OF CONNECTION

To connect in parallel, batteries should meet the below conditions:

- identical batteries with the same battery capacity (Ah) and BMS (A);
- from the same brand (as lithium battery from different brands has their special BMS);
- purchased in near time (within one month).

LIMITATION FOR SERIES/PARALLEL CONNECTION

Support connecting up to 4 identical batteries in parallel for up to: 16V 120Ah battery system

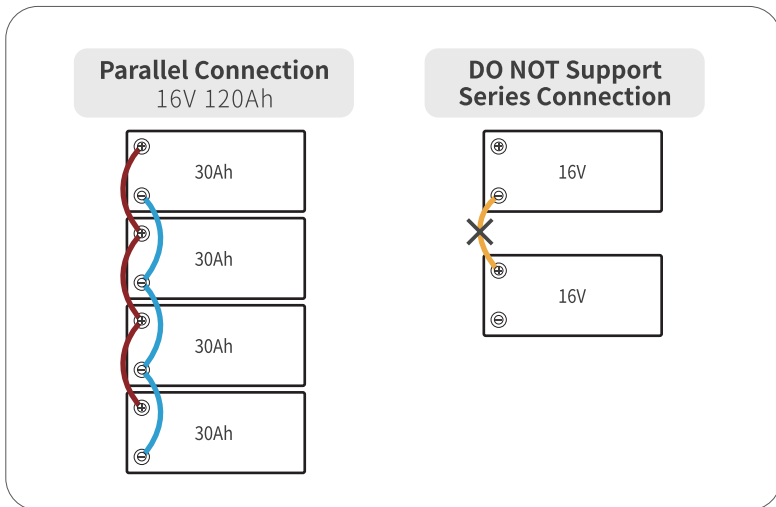

WHAT TO DO WHEN THE BATTERY STOPS WORKING?

When the battery

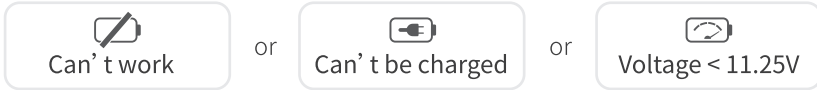

It has 85% chances that BMS has shut it off for protection, and you could try one of below ways to activate the battery.

GENERAL STEPS

If the BMS has cut off the battery for protection, follow the below steps to activate it.

Step
1

Cut off all the connections from the battery.

Step
2

Leave the battery aside for 30mins

Then the battery will automatically recover itself to normal voltage (>12.5V) and can be used after fully charged.

If the battery is unable to recover itself after the above steps, please try activating by **BELOW METHOD.**

After activated (voltage > 12.5V) and fully charged by the normal charging method, it can be used normally.

Activation Method

Use a charger with lithium battery activation function to fully charge the battery.

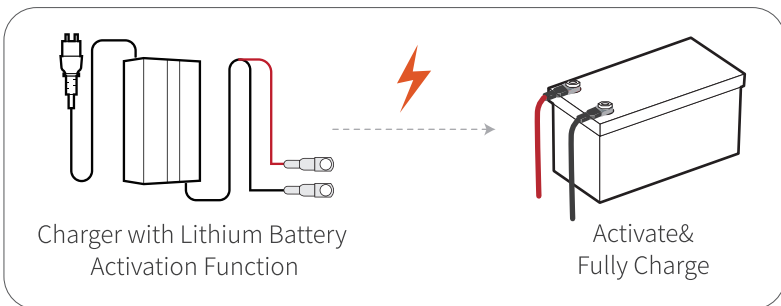

Li Time

www.litime.com



Shenzhen Litime Technology Co., Ltd