

HYUNDAI
POWER PRODUCTS

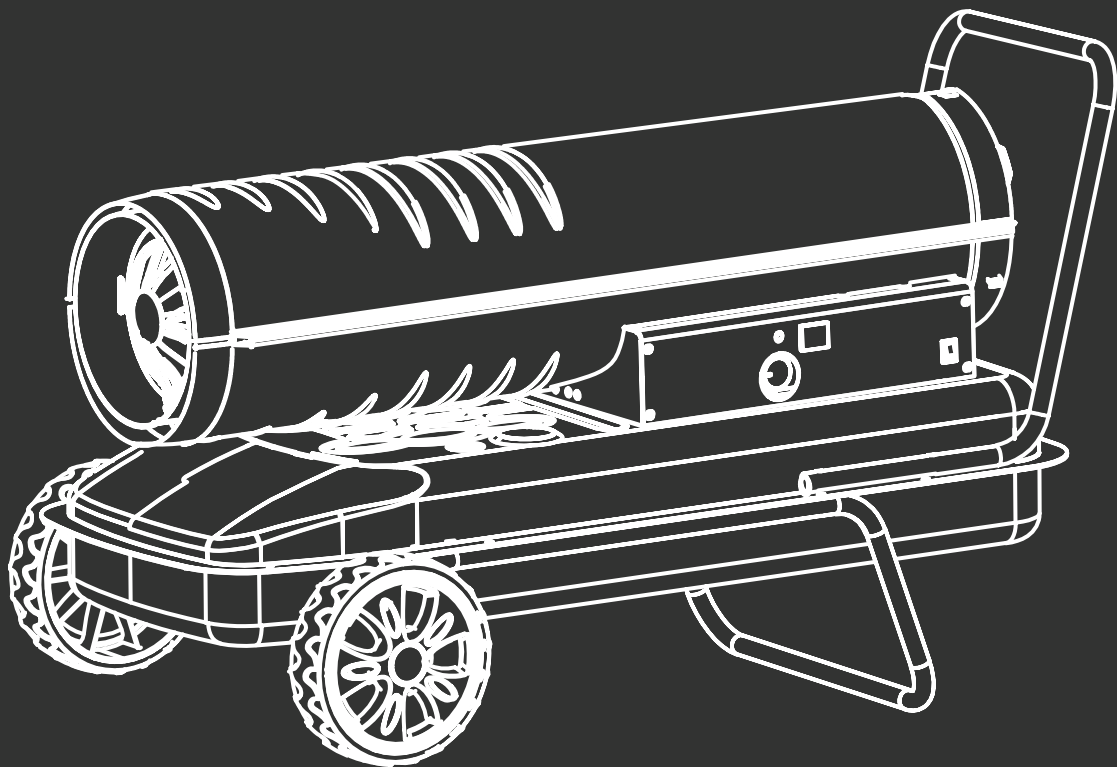

DIESEL (KEROSENE) FORCED AIR HEATER HY125DKH & HY215DKH

Instruction Manual



WARNING! Read and understand the instruction manual carefully before use.

Introduction

We work very hard to give all of our customers the best possible service. If you have any problems, before leaving negative feedback, please contact us to give us a chance to resolve the issue. We would be delighted if you left us positive feedback! Thank you for purchasing this product.

Important!



WARNING: READ THE INSTRUCTION BOOKLET THOROUGHLY BEFORE USING THE MACHINE. Keep for future reference and pass it on if the machine is loaned or sold to another user.

This manual has been produced by Hyundai Power Products and should be kept with the product. Please read and understand these instructions before you use your product. Failure to do this may result in personal injury or damage to the product.

The safety precautions and warnings are to ensure your safety and protect you from harm or damage to the product.

The information contained in this manual was accurate at the time of production, however HYUNDAI Power Products may make modifications to the product without notification.

Contents

Safety Information.....4-15

Understand Your Machine.....	4
Personal Safety.....	4-5
Inspect Your Machine.....	5
Work Area.....	6
During Use.....	6-7
Electrical Safety.....	8
Carbon Monoxide.....	9
Fuel Safety.....	10-11
Batteries.....	12
Vibrations.....	13
Noise.....	13
General Safety.....	14
Personal Protective Equipment.....	15

Unboxing.....16-17

Unboxing Safety.....	16
Box Contents.....	17

Features.....18-19

Assembly.....20

Frame & Wheel Assembly.....	20
-----------------------------	----

Operation.....21-24

Fuel.....	21
Theory Operation.....	22
Fueling The Heater.....	22
Ventilation.....	22
Starting Procedure.....	23
Stopping Procedure.....	24
Restarting Procedure.....	24

Maintenance & Care.....25-37

Checking Your Machine.....	25
Storage.....	25
Long Term Storage.....	26
Maintenance.....	27
Fuel / Fuel Tank.....	27
Air Filter.....	27
Fan Blades.....	28
Nozzles.....	29
Spark Plug.....	30
Photocell.....	31
Fuel Filter.....	32
Pump Pressure Adjustment.....	33
Fuse Replacement.....	34-35
Troubleshooting.....	36

Technical Data.....37-39

Specifications.....	37
Product Dimensions.....	38
Wiring Diagram.....	39

Recycling & Disposal.....40

Useful Information.....41

Our YouTube Channel.....	41
Warranty.....	41
Manual Updates.....	41
Returning Your Product.....	41
Leaving A Review.....	41
Ordering Spare Parts.....	41

Product Information.....42

Product Record.....	42
---------------------	----

Contact Us.....43

Safety Information

Understand Your Machine

- **WARNING!** You must read these instructions carefully before operating the machine. Make sure that you are familiar with the controls and properly operate the machine. You must learn how to stop the machine quickly. If you do not follow the warnings and instructions, it may result in fire and/or serious injury. Make sure to save all warnings and instructions for future reference.
- Read this manual and labels affixed to the machine to understand its limitations and potential hazards.
- Be thoroughly familiar with the controls and their proper operation. Know how to stop the machine and disengage the controls quickly.
- If the unit is to be used by someone other than original purchaser, or is to be loaned, rented, or sold, always provide this manual and any needed safety training before operation. The user can prevent and is responsible for accidents or injuries that may occur to themselves, to other people, or to property.
- Do not force the machine beyond its limits. Use the correct machine for your application.
- Know how to stop the machine quickly in case of emergency. Understand the use of all controls.
- ALL MAINTENANCE other than that listed in this manual, should be carried out by professionally trained and certified personnel.

Personal Safety

- **WARNING!** Never allow children or people unfamiliar with these instructions to use the product. Local regulations can restrict the minimum age of the operator.
- Keep children, pets, and other people not using the unit away from the work area. Be alert and shut off the unit if anyone enters work area. Keep children under the watchful care of a responsible adult.
- Stay alert, watch what you are doing and use common sense when operating the machine. Never operate the machine when unwell or tired, or if you have taken alcohol, medicine, drugs or any substances which may slow your reflexes and compromise judgment. A moment of inattention while operating the machine may result in serious personal injury.
- Appropriate Personal Protective Equipment (PPE), **MUST** be worn at all times when operating or repairing the machine. Always wear anti-slip and resistant work footwear and long trousers while using the machine. Do not use the machine when barefoot, wearing sandals or similar lightweight footwear. Do not wear chains, bracelets or clothing that is loose fitting or hanging ties or cords. Tie long hair back. Always wear protective earplugs. Loose clothes, jewellery, or long hair can be caught in moving parts. Protect eyes, face, and head from objects that may be thrown from the unit. Always wear safety goggles or safety glasses with side shields when operating.
- Always keep hands and feet away from all moving parts during operation. Moving parts can cut or crush body parts.
- Always keep hands and feet away from all pinch points.
- Do not touch parts that might be hot from operation. Allow parts to cool before attempting to maintain, adjust, or service.
- Do not overreach. Keep proper footing and balance at all times. This enables better control of the machine in unexpected situations. Extending your body too far can result in a loss of balance and you may fall which will result in injury.

Safety Information

- Never place any part of your body where it would be in danger if movement should occur during assembly, installation, and operation, maintenance, repairing or moving.
- Start the machine carefully according to instructions and with feet away from the moving parts.
- Do not place your hands or feet near or under rotating parts. Keep away from any discharge openings.
- Keep in mind that the operator or user is responsible for accidents, hazards or unexpected events involving the machine that occur to other people or their property. It is the responsibility of the user to assess the potential risk of the area where work is being carried out. The operator or user must take all necessary precautions to ensure their own safety and that of others, especially on slopes or rough, slippery and unstable ground.

Inspect Your Machine

- Check your machine before starting it. Keep guards in place and in working order. Make sure all nuts, bolts, etc., are securely tightened.
- You must check the general condition of the machine before use.
- Never operate the machine when it is in need of repair or is in poor mechanical condition. Replace damaged, missing, or failed parts before using it. Check for fuel leaks. Keep the machine in safe working condition.
- Do not use the machine if the switch does not turn off the machine when running. Any machine that can't be controlled with the switch is dangerous and must be replaced.
- Regularly check to see that keys and adjusting wrenches are removed from the machine area before starting it. A wrench or a key that is left attached to a rotating part of the machine may result in personal injury.
- If the machine should start to vibrate abnormally, stop the engine and check immediately for the cause. Vibration is generally a warning sign of trouble.
- Avoid accidental starting. Be sure the machine is off before transporting the machine or performing any maintenance or service on the unit. Transporting or performing maintenance or service on a machine with its switch on invites accidents.
- Do not tamper with or disable safety systems.
- Only use manufacturer-recommended attachments.
- Before using, always visually inspect to see that the tools are not worn out or damaged. Replace worn out or damaged elements and bolts in set to preserve balance.
- Keep all nuts, bolts and screws tight to ensure the equipment is in safe working condition.
- Keep the machine in good operating condition. Operating the machine in poor or questionable condition could result in serious injury.
- Be sure all safety devices are in working order and warning labels are in place. These items are installed for your safety.

Safety Information

Work Area

- Make sure you thoroughly inspect the entire work area. Any liquid spilled on the floor may result in you slipping.
- You must only work in daylight or with good artificial light in good visibility conditions. Keep people, children and animals away from the working area.
- Operate on flat, level ground.
- DO NOT work on wet ground. If there has been heavy rain on the working site, wait until the ground has dried up.
- Never park the machine in a place with unstable ground which could give way.
- You must be careful near ravines, ditches or embankments.
- Do not work in the rain or when there is a thunderstorm or lightning risk. If there is bad weather conditions, do not use the machine.

• **WARNING!** Risk on indoor air pollution!

- Use this heater only in well ventilated areas. Provide at least a three square foot (2800sq cm) opening of outside air for every 29kW/hr or heater rating.

Minimum clearance from combustibles:

Top : 125cm

Side : 125cm

Front : 125cm

During Use

- Walk, never run with the machine. Be very careful when pulling the machine toward you. You must look behind you to make sure there are no obstacles before and during operations in reverse gear (if applicable). Do not allow the machine to pull you along, you must walk and never run.
- **WARNING!** If something breaks or an accident happens whilst working, you must turn off the machine immediately and move the machine away to prevent further damage. If an accident happens with injuries or third parties are injured, carry out the first aid measures most suitable for the situation immediately and contact the medical authorities for any necessary health care. Carefully remove any debris that might cause damage or harm persons or animals should it not be seen.
- Do not carry passengers.
- Always turn off the machine and ensure that all moving parts have come to a complete stop before making any repairs, adjustments, or inspections.

Safety Information

⚠ WARNING! Risk Of Burns / Fire / Explosion

- NEVER use fuels such as gasoline, benzene paint thinners, or other oil compounds in this heater (RISK OF FIRE OR EXPLOSION).
- NEVER refill the heater's fuel tank while heater is operating or still hot. This heater is EXTREMELY HOT while operating.
- Keep all combustible materials away from this heater.
- NEVER block air inlet or air outlet of the heater.
- NEVER use duct work in front or at rear of heater.
- NEVER move or handle heater while still hot.
- NEVER transport heater with fuel in its tank.
- If equipped with a thermostat, the heater may start at any time.
- ALWAYS locate heater on a stable and level surface.
- ALWAYS keep children and animals away from the heater.
- Bulk fuel storage should be a minimum of 762cm from heaters, torches, portable generators or other sources of ignition. All fuel storage should be in accordance with federal, state, or local authorities have jurisdiction.
- NEVER use this heater in living or sleeping areas.
- NEVER use this heater where flammable vapours may be present.

Safety Information

Electrical Safety

⚠️WARNING! It is the responsibility of the owner to check this electrical product before use to ensure it is safe. You must inspect power cables, plugs, sockets, etc for signs of wear or damage. You must ensure this risk of electric shock is minimised by the installation of appropriate safety devices. A residual current circuit breaker (RCCB) should be incorporated in the main distribution board. We also recommend a residual current device is used (RCD). An RCD is particularly important for mobile devices that are connected to a supply without an RCCB. Any fault rectification or electrical work including the connection of a plug must be carried out by a qualified electrician.

You must also comply with electrical safety requirements including the Electricity at Work Act 1989 which requires portable electrical appliances used on business premises be PAT tested annually. The Health & Safety at Work Act 1974 places responsibility for safe condition of electrical appliances upon owners. Power cables and plugs should always be regularly inspected for safety. If in doubt about electrical safety, you must consult a qualified electrician.

⚠️WARNING! Risk of electric shock!

- Use only the electrical power (voltage and frequency) specified on the model plate of the heater. Use only a local correct plug, grounded outlet and extension cord.
- ALWAYS install the heater so that it is not directly exposed to water spray, rain, dripping water, or wind.
- ALWAYS unplug the heater when not in use.



DANGER!
ELECTRICITY CAN KILL - NEVER WORK ON LIVE/ENERGISED EQUIPMENT.

- Prior to carrying out any maintenance work you MUST identify electrical isolation methods and isolate all electrical supplies.
- Prior to use and with all electrical supplies isolated, you MUST check all electrical cables, plugs and connectors for the following;
 - Are intact and have no signs of damage, to include but not limited to bare wires, chaffing, cuts and loose wiring.
 - If there are any signs of damage, the damaged item MUST be taken out of service until the damage has been repaired by an electrically competent person.
 - All trailing cables should be routed so as not to cause any kind of trip hazard.
 - NEVER work on or near electricity with wet hands, wet clothing and wet gloves.

Safety Information

Carbon Monoxide

DANGER!

Carbon Monoxide is a poisonous gas and can kill in minutes. **NEVER** use inside a building or in an area with poor ventilation. **NEVER** use inside a confined space, such as but not limited to a house, garage, vehicle, boat or tent.

CARBON MONOXIDE IS A COLOURLESS, ODOURLESS GAS. INHALING THIS GAS CAN CAUSE DEATH OR SERIOUS LONG-TERM HEALTH PROBLEMS SUCH AS BRAIN DAMAGE.

Never operate in a confined space where dangerous carbon monoxide fumes can develop. All ignition operations have to be effected in an open or well-ventilated area. Always remember that exhaust fumes are toxic.

The symptoms of carbon monoxide poisoning can include but are not limited to the following; Headaches, dizziness, nausea, breathlessness, collapsing or loss of consciousness.

Carbon monoxide poisoning symptoms are similar to flu, food poisoning, viral infections and simply tiredness. It is quite common for people to mistake this very dangerous poisoning for something else.

To avoid carbon monoxide poisoning **DO NOT** use Petrol/Diesel powered equipment inside any of the following; Home, garage, tent, camper van, mobile home, caravan or boat. **DO NOT** use in an enclosed area or moving vehicle. This is not exhaustive and if you are in any doubt contact your dealer.

If you think you have or someone around you has been affected by carbon monoxide poisoning; Get them fresh air immediately, by leaving the affected area or by opening doors and windows. If safe and practical to do so make sure that the machine is turned off. **DO NOT** enter a room you suspect of having carbon monoxide present – instead call the emergency services.

Contact a Doctor immediately or go to Hospital – let them know that you suspect carbon monoxide poisoning.

Safety Information

Fuel Safety



CAUTION! ALL FUELS ARE HIGHLY FLAMMABLE AND PETROL VAPOUR IS EXPLOSIVE. TAKE EXTREME CARE WHEN HANDLING FUEL. KEEP FUEL OUT OF REACH OF CHILDREN.

General Safety

- Do not smoke each time fuel is handled.
- ALWAYS avoid inhaling fumes.
- ALWAYS carry fuel in the correct and clearly marked container.
- ALWAYS wear correct, suitable and fit for purpose Personal Protective Equipment (PPE), suggested items are but not limited to safety gloves and overalls.
- To avoid sparking or arcing, keep grounded conductive objects – such as tools – away from exposed, live electrical parts and connections. These events could ignite fumes or vapors.
- Do not operate the machine with known leaks in the fuel system.
- Fire hazard - keep fuel away from all sources of ignition for example heaters, lamps, sparks from grinding or welding.
- DO NOT carry out hot work on tanks that have contained fuel.
- ALWAYS keep the work area tidy.
- ALWAYS dispose of waste fuels correctly.
- Serious personal injury can occur when petrol is spilled on yourself or your clothes. Rinse your skin and change your clothes immediately.

Spilled Fuel

- If you have spilled fuel, make sure you do not attempt to ignite the engine but move the machine away from the area of spilled fuel and avoid creating any source of ignition until the fuel has evaporated and fuel vapours have dissipated.
- When fuel is spilled on yourself or your clothes, wash your skin and change clothes immediately.
- ALWAYS clean up spills promptly using absorbent granules and a lidded bin.

Safety Information

Fueling / De-Fueling

- ALWAYS fuel and de-fuel in a well ventilated area outside of buildings. Use a funnel to add fuel, only outdoors. Do not smoke during this and each time fuel is handled.
- Add fuel before igniting the engine, never remove the fuel tank cap or add fuel whilst the engine is running or when it is hot.
- When de-fueling ALWAYS use a proper fuel retriever.
- Never overfill the fuel tank. Engine heat can cause fuel to expand, never fill the tank to more than 1/2" below the bottom of the filler neck. This will provide space for fuel expansion.
- When refilling or draining the fuel tank, use an approved fuel storage container while in a clean, well-ventilated outdoor area. While adding fuel or operating the unit, do not smoke, and stay away from sparks, open flames, or other sources of ignition near the area of operation.
- Always stop the engine and allow it to cool before filling the fuel tank. Never remove the cap of the fuel tank or add fuel while the engine is running or when the engine is hot.
- Loosen the fuel tank cap slowly to relieve any pressure in the tank.
- ALWAYS keep the handles dry, clean and free of oil and fuel.
- After fueling, ensure to tighten the cap securely.
- Never use the lock-function when filling with fuel.

Storage

- Store fuel in containers specifically designed and approved for fuel storage.
- Store fuel in a cool, well-ventilated area, safely away from sparks, open flames, or other sources of ignition.
- Never store fuel – or a machine with fuel in the tank – inside a building where fumes may reach a spark, open flame, or any other source of ignition (such as a water heater, furnace, or clothes dryer). Allow the engine to cool before storing in any enclosure.
- Replace all fuel tank and container caps securely and wipe up spilled fuel. Never operate the unit without the fuel cap securely in place.

Safety Information

Batteries (Where Present)

Batteries present a risk if they become damaged by the possible leaking of electrolyte. This electrolyte is an acid and can cause serious burn injuries. Care should be taken when working on or near them. **NOTE** the electrolyte may be in a liquid or gel form.

Should you come in to contact with electrolyte you should;

- Remove all clothing contaminated with electrolyte. If you cannot remove then saturate them in water.
- Get medical assistance as soon as possible.

You must advise the medical staff of the type of acid.

- Lead/acid battery = dilute sulphuric acid.
- Nickel/cadmium = potassium hydroxide alkali electrolyte.
- Use fresh running water to wash off excess electrolyte, continue this until medical assistance arrives. Make sure that you do not wash the electrolyte to another part of your body or face.
- If electrolyte comes in to contact with Eyes the electrolyte needs to be immediately washed away with large amounts of water. Make sure that you do not wash the electrolyte to another part of your face or body.
- Gasses from charging batteries are highly flammable and great care should be taken to charge in well ventilated areas.
-  There is an explosion risk if the battery terminals are short circuited, when connecting/disconnecting ALWAYS exercise great care so that the terminals or battery leads are NOT allowed to touch and cause a spark. ALWAYS use suitable insulated tools.

Safety Information

Vibrations (Where Applicable)

- Prolonged use of hand held (operated) machines will cause the user to feel the effects of/from vibrations. These vibrations can lead to white finger (Raynaud's phenomenon) or carpal tunnel syndrome. This condition reduces the ability of the hand to feel and regulate temperature, causing numbness and heat sensations and may cause nerve damage and circulatory tissue death.
- Not all factors that lead to white finger disease are known, but cold weather, smoking and other diseases that affect blood vessels and blood circulation as well as large and long-lasting impact of shocks are considered factors in the formation of white finger. Note the following to reduce the risk of white finger and carpal tunnel syndrome;
- Wear gloves and keep your hands warm.
- Take regular breaks.
- All of the above precautions may help reduce the risk of white finger disease but not rule out the carpal tunnel syndrome. Long-term and regular users are therefore recommended to observe the condition of your hands and fingers. Seek medical attention immediately if any of the above symptoms should occur.

Noise (Where Applicable)

- The operating noise of the machine can damage your hearing. When wearing protection such as earplugs or ear defenders to protect your hearing. Long-term and regular users are advised to have hearing checked regularly. Be especially vigilant and cautious when wearing ear protection because your ability to hear alarm warnings will be reduced.
- Noise emissions for this equipment is unavoidable. Carry out noisy work at approved times and for certain periods. Limit the working time to a minimum. For your personal protection and protection of people working nearby it is also advisable for them to wear hearing protection.



- See Certificate of Conformity section for Outdoor Noise declaration of conformity.

Safety Information

General Safety

⚠IMPORTANT! Read and understand all of the directions in this manual before assembling, starting, or servicing the heater. Improper use of this heater can cause serious injury. Keep manual for future reference.

⚠DANGER! NOT FOR USE IN NON-ADEQUATELY VENTILATED ENCLOSED AREAS.

⚠WARNING! Fire, burn, inhalation and explosion hazard. Keep combustibles, such as building materials, paper or cardboard, a safe distance away from the heater as recommended by these instructions. Never use the heater in spaces which contain products such as gasoline, solvents, paint thinners, dust particles, volatile or airborne combustibles, or any unknown chemicals. This is an unvented portable heater. It uses air (oxygen) from the area in which it is used. Adequate combustion and ventilation air must be provided. Refer to VENTILATION.

⚠WARNING! Do not operate this heater until you have read, and thoroughly understand these safety and operating instructions. Failure to comply with the precautions and instructions provided with this heater can result in death, serious bodily injury, property loss or damage from the hazards of fire, soot production, explosion, burns, asphyxiation or carbon monoxide poisoning. Only persons who can read and understand these instructions should use or service this heater. Not for use in home or recreational vehicles.

- This product is not suitable for use on wood floors or other combustible materials.

This is a Diesel (1-K Kerosene) directed-fire forced air heater. It is primarily intended for use for temporary heating of buildings under construction, alteration or repair. Directed-fired means that all of the combustion products of the heater enter the heated space. This appliance is rated at 98% combustion efficiency, but does produce small amounts of Carbon Monoxide. Carbon Monoxide is toxic.

For optimal performance of this heater, it is strongly suggested that 1-K Kerosene is used, 1-K Kerosene has been refined to virtually eliminate contaminants, such as sulfur. Which can cause a rotten egg odour during the operation of the heater. However, #1 or #2 fuel oil-diesel may also be used if 1-K Kerosene is not available. Be advised that these fuels do not burn as clean as 1-K Kerosene, and care should be taken to provide more fresh air ventilation to accommodate any added contaminants that may be added to the heated space. Use of #1 or #2 fuel oil may result in more periodic maintenance.

Safety Information

Personal Protective Equipment

Appropriate Personal Protective Equipment (PPE), **MUST** be worn at all times when operating or repairing the machine. No protective equipment can ensure 100% protection.

When selecting PPE, make sure it's CE marked and it suits the user in terms of size, fit, etc. If more than one item of PPE is worn at the same time, make sure they can be used together, e.g. wearing safety glasses may disturb the seal of a respirator, causing air leaks.



HAND PROTECTION MUST BE WORN

Protective electrically non-conductive gloves are highly recommended when working.



FOOT PROTECTION MUST BE WORN

Non-skid heavy duty footwear are highly recommended when working.



HEARING PROTECTION MUST BE WORN

Suitable safety hearing protection is recommended.



EYE PROTECTION MUST BE WORN

Always wear safety glasses/goggles and/or face shields. Everyday eyeglasses have only impact resistant lenses; they are not safety glasses/goggles.



PROTECTIVE CLOTHING MUST BE WORN

Do not wear loose clothing, gloves, scarfs, neckties or jewellery (rings, wrist watches), which can be caught in moving parts.



HEAD PROTECTION MUST BE WORN

Wear a safety helmet with a safety visor.



FACE SHIELD MUST BE WORN

Wear a face shield to protect your face.



RESPIRATOR MUST BE WORN

Wear a respirator.

Unboxing

Unboxing Safety

▲WARNING! Unboxing and assembling the machine should be done on a flat, stable surface with enough room. Disposal of the packaging should be done in accordance with the local regulations in force.

▲WARNING! Some of the packaging material may be harmful to children. Keep out of reach of children.

Carefully remove the product from the packaging and examine it for any sign of damage caused during shipping. Lay the contents out and check them. If any part is damaged or missing, you must not use the machine. Contact HYUNDAI Power Products immediately. You must keep the packaging material in case the machine needs to be returned or repaired.

Ensure that you have all the accessories and tools you need for assembly and operation including the suitable personal protective equipment.

Unboxing

Box Contents

- A** User Manual
- B** 2 x Wheels
- C** 2 x Wheel Caps
- D** Frame Component Hardware (6 Screws & 6 Nuts)
- E** 2 x Washers
- F** 2 x Cotter Pins
- G** Axle
- H** Wheel Support Frame
- I** Rear Handle

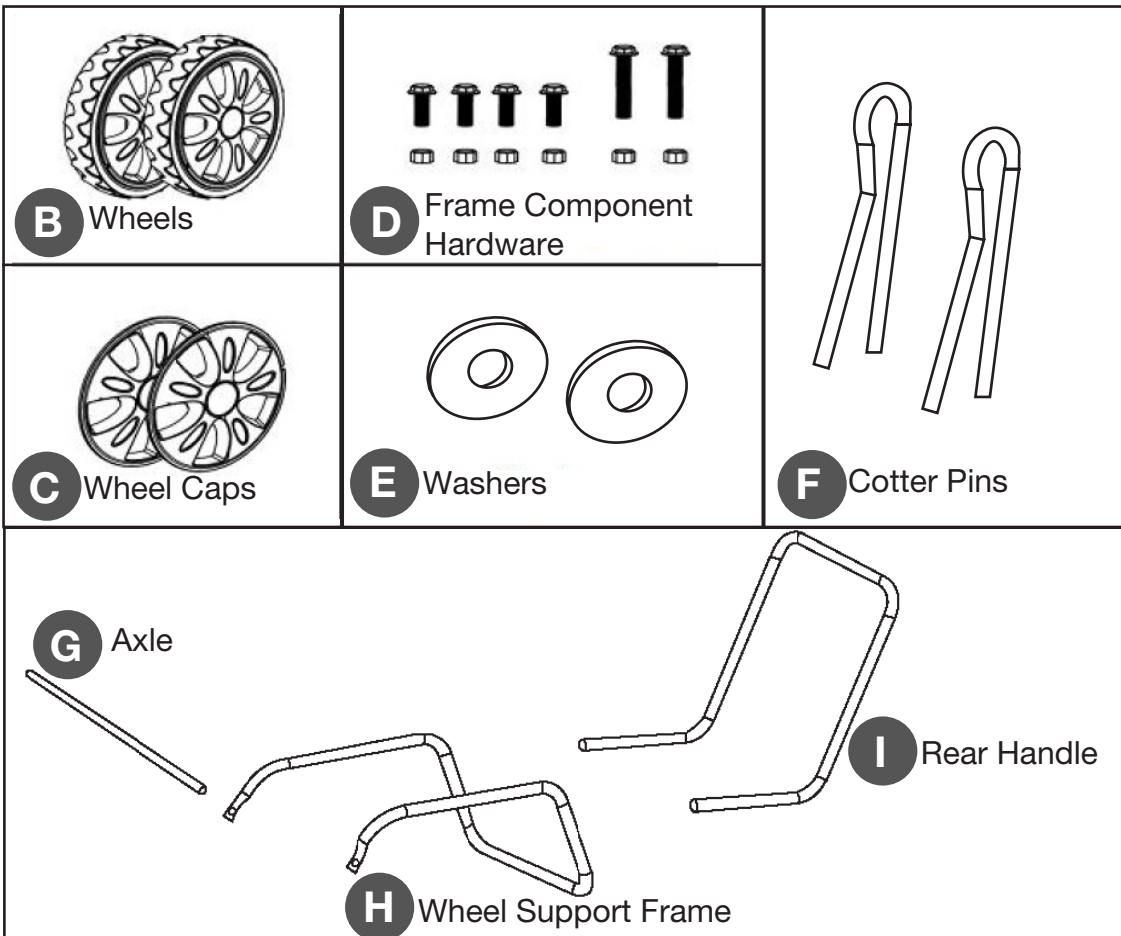

Features

HY125DKH & HY215DKH Features

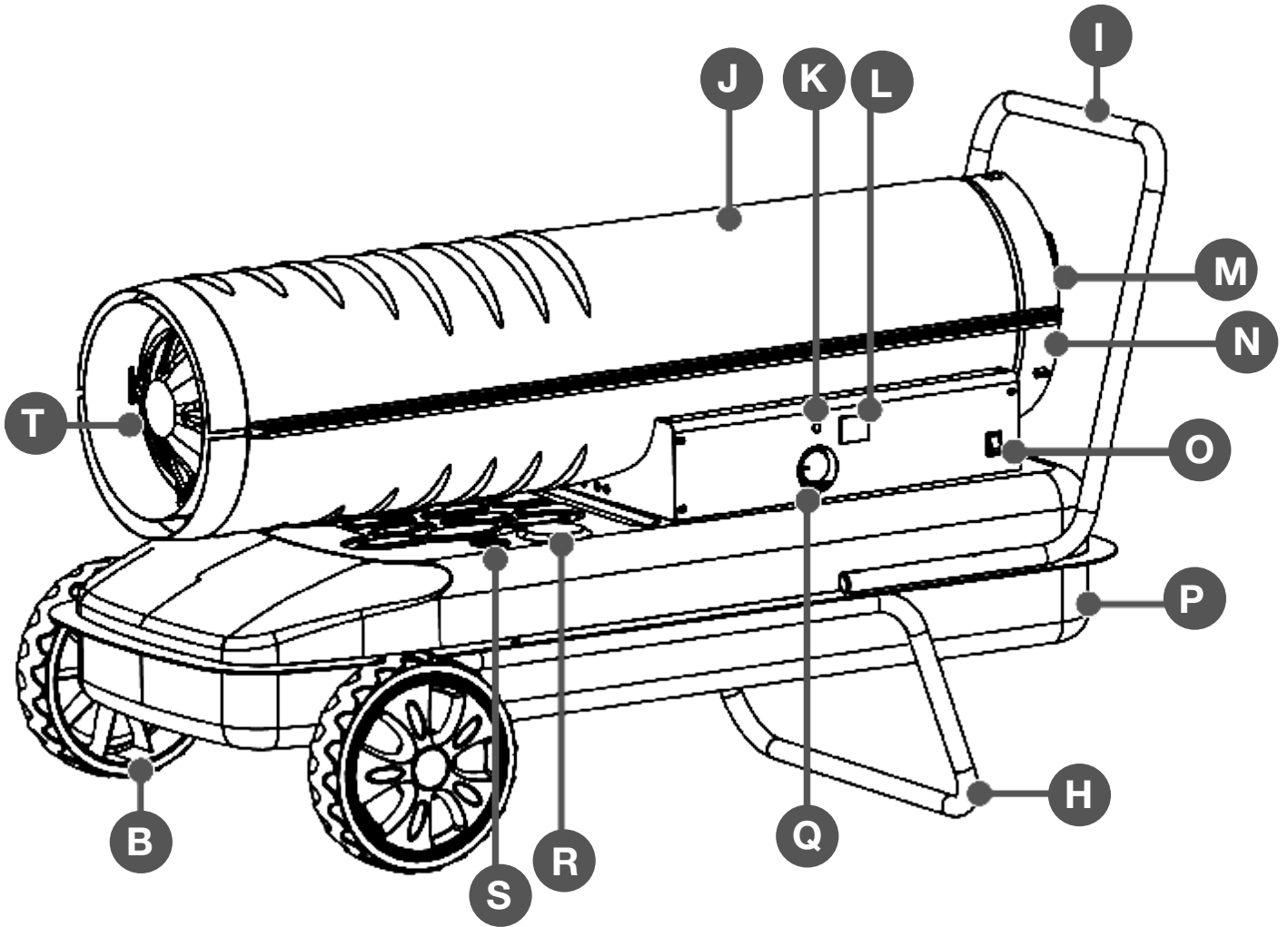

Features

HY125DKH & HY215DKH Features

- B** Wheel
- H** Wheel Support Frame
- I** Rear Handle
- J** Upper Shell
- K** Lamp
- L** Digital Temperature Display
- M** Fan Guard
- N** Lower Shell
- O** Power / Reset Switch
- P** Fuel Tank
- Q** Thermostat Knob
- R** Fuel Cap
- S** Fuel Gauge

Assembly

Frame & Wheel Assembly

Tools required : Medium Philips screwdriver, 5/16" open end or adjustable wrench and needle nose pliers.

1. Slide axle through holes in wheel support frame.
2. Slide wheels onto each axle, being sure that the valve stem (if pneumatic) is to the outside.
3. Slide flat washers (L) onto axle past the small hole. Insert cotter pin in axle hole and bent legs of pin with needle nose pliers to secure.
4. Place heater on the assembled frame, making sure that the air inlet end is by the wheels, and the mounting holes on the tank flange of the heater align with holes in frame.
5. Take the rear handle and align the mounting holes with the corresponding holes in the tank flange/wheel frame, slide a screw through the holes and loosely attach a nut. Repeat for the other 2 holes, then fully tighten all 6 screws and nuts.

⚠ CAUTION!

Do not operate heater without support frame fully assembled to tank.

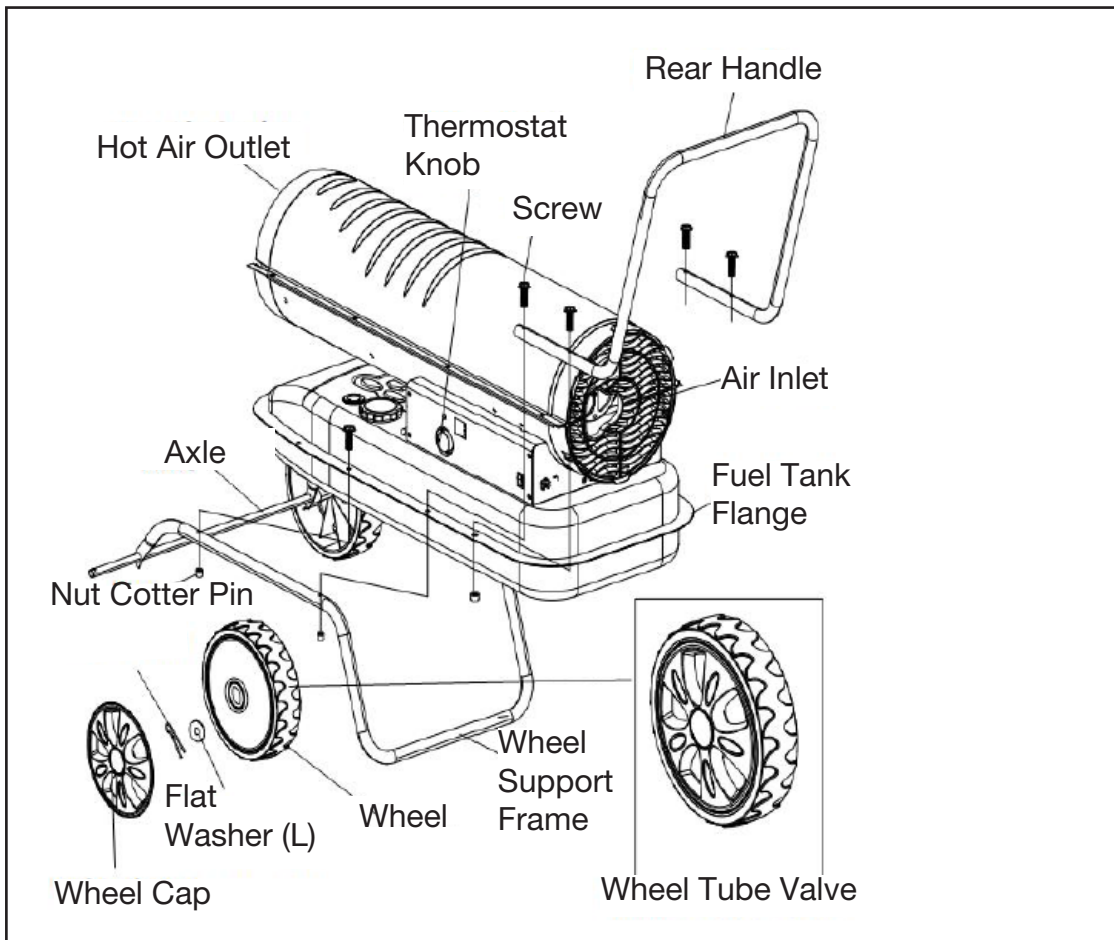

Operation

Fuel

For optimal performance of this heater, it is strongly suggested that 1-K kerosene be used, 1-K kerosene has been refined to virtually eliminate contaminants, such as sulfur. Which can cause a rotten egg odour during the operation of the heater. However, #1 or #2 fuel oil - Diesel may also be used if 1-K kerosene is not available. Be advised that these fuels do not burn as clean as 1-K kerosene, and care should be taken to provide more fresh air ventilation to accommodate any added contaminants that may be added to the heated space. Use diesel fuel can cause excess soot production.

DO NOT use any fuel that is not approved above.

NOTE: Diesel (1-K kerosene) should only be stored in a blue container that is clearly marked "Diesel (1-K kerosene)". Never store diesel (1-K kerosene) in a red container. Red is associated with gasoline.

- NEVER store diesel (1-K kerosene) in the living space. Diesel (1-K kerosene) should be stored in a well ventilated area outside the living area.**
- **NEVER use fuel such as gasoline, benzene, alcohol, white gas, camp stove fuel, paint thinners, or other oil compounds in this heater (THESE ARE VOLATILE FUELS THAT CAN CAUSE A FIRE EXPLOSION).**
- **NEVER store diesel (1-K kerosene) in direct sunlight or near a source of heat.**
- **NEVER use Diesel (1-K kerosene) that has been stored from one season to the next. It deteriorates over time. OLD DIESEL (1-K kerosene) WILL NOT BURN PROPERLY IN THIS HEATER.**
- **Use diesel in the heater/ 1-K kerosene is a suitable substitute.**

Operation

Theory Operation

Fuel System

This heater is equipped with an air pump that operates off of the electric motor. The pump forces air through the air line connected to the fuel tank, drawing fuel to the nozzle in the burner head. Air also passes through the nozzle where it mixes with the fuel and is sprayed into the combustion chamber in a fine mist.

Quick-Fire Ignition

A transformer sends high voltage to a two pronged spark plug. The spark ignites the fuel/air mixture as it is sprayed into the combustion chamber.

Air System

A fan is turned by the heavy duty motor, which forces air around and into the combustion chamber, where it is super-heated and forced out the front of the chamber.

Temperature Limit Control

This heater is equipped with a temperature limit control designed to turn the heater off should the internal temperature rise to an unsafe level, if this device activates and turns your heater off, it may require service. Once the temperature falls below the reset temperature, you will be able to start your heater.

Electrical System Protection

The heater's electrical system is protected by a circuit breaker that protects the system components from damage. If the heater fails, check the fuse first, and replace if necessary.

Flame Sensor

The heater uses a photocell to see the flame in the combustion chamber. Should the flame extinguish, the sensor will stop electrical current and the heater will shut off.

Fuelling The Heater

⚠CAUTION! NEVER FILL FUEL TANK INDOORS. ALWAYS FILL FUEL TANK OUTDOORS. BE SURE THAT THE HEATER IS ON LEVEL GROUND WHEN FUELLING, AND NEVER OVERFILL FUEL TANK.

⚠WARNING! NEVER REFUEL THIS HEATER WHILE IT IS HOT OR OPERATING, FIRE OR EXPLOSION COULD RESULT.

It is always a good idea to fire the heater outdoors for the first time. This will allow any oils used in the manufacturing process to be burned off in a safe environment. This initial burn should last at least 10 minutes.

Ventilation

Risk of indoor air pollution. Use heater only in well ventilated areas.

Always provide a fresh air opening in the heated space of at least three square feet (2800sq.cm) for each 29kW/hr of heater output. Provide a larger opening if more heater will require.

- a two-car garage door raised 15.24cm (6 inches)
- a single-car garage door raised 15.24cm (9 inches)
- TWO, a 76cm (30 inches) windows raised 38.1cm (15 inches)

Operation

Starting Procedure

1. Fill the tank with diesel (1-K kerosene) until fuel gauge point to "F".
2. Be sure fuel cap is secure.
3. Plug power cord into the local correct plug. Grounded extension cord and plug extension cord into three prong 220-240V grounded outlet. The extension cord should be at least six feet (1.8 metres) long.
 - Extension cord wire size requirements are as follows:
 - 6 to 10 feet (1.8 to 3 metres), use AWG wire.
 - 11 to 100 feet (3.4 to 30.4 metres), use 16 AWG wire.
 - 101 to 200 feet (30.8 to 61 metres), use 14 AWG wire.
4. Turn thermostat control knob to desired temperature setting. The setting range is from 40°F to 110°F. Push the power switch to the room temperature display will light and the heater will start.

NOTE: The room temperature display will indicate the following:

- When room temperature is less than 0°F, display will show "LO". If the heater does not fire, the thermostat maybe set too low. Turn the control knob to a higher setting until heater fires, if the heater still does not start, push power switch to "OFF", then back to "ON". If heater still does not fire, see troubleshooting guide.

NOTE: The electrical components of this heater are protected by a fuse mounted in the PC board, if the heater fails to fire, check the fuse first, and replace if necessary. Also check the power source to be sure that the proper voltage is being provided to the heater.



Operation

Stopping Procedure

Simply turn the power switch to “OFF” position and unplug the power cord.

Restarting Procedure

1. Wait 10 seconds after shutting off the heater.
2. Turn the power switch to “ON” position.
3. Be sure to follow all starting procedure precautions.

Maintenance & Care

Checking Your Machine

When checking your machine, we recommend you:

- Check for worn or damaged parts
- Make sure all nuts, screws and bolts are tight
- Make sure all warning stickers are in place and not damaged

 If there are worn or damaged parts, never use the machine. Faulty or worn-out parts must be replaced and not repaired. You must only use original spare parts. The use of non-original and/or incorrectly fitted parts will jeopardize the safety of the machine. This may also cause accidents or personal injuries for which the manufacturer is under no circumstance liable or responsible.

 Be very careful during adjustment of the machine to prevent entrapment of the fingers between moving parts and fixed parts of the machine.

Storage

 Store in a cool, dry, well-ventilated place away from sources of ignition and varying changes in temperature.

 Store on a flat and level surface.

 DO NOT stack other items on top of the machine when in storage.

 Store the machine in a safe place, out of the reach of children or anyone who is not familiar with operation.

 Be sure that the storage area is free of dust and corrosive vapours. Repack the heater in the original shipping material. Keep the users manual in an easily accessible place.

Maintenance & Care

Long Term Storage

Drain Fuel Tank

1. Drain fuel through the drain plug at the bottom of the fuel tank.
2. To remove the drain plug, pull the plug grip downward and remove seal head from drain hole tank.
3. Using a small amount of diesel (1-K kerosene), rinse and swirl the diesel (1-K kerosene) inside of the fuel tank, empty the tank fully.
4. To replace, push the drain head fully into the drain hole and secure by pushing the seal cap fully into the head hole.

IMPORTANT : Never store leftover Diesel (1-K kerosene) over the summer. Using old fuel can damage your heater.

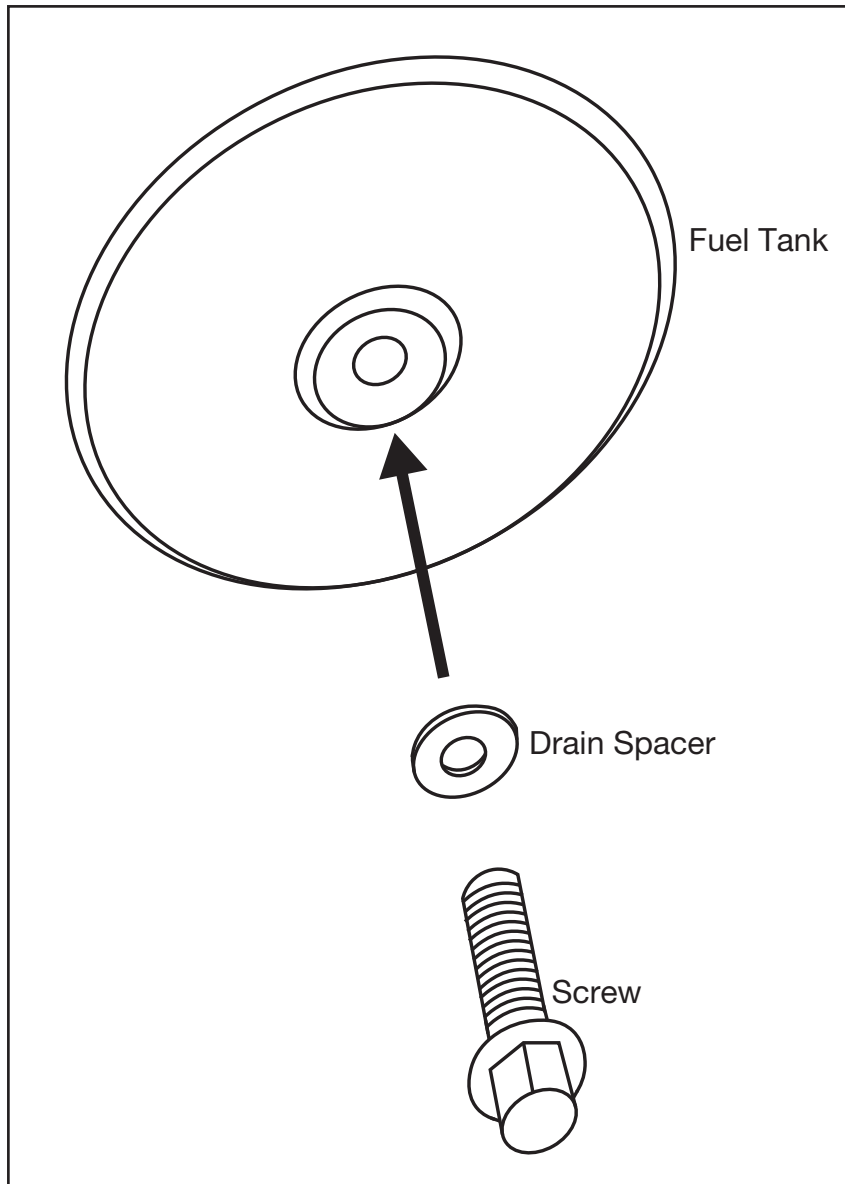

Maintenance & Care

Maintenance

⚠WARNING! Never service heater while it is plugged in or while hot!

Use only original equipment replacement parts. The use of alternate or third party components can cause unsafe operating conditions, and will void your warranty.

We suggest following a maintenance schedule as follows:

Fuel / Fuel Tank

Flush every 200 hours of operation or as needed. Do not use water to flush the tank, use fresh diesel (1-K kerosene) only.

Air Filter

The air filter should be replaced or washed with soap and water and dried thoroughly every 500 hours of operation, or less, depending on conditions.

The output and lint filter should be replaced every 500 hours of operation, or less, depending on conditions.

NOTE: Use of diesel (1-K kerosene) may require additional maintenance.

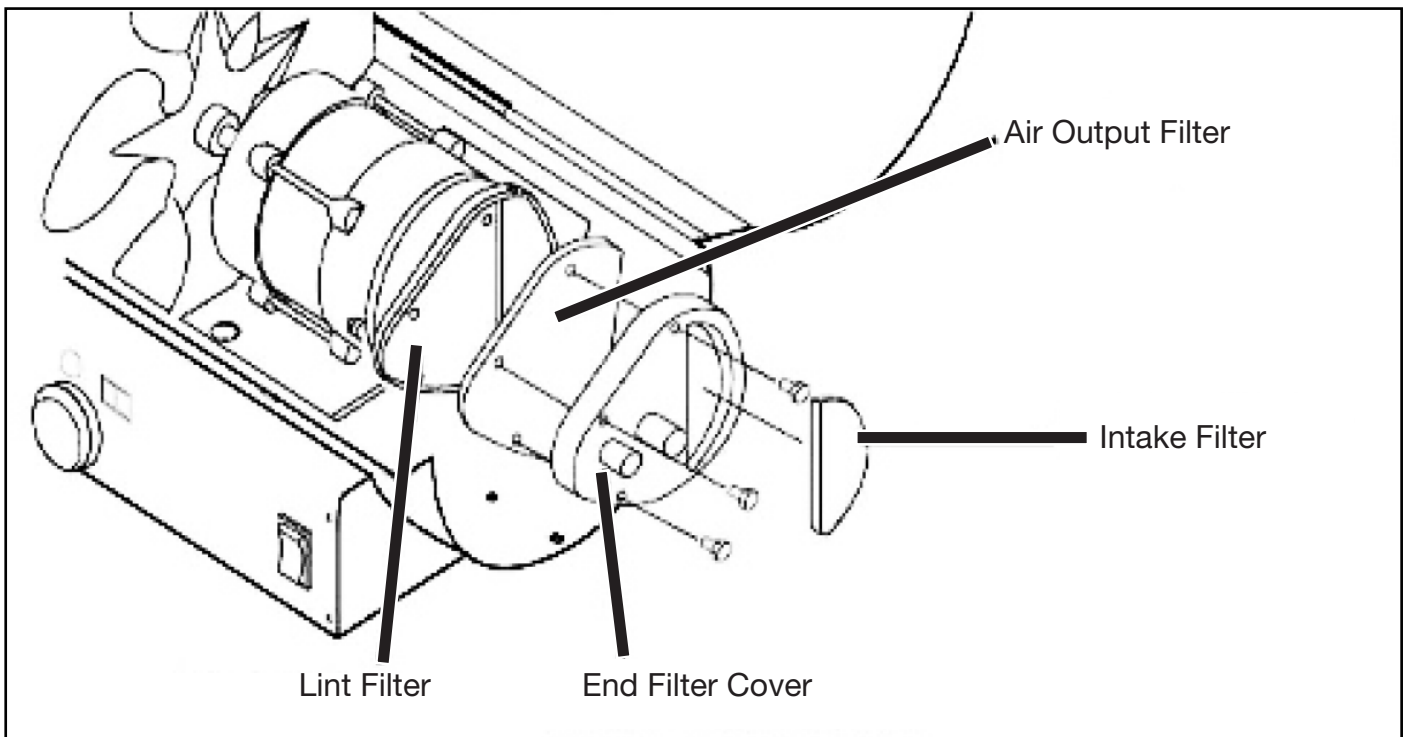

Maintenance & Care

Fan Blades

Blades should be cleaned at least once per heating season, depending on condition. Remove all accumulated dust and dirt with a damp cloth, taking care not to bend any of the fan blades. be sure fan blades are dry before re-starting the heater. For fan removal, see below.

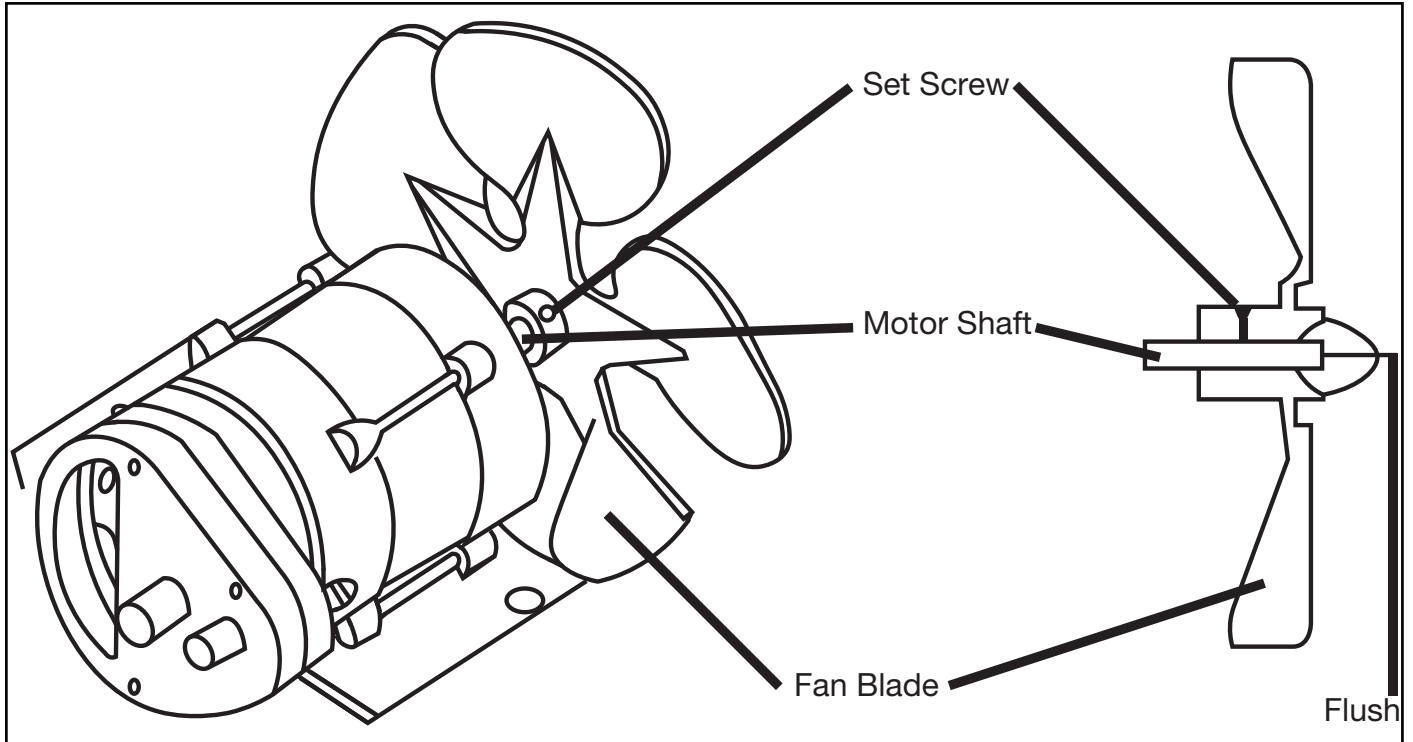

Maintenance & Care

Nozzles

Nozzles should be cleaned or replaced at least once per heating season. Contaminated fuel could make this necessary immediately.

To clean dirt from the nozzle, blow compressed air through nozzle front, it may be necessary to soak nozzle in clean diesel (1-K kerosene) to help loosen any particles.

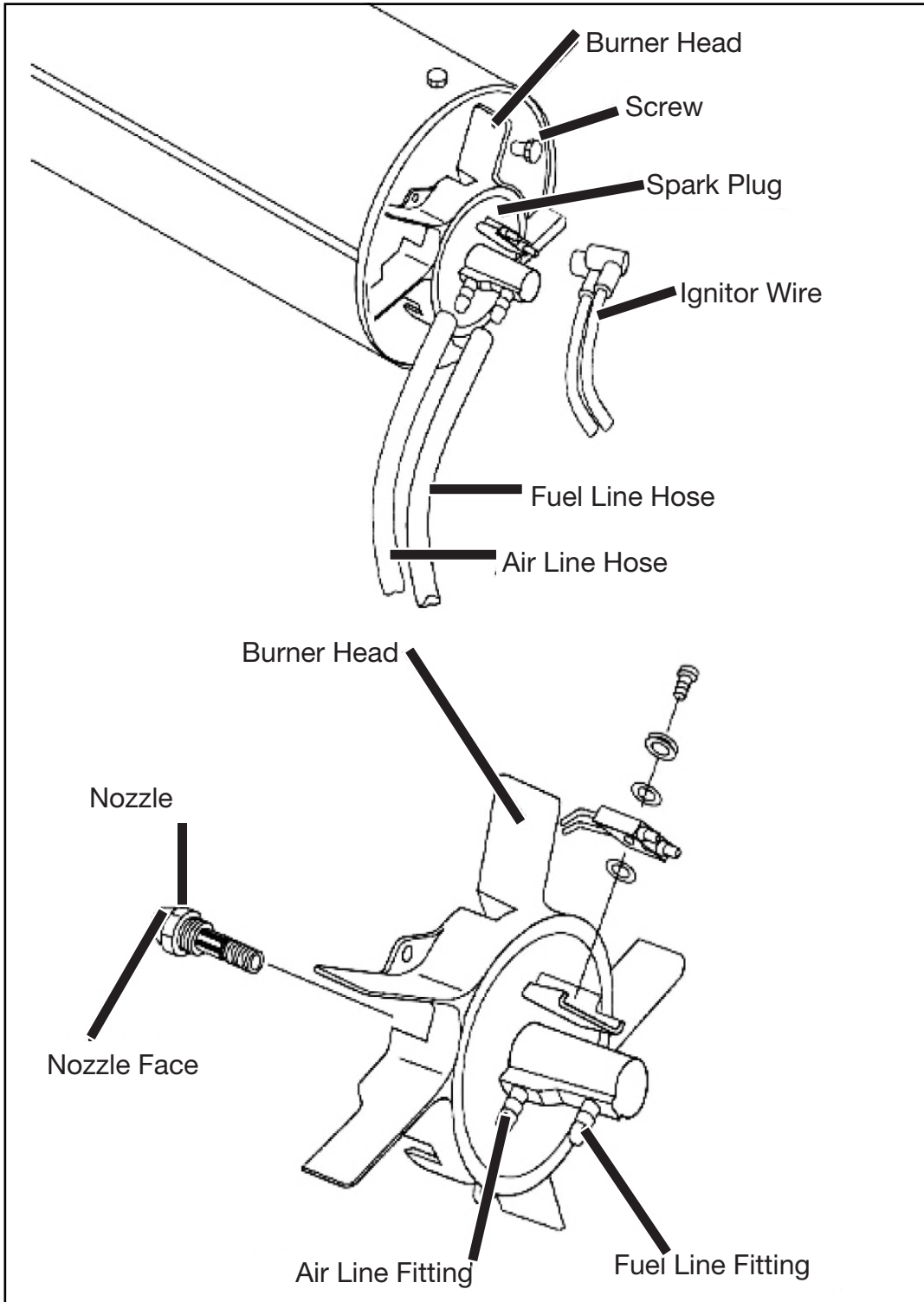

NOTE: Use of diesel (1-K kerosene) may require an additional maintenance. Using this heater without proper maintenance or with contaminated or old fuel may lead to improper combustion and possible soot production. **BE SURE FUEL USED IS APPROVED.**

Maintenance & Care

Spark Plug

Clean and re-gap every 600 hours of operation, or replace as needed. After removing the spark plug, clean the terminals with a wire brush. Re-gap the terminals to 0.35cm.

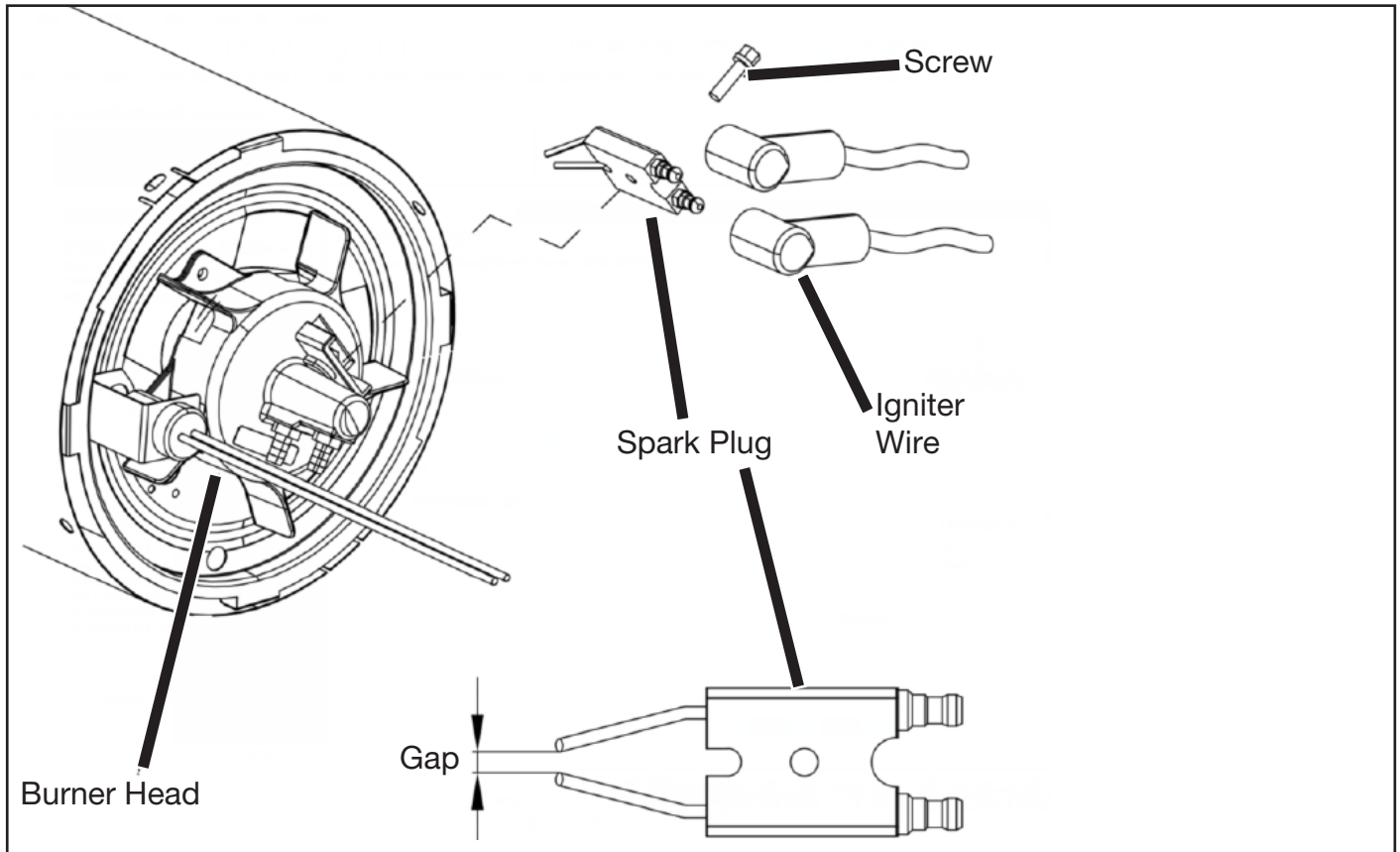

Maintenance & Care

Photocell

The photocell should be cleaned at least once per heating season or more depending on condition. Use a cotton swab dipped in water or alcohol to clean the lens of the photocell. Note the proper photocell position as noted in the diagrams.

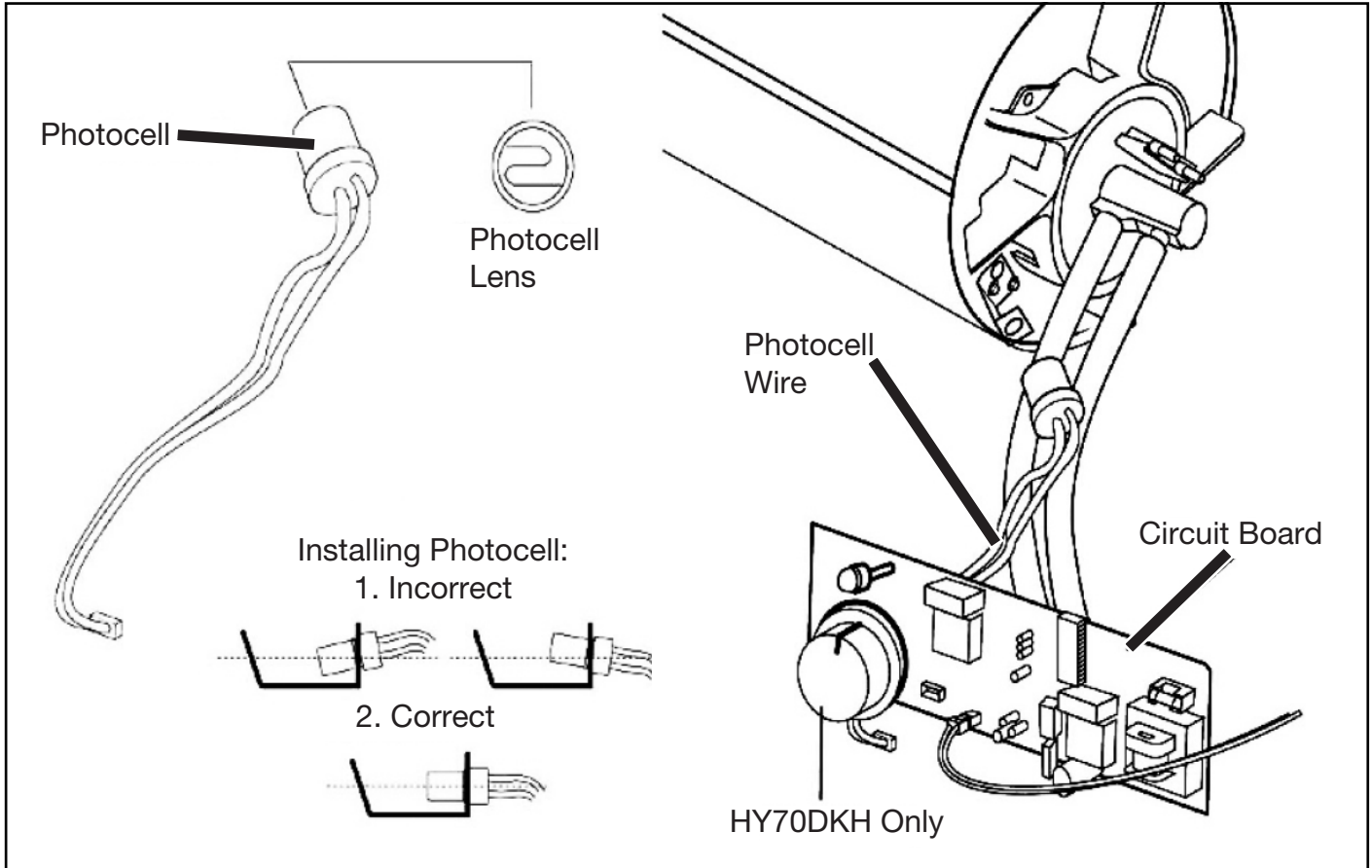

Maintenance & Care

Fuel Filter

Fuel Filter

The fuel filter should be cleaned at least twice per heating season by rinsing it in clean diesel (1-K kerosene). Contaminated fuel could make this necessary immediately.

NOTE: To remove the fuel filter, please draw out the rubber plug directly. Use of diesel may require additional maintenance. **Improper maintenance can lead to poor combustion and soot production.**

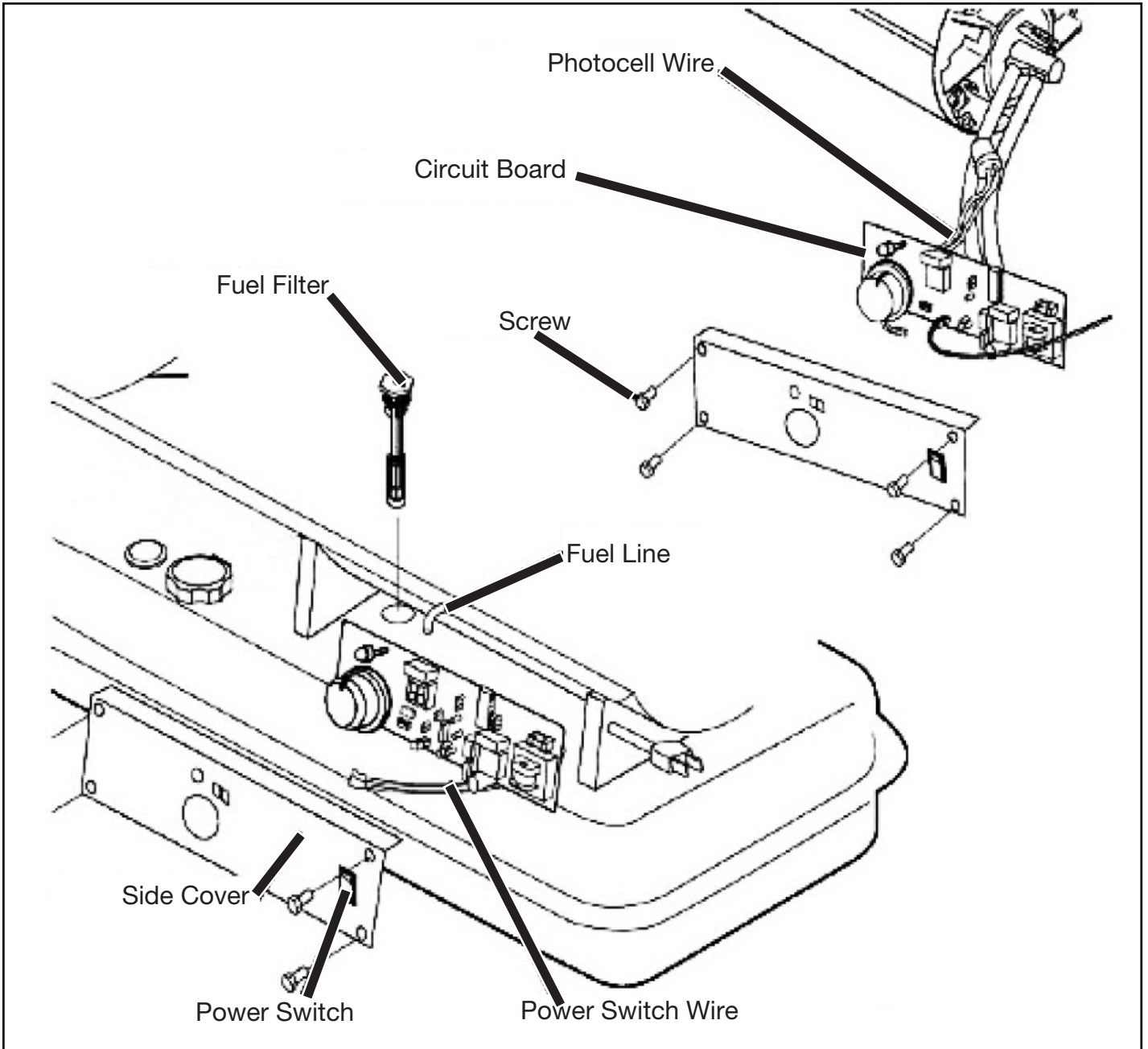

Maintenance & Care

Pump Pressure Adjustment

Pump Pressure Adjustment

While heater is operating, turn relief valve clockwise to increase.

Counter-clockwise to decrease. Use flat blade screw driver to turn valve. Correct pump pressure as follows:

Model	Pump Pressure (Kpa/Psi)
HY125DKH	38.0/5.5
HY215DKH	52.0/7.5

For best measurement of pressure, test with full tank of fuel. **Optimum pressure occurs when the nose cone is cherry red and there are no extending flames from the heater.**

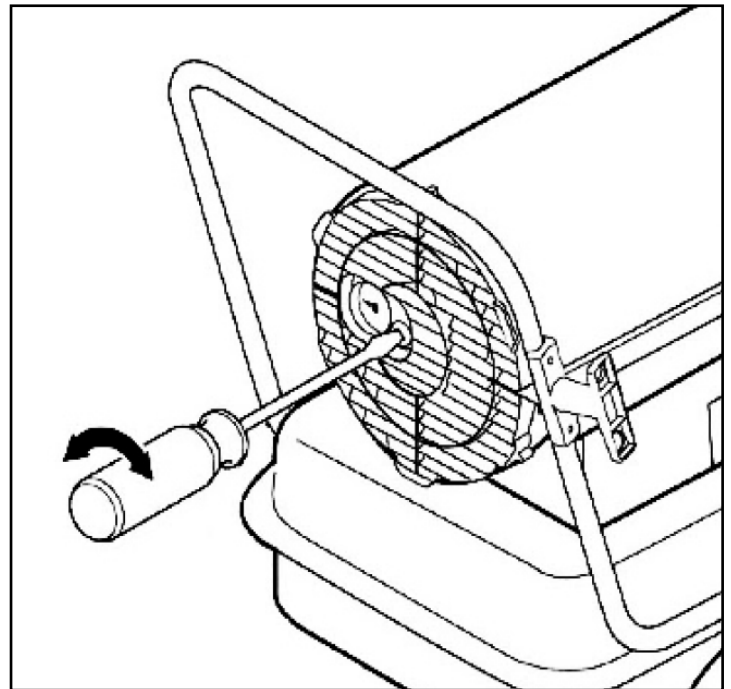
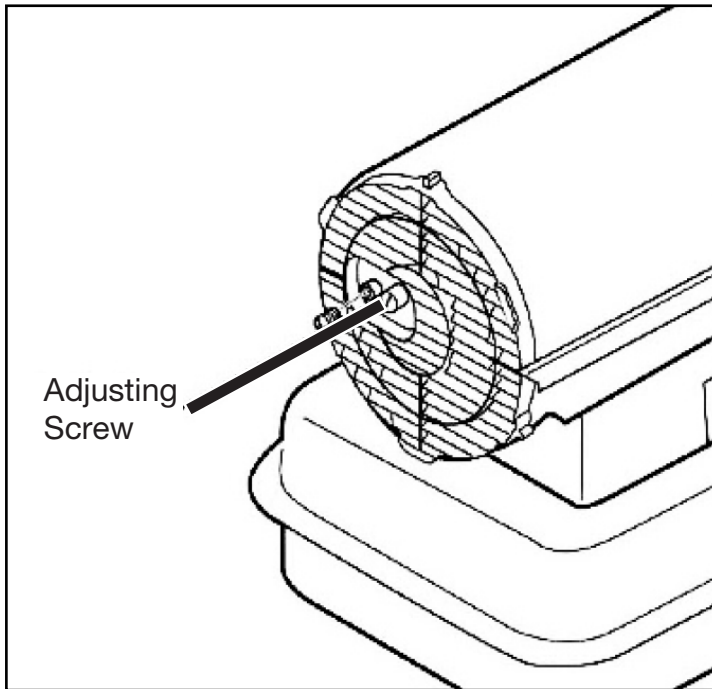

Maintenance & Care

Fuse Replacement

STEP 1 - Switch Off and Remove Control Panel

1. Before working on the unit, YOU MUST ensure it is NOT connected to mains power supply. If unit is plugged into a power source, turn the machine switch to off position, turn the socket switch off, then remove from socket.

2. With a 7mm Spanner OR Phillips Screwdriver, remove the 4 bolts in each corner of the control panel as shown.



3. With the bolts removed, gently pull the control panel away from the unit body, exposing the control board.

Rest the control panel on the unit frame, allowing it to hang may cause damage to the wiring.

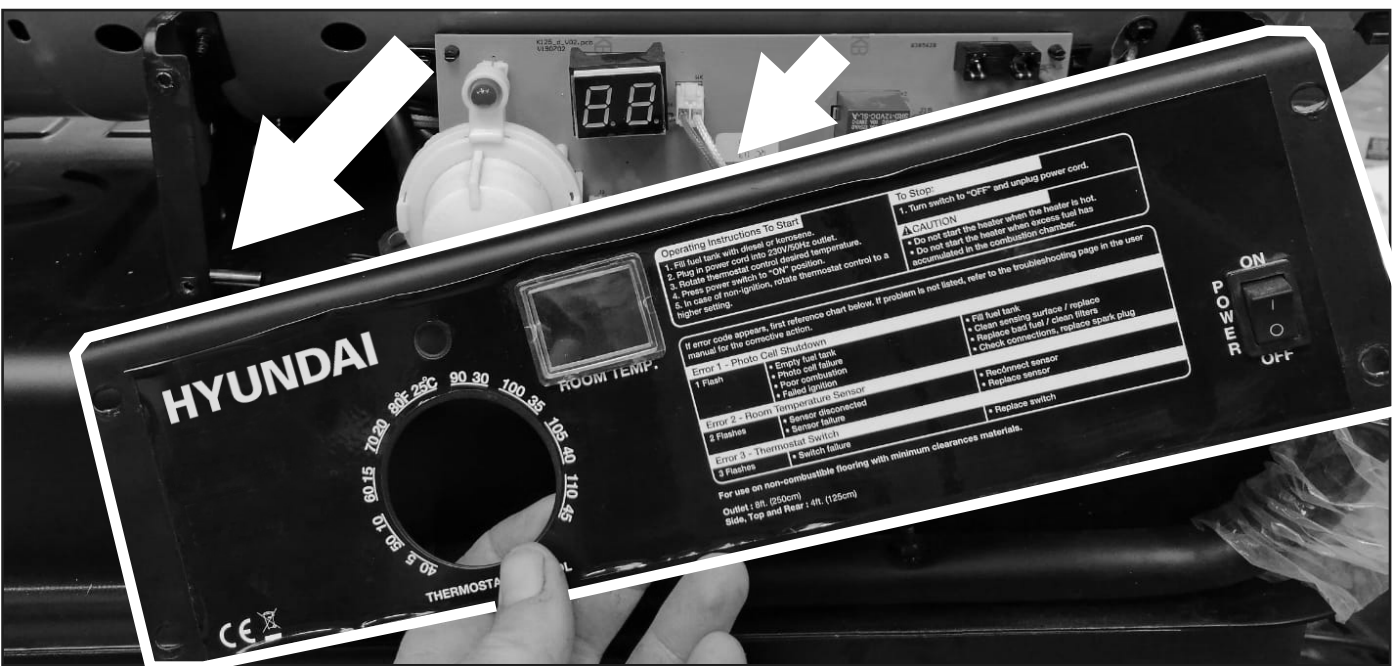

Maintenance & Care

STEP 2 - Remove and Replace Fuse

1. Locate the fuse on the control board.

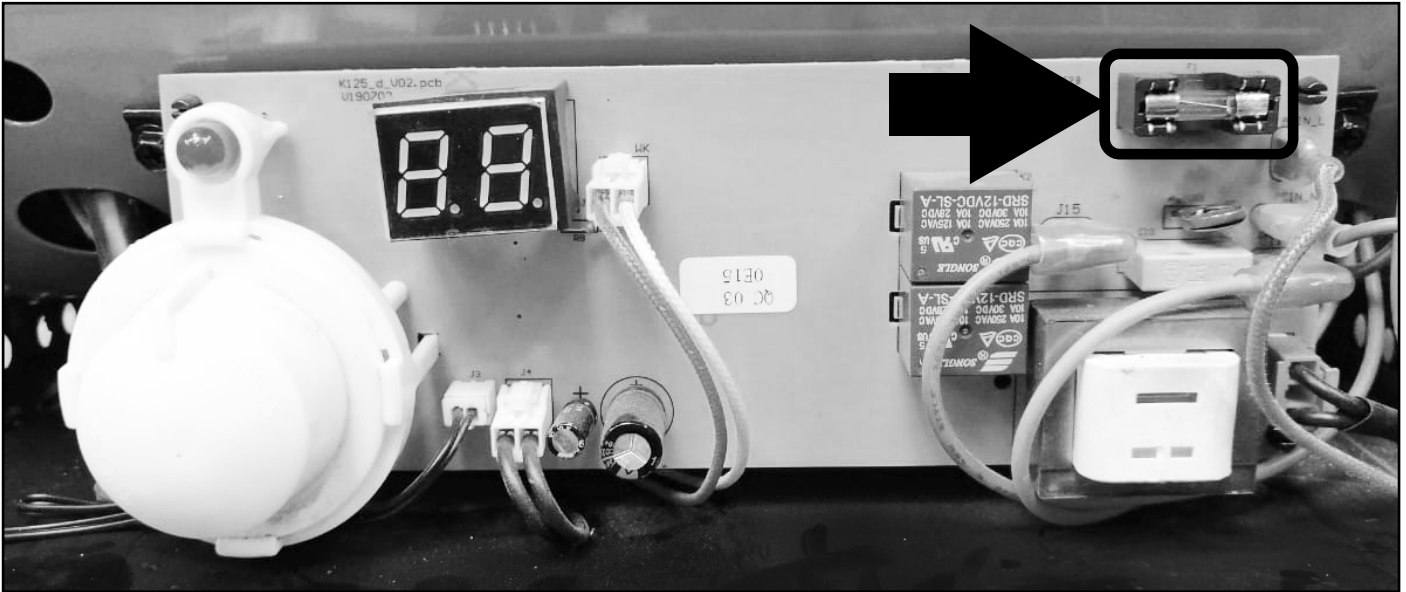

2. Pull the fuse from its holder.

3. Gently insert a new 5 amp glass fuse into fuse holder. DO NOT use too much force, you may cause damage to the fuse and/or the holder.

Repeat the instructions from 'Step 1 - Remove Control Panel' in reverse to return the unit to a useable state.

4. To test if the replacement has been successful, plug the machine into a power source. Put the power source and unit switches to the On position. The Room Temperature display should illuminate.

If you have followed these steps and the temperature display does not illuminate, please contact technical support.

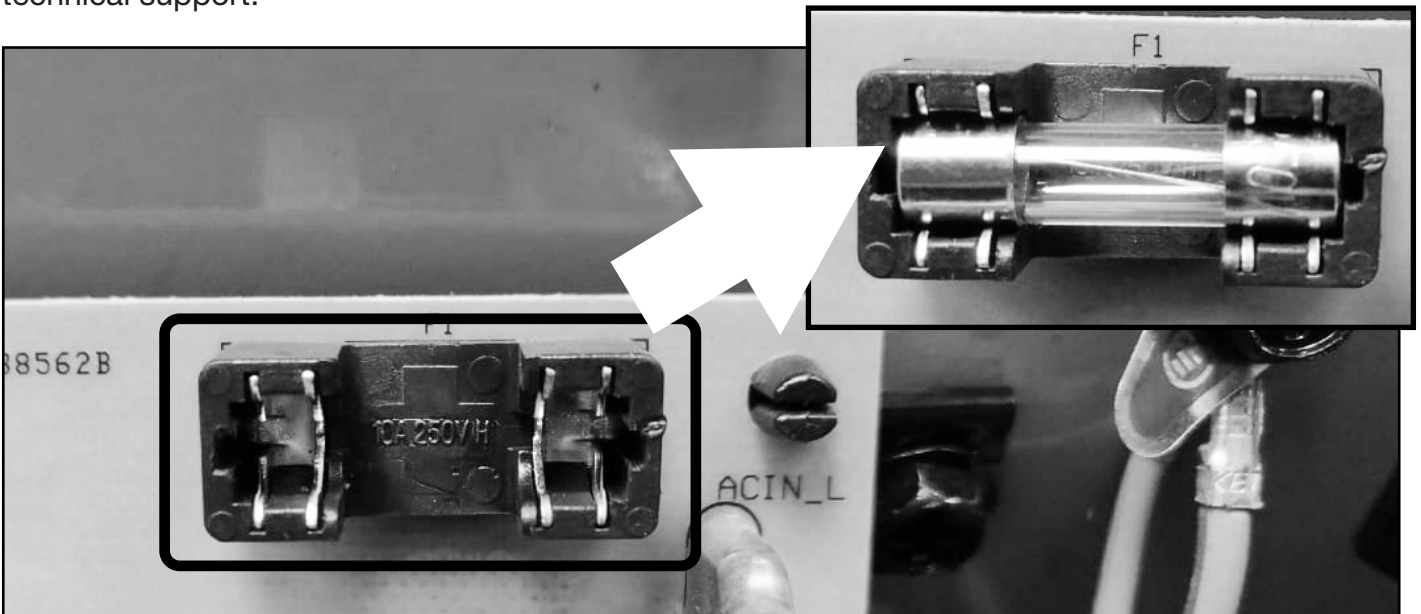

Maintenance & Care

Troubleshooting

Problem	Possible Cause	Solution
Heater fires, but main PCB shuts heater off after a short period of time, flame is flickering, and LED display show "E1" (1 flash).	<ol style="list-style-type: none"> 1. Incorrect pump pressure. 2. Dirty input output or lint filter. 3. Dirty fuel filter. 4. Nozzle is dirty. 5. Photocell lens is dirty. 6. Photocell not installed properly. 7. Photocell defective. 8. Improper electrical connection between main PCB and photocell. 	<ol style="list-style-type: none"> 1. Adjust pump pressure. 2. Clean/replace air filter. 3. Clean/replace fuel filter. 4. Clean/replace nozzle. 5. Clean/replace photocell. 6. Adjust photocell position. 7. Replace photocell. 8. Check wiring connections.
Heater will not operate, or motor runs for short time, lamp flickers and LED display shows "E1" (1 flash).	<ol style="list-style-type: none"> 1. No diesel in fuel tank. 2. Incorrect pump pressure. 3. Corroded spark plug or incorrect plug gap. 4. Dirty fuel filter. 5. Dirty nozzle. 6. Moisture in fuel/fuel tank. 7. Improper electrical connection between transformer and circuit board. 8. Igniter wire not connected to spark plug. 9. Detective igniter. 	<ol style="list-style-type: none"> 1. Fill tank with fresh diesel. 2. Adjust pump pressure. 3. Clean/replace spark plug. 4. Clean/replace fuel filter. 5. Clean/replace nozzle. 6. Rinse out fuel tank with clean fresh diesel. 7. Inspect all electrical connection (see wiring diagrams). 8. Re-attach igniter wire to spark plug. 9. Replace igniter.
Fan does not operate when heater is plugged in and power switch is in the "ON" position. The lamp is flickering or on and LED display shows "E1" or "E2" (1 flash or 2 flashes).	<ol style="list-style-type: none"> 1. Thermostat is set too low. 2. Broken electrical connection between main PCB and motor. 	<ol style="list-style-type: none"> 1. Rotate thermostat to a higher setting. 2. Inspect all electrical connection (see wiring diagrams).
Lamp is flickering, and LED display shows "E3" (3 flashes).	<ol style="list-style-type: none"> 1. Thermostat switch has failed. 	<ol style="list-style-type: none"> 1. Replace thermostat switch, wiring diagrams.
Poor combustion and / or excess soot production.	<ol style="list-style-type: none"> 1. Dirty input output or lint filter. 2. Dirty fuel filter. 3. Poor quality of fuel. 4. Pump pressure is too high or too low. 	<ol style="list-style-type: none"> 1. Clean/replace air filter. 2. Clean/replace fuel filter. 3. Be sure fuel is not contaminated or old. 4. Use proper pressure.
Heater does not turn on and the lamp is not lit.	<ol style="list-style-type: none"> 1. Temperature limit sensor has overheated. 2. No electrical power. 3. Fuse blown. 4. Improper electrical connection between temperature limit sensor and circuit board. 	<ol style="list-style-type: none"> 1. Push power switch to "OFF" and allow heater to cool for 10 minutes. Push switch back to "ON". 2. Check power cord and extension cord to insure of proper connection, test power supply. 3. Check/replace fuse. 4. Inspect all electrical connection (see wiring diagram).

Technical Data

Wiring Diagram

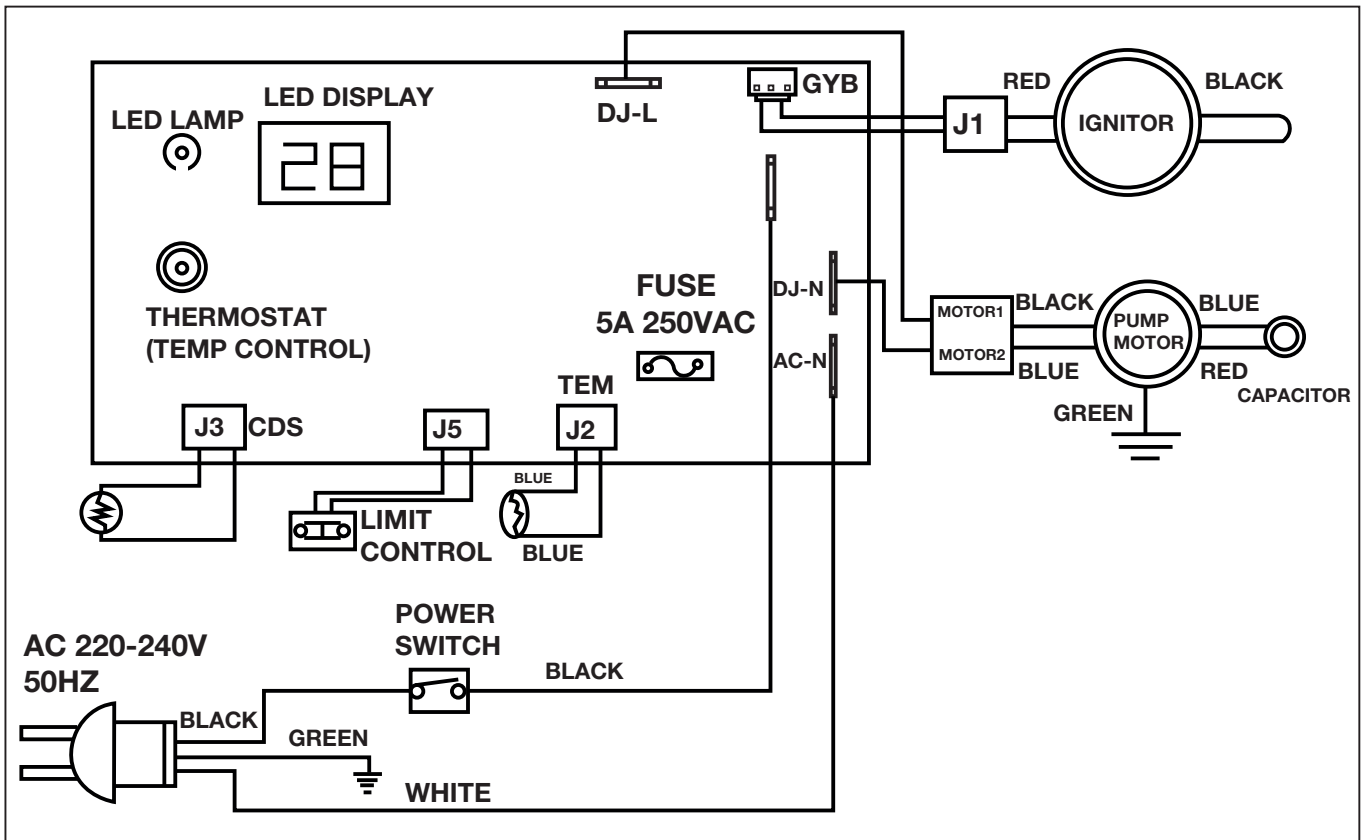

Technical Data

Specifications

Model	HY125DKH	HY215DKH
Heat Output (kW)	37	63
Fuel Consumption (L/Hr)	3.6	5.8
Fuel Tank Capacity (L)	38	50
Fuel	Diesel or Kerosene	Diesel or Kerosene
Max. Outlet Air Temperature	404°C	516°C
Pump Pressure (Kpa)	38	52
Power Supply (V/Hz/A)	230/50/5	230/50/5
Phase	Single	Single
Net Weight (kg)	22.1	23.5

Product Dimensions

Model	HY125DKH	HY215DKH
Length	105cm	120cm
Width	54.2cm	60cm
Height	62cm	62cm

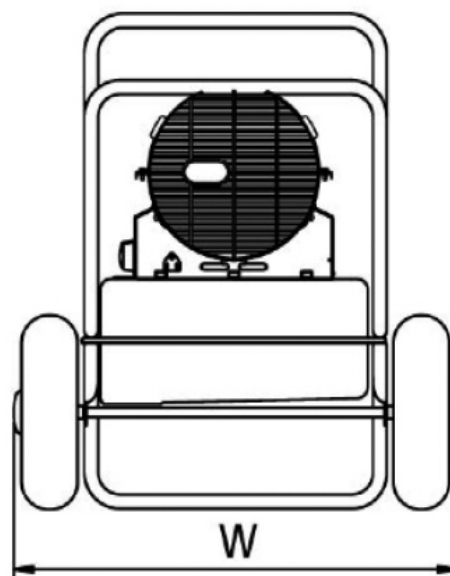
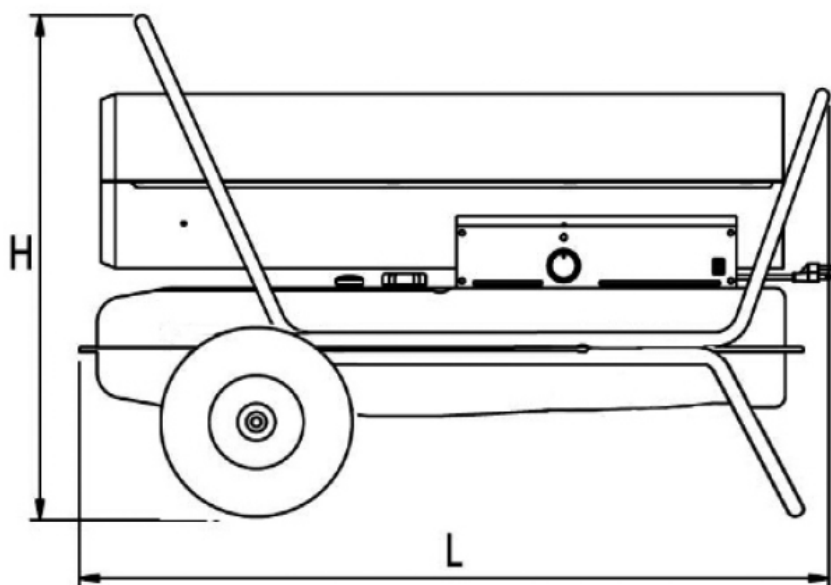

Technical Data

EU Declaration of Conformity

Importer and Authorised Representative

Genpower Ltd
Isaac Way, Pembroke Dock, SA72 4RW

Country of Origin: China
Description: Space Heater
SKU Code: HY125DKH / HY215DKH
Date of Issue: 14/05/2021

Regulations and Directives of Compliance

- 2014/35/EU Low Voltage Directive
- 2009/125/EC Energy-Related Products (ERP)
- 2014/30/EU Electromagnetic Compatibility Directive
- 2011/65/EU RoHS 2.0 Directive
- EN 13842:2004 Oil fired forced convection air heaters. Stationary and transportable for space heating.

Statement of Declaration

We the importer and authorised representative of the product described confirm conformity within the provisions of applicable regulations and directives listed within this document.

Signed on Behalf of Genpower Ltd

Place of Issue: Genpower Ltd
Signatory Name: Roland Llewellyn
Position: Managing Director

RJLlewellyn



Recycling & Disposal

Recycling & Disposal



We do not offer a takeback scheme for the recovery of Waste Electrical Electronic Equipment (WEEE) & Batteries. Instead the responsibility to dispose of WEEE and/or Batteries is passed onto you by us.

So when it becomes necessary to dispose of your machine you must take it to your local Civic Amenity Site. For further information please contact your local Authority for disposal advice.

You **MUST** make sure that all unused oil and fuel is disposed of correctly either beforehand or at your local Civic Amenity Site.

- Under NO circumstances must any fuel or oil be put down any drains.
- Certain products contain WEEE waste which should not be disposed of in your domestic waste.
- You **MUST** recycle WEEE in accordance with your local authority or recycling centre.
- Certain products contain batteries which should not be disposed of in your domestic waste.
- You **MUST** recycle batteries in accordance with your local authority or recycling centre.
- Unwanted packaging and materials should be stored and taken to a recycling centre so it can be disposed of in a manner which is compatible with the environment.

We are a Member of the VALPAK National Compliance Scheme and our registration number is **RM08660**. For further information about disposal please contact your Local Authority.

You can also get more advice and guidance about recycling at the following website <http://www.recycle-more.co.uk>

Should you pass this product on to another user either sold or loaned, you **MUST** pass on this user manual. This will make sure that all other users can use and maintain this machine safely.

Environmental Protection

1. Environmental protection should be a priority of considerable importance when using the machine, for the benefit of both social coexistence and the environment in which we live. Try not to cause any disturbance to the surrounding area.
2. You must comply with local regulations and provisions for the disposal of packaging, oils, petrol, filters, damaged parts or any elements which have a strong impact on the environment. This waste must not be disposed of as normal waste. It needs to be separated and taken to specified waste disposal centres where the material will be recycled.
3. You must comply with local regulations for the disposal of waste materials after mowing.
4. When disposing, do not pollute the environment with the machine, but hand it over to a disposal centre, in accordance with the local laws in force.

Useful Information

Check Out Our YouTube Channel

Our videos on YouTube include:

- Unboxing
- Assembly of your machine
- How to service your machine
- Products in use
- 'How To' videos
- Product features

Go to www.hyundaisupport.co.uk or search 'Hyundai Power Products' in YouTube.

Warranty

Proof of purchase will be required before you make a warranty claim.

Full warranty terms and conditions can be found on the HYUNDAI POWER PRODUCTS website: www.hyundaipowerproducts.co.uk

Manual Updates

Our manuals are constantly being reviewed and updated. Should you find an error, omission or something unclear, please contact us for assistance.

We reserve the right to make any modifications without prior notice whenever necessary.

Our latest manuals are also placed online.

All our manuals can be downloaded at: www.hyundaipowerproducts.co.uk

Returning Your Product

If you are returning your product, please contact the dealer for their returns policy.

Leaving A Review

We work very hard to give all of our customers the best possible service. If you have any problems, before leaving negative feedback, please contact us to give us a chance to resolve the issue. We would be delighted if you left us positive feedback!

To leave a review, please go to: uk.trustpilot.com/review/hyundaipowerequipment.co.uk

Ordering Spare Parts

You can find the spare part you are looking for in the 'Spare Parts' section of this manual or visit power-spares.co.uk

Product Information

Product Record

As soon as you have purchased the machine, we recommend that you fill out the following. If you need to contact an authorised dealer or customer service for information on servicing, you may need to provide the following information.

The model number and serial number can be found on the grey specification sticker on your machine.

Date Of Purchase:

Dealer Name:.....

Dealer Phone:.....

Model Number:.....

Serial Number:.....



Contact Us

Need help? Talk to our experts

Our friendly aftersales team will be more than happy to help you.



Phone

Call our team on 01646 687880, open Monday-Friday 8.30am-5pm.



Email

aftersales@hyundaipowerproducts.co.uk



Online Live Chat

Go to www.hyundaipowerproducts.co.uk

Live chat is open Monday-Friday from 8.30am-5pm.



Post

Genpower Limited, Isaac Way, Pembroke Dock, Pembrokeshire, SA72 4RW, UK.

HYUNDAI

POWER PRODUCTS

Importer:
GENPOWER LTD
Isaac Way, London Road,
Pembroke Dock, UNITED KINGDOM, SA72 4RW
T: +44 (0) 1646 687 880 F: +44 (0) 1646 686 198
E: info@hyundaipowerproducts.co.uk
www.hyundaipowerproducts.co.uk

Imported/Distributed by Genpower Ltd for The United Kingdom & Ireland

Licensed by Hyundai Corporation, Korea

