

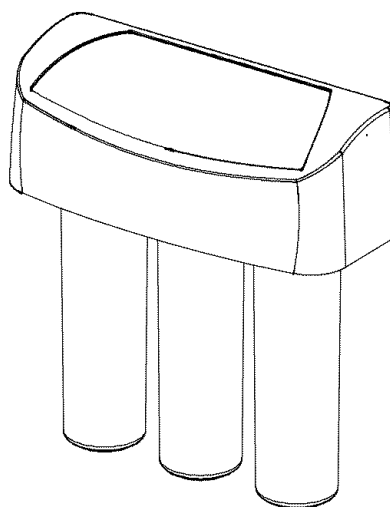

Model WHER12

Model WHER18

How to install, operate and
maintain your Reverse Osmosis
Drinking Water System



Do not return R.O. to store

If you have questions or concerns when
installing, operating or maintaining your
R.O. call our toll free number:

1-866-986-3223

Monday - Friday, 8 am - 9 pm EST

System tested and certified by NSF International
against NSF/ANSI Standard 58.
See performance data sheet for details.



Installation and Operation Manual

7263942 (Rev. D 8/18/04)
Product No. 8562920

Table of Contents

Before You Start	3
Inspect Shipment	4
Reverse Osmosis Information	5
How the RO System Works	5
Prefilter	5
Reverse Osmosis (RO) Cartridge	5
Storage Tank	5
Post Filter	5
Faucet	5
Faucet Electronics	6
Shutoff Assembly	6
Check Valve	6
Flow Control	6
Reverse Osmosis Dimensions	7
Plan the Installation	7
Tools and Materials Needed	7
Location Requirements	7
Remote Locations	7
Air Gap Requirements	8
Installation	9
Install Cold Water Supply Fitting	9
Install Drain Adaptor	10
Install Faucet	11
Install RO Assembly	13
Install Storage Tank, Make Remaining Tubing Connections	13
Sanitize, Pressure Test & Purge	14
Routine Maintenance	16
Prefilter and Post Filter Cartridges	16
RO Membrane Cartridge	17
Flow Control	18
Tubing Connection	18
Automatic Shutoff	19
Troubleshooting Guide	20
Specifications	21
Repair Parts	22
Product Schematic	24
Warranty	24

Before You Start

For installations in the Commonwealth of Massachusetts:
Installation by a licensed plumber is required. Plumbing code 248-CMR of the Commonwealth of Massachusetts must be used for installation.

Read all steps and guides carefully before installing and using your reverse osmosis system. Follow all steps exactly to correctly install. Reading this manual will also help you to get all the benefits from the reverse osmosis system.

Do not attempt to use this product to make safe drinking water from non-potable water sources. Do not use the system on microbiologically unsafe water, or water of unknown quality without adequate disinfection before or after the system. This system is certified for cyst reduction and may be used on disinfected water that may contain filterable cysts.

Some or all of the contaminants listed may not be in your water supply.

All plumbing should be done in accordance with local codes and requirements.

This system shall only be used for arsenic reduction on chlorinated water supplies containing detectable residual free chlorine at the system inlet. Water systems using an inline chlorinator should provide a one minute chlorine contact time before the RO system. Conforms to NSF/ANSI 58 for pentavalent arsenic reduction. See performance data sheet and Arsenic Facts section for an explanation of reduction performance.

This system is acceptable for treatment of influent concentrations of no more than 27 mg/L nitrate and 3 mg/L nitrite in combination measured as N and is certified for nitrate/nitrite reduction only for water supplies with a pressure of 280 kPa (40 psig) or greater. This system is supplied with a nitrate/nitrite test kit. Product water should be monitored periodically according to the instructions provided with the test kit.

The reverse osmosis system works on water pressures of 40 psi (minimum) to 100 psi (maximum). If you have questions about your water pressure, contact a licensed plumber.

For indoor use only. Certification claims are for temperatures of the water supply to the reverse osmosis system of 40°F to 100°F. Install on the cold water line.

To see if your water is within the required specifications, read the water specifications to be sure your water supply is within these limits. TDS test kits are available by calling 1-800-826-8553 ext. 47, or check the water testing section of your local phone directory.

The reverse osmosis membrane may contain a preservative for storage and shipment. Be sure to purge before using product water. See “Sanitize, Pressure Test and Purge” section.

Inspect Shipment

The parts required to assemble and install the reverse osmosis system are included in a parts bag, located inside the shipping carton.

Water supply fitting

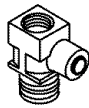

Drain adaptor

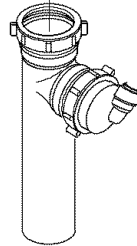

Hanger washers and screws

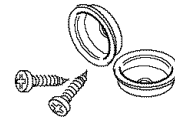

RO product water faucet
(Model WHER12)

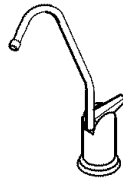

Monitor
(Model WHER18)

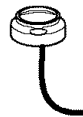

RO product water faucet
(Model WHER18)

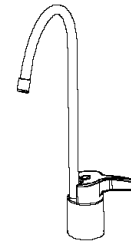

Teflon tape



Tank valve



“AA” batteries
(Model WHER18)



Check the reverse osmosis system for possible shipping damage and parts loss. Also inspect and note any damage to the shipping carton.

Remove and discard (or recycle) all packing materials. To avoid loss of small parts, we suggest you keep the small parts in the parts bag until you are ready to use them.

Reverse Osmosis Information

The Reverse Osmosis (RO) Drinking Water System is a water treatment unit. It uses household water pressure to reverse a natural physical process called osmosis. Water, under pressure, is forced through a semi-permeable membrane where minerals and impurities are filtered out. Clean drinking water goes to the faucet or storage tank, while minerals and impurities are sent to the drain with RO waste water. The minerals and impurities are measured in water as total dissolved solids (TDS).

The reverse osmosis system includes replaceable pre and postfilter sediment-carbon cartridges. The prefilter removes sand, silt, dirt, rust particles, other sediments, and chlorine from the water supply before it can enter the RO membrane. The postfilter removes any tastes and/or odors that may remain in the water, after passing through the RO membrane, before going to the RO faucet. To prevent water waste, an automatic shutoff valve closes when the RO faucet is closed and the storage tank is full.

The reverse osmosis system gives a continuous supply of sparkling clear, delicious water for drinking, cooking and other uses. The reverse osmosis process makes water very slowly, that is why there is a 2.3 gallon* storage tank. This will enable you to have high quality R.O. product water for your cooking and drinking water needs.

* Exact storage capacity depends on water pressure.

How a Reverse Osmosis System Works

Prefilter

Water from the cold water supply pipe enters the RO assembly prefilter first. The prefilter has a replaceable sediment cartridge with activated carbon in its composition. The cartridge removes sand, silt, dirt, other sediments, and up to the ppm of chlorine shown in the specifications from the feed water. See “Product Specifications” section. Chlorine can adversely effect the RO membrane life. Filtered, clean, chlorine-free water flows from the prefilter, to the RO membrane cartridge.

Reverse Osmosis (RO) Cartridge

The RO cartridge is a tightly wound special membrane. The membrane removes the dissolved solids and organic matter when water is forced through the cartridge. High quality product water exits the RO cartridge and goes to the storage tank, or to the postfilter and RO faucet. Reject water, with the dissolved solids and organic matter, is routed through the flow control and to the drain.

Storage Tank

The storage tank holds up to 2.3 gallons of product water. The higher the incoming water pressure, the more water will be stored in the tank, up to 2.3 gallons. A diaphragm inside the tank keeps water pressurized to about 30 psi, when the tank is full, to provide fast flow to the RO faucet. The dry side of the diaphragm that divides the tank is pressurized with air to 5 - 7 psi.

Post Filter

After leaving the storage tank, but before going to the RO faucet, product water goes through the post filter. The post filter is an activated carbon type filter. Any remaining tastes and odors are removed from the product water. Taste-free, odor-free, clean, high quality drinking water is available for use.

Faucet

The sink or countertop faucet has a hand operated lever or knob to access drinking water. To comply with plumbing codes, an air-gap is built into the faucet drain water connection.

Faucet Electronics

If so equipped, the RO system will monitor the total product flow of the reverse osmosis system and also length of time the filters have been installed. The faucet base has an indicator light that flashes to inform you of the status of the RO membrane and filters. This indicator light will flash only when water is flowing.

- Green - RO membrane and filters are good.
- Amber - Warning, pre and post filters will need replacing shortly. Filters need replacing, when water has been drawn, after 182 days (or 750 gallons have been used).
- Red - RO membrane needs to be replaced.

When the two “AA” batteries are first applied at initial start up, the LED indicator light will flash in a red, amber, green sequence. All timers and counters are reset to zero.

In order to reset the monitor time and gallon count feature, the batteries should be removed for a minimum of five seconds and then reinserted.

Batteries need to be replaced once a year at the time of filter replacement. Do not mix battery types, use only “AA” alkaline batteries. Improper placement of batteries could damage electronics. Use care when inserting batteries to align them correctly in manifold with the proper polarity.

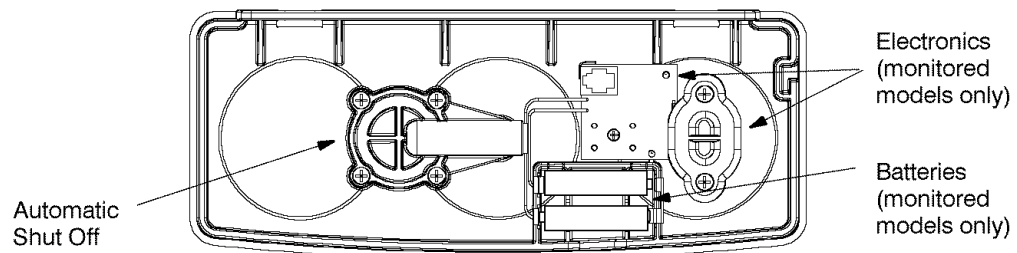

Figure 1

Shutoff Assembly

To conserve water, the drinking water system has an automatic shutoff system. When the storage tank has filled to capacity, and the drinking water faucet is closed, pressure closes the shutoff to stop flow to drain. Pressure in the storage tank is about half of the water supply pressure. After drinking water is used, and pressure in the system drops, the shutoff opens to allow water flow again.

Check Valve

A check valve (Figure 13) is located in the RO manifold, above the center sump. The check valve prevents a backward flow of product water from the storage tank. A backward flow could damage the RO membrane.

Flow Control

Water flow through the RO membrane is regulated by the flow control. It maintains the desired flow rate to obtain the highest quality drinking water. The flow control is located in the end of the 1/4” red drain tubing, at the RO manifold drain port.

Reverse Osmosis Dimensions

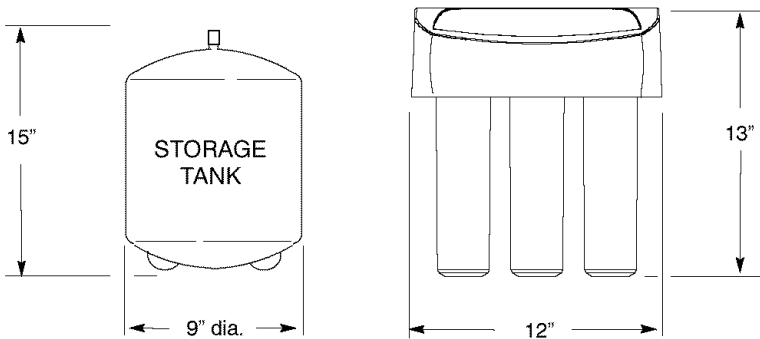

Plan the Installation

Tools and Parts Needed

Assemble the required tools before starting installation. Read and follow the instructions provided with any tools listed here.

- Adjustable wrench
- Larger adjustable jaw pliers
- Screwdrivers
- Electric drill and drill bit
- Pliers
- Pipe wrench
- Plumbers putty (for sink, if necessary)

Location Requirements

Consider all of the following when selecting an installation location for the reverse osmosis.

- For optimum performance your reverse osmosis system should be installed on softened water.
- To provide supply water to the RO system inlet use the feed supply fitting (provided) or buy and install pipe fittings for tubing connection. See “Install Cold Water Supply Fitting” section.
- A refrigerator ice maker may not operate properly when connected to a reverse osmosis system that has been installed on a water system that operates outside of the specified pressures listed. See “Product Specifications” section.
- Chlorine in the water can adversely effect the RO membrane life. Most cities add chlorine to the water supply to kill bacteria. The prefilter removes chlorine up to the limits shown in the specifications before it enters the RO membrane. It is important to replace the prefilter cartridge at least every 6 months. See “Product Specifications” section.
- Check your water supply. The cold water supply to the RO system must be within certain quality limits. See “Product Specifications” section. If supply water is not within limits, the RO system can not make product water as it should and reduced RO membrane life will result.

Remote Locations

- A basement area underneath the sink
- An adjacent room or closet

Parts needed for remote location:

- Longer lengths of tubing, see “Repair Parts” section
- Telephone style wire extension (purchase separately) may be needed

IMPORTANT: Telephone style wire extension must consist of a male connector on one end and a female connector on the other to keep proper polarity. Polarity may be reversed if a coupler is used and the monitor will not work.

The RO assembly and storage tank is designed for installation under the sink, usually in the kitchen or bathroom. The RO assembly mounts on a wall surface, or can lay on the cabinet floor next to the storage tank. Hanger washers and wood screws are included for cabinet wall mounting. The RO product water faucet installs on the sink, or on the countertop next to the sink.

NOTE: Tubing lengths allow for the removal of the assembly from the hanger washers for servicing. If tubing lengths are shortened for neater appearance, it may be necessary to keep the assembly on the hanger washers for service.

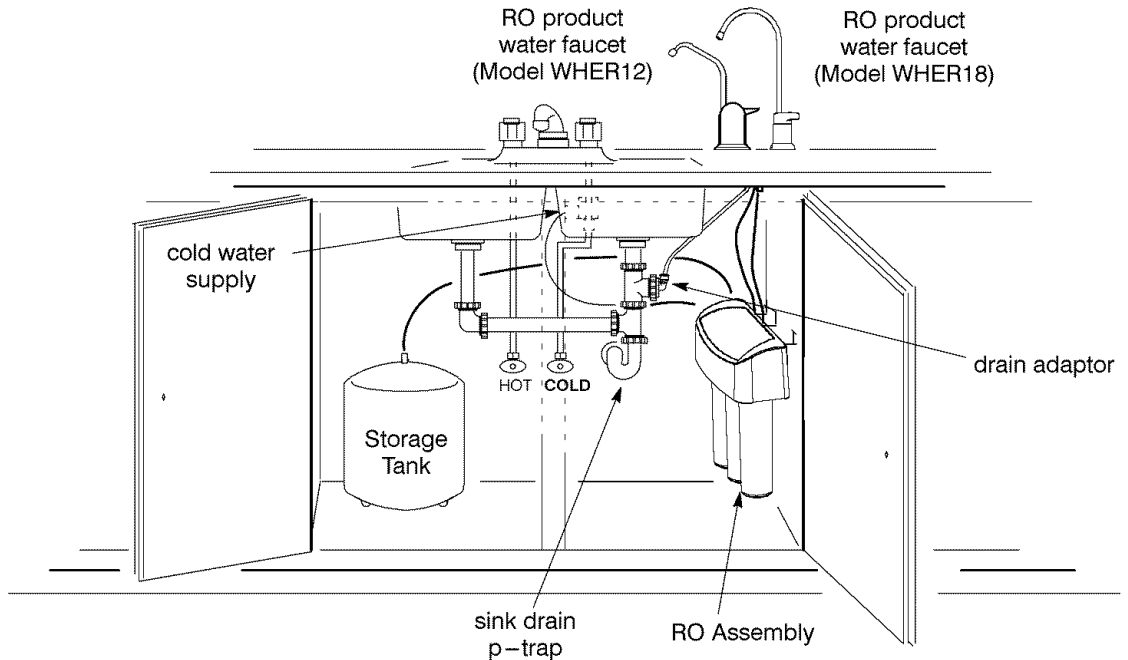
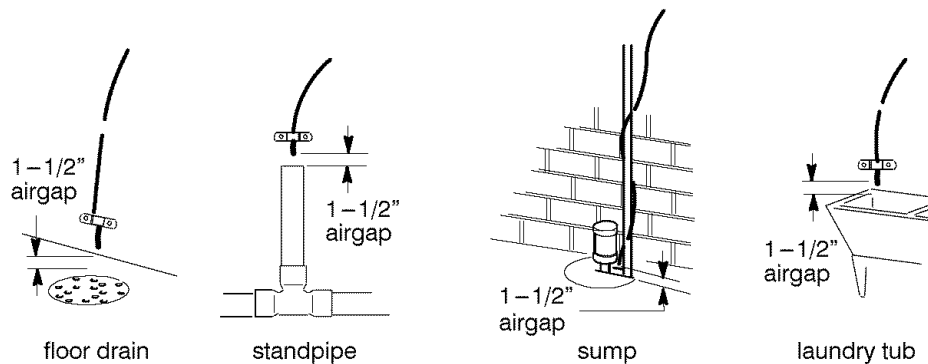

Figure 2

Air Gap Requirements

A suitable drain point is needed for reject water from the RO membrane. A floor drain, laundry tub, standpipe, sump, etc., is preferred. A sink p-trap drain adaptor is included to install where codes permit, as an optional drain point. See “Install Drain Adaptor” section.



Installation

Install Cold Water Supply Fitting

Check and comply with local plumbing codes as you plan, then install a cold feed (supply) water fitting. The fitting must provide a leak-tight connection to the RO 1/4" tubing. A typical connection using the cold water supply fitting (provided) is shown in Figure 3A. An optional connection, using standard plumbing fittings (not provided), is shown in Figure 3B.

Cold water supply fitting:

1. Close the house main water shutoff valve, or shutoff valve on cold water line being connected to, and open faucets to drain water from the sink cold water pipe.
2. Remove nut that connects the cold water faucet to cold water plumbing.
3. Use pipe joint compound or Teflon tape on cold water faucet stud threads and on the male threads of the water supply fitting that connect to the cold water pipe.
4. Thread water supply fitting onto pipe and reconnect nut to bottom of fitting.

Optional Pipe Fittings (compression type shown):

NOTE: Be sure to turn off the water supply and open a faucet to drain the pipe.

1. Install a fitting on the kitchen cold water pipe to adapt 1/4" OD tubing. A typical connection is shown in Figure 3B. If threaded fittings are used, be sure to use pipe joint compound or Teflon tape on male threads.

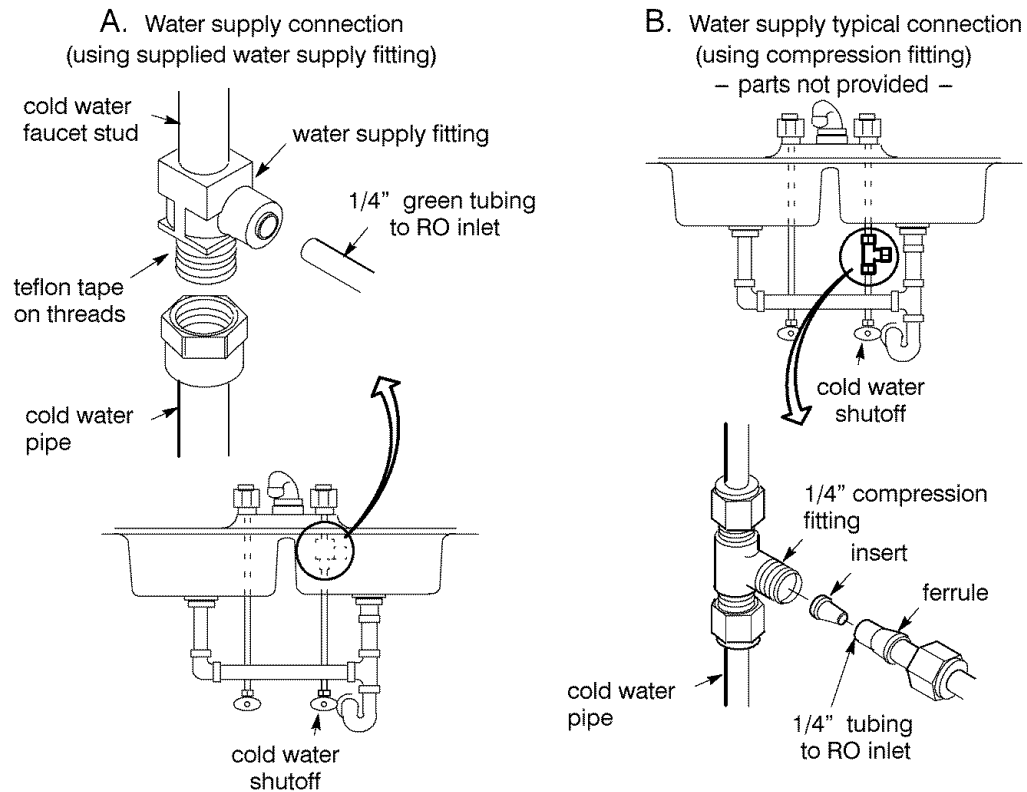

Figure 3

Install Drain Adaptor

Running the drain tubing directly to a floor drain, sump, standpipe, laundry tub is preferred. See “Air Gap Requirements” section. This can also help eliminate noise in the faucet. However, if that is not possible or practical, the drain adaptor (provided) installs in the sink drain pipe, always above or ahead of the p-trap. The drain adaptor fits 1-1/2” sink drain pipe. Other drain pipe fittings, in addition to the adaptor, may be needed. Locate so drain tubing from the faucet makes a straight run to the adaptor, without dips, loops, low spots or kinks.

1. Use a ferrule and nut to assemble the drain tubing connector to the drain adaptor. See Figure 4. Turn the connector to about 45° from the 12:00 position, as shown (to 10:00 or 2:00 position as needed). Tighten the nut securely.

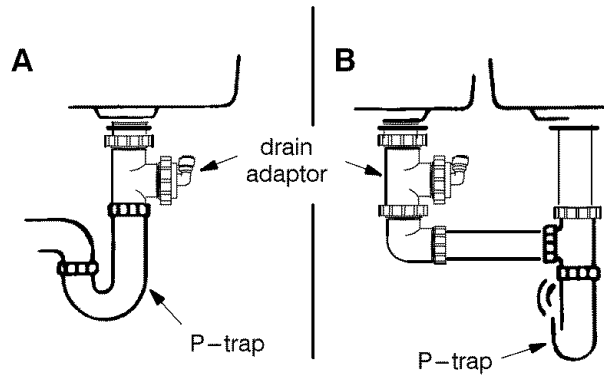

Figure 4

2. Carefully disassemble the sink drain pipe and clean the tailpiece to assure a leak-tight fit.
3. Install the drain adaptor onto the sink tailpiece, using a ferrule and nut. Snug the nut, but do not tighten.

NOTE: If needed, you can cut to shorten the unthreaded end of the adaptor. Do not cut too short or the adaptor will not make a leak-tight seal with the connecting fitting. See Figure 5.

4. Assemble the p-trap to the drain adaptor, and other drain pipe fittings as required (check codes) to complete the drain run.
5. Tighten all connections, but do not overtighten and break plastic fittings.

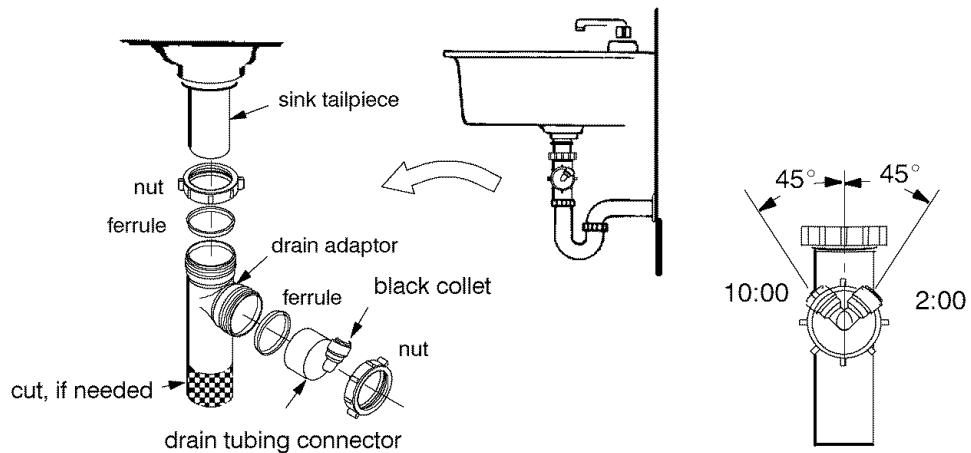

Figure 5

Install Faucet

Prepare mounting hole:

1. Select one of the following places for the faucet. Be sure it will fit flat against the surface, and there is space underneath for tubing (see Figure 9).
 - Use an existing sink top hole for a spray hose or other faucet. A 1-1/4" diameter hole is needed.
 - Drill a new hole in the countertop next to the sink.
 - Drill a new hole in the sink top.

IMPORTANT: To avoid damaging a sink beyond repair, consult a qualified plumber or installer for guides to drill holes in porcelain or stainless steel.

2. Drill a 1-1/4" diameter hole, if necessary.
3. Place plumbers putty around the drilled hole (Figures 6 and 7) to prevent water leakage around the base of the faucet.

Assemble faucet (Model WHER12):

1. Loosely assemble the base, spacer, washer and plastic nut onto the faucet stud.
2. Route the 1/4" red tubing through the sink or countertop hole and connect to 1/4" barb on faucet.
3. Route the 3/8" black tubing through sink or the countertop hole and connect to 3/8" barb on faucet.
4. Attach the 3/8" blue tubing to the faucet stud using the tubing adaptor.
5. Lower faucet into place on the countertop, on the underside of the countertop or sink slide the slotted washer into place and tighten plastic nut. Tighten the nut so the faucet cannot move, but do not overtighten.

Model WHER12

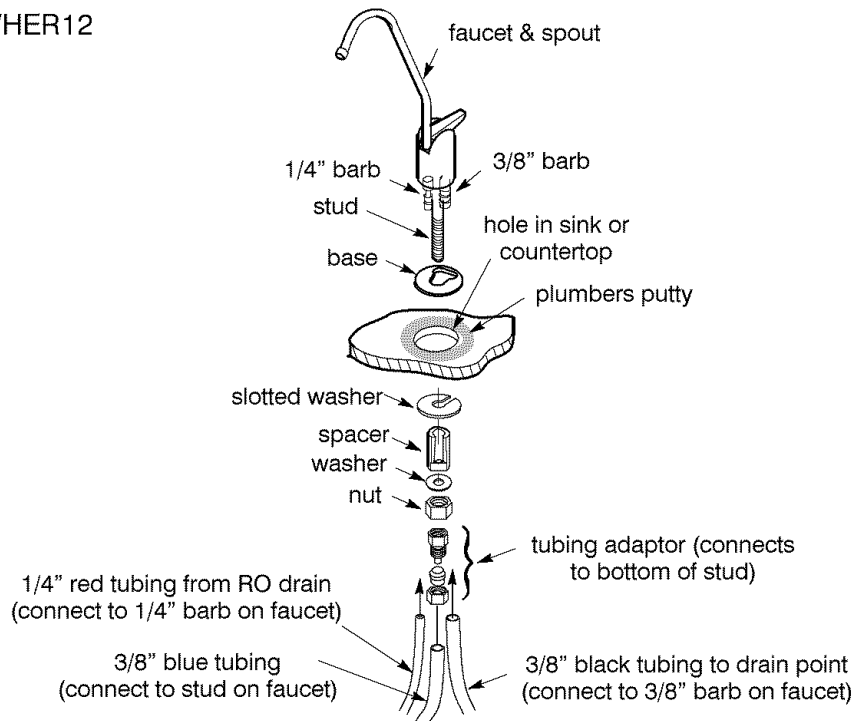

Figure 6

Assemble Faucet (Model WHER18):

1. Slide the electronics ring onto the faucet stud.
2. Route the 1/4" red tubing through the sink or countertop hole, connect to 1/4" barb on faucet.
3. Route the 3/8" black tubing through the sink or the countertop hole, connect to 3/8" barb on faucet.
4. Lower faucet and electronics ring into place on the countertop. On the underside of the countertop or sink, loosely assemble the large spacer, small spacer, washer and brass nut onto the faucet stud. The large spacer can be inverted depending on the thickness of your countertop, if needed.
5. Attach the 3/8" blue tubing to the faucet stud using the tubing adaptor.
6. Route the telephone style wire from the electronics ring through the hole in countertop or sink and through the slot on the right-hand side of the RO manifold. This connects to the receptacle on electronic board located on the RO manifold.
7. Tighten the brass nut. Be sure the telephone style wire is in a position so that it will not be cut, pinched or kinked before tightening the faucet assembly. Tighten the nut so the faucet cannot move, but do not overtighten.

Model WHER18

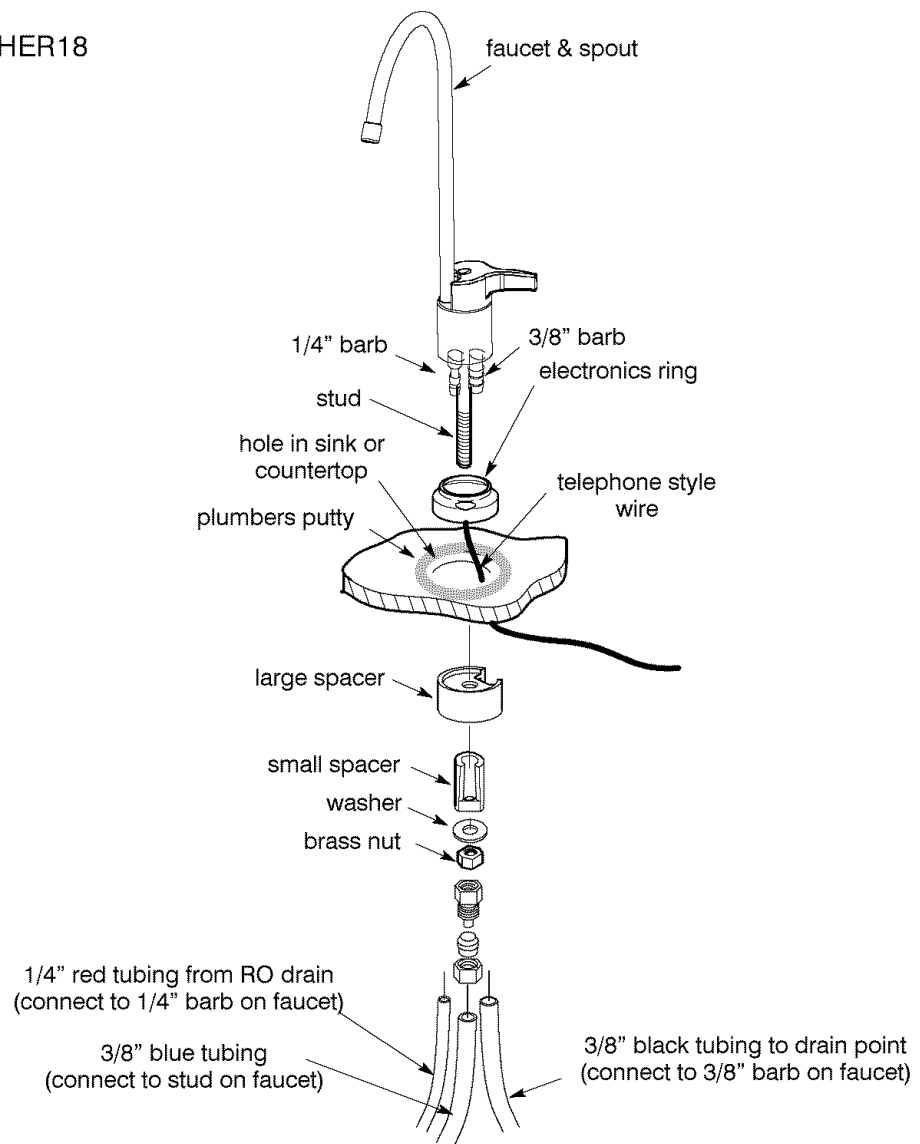

Figure 7

Install RO Assembly

Hang the assembly on the included hanger washers, or lay on the cabinet floor, as desired.

1. Refer to Figure 8 for wall mounting. Hold the assembly up to the wall surface and mark locations for the hanger washers. Distance needed is 7.2" (approx. 7-7/32") apart.
2. Install hanger washers at least 15-1/2" up from the cabinet floor, allowing room to remove sumps from filter heads. Wood screws are provided, or obtain other fasteners as needed.

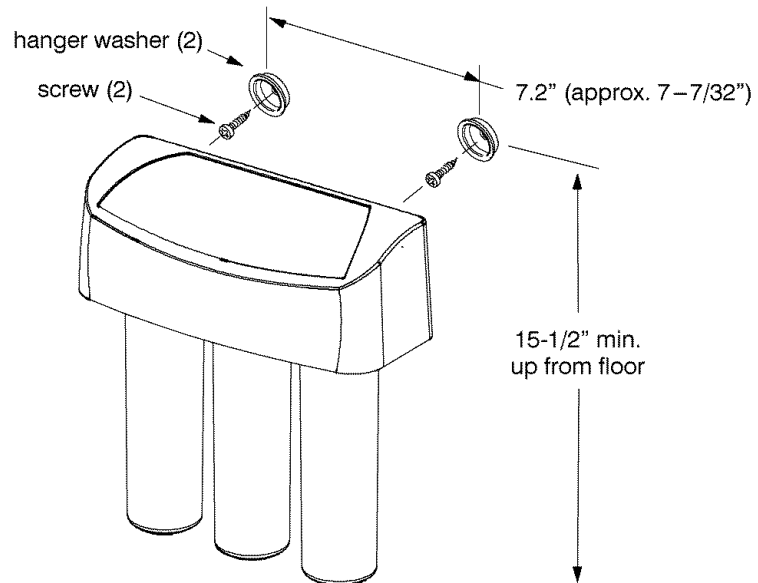

Figure 8

Install Storage Tank, Make Remaining Tubing Connections

1. Connect drain tubing, faucet to drain adaptor: Referring to Figure 9, run the loose section of black 3/8" tubing from the faucet to the drain adaptor, with a black collet. Cut this tubing as needed to route in as straight of a run as possible, without loops, dips, low spots or kinks. Cut the end of the tubing square. Then push all the way into the fitting. Pull on the tubing to be sure it's held firmly in the adaptor fitting. See "Tubing Connection" section.
2. Connect tubing to water supply: Connect the feed (green) tube to the water supply fitting. See "Tubing Connection" section.
3. Move the storage tank into place next to the RO assembly. You can stand the tank upright, or lay it on side. Apply no more than two wraps of Teflon tape to the threads on the nipple at the top of the tank. Hand tighten the tank shutoff valve with the yellow collet onto the tank nipple, then wrench 1/4 turn only. Be careful not to cross thread.
4. Run the 3/8" yellow tubing to the fitting installed above in step 3. Be sure the end of the tubing is cut square, and insert all the way into the fitting. Again, pull on the tubing to be sure it's held firmly in the fitting.

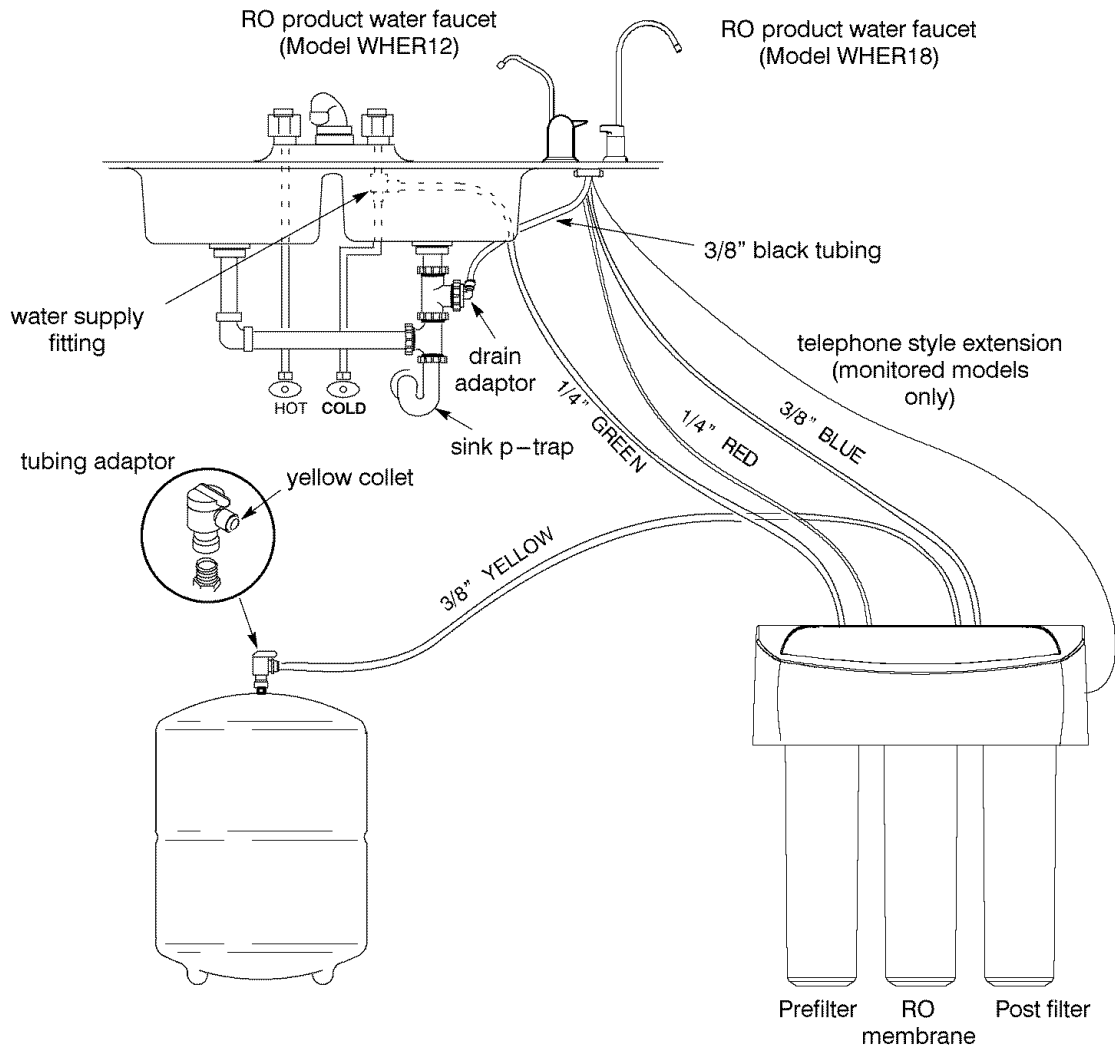

Figure 9
Sanitize, Pressure Test & Purge

Sanitize:

NOTE: Sanitizing is recommended upon installation of the RO system, and after servicing inner parts. It is important for the service person to have clean hands while handling inner parts of the system.

IMPORTANT: Be sure to remove the RO membrane and both filter cartridges as follows, before sanitizing. Chlorine will destroy the RO membrane cartridge.

1. Be sure the water supply to the RO is turned off, and the RO faucet is open to relieve pressure.
2. Remove the RO membrane sump by twisting 1/4 turn left (↺). Remove the RO cartridge from sump. Place the cartridge in a clean plastic bag.
3. Be sure the o-ring seal is on the sump. Replace the RO sump by turning to the right (↻) to lock.
4. Remove the postfilter sump, turning to the left. Take the cartridge from the sump and place in the plastic bag. Replace the sump by turning to the right (↻) to lock.
5. Remove the prefilter sump and cartridge. Also place this cartridge in the clean bag.



-
6. Flush the prefilter sump with fresh water, if needed to clean. Next, fill with water to about 1” from the top. Add 2 tablespoons of household bleach to water in sump. Do not add chlorine first. Concentrated, chlorine could attack plastics.

NOTE: Add bleach to water in sump to avoid plastic damage.

7. Carefully replace the sump in the prefilter location and turn to the right (↻) to lock.
8. Slowly open the water supply to the RO.
9. Open the RO faucet.
10. Allow water to circulate through the RO system until you smell the bleach odor at the faucet. Then close the faucet and allow the RO to stand idle for 20 minutes.
11. After the 20 minutes open the RO faucet and run water until the bleach odor is gone.
12. Turn off the water supply to the RO.
13. Reinstall the pre filter, post filter and RO cartridge that were removed in steps 1-5.

IMPORTANT: Refer to Figure 10, for proper o-ring orientation, when replacing cartridges.

Leak test:

NOTE: The sanitizing procedures must be done before leak test.

1. Open the water supply shutoff valve to the RO that was closed during sanitization, step 1.
2. Open the main water supply valve and several house faucets to purge air from the system. Close faucets when water runs smooth.
3. In about 2 hours, pressure will start to build in the RO system. Then, carefully check all fittings and connections for water leaks. Correct leaks if any are found.

NOTE: When the system is first pressurized, water may “spurt” from the faucet airgap hole in the back of the faucet until air is expelled from the RO system.

Purge RO membrane:

IMPORTANT: The RO cartridge contains a food grade preservative that should be removed before using water from the system by following the steps below. The preservative will give product water an unpleasant taste and odor.

NOTE: Do not remove blue wrapper from R.O. membrane. This will destroy the membrane.

1. Allow the storage tank to fill for about 4 hours. Then open the RO faucet until the tank is empty and flow stops. Close the RO faucet.

Repeat step 1 to purge the storage tank 6 times. Then the RO system is ready to make product water for use.

Routine Maintenance

To keep your reverse osmosis system operating and producing high quality water, you must make sure supply water is always within the limits shown in the specifications. Good supply water helps to assure longer life from the RO membrane cartridge, prefilter and postfilter cartridges. However, each of these will wear out in time and need replacement.

This reverse osmosis system contains a replaceable treatment component critical for effective removal of total dissolved solids. The monitor faucet feature provides continuous analysis of the systems performance. For systems not equipped with the monitor faucet function, have your water tested at least every 6 months to verify your system is performing properly. TDS test kits are available by calling 1-800-826-8553 ext. 47, or check the water testing section of your local phone directory.

If the RO assembly is wall mounted, you may be able to replace parts with the assembly left on the wall. If not, simply lift the RO assembly from the mounting washers and lay on the cabinet floor when replacing the prefilter and post filter cartridges and RO membrane.

NOTE: To prevent spillage, place a container under the RO assembly, or put the RO assembly in a container to catch the water.

IMPORTANT: Before disconnecting parts, be sure to close the water supply valve to the RO and close storage tank valve.

Prefilter and Post Filter Cartridges:

Filter life varies depending on local water conditions and the volume of water used. We recommend you change your filters every 6 months. However, they can be replaced earlier if there is a drop in pressure at the faucet.

To replace the filter cartridges:

1. Turn off the water supply and open the RO faucet to relieve pressure.
2. Remove (turn to the left) both sumps from the filter heads. Be careful . . .the sumps are full of water.
3. Remove and discard the inner cartridges in a proper manner. Flush the insides of the sumps with fresh water. Do not lose the large o-ring seals.
4. Insert new cartridges with o-ring seals towards the top, and with lubricated o-rings in place, turn to the right to reattach the sumps.

NOTE: Use a food grade lubricant or petroleum jelly.

5. Remove and replace batteries to reset counter and timer (monitor models).

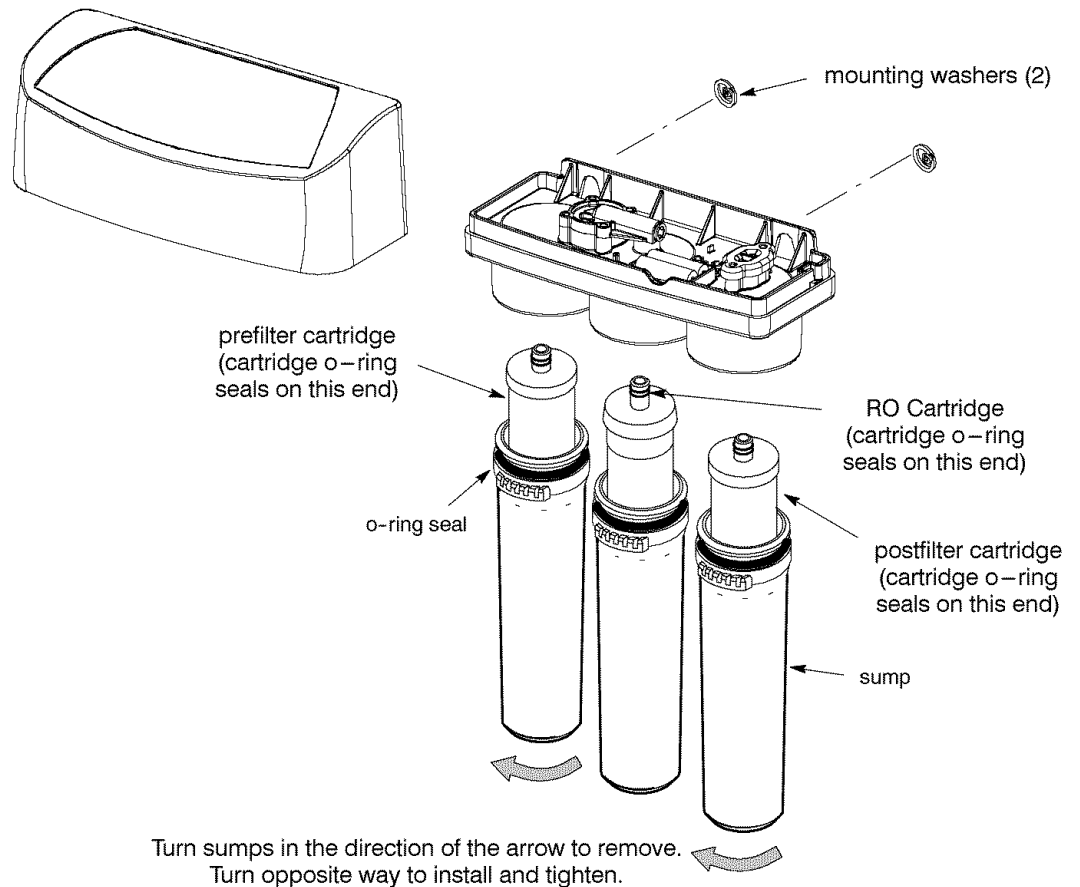

Figure 10
RO Membrane Cartridge

The life of the RO membrane cartridge can be maximized by a water softener on the incoming water supply and performing regular filter changes. See “Prefilters and Post Filters” section.

It’s time to replace the RO cartridge when the red LED flashes or the production rate and/or quality of product water drops. Product water may begin to taste different or bad, indicating solids and organics are passing through the RO membrane. To be sure it is the RO cartridge, replace the prefilter and post-filter cartridges first.

To replace the RO cartridge:

1. Turn off the water supply and open the RO faucet to relieve pressure.
2. Remove the sump from the filter head. Be careful . . .the sump is full of water.
3. Remove and discard the RO cartridge in a proper manner. Flush the insides of the sump with fresh water. Do not lose the large o-ring seals.

NOTE: Sanitizing is recommended after servicing inner parts of the system. See “Sanitize, Pressure Test & Purge” section.

4. Insert new RO cartridges with o-ring seals towards the top, and with lubricated o-ring in place, turn to the right to reattach the sump.
5. Remove and replace batteries to reset counter and timer (monitor models).
6. Purge the RO membrane cartridge. See “Sanitize, Pressure Test & Purge” section.

Flow Control

The flow control is vital for proper operation of the RO membrane cartridge. The control keeps water flow through the membrane at the needed rate to obtain the best quality product water.

Periodically check the flow control to be sure the small hole through it is clean and unrestricted.

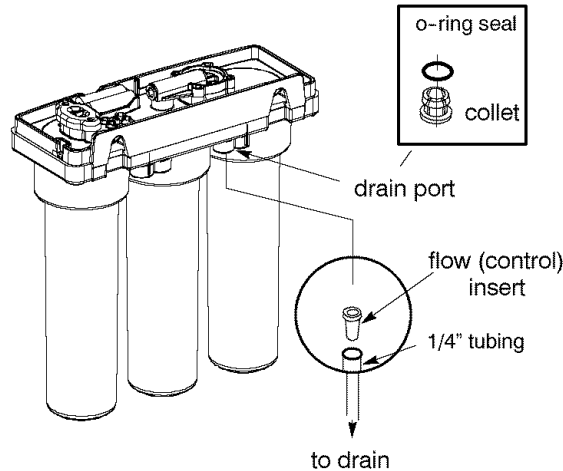

Figure 11

Tubing Connection (all push-in fitting locations)

This RO system includes push-in fittings for quick tubing connection. If working with the fittings, do the following.

Connect Tubing:

1. Use a utility knife to cut the end of tubing square.
2. Inspect the end (about 1") of the tubing to be sure there are no nicks, scratches or other rough spots. If needed, cut the tubing again.
3. Push tubing through the collet and all the way into fitting. Full engagement is 11/16" for 1/4" tubing, and 3/4" for 3/8" tubing.

If using tubing other than tubing supplied with the system, be sure it is of high quality, exact size and roundness with a smooth surface.

To Disconnect Tubing:

1. Push the collet inward and hold with a finger while pulling the tubing out.

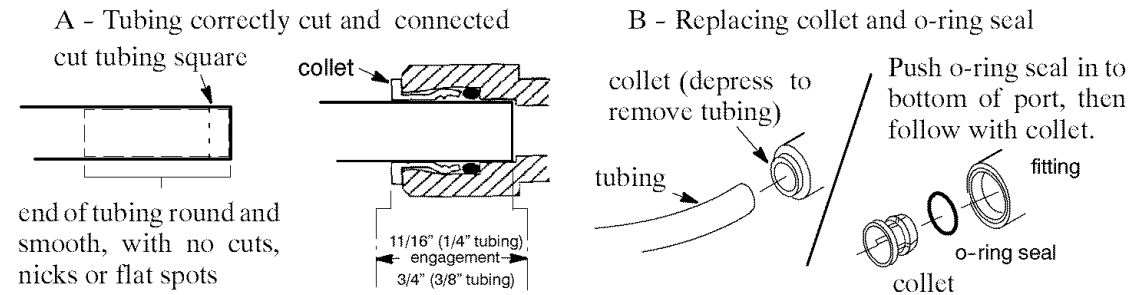

Figure 12

Changing Collet and O-ring:

1. With a small screwdriver remove the collet and o-ring from the fitting. Be careful not to scratch the internal walls of the collet port.
2. Be sure the port is clean, then lubricate and insert the o-ring seal to the bottom of the port.
3. Push the collet inward until it locks in place.

IMPORTANT: using vinegar or other acid based cleaners on this RO system can degrade some RO system parts. Use only soap and water for cleaning.

NOTE: This reverse osmosis system contains a replaceable component critical to the efficiency of the system. Replacement of the reverse osmosis component should be with one of identical specifications, as defined by the manufacturer, to assure the same efficiency and contaminant reduction performance.

Automatic Shutoff

If the shutoff assembly requires service, be sure to reassemble parts exactly as shown in Figure 13.

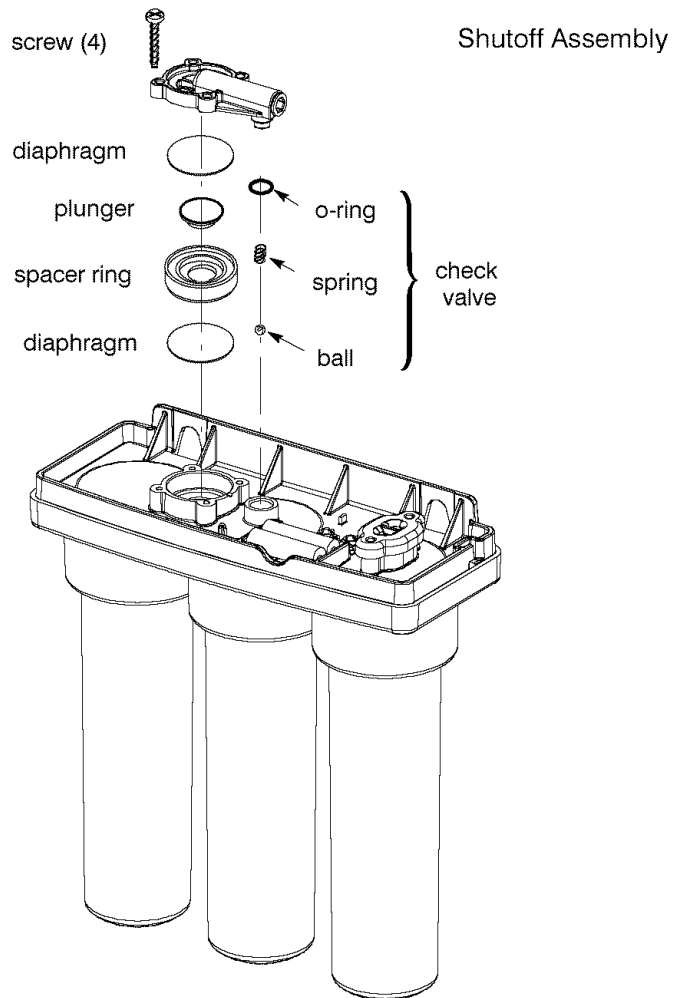

Figure 13

Troubleshooting Guide

REVERSE OSMOSIS SYSTEM CARE GUIDE MODEL NOS. WHER12 and WHER18

1. AT LEAST every 6 months, replace the prefilter and postfilter cartridges or when yellow LED flashes.
 2. Replace the RO membrane cartridge when the percent rejection of total dissolved solids (TDS) is less than shown in the specifications (see B, below) or when red LED flashes.
 3. Replace the batteries once per year.
- If any of the following occur before the 6 months, replace as directed.
- A. Slow Making of Product Water: Replace the prefilter cartridge. If the production rate does not improve, replace the post filter cartridge and RO membrane cartridge.
- B. High Total Dissolved Solids (TDS) in Product Water: Send treated and untreated water samples to a water analysis lab for testing. It is important to test both the treated and untreated water to determine system performance. If the TDS is not within the system's performance guidelines, replace the prefilter, post filter and RO membrane cartridges.
- C. Chlorine Taste and/or Odor: Replace the prefilter, post filter and RO membrane cartridges.

OTHER TROUBLESHOOTING

PROBLEM	CAUSE	CORRECTION
Chlorine taste and/or odor in the RO product water	The ppm of chlorine in your water supply exceeds maximum limits, and has destroyed the RO membrane.	If the water supply contains more than 2.0 ppm of chlorine, additional filtering of the water supply to the RO is needed. Correct this condition before doing maintenance on the RO system.
	The prefilter is no longer removing chlorine from the water supply.	Replace the prefilter, post filter and RO membrane cartridges.
Other taste and/or odor	Post filter expended.	Replace the post filter cartridge. If taste and odor persists, replace the prefilter cartridge and RO membrane cartridge.
	RO membrane cartridge expended.	
	Contamination in product water storage.	Use sanitizing procedures. Replace the post filter cartridge.
System makes product water too slowly	Water supply to the RO system not within specifications.	Check water pressure, if below listed requirement, contact a licensed plumber. Precondition the water, etc., as needed to conform, before doing maintenance on the RO system.
	Prefilter or RO membrane cartridges plugged with sediments.	Replace the prefilter cartridge. If rate does not increase, replace the postfilter cartridge and RO membrane cartridge.
System delivers lower amount of product water than usual	Storage tank air-charge less than 5 – 7 psi when tank is empty.	Open RO faucet and drain tank until flow slows to a drip. Keep faucet open and check tank pressure. If low, pressurize to 6 psi. Close faucet to refill the tank.
High total dissolved solids (TDS) in product water – flashing red LED	Water supply to the RO system not within specifications.	Increase water pressure, precondition the water, etc., as needed to conform before doing maintenance on the RO system.
	RO membrane cartridge expended.	Replace the prefilter, postfilter and RO membrane cartridges, flow control, and screen.
Water leaking from faucet airgap hole	Drain side of faucet airgap (3/8" tubing) plugged, restricted, or incorrectly connected to drain point.	Inspect and eliminate restriction or plug. Refer to installation instructions for proper drain connection.
Continual water flow to drain	Check valve or automatic shutoff assembly plugged, restricted or parts worn	Clean, repair or replace as needed.
Faucet LED indicator light does not function after battery change	Batteries dead.	Replace with new batteries.
	Batteries installed incorrectly.	Install batteries correctly.
	Static protection device was not discharged.	Remove batteries for a minimum of one hour and then reinstall.
Continual water flow to drain and no product water	Missing flow restrictor in red drain tube or its corresponding port.	Replace flow restrictor.
	Check ball assembly not seating.	Clean or replace check ball assembly.

NOTE: Sanitizing is recommended after servicing inner parts of the system. See “Sanitize, Pressure Test and Purge” section.

Specifications

Water Specifications	WHER12	WHER18	Metric
Supply water pressure limits	40 – 100 psi	40 – 100 psi	280 – 690 kPa
Supply water temperature limits	40 – 100 °F	40 – 100 °F	5 – 40°C
Maximum total dissolved solids (TDS)	2000 ppm	2000 ppm	–
Maximum water hardness ②	10 gpg	10 gpg	–
Maximum iron, manganese, hydrogen sulfide	0	0	–
Chlorine in water supply (max. ppm)	2.0	2.0	–
Supply water pH limits (pH)	4 – 10	4 – 10	–
Product (quality) water, 24 hours ①	14 gallons	22 gallons	53 liters/ 83 liters

Product Specifications	WHER12	WHER18	Metric
Percent rejection of TDS, minimum (new membrane) ①	90 – 95	90 – 95	–
Storage tank capacity (max.)	2.3 gallons	2.3 gallons	8.7 liters
Automatic shutoff control	yes	yes	–
TDS Monitor	no	yes	–
Filter Change Monitor	no	yes	–
Efficiency ③	8%	10%	–
Recovery ④	16%	18%	–

These systems conform to NSF/ANSI 58 for the specific performance claims as verified and substantiated by test data.

① feed water supply at 50 psi, 77°F, and 750 TDS - Quality water production, amount of waste water and percent rejection all vary with changes in pressure, temperature and total dissolved solids.

② For water with hardness greater than 10 grains the use of a softener is recommended.

③ Efficiency rating means the percentage of the influent water to the system that is available to the user as reverse osmosis treated water under operating conditions that approximate typical daily use.

④ Recovery rating means the percentage of the influent water to the membrane portion of the system that is available to the user as reverse osmosis treated water when the system is operated without a storage tank or when the storage tank is bypassed.

Repair Parts

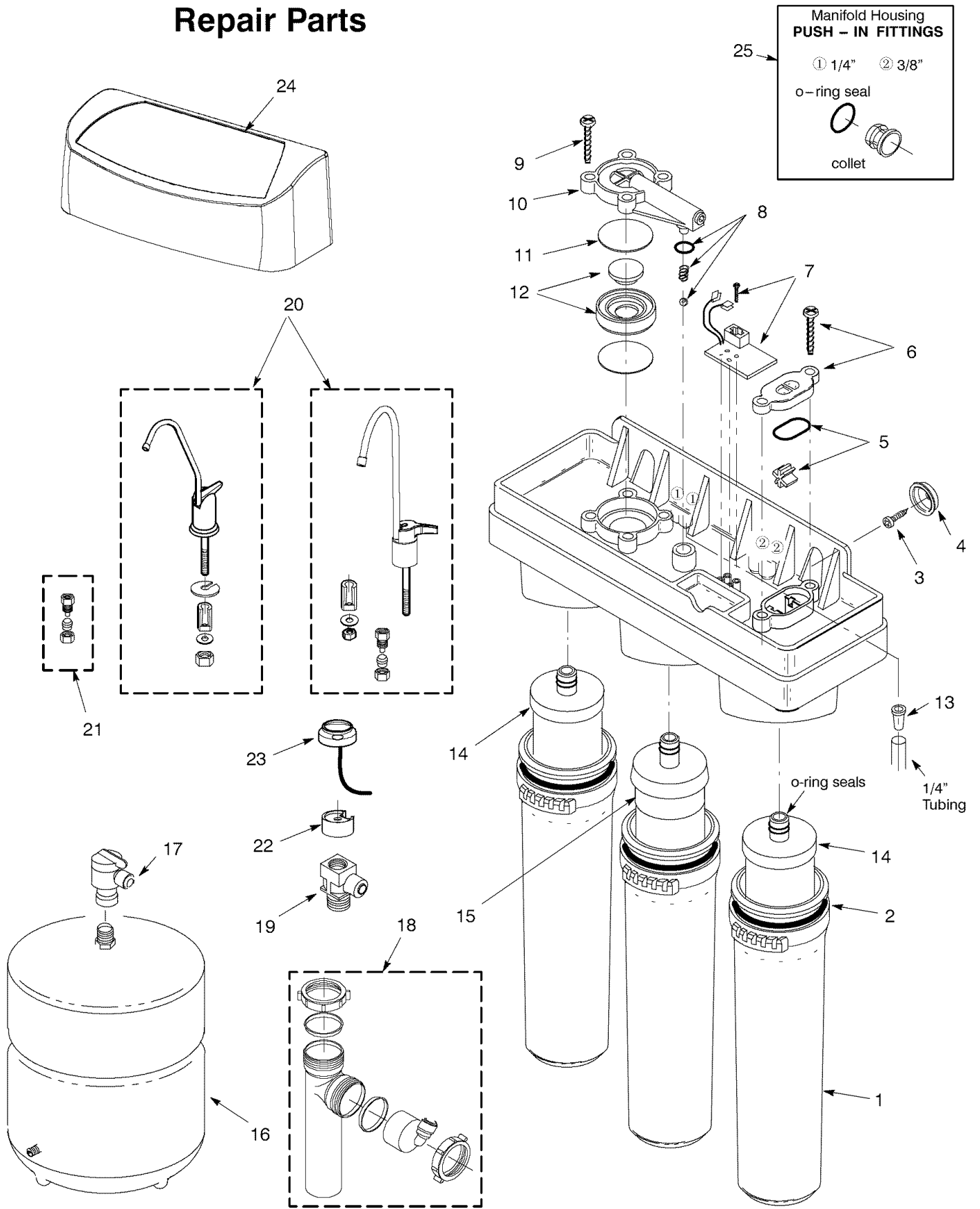

Repair Parts

Key No.	Part No.	Description
1	7221128	Sump (3 req.)
2	7223633	O-Ring, 2-1/4" x 2-1/2" (3 req.)
3	9006062	Screw (2 req.)
4	9041700	Hanger Washer (2 req.)
5	7234210	Paddlewheel & O-Ring Kit, Model WHER18 only
6	7234228	Paddlewheel Cover (includes screws), Model WHER18 only
7	7234294	Pwa (includes screw), Model WHER18 only
8	7234317	Check Ball Assembly
9	7229451	Screw (4 req.)
10	7229532	Automatic Shut-off Cover
11	7250876	Diaphragm Kit
12	7234325	Plunger & Spacer Ring Kit
■	7095030	Cone Screen
13	7265766	Flow (Control) Insert, Model WHER12
	7199486	Flow (Control) Insert, Model WHER18
14	WHERF	Filter, Carbon Block (2 req.)
15	7264223	RO Membrane Cartridge, Model WHER12
	7266186	RO Membrane Cartridge, Model WHER18

Key No.	Part No.	Description
16	7205326	Storage Tank
17	7251034	Connector, 1/4 NPT x 3/8 Tube
18	7208489	Drain Adapter
19	7227310	Tee, Feed Adaptor
20	7271319	Faucet, Model WHER12
	7263895	Faucet, Model WHER18
21	7235965	Tubing Adaptor, Model WHER12 only
22	7267124	Spacer, Model WHER18
23	7264841	Rep'l Electronics Ring, Model WHER18
24	7262564	Cover, order decal below
	7263968	Decal, Cover
25	7209566	Push-in Fitting Kit, 1/4" X ●
	7209574	Push-in Fitting Kit, 3/8" ✓ ●
■	7161823	Tubing, 1/4" x 20' - white ☐ ●
■	7161784	Tubing, 1/4" x 100' - white ☐ ●
■	7157280	Tubing, 3/8" x 20' - white ☐ ●
■	7161750	Tubing, 3/8" x 100' - white ☐ ●

☐ tubing lengths for remote installations, direct replacement for colored lengths of tubing.

X ✓ Note: This o-ring and collet are for replacement in the manifold housing only. They do not fit the other push-in fittings, key nos. 17, 18, 20, 21 and 22.

● not included

■ not illustrated

To order repair parts call toll free 1-866-986-3223, Monday - Friday, 8 am - 9 pm EST.

Manufactured and warranted by
Ecodyne Water Systems, Inc.
1890 Woodlane Drive
Woodbury, MN 55125

Product Schematic

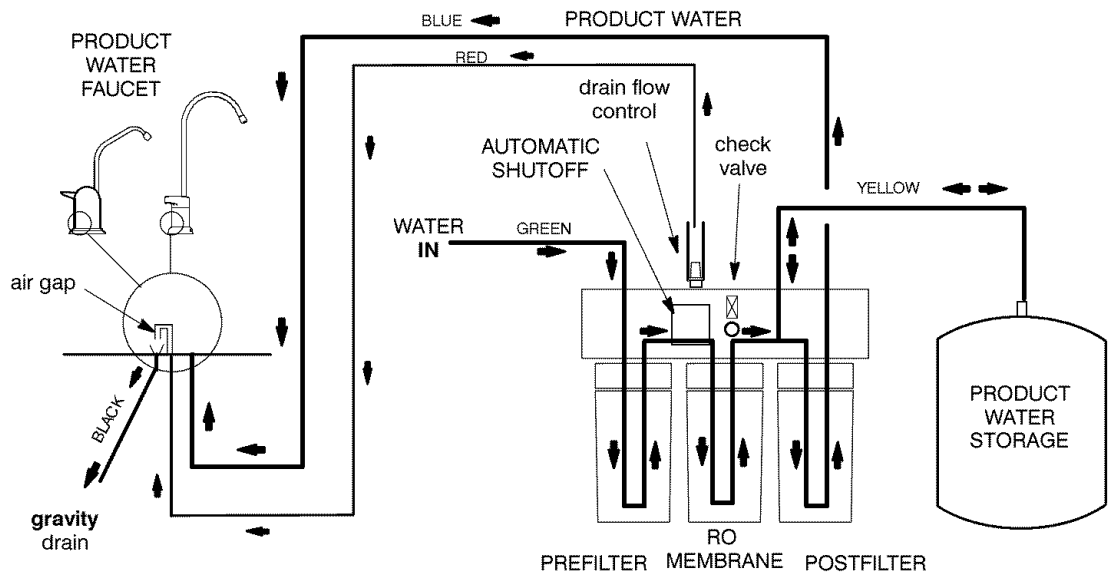

Figure 14

Warranty

ONE YEAR LIMITED WARRANTY ON REVERSE OSMOSIS DRINKING WATER SYSTEM (except filter cartridges and R. O. membrane)

Warrantor: Ecodyne Water Systems Inc., 1890 Woodlane Drive, Woodbury, MN 55125

Warrantor guarantees, to the original owner, that the Reverse Osmosis Drinking Water System, when installed and maintained in accordance with the instructions, will be free from defects in materials and workmanship for a period of one year from date of installation.

If, within the first year, a part proves, after inspection, to be defective, Warrantor will, at its sole option, either replace or repair the part without charge except normal shipping and installation charges. Labor to maintain the equipment is not part of the warranty. Filters and membranes, which are expendable, are not covered by the warranty.

TO OBTAIN WARRANTY PARTS, SIMPLY CALL 1-866-986-3223, Monday - Friday, 8 am - 9 pm EST, for assistance. This warranty applies only while this product is in use in the United States.

General Provisions

The above warranties are effective provided the Reverse Osmosis Drinking Water System is operated at water pressures not exceeding 100 psi, and at water temperatures not exceeding 100°F; provided further that the Reverse Osmosis Drinking Water System is not subject to abuse, misuse, alteration, neglect, freezing, accident or negligence; and provided further that the Reverse Osmosis Drinking Water System is not damaged as the result of any unusual force of nature such as, but not limited to, flood, hurricane, tornado or earthquake.

Warrantor is excused if failure to perform its warranty obligations is the result of strikes, government regulation, materials shortages, or other circumstances beyond its control.

*THERE ARE NO WARRANTIES ON THE REVERSE OSMOSIS DRINKING WATER SYSTEM BEYOND THOSE SPECIFICALLY DESCRIBED ABOVE. ALL IMPLIED WARRANTIES, INCLUDING ANY IMPLIED WARRANTY OF MERCHANTABILITY OR OF FITNESS FOR A PARTICULAR PURPOSE, ARE DISCLAIMED TO THE EXTENT THEY MIGHT EXTEND BEYOND THE ABOVE PERIODS. THE SOLE OBLIGATION OF WARRANTOR UNDER THESE WARRANTIES IS TO REPLACE OR REPAIR THE COMPONENT OR PART WHICH PROVES TO BE DEFECTIVE WITHIN THE SPECIFIED TIME PERIOD, AND WARRANTOR IS NOT LIABLE FOR CONSEQUENTIAL OR INCIDENTAL DAMAGES. NO WARRANTOR DEALER, AGENT, REPRESENTATIVE, OR OTHER PERSON IS AUTHORIZED TO EXTEND OR EXPAND THE WARRANTIES EXPRESSLY DESCRIBED ABOVE.

Some states do not allow limitations on how long an implied warranty lasts or exclusions or limitations of incidental or consequential damage, so the limitations and exclusions in this warranty may not apply to you. This warranty gives you specific legal rights, and you may have other rights which vary from state to state. This warranty applies to consumer-owned installations only.

® Registered trademark/TM Trademark of Whirlpool, USA, used under license.

© 2004 Whirlpool Corporation. All rights reserved.