

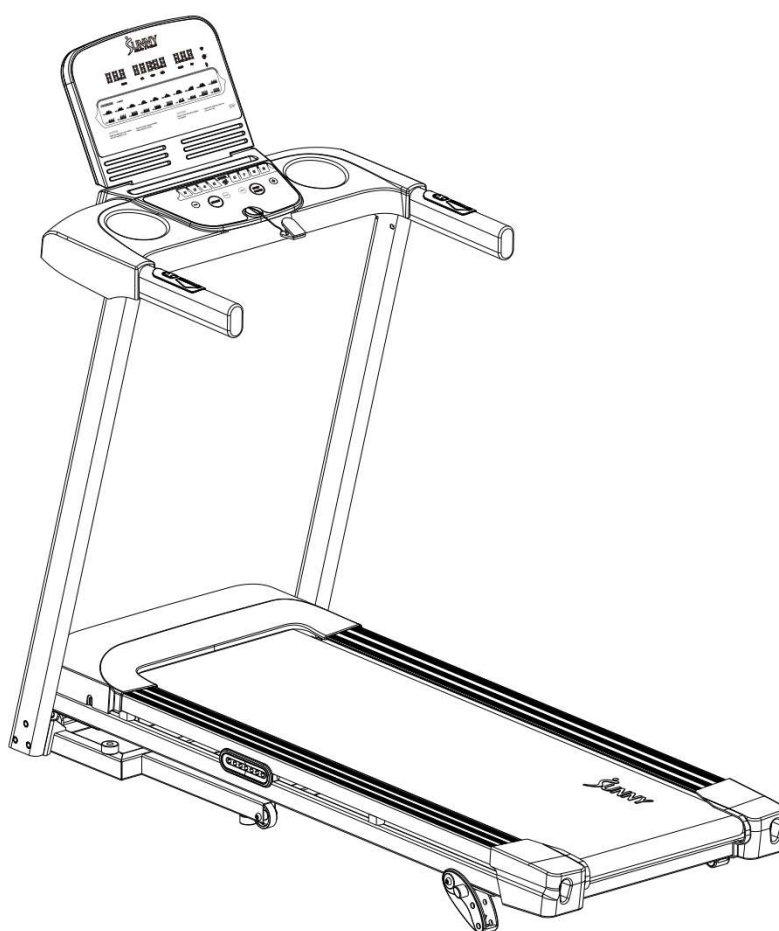

User Manual



APEX 300TL Treadmill

SF-T724811

EN

IMPORTANT! Please retain owner's manual for maintenance and adjustment instructions. Your satisfaction is very important to us, **PLEASE DO NOT RETURN UNTIL YOU HAVE CONTACTED US.**

Important Safety Information

We thank you for choosing our product. To ensure your safety and health, please use this equipment correctly. It is important to read this entire manual before assembling and using the equipment. Safe and effective use can only be achieved if the equipment is assembled, maintained, and used properly. It is your responsibility to ensure that all users of the equipment are informed of all warnings and precautions.

1. Before starting any exercise program, you should consult your physician to determine if you have any medical or physical condition that could put your health and safety at risk or prevent you from using the equipment properly. Your physician's advice is essential if you are taking medication that affects your heart rate, blood pressure or cholesterol level.
2. Be aware of your body's signals. Incorrect or excessive exercise can damage your health. Stop exercising if you experience any of the following symptoms: pain, tightness in your chest, irregular heartbeat, shortness of breath, lightheadedness, dizziness, or feelings of nausea. If you do experience any of these conditions, you should consult your physician before continuing with your exercise program.
3. Keep children and pets away from the equipment.
4. Use the equipment on a solid, flat level surface with a protective cover for your floor or carpet. To ensure safety, the equipment should have at least 8 feet (240 cm) of free space behind it and 2 feet (60 cm) on each side. Do not place the treadmill on any surface that blocks air openings. To protect the floor or carpet from damage, place a mat under the treadmill.
5. Ensure that all nuts and bolts are securely tightened before using the equipment. The safety of the equipment can only be maintained if it is regularly examined for damage and/or wear and tear.
6. Always use the equipment as indicated. If you find any defective components while assembling or checking the equipment, or if you hear any unusual noises coming from the equipment during exercise, discontinue use of the equipment immediately and do not use until the problem has been rectified.
7. Wear suitable clothing while using the equipment. Avoid wearing loose clothing that may become entangled in the equipment.
8. Do not place fingers or objects into the moving parts of the equipment.
9. The maximum weight capacity of this unit is 300 lbs (135 kg).
10. The equipment is not suitable for therapeutic use.
11. To avoid bodily injury and/or damage to the product or property, proper lifting and moving are required.
12. Your product is intended for use in cool and dry conditions. You should avoid storage in extremely cold, hot or damp areas as this may lead to corrosion and other related problems.
13. This equipment is designed for indoor and home use only; it is not intended for commercial use.

⚠ IMPORTANT NOTE: The running belt must be lubricated before the first use! Please see Page 11 for instructions on how to properly apply lubricant.

Important Safety Instructions

When using an electrical appliance, basic precautions should always be followed, including the following:

Read all instructions before using (this appliance).

DANGER – To reduce the risk of electric shock and the injury from moving parts:

Always unplug this appliance from the electrical outlet immediately after using and before cleaning or servicing.

WARNING – To reduce the risk of burns, fire, electric shock, or injury to persons:

1. An appliance should never be left unattended when plugged in. Unplug from outlet when not in use, and before putting on or taking off parts.
2. This appliance is not intended for use by persons with reduced physical, sensory, or mental capabilities, or lack of experience and knowledge, unless they have been given supervision or instruction concerning use of the appliance by a person responsible for their safety. Keep children under the age of 13 away from this machine.
3. Use this appliance only for its intended use as described in this manual. Do not use attachments not recommended by the manufacturer.
4. Never operate this appliance if it has a damaged cord or plug, if it is not working properly, if it has been dropped or damaged, or dropped into water. Please contact Customer Service at support@sunnyhealthfitness.com.
5. Do not carry this appliance by supply cord or use cord as a handle.
6. Keep the cord away from heated surfaces.
7. Never operate the appliance with the air openings blocked. Keep the air openings free of lint, hair, and the like.
8. Never drop or insert any object into any opening.
9. Do not use outdoors. Household use only.
10. Do not operate where aerosol (spray) products are being used or where oxygen is being administered.
11. To disconnect, turn all controls to the off position, then remove plug from outlet.
12. CAUTION: Risk of Injury to Persons – To Avoid Injury, use extreme caution when stepping onto or off of a moving belt. Read Instruction Manual Before Using.
13. Connect this appliance to a properly grounded outlet only. See Grounding Instructions.
14. Remove control box (or key, or safety pin, as applicable) when not in use, and store out of reach of children.

SAVE THESE INSTRUCTIONS

CAUTION: The user is cautioned that changes or modifications not expressly approved by the party responsible for compliance could void the user's authority to operate the equipment. This device contains license-exempt transmitter(s)/receiver(s) that comply with Innovation, Science and Economic Development Canada's license-exempt RSS(s) and Part 15 of the FCC Rules. Operation is subject to the following two conditions:

- 1) This device may not cause interference.
- 2) This device must accept any interference, including interference that may cause undesired operation of the device.

NOTE: This equipment has been tested and found to comply with the limits for a Class B digital device, pursuant to Part 15 of the FCC Rules. These limits are designed to provide reasonable protection against harmful interference in a residential installation. This equipment generates, uses, and can radiate radio frequency energy and, if not installed and used in accordance with the instructions, may cause harmful interference to radio communications. However, there is no guarantee that interference will not occur in a particular installation.

If this equipment does cause harmful interference to radio or television reception, which can be determined by turning the equipment off and on, the user is encouraged to try to correct the interference by one or more of the following measures:

- Reorient or relocate the receiving antenna.
- Increase the separation between the equipment and receiver.
- Connect the equipment into an outlet on a circuit different from that to which the receiver is connected.
- Consult the dealer or an experienced radio/TV technician for help.

FCC Radiation Exposure Statement

This equipment complies with FCC radiation exposure limits set forth for an uncontrolled environment. This equipment should be installed and operated with a minimum distance of 20cm between the radiator and your body.

This transmitter must not be co-located or operating in conjunction with any other antenna or transmitter.

Important Electrical Information

IMPORTANT NOTE:

This treadmill requires a power source of 120 Volts in order to properly operate. For your safety, as well as the safety of others, please verify that the power source is correct before powering the equipment. Any power supply source above or below this level could cause significant damage to the equipment and/or user.

GROUNDING METHODS:

This product must be grounded. Should the treadmill malfunction or breakdown, grounding provides a path of least resistance for electric current to reduce the risk of electric shock. This product is equipped with a plug that has an equipment-grounding conductor and a grounding plug. The plug must be plugged into an appropriate outlet that is properly installed and grounded in accordance with all local codes and ordinances.

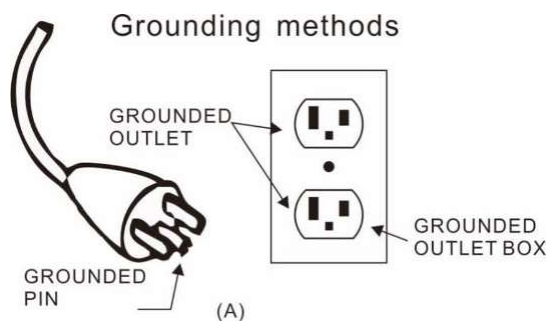

CAUTION:

Improper connection of the equipment can result in risk of electric shock. Check with a qualified electrician if you are unsure whether the product has been properly grounded. Do not modify the plug provided with this product. If it will not fit the outlet, have a proper outlet installed by a qualified electrician. Ensure that the product is connected to an outlet with the same configuration as the plug. Do not use an adaptor for this product.

WARNING!

1. **NEVER** use a ground fault circuit interrupt (GFCI) outlet with this treadmill. Route the power cord away from all moving parts of the treadmill, including the Air Pressure Cylinder and transportation wheels.
2. **NEVER** operate the treadmill using a generator or UPS power supply.
3. **NEVER** remove any cover on this treadmill without first disconnecting the power cord.
4. **NEVER** expose the treadmill to rain or moisture. This treadmill is not designed for outdoor use or use in any high humidity environment.

Statement of Purpose

The treadmill is a fitness machine designed to simulate walking, jogging, or running indoors. It provides a convenient and controlled environment for cardiovascular exercise, supporting a range of fitness levels and training goals.

Waste Disposal



Sunny Health & Fitness products are recyclable. At the end of its useful life please dispose of this article correctly and safely (local refuse sites).

EU Declaration of Conformity



You can find the declaration of conformity at the following link:
<https://sunnyhealthfitness.com/pages/declaration-of-conformity>

Technical Data

Connectivity: Bluetooth LE
Frequency Range: 2400~2483.5 Mhz
Transmitting Power: 0 dBm

Pre-Assembly Checklist

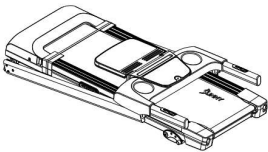
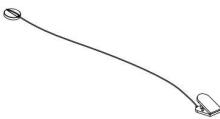
When you open the carton, you will find the following parts:

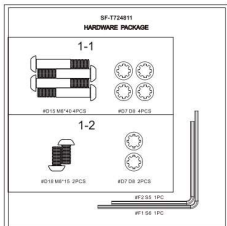
 A	 C19	 F3
		

Hardware Package

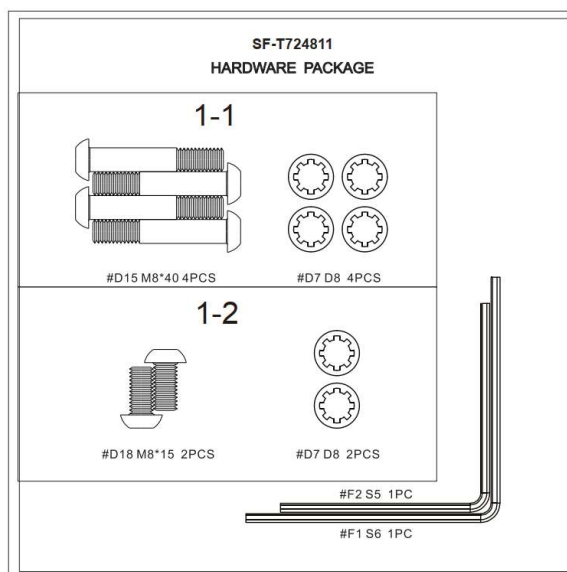

Ordering Replacement Parts

Please provide the following information in order for us to accurately identify the part(s) needed:

- ✓ The model number
- ✓ The product name
- ✓ The part number

Please contact us at support@sunnyhealthfitness.com or 1-877-90SUNNY (877-907-8669).

Warning Labels

⚠ WARNING		⚠ WARNING
In order to ensure safe use of the treadmill, please use the appropriate socket with the power cord.		In order to ensure safe use of the treadmill, please use the appropriate socket with the power cord.

**⚠ WARNING
AVERTISSEMENT**

Please read all warnings and instructions before using the machine.
Veuillez lire tous les avertissements et toutes les instructions avant d'utiliser les machines.

Risk of personal injury - Keep children under the age 13 and pets away from the machine.
Risques de blessures - Tenez les enfants de moins de 13 ans et les animaux domestiques à l'écart des machines.

Remove control box (or key, or safety pin, as applicable) when not in use, and store out of reach of children.
Retirez le boîtier de commande (ou la clé, ou la goupille de sécurité, selon le cas) lorsqu'il n'est pas utilisé, et rangez-le hors de portée des enfants.

To reduce the risk of electric shock - unplug before cleaning or servicing.
Pour réduire le risque d'électrocution, débranchez l'appareil avant de le nettoyer ou de l'entretenir.

300 LBS (135 KG) Weight Capacity
Capacité de charge de 300 LBS (135 KG)

Failure to comply with these warnings could result in serious injury or death.
Le non-respect de ces avertissements peut entraîner des blessures graves, voire mortelles.

Make sure all nuts and bolts are securely tightened before each use.
Assurez-vous que tous les écrous et les boulons sont bien serrés avant chaque utilisation.

**⚠ CAUTION
ATTENTION**

Risk of injury to persons: To avoid injury, use extreme caution when stepping onto or off of a moving belt. Read instruction manual before using.
Risque de blessure pour les personnes: Pour éviter les blessures, soyez extrêmement prudent lorsque vous montez ou descendez de la courroie mobile. Lisez le manuel d'utilisation avant de commencer l'utilisation.

To reduce risk of injury from moving parts, unplug before servicing.
Pour réduire le risque de blessures causées par des pièces mobiles, débranchez avant l'entretien.



NEVER PLACE FINGERS NEAR OR BETWEEN THE REAR END CAPS & REAR ROLLER.

NEVER STAND ON REAR END CAPS! PLEASE BE SURE TO ALWAYS WEAR SHOES WHEN USING EQUIPMENT.

RUNNING BELT ADJUSTMENT

LOOSEN TIGHTEN

TO ADJUST RUNNING BELT USE Allen WRENCH



Lubricant for Treadmill

Capacity: 20ML Used for 600 hours

Usage Method:
To apply lubricant, lift one side of the running belt and apply oil to the middle of the running board. Next, start the treadmill and place it at the lowest speed setting and allow the oil to spread over the running board.

Must be stored in a cool, dry area.

This lubricant is not intended for consumption. Eating is strictly prohibited.

ATTENTION

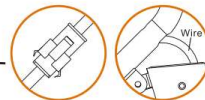

Please be careful not to pinch or puncture the wires when folding the treadmill.

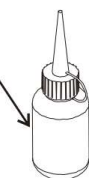

Use your foot to firmly push against the cylinder to release the folding mechanism.

⚠ CAUTION

KEEP HANDS AND FEET AWAY FROM THIS AREA WHILE THE TREADMILL IS RUNNING.

⚠ WARNING!
Do not remove the packing belt until the assembly is complete.

Do not lay the unit on its side!

- Open the carton to remove the equipment (A) and place the unit on the ground face up. For your safety, DO NOT remove the packing belt (B).
- After you've completed the assembly, you may remove the packing belt (B).

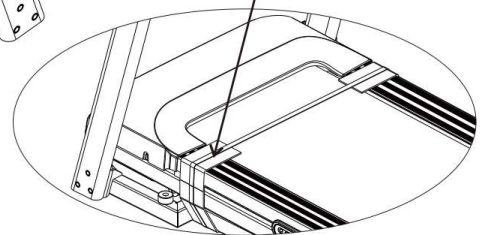

Assembly Instructions

We value your experience using Sunny Health and Fitness products. For assistance with parts or troubleshooting, please contact us at support@sunnyhealthfitness.com or 1-877-90SUNNY (877-907-8669).

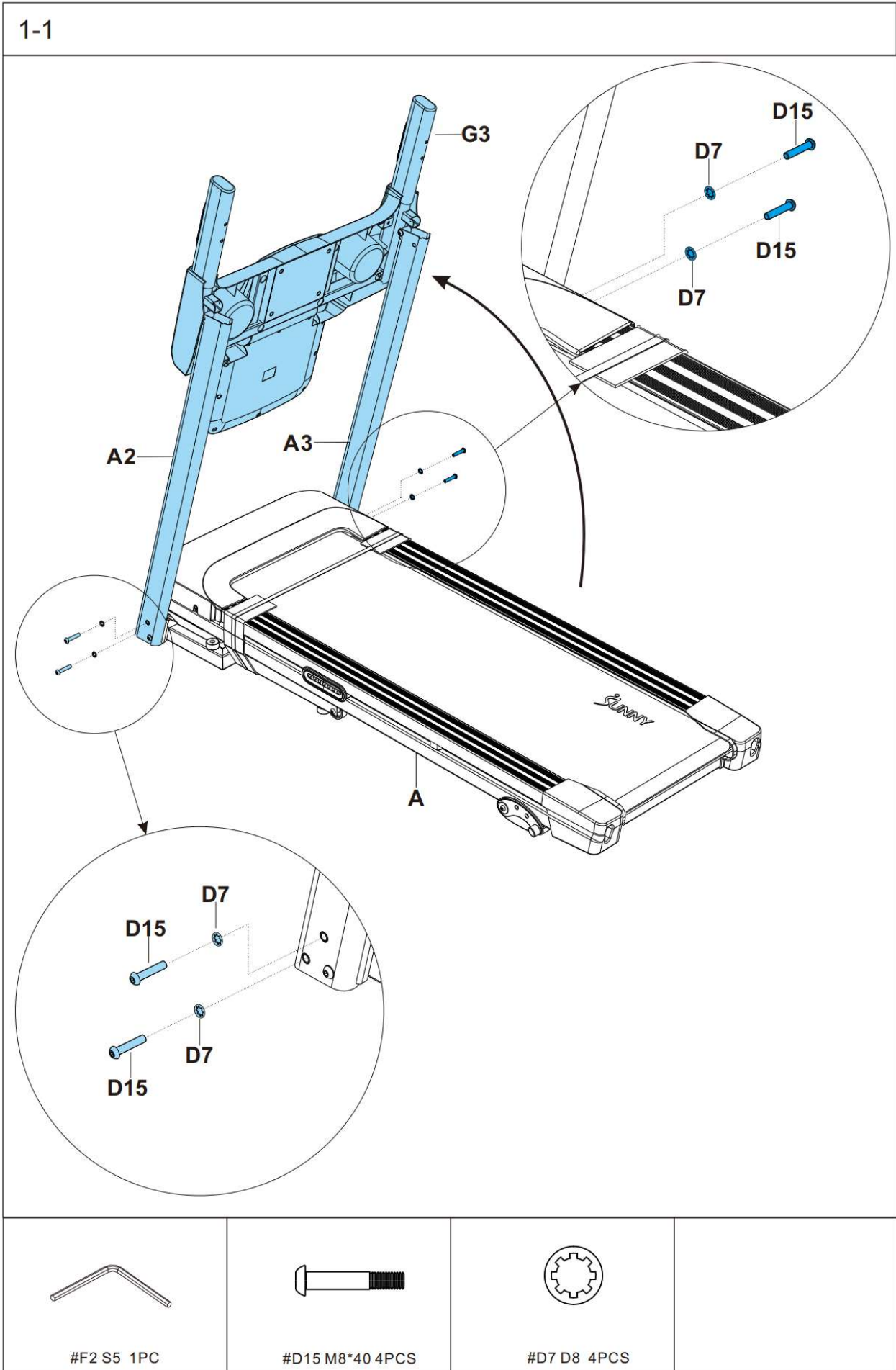

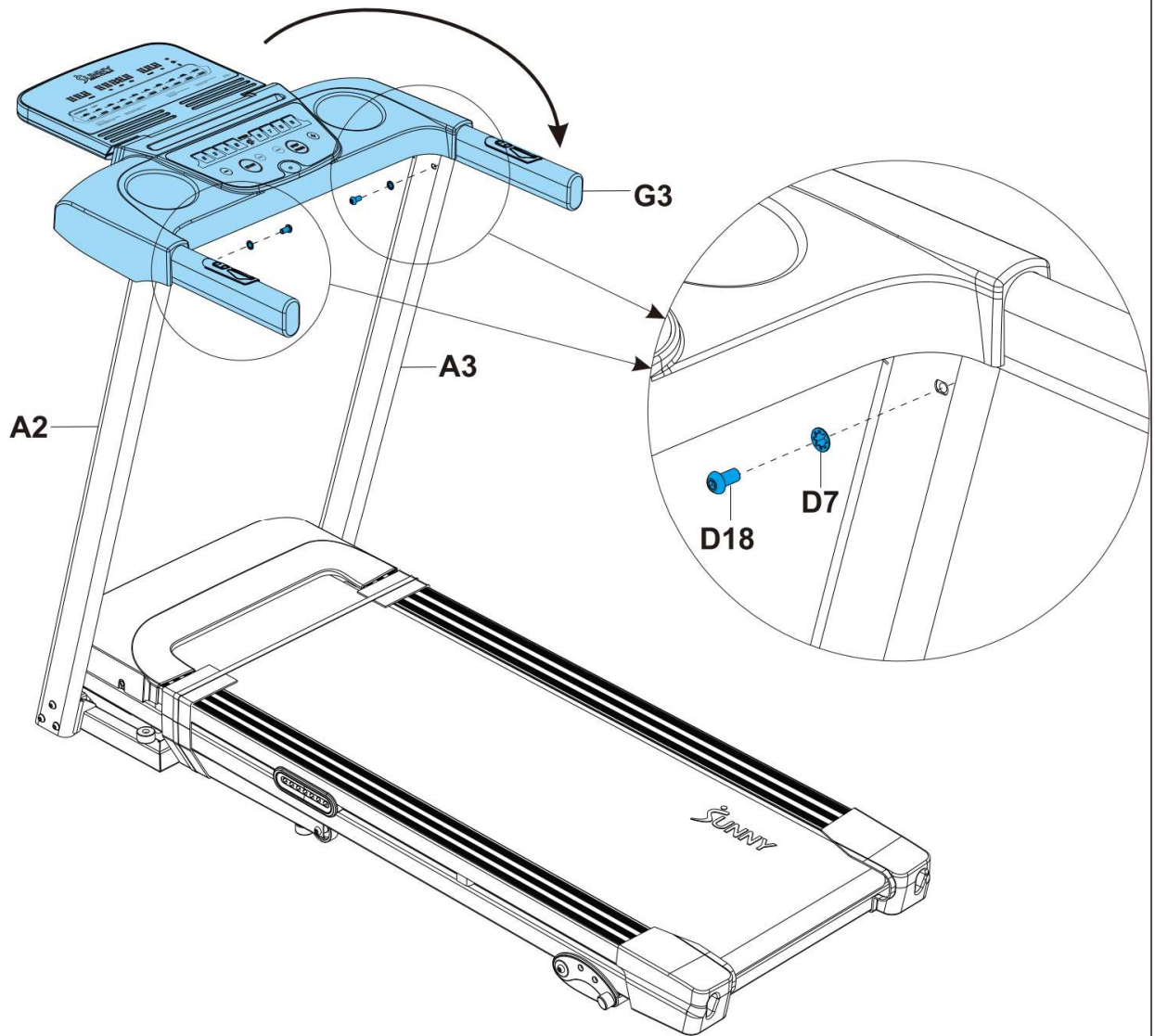

#F2 S5 1PC

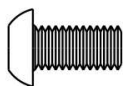

#D18 M8*15 2PCS



#D7 D8 2PCS

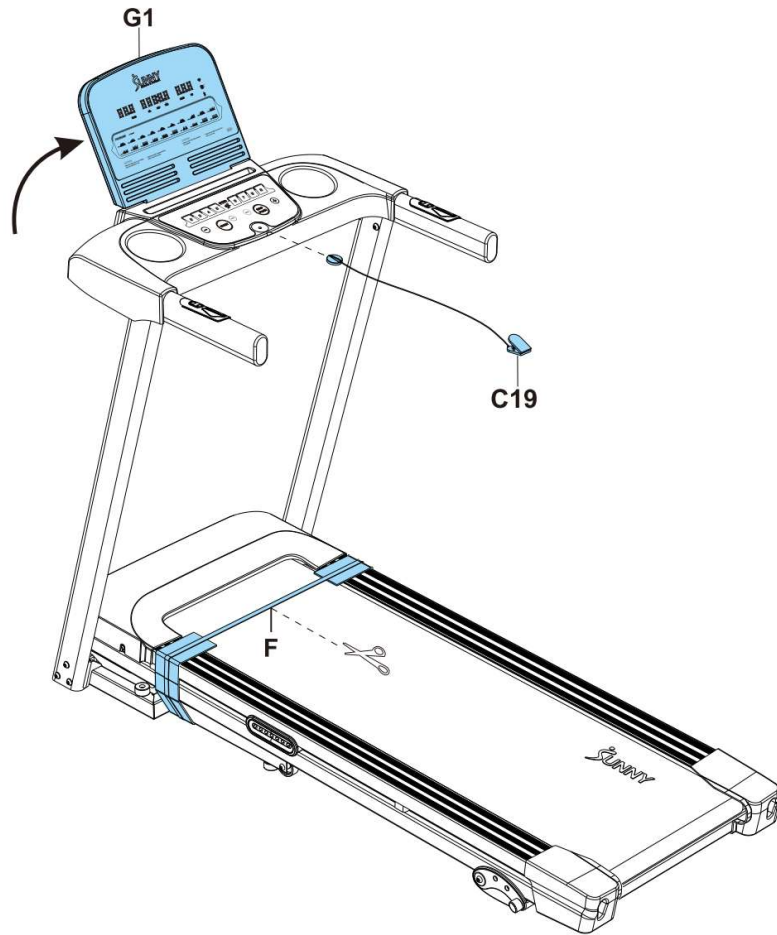

2-1

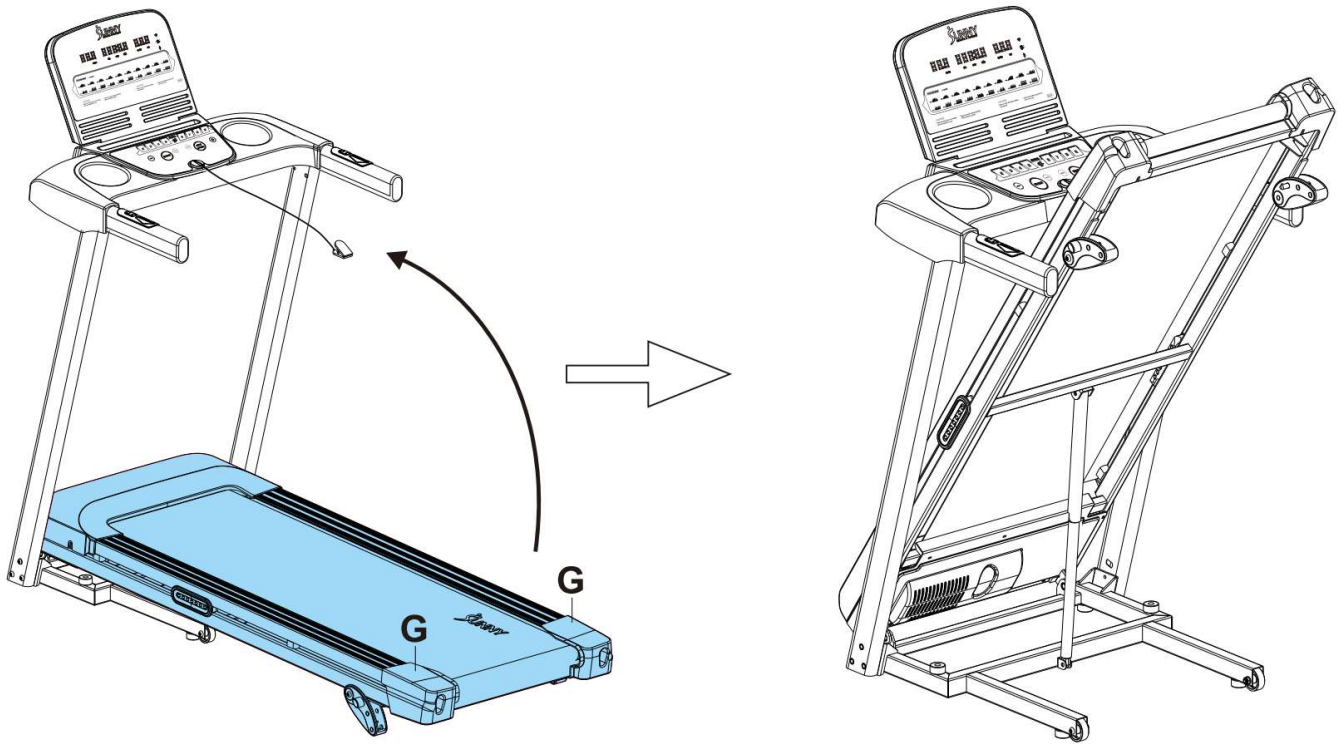

2-2

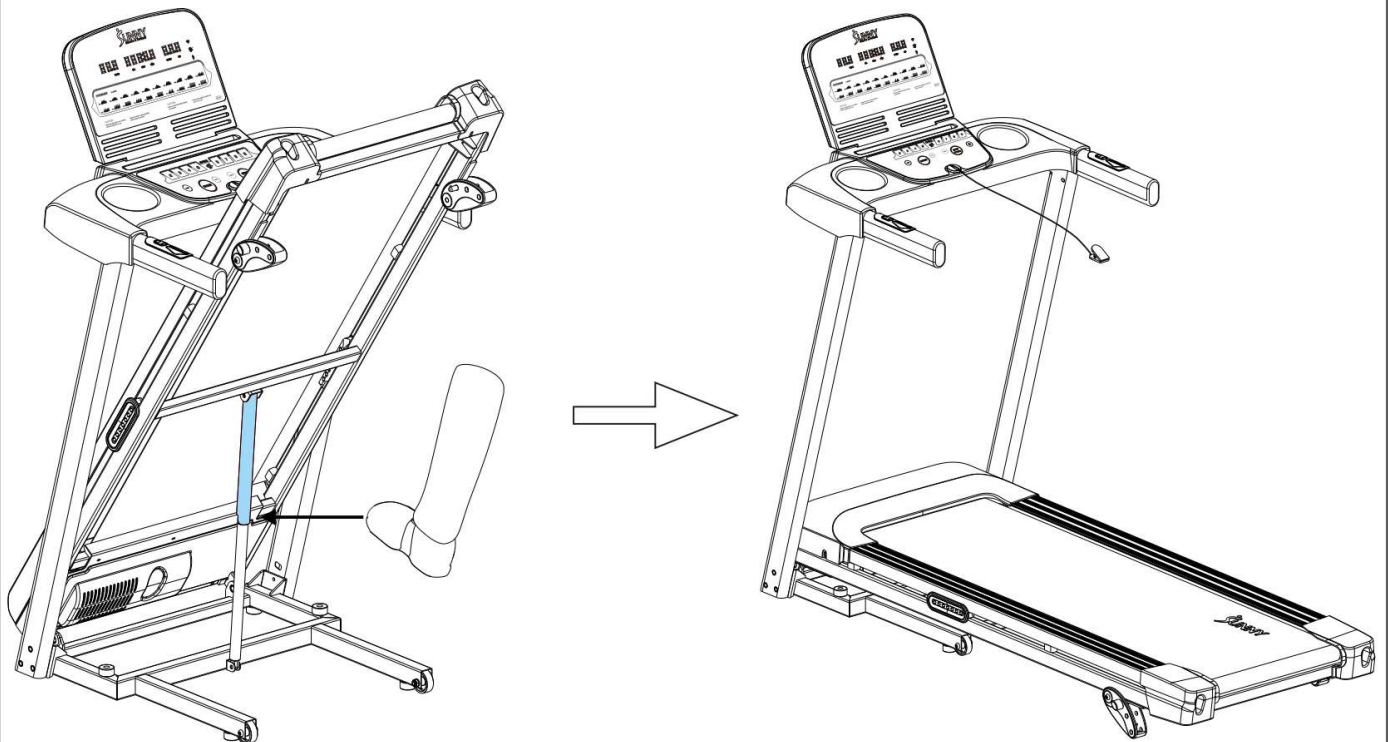

NOTE: LIGHTLY press in the center of the Cylinder and help down the running deck!

2-3

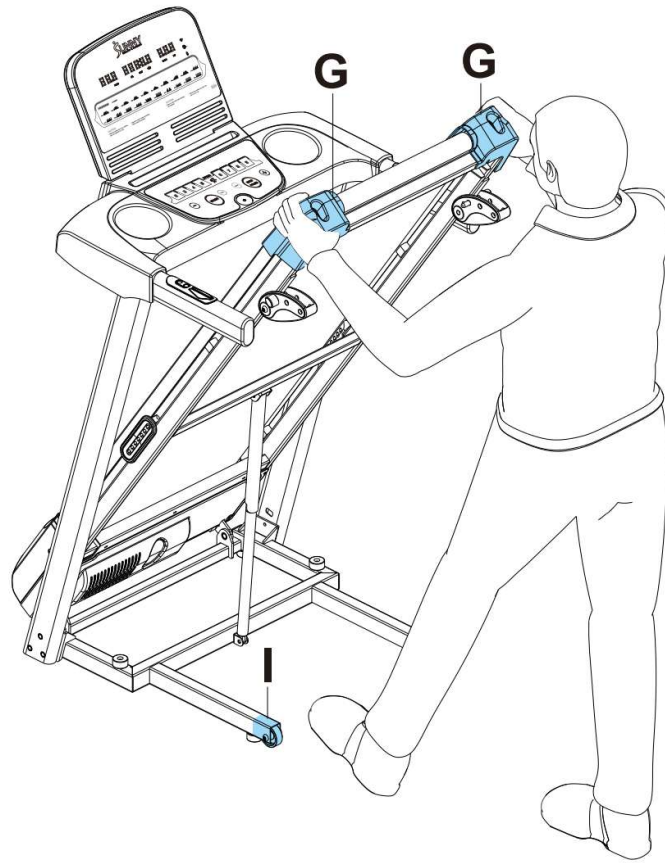

2-4

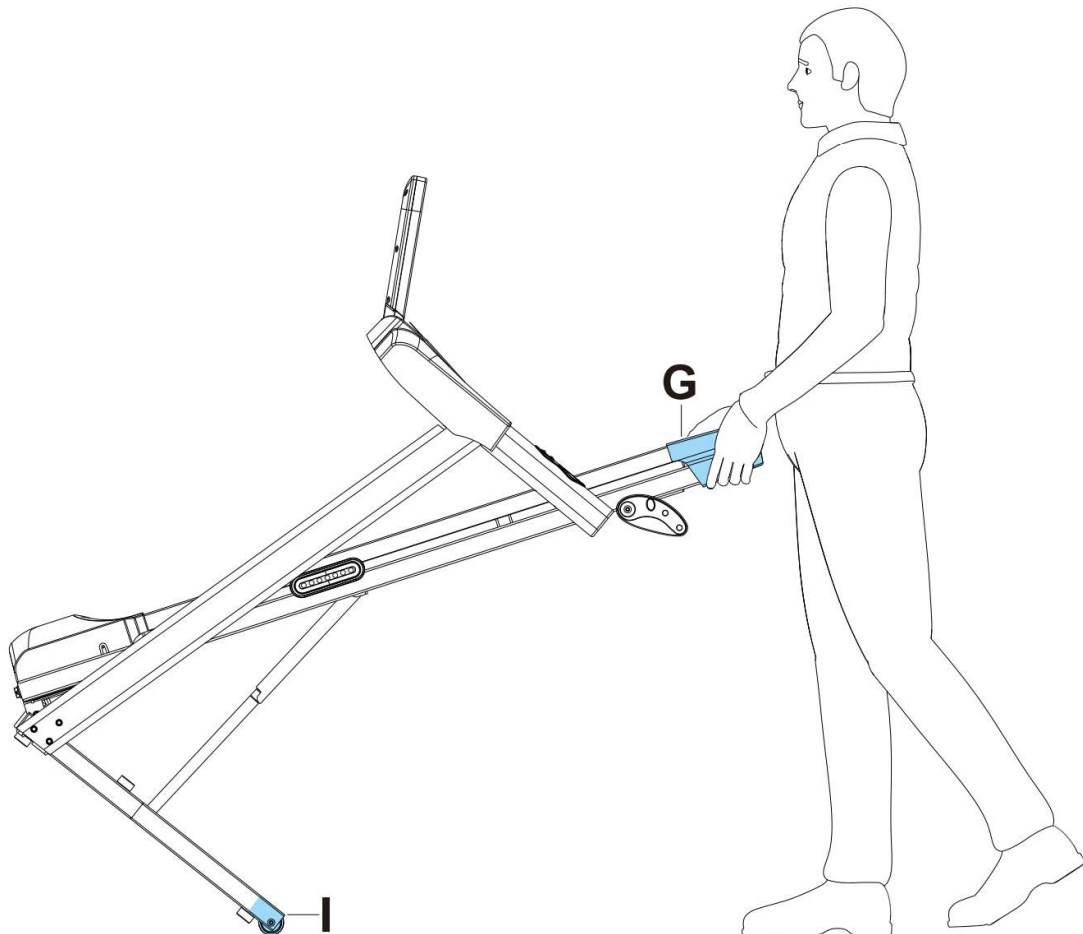

3-1

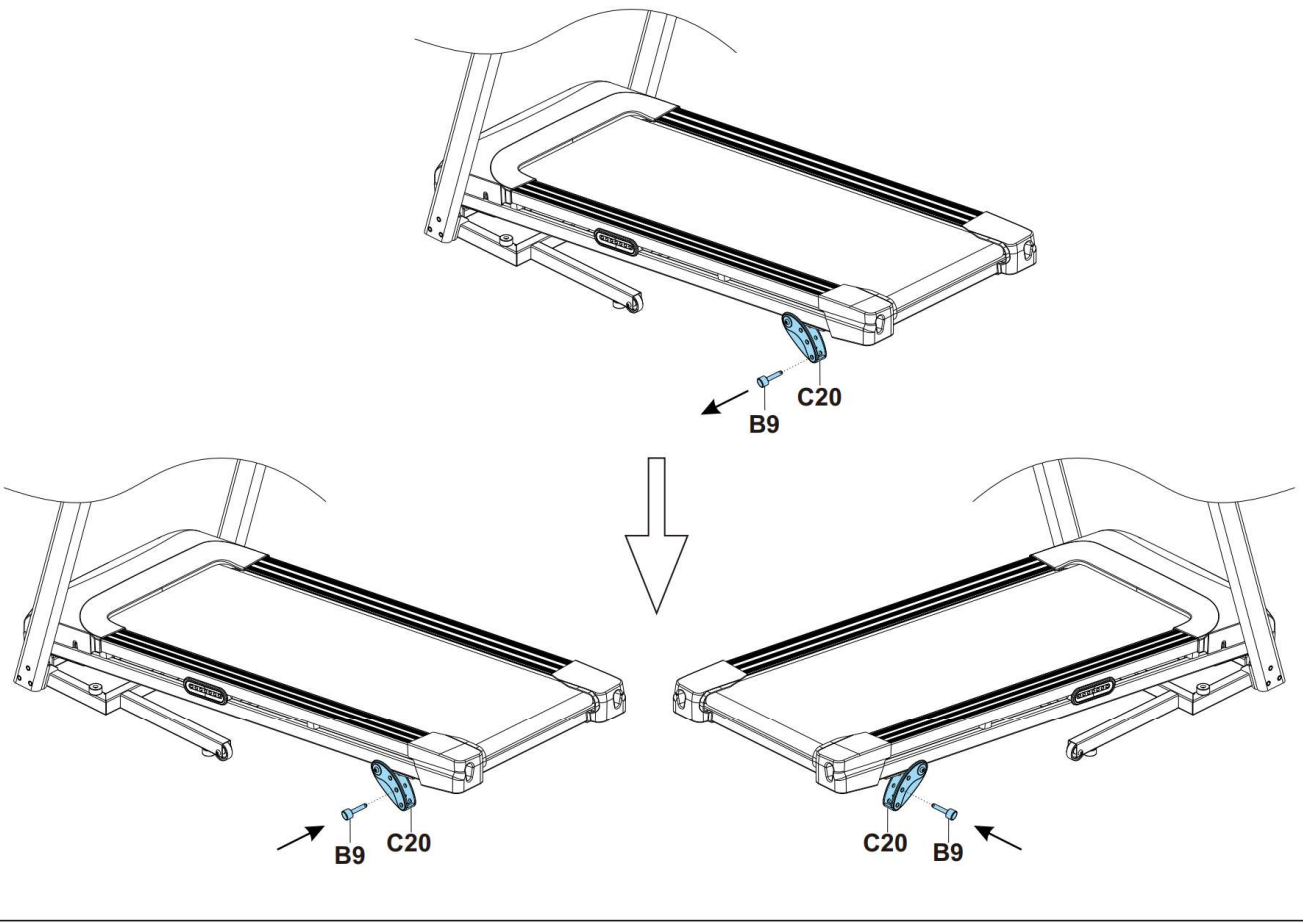

3-2

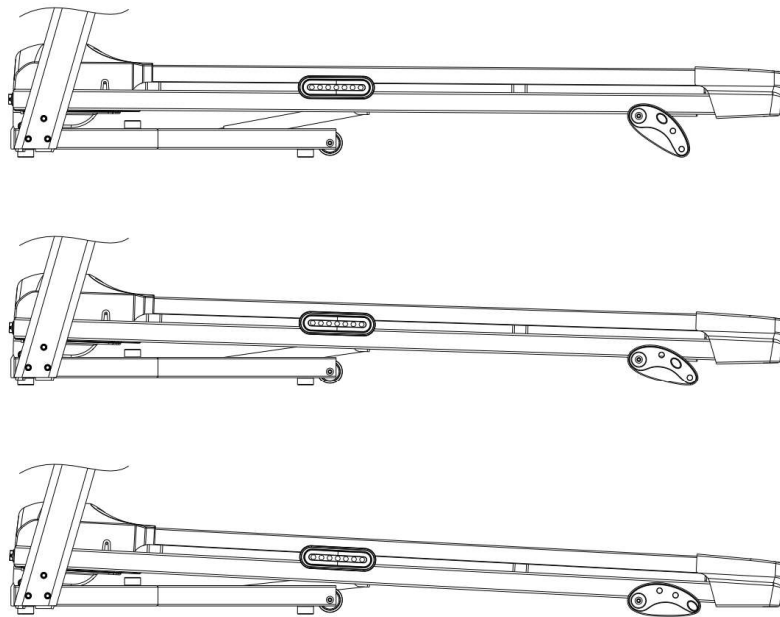

Lubricating The Treadmill

You will need to lubricate your treadmill before the first use! Lubricating the **Running Belt (No. B6)** and **Running Board (No. B5)** is essential as the friction affects the life span and operations of the treadmill. Inspect the **Running Belt (No. B6)** regularly. If you find any wear on the **Running Board (No. B5)**, please contact us at support@sunnyhealthfitness.com.

WARNING: Always unplug the treadmill from the electrical outlet before cleaning, lubricating, or repairing the unit.

HOW TO LUBRICATE:

1. Raise the **Running Belt (No. B6)** up on one side and apply lubricant to the **Running Board (No. B5)**. Repeat this process for the other side.
2. It is suggested that the treadmill be powered off for 10 minutes every 1 hour and fully powered off whenever not in use to better maintain the treadmill and prolong its life.
3. A loose **Running Belt (No. B6)** will result in the runner sliding off when in use, while too tight of a **Running Belt (No. B6)** will negatively affect the motor's performance and create more friction between the roller and **Running Belt (No. B6)**. The most suitable tightness for the **Running Belt (No. B6)** is when it is pulled out 50-75 mm from the **Running Board (No. B5)**.

NOTE: Do not make any adjustments to the **Running Belt (No. B6)** while applying lubricant.

The following timetable is recommended:

Light user (less than 3 hours/ week)	every 2 months
Medium user (3-5 hours/ week)	every 45 days
Heavy user (more than 5 hours/ week)	every month

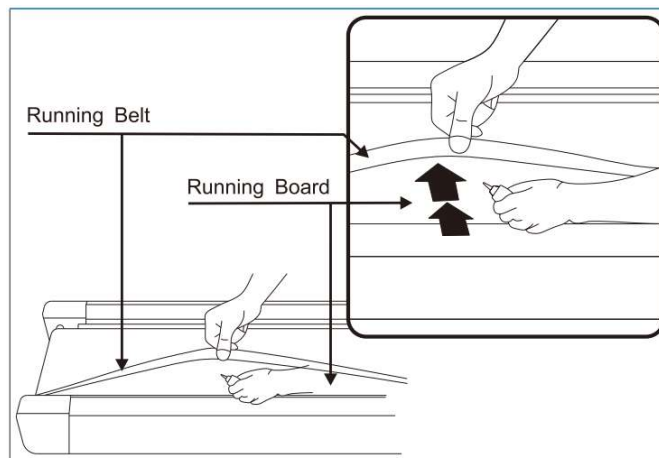

Maintenance Instructions

General cleaning will help to prolong the life and improve the performance of your treadmill. Keep the unit clean and maintained by dusting the components on a regular basis. Cleaning the two exposed sides of the **Running Belt (No. B6)** will prevent dust from accumulating underneath. Keep your running shoes clean so no dirt will stay on the **Running Board (No. B5)** and **Running Belt (No. B6)**. Clean the surface of the **Running Belt (No. B6)** by using a clean damp cloth. Keep liquids away from electrical parts and **Running Belt (No. B6)**.

ADJUSTING THE RUNNING BELT

Place the treadmill on level ground and set it at 3-5 MPH (5-8 KM/H) to check and see if the **Running Belt (No. B6)** drifts from the center. Adjust the **Running Belt (No. B6)** according to instructions below with **Allen Wrench (No. F1)**.

If the **Running Belt (No. B6)** drifts to the right, turn the right adjusting bolt $\frac{1}{4}$ turn *clockwise*, then turn the left adjusting bolt $\frac{1}{4}$ turn *counter-clockwise*. If the **Running Belt (No. B6)** does not move, repeat this step until it centers. Refer to image A.

If the **Running Belt (No. B6)** drifts to the left, turn the left adjusting bolt $\frac{1}{4}$ turn *clockwise*, then turn the right adjusting bolt $\frac{1}{4}$ turn *counter-clockwise*. If the **Running Belt (No. B6)** does not move, repeat this step until it centers. Refer to image B.

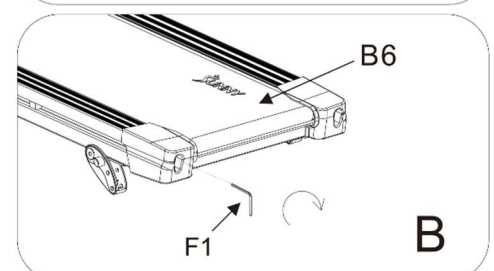
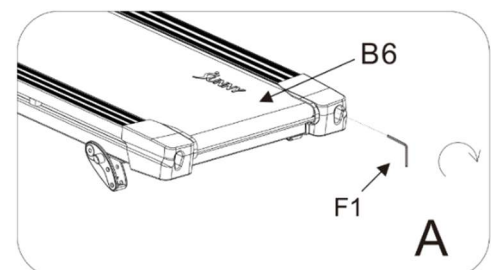

Over time, the **Running Belt (No. B6)** will loosen. To tighten the **Running Belt (No. B6)**, turn both the left & right sides adjusting bolts one full turn *clockwise*. Check the tension of the **Running Belt (No. B6)**. Continue this process until **Running Belt (No. B6)** is at the correct tension. Make sure to adjust both sides equally to ensure even alignment. Refer to image C.

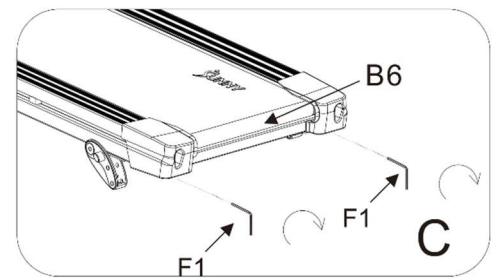

The Display Console

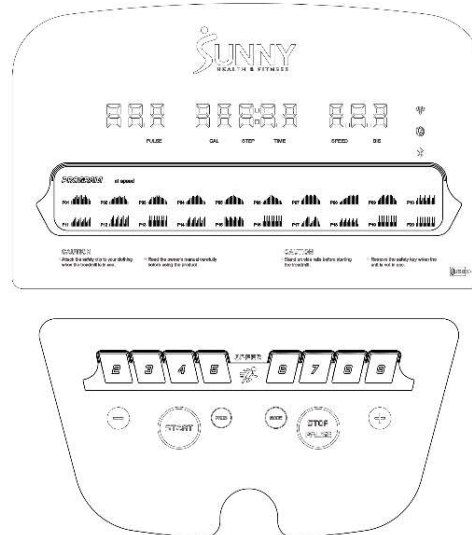

DISPLAY

- PROGRAM:** In addition to manual mode, there are 20 preset programs (P1-P20), 3 personalized user programs (U1-U3) and FAT program.
- SPEED:** The speed range is 1- 9 MPH (1-14 KM/H). The initial default speed is 1 MPH (1 KM/H).
- TIME:** Displays the time elapsed (0:00-99:59 MINS). If the time reaches 99:59, the treadmill will stop smoothly and display "End" then automatically reset to 0:00 after 5 seconds. When in Countdown Mode, it will count from the set time to 0:00. When the clock reaches 0:00, the treadmill will stop smoothly and display "End" then automatically reset itself after 5 seconds.
- DIS (DISTANCE):** Displays the total distance traveled or distance countdown (0.00- 99.9 MILES) / (0.00-99.9 KM). Displayed every 5 seconds.
- CAL (CALORIES):** Displays total calories burned or calories countdown (0.0-999 KCAL). Displayed every 5 seconds.
- PULSE:** Displays your pulse data when hands are placed on the sensors or connected to heart rate monitor (50-200 BPM). The console can be connected to the heart rate monitor at any time except in power saving mode.
NOTE: The heart rate monitor is not included. Wireless heart rate function works with SunnyFit Heart Rate Monitor HR200.
- SAFETY KEY:** The safety key lock acts as an emergency stop function. In case of emergency, simply remove the **Safety Key (No. C19)** from the top console and the top console will beep twice and bring the running belt to a complete stop.
- STEP:** Displays the total steps (1-99999 steps). Displayed every 5 seconds.

NOTE: The information displayed is an estimate only. Actual values may vary depending on factors such as body weight, resistance level, workout intensity, and other individual conditions. This information is provided for reference purposes only and should not be used for medical or dietary purposes.

UNIT CONVERSIONS FROM IMPERIAL TO METRIC SYSTEM

First, remove the **Safety Key (No. C19)** from **Console Assembly (No. G3)** then press "PROG" and "MODE" buttons together for 5 seconds. The display will show "9" or "14". It's in Imperial System when "9" is displayed. It's in Metric System when "14" is displayed.

NOTE: If treadmill is converted to Metric System, speed and distance will be measured in Kilometers and Kilometers/Hour.

FUNCTION BUTTONS/MANUAL MODE

- START:** Insert the **Safety Key (No. C19)** into the top console and press "START" button to start the treadmill. The treadmill will initiate at the default running speed of **1 MPH (1 KM/H)**.
- STOP/PAUSE:** When in use, press this button once to PAUSE your workout and the current workout data will still be shown. Press "STOP/PAUSE" button again to terminate your workout session completely and all data will be deleted and reset to the initial setting. In the STOP state, press and hold the "STOP/PAUSE" button for 6 seconds to disconnect the heart rate monitor. To reconnect the heart rate monitor, press and hold the "STOP/PAUSE" button for 6 seconds again.
- SPEED +/- BUTTONS:** During use, press these +/- buttons to increase or decrease your speed. The speed will adjust 0.1 MPH (0.1 KM/H) at a time.

4. **MODE:** Press this button to choose which **Countdown Mode** to preset before starting the treadmill.
- Press the "MODE" button to set the desired **H-1 (TIME)**, **H-2 [DIS (DISTANCE)]**, or **H-3 [(CAL (CALORIES))]** setting to countdown from.
 - H-1 (TIME):** Countdown is set at the initial time setting of 15:00 MINS. You may increase or decrease the set time by pressing the "SPEED +/-" buttons. The time setting range is from 5:00-99:00 MINS.
 - H-2 [DIS (DISTANCE)]:** Countdown is set at the initial distance setting of 1.00 MILE (1.00 KM). You may increase or decrease the set distance by pressing the "SPEED +/-" buttons. The distance setting range is from 0.5-99.9 MILES (0.5-99.9 KM).
 - H-3 [CAL (CALORIES)]:** Countdown is set at the initial calories setting of 50.0 KCAL. You may increase or decrease the set calories by pressing the "SPEED +/-" buttons. The calories setting range is from 10.0-990 KCAL.
 - Press "START" button to begin this exercise.
- NOTE:** Once the Countdown Mode program is complete, the treadmill will stop, then return to Manual Mode.
5. **2, 3, 4, 5, 6, 7, 8, 9 (QUICK SPEED BUTTONS):** Use these quick speed buttons to instantly bring the running belt to the desired speed of 2 MPH, 3 MPH, 4 MPH, 5 MPH, 6 MPH, 7 MPH, 8 MPH, or 9 MPH. If the treadmill is converted to Metric System, the quick speed buttons will display 2 KM/H, 3 KM/H, 4 KM/H, 5 KM/H, 6 KM/H, 7 KM/H, 8 KM/H, 9 KM/H.

PROGRAMS

Press the "PROG" button to select P1, P2,P19, P20. Press the "SPEED +/-" buttons to set the exercise time, then press "START" button to start your exercise. When the exercise is finished, the treadmill will display "End" and stop automatically.

Each program is divided into 16 exercise segments in an equal time division. Please use the chart below for Imperial or Metric system.

Program in Imperial System (Miles/Hour)

TIME PROGRAM		SET TIME/16															
		1	2	3	4	5	6	7	8	9	10	11	12	13	14	15	16
P1	SPEED	1.2	1.9	1.9	2.5	3.1	1.9	2.5	3.1	3.1	1.9	2.5	3.1	2.5	1.9	1.9	1.2
P2	SPEED	1.2	1.9	2.5	2.5	3.7	3.1	3.1	3.7	4.3	3.7	3.1	3.7	4.3	2.5	1.9	1.2
P3	SPEED	1.2	1.9	2.5	3.7	3.7	3.1	3.7	4.3	3.7	4.3	3.7	3.1	3.1	2.5	1.9	1.2
P4	SPEED	1.2	1.9	2.5	3.7	3.7	5	5	4.3	5	5.6	5	4.3	3.7	2.5	1.9	1.2
P5	SPEED	1.2	2.5	3.1	3.7	4.3	5	5	5.6	5	4.3	4.3	3.7	3.7	3.1	2.5	1.2
P6	SPEED	1.2	2.5	2.5	3.7	4.3	5	6.2	6.2	5.6	5	4.3	4.3	3.7	2.5	2.5	1.2
P7	SPEED	2.5	3.7	5	6.2	7.5	7.5	6.2	7.5	7.5	6.2	7.5	7.5	6.2	5	3.7	2.5
P8	SPEED	1.2	1.9	2.5	3.7	4.3	5	5	6.2	6.8	7.5	6.2	7.5	6.8	6.2	7.5	7.5
P9	SPEED	2.5	3.7	5	6.2	7.5	7.5	5	6.2	7.5	7.5	7.5	7.5	6.2	5	3.7	2.5
P10	SPEED	1.2	2.5	2.5	3.7	1.2	2.5	2.5	3.7	1.2	2.5	2.5	3.7	1.2	2.5	2.5	3.7
P11	SPEED	2.5	3.7	5	6.2	2.5	3.7	5	6.2	2.5	3.7	5	6.2	2.5	3.7	5	6.2
P12	SPEED	1.5	4	5.2	6.5	1.5	4	5.2	6.5	1.5	4	5.2	6.5	1.5	4	5.2	6.5
P13	SPEED	2.5	4.5	2.5	4.5	2.5	4.5	2.5	4.5	2.5	4.5	2.5	4.5	2.5	4.5	2.5	4.5
P14	SPEED	2.5	5	6.2	7.5	2.5	5	6.2	7.5	2.5	5	6.2	7.5	2.5	5	6.2	7.5
P15	SPEED	7.5	7.5	6.2	5	7.5	7.5	6.2	5	7.5	7.5	6.2	5	7.5	7.5	6.2	5
P16	SPEED	2.5	5.5	2.5	5.5	2.5	5.5	2.5	5.5	2.5	5.5	2.5	5.5	2.5	5.5	2.5	5.5
P17	SPEED	1.2	2.5	3.7	5	6.2	7.5	7.5	1.2	2.5	3.7	5	7.5	7.5	6.2	3.7	1.2
P18	SPEED	2.5	3.7	5	2.5	3.7	5	2.5	3.7	5	2.5	3.7	5	2.5	3.7	5	1.2
P19	SPEED	2.5	6.5	2.5	6.5	2.5	6.5	2.5	6.5	2.5	6.5	2.5	6.5	2.5	6.5	2.5	6.5
P20	SPEED	2.5	7.5	2.5	7.5	2.5	7.5	2.5	7.5	2.5	7.5	2.5	7.5	2.5	7.5	2.5	7.5

Program in Metric System (Kilometers/Hour)

TIME PROGRAM		SET TIME/16															
		1	2	3	4	5	6	7	8	9	10	11	12	13	14	15	16
P1	SPEED	2	5	5	5	10	10	5	5	5	3	3	2	5	5	3	2
P2	SPEED	2	2	7	2	2	7	7	12	4	4	12	4	4	12	4	2
P3	SPEED	2	4	9	9	4	4	8	8	10	10	12	4	4	8	4	2
P4	SPEED	2	6	6	6	12	12	12	12	6	6	3	3	3	5	5	2
P5	SPEED	2	4	6	12	12	12	3	3	3	3	12	12	12	6	4	2
P6	SPEED	2	4	5	5	6	6	8	8	6	6	8	8	6	9	6	2
P7	SPEED	2	7	7	9	9	4	4	12	12	4	4	8	8	4	4	2

P8	SPEED	2	2	6	6	6	8	9	10	11	12	9	5	5	5	3	2
P9	SPEED	2	4	8	10	2	4	8	10	2	4	10	2	4	10	4	2
P10	SPEED	2	5	6	7	8	9	10	11	10	9	8	6	7	5	4	2
P11	SPEED	2	5	6	7	9	9	6	9	6	9	6	10	6	10	7	2
P12	SPEED	2	6	8	10	2	6	8	10	2	6	8	10	2	6	8	10
P13	SPEED	4	7	4	7	4	7	4	7	4	7	4	7	4	7	4	7
P14	SPEED	2	8	10	12	4	8	10	12	4	8	10	12	4	8	10	2
P15	SPEED	2	12	10	8	12	12	10	8	12	12	10	8	12	12	10	2
P16	SPEED	4	9	4	9	4	9	4	9	4	9	4	9	4	9	4	9
P17	SPEED	2	4	6	8	10	12	12	2	4	6	8	12	12	10	6	2
P18	SPEED	2	6	8	4	6	8	4	6	8	4	6	8	4	6	8	2
P19	SPEED	4	10	4	10	4	10	4	10	4	10	4	10	4	10	4	10
P20	SPEED	2	12	4	12	4	12	4	12	4	12	4	12	4	12	4	2

USER PROGRAMS (U1-U3):

User program is made up of 16 segments. You are allowed to personalize each segment of your exercise by programming each individual segment's time duration, desired speed, and incline.

1. Press the "PROG" button to select U1, U2, or U3. Press the "SPEED +/-" buttons to set the exercise time.
2. Press "MODE" button to enter the setting mode and set the desired speed of the 1st segment by pressing the "SPEED +/-" buttons.
3. Press "MODE" button and your 1st segment is set.
4. Repeat the instructions above (2 to 3) until you've completed programming all 16 segments.
5. Press "START" button to save and start your exercise.

BODY FAT CALCULATION:

1. Press the "PROG" button until the window displays **FAT**.
2. Press "MODE" button to enter below by pressing the "SPEED +/-" buttons to set the data accordingly:
 - a. F1 – Gender
 - b. F2 – Age
 - c. F3 – Height
 - d. F4 – Weight
3. Hold the hand pulse sensors, it will start calculating and provide you with your BODY FAT.

NOTE: Average Body Fat score is 20-25.

F1	Sex	01 MALE	02 FEMALE
F2	Age	10 to 99 YEARS OLD	
F3	Height	40---80 INCHES (100-200 CM)	
F4	Weight	44---330 LBS (20-150 KG)	
F5	Body Fat	≤19	Underweight
	Body Fat	=(20---25)	Average Weight
	Body Fat	=(26---29)	Overweight
	Body Fat	≥30	Obesity

BLUETOOTH 

1. The Bluetooth indicator light will flash when the console is on or wakes from power saving mode. If no Bluetooth connection is established within 3 minutes, the Bluetooth indicator light will turn off.
2. The Bluetooth indicator light will stay on when it is connected.

WIRELESS HEART RATE 

1. The wireless heart rate indicator light will stay on when the heart rate monitor is connected.
2. The console can be connected to the heart rate monitor at any time except in power saving mode.
3. The wireless heart rate indicator light will flash when the console is on. If the heart rate monitor is not connected within 3 minutes, the wireless heart rate indicator light will turn off.

WIFI 

1. If the access point is not configured or fails to be configured, the WIFI indicator light will turn off.
2. After configuring the access point, the WIFI indicator light will flash during the connection to the server.
3. The WIFI indicator light will stay on when the server is successfully connected.

NOTE:

1. WIFI function only supports 2.4G frequency, not 5G frequency.
2. Please use SunnyFit APP to configure WIFI and configure it according to the wizard on SunnyFit APP.



APP CONNECTION

CONNECT SMART EQUIPMENT TO SUNNYFIT APP:

1. Scan to download SunnyFit from the app store.



2. Ensure that the Bluetooth function is turned on from your mobile device.
3. If this is your first time using the SunnyFit app, follow the in-app instructions to register for your free SunnyFit account and log in.
4. Begin any workout activity that matches your smart equipment, then follow the onscreen prompts to search for and connect to your smart equipment.
5. When connected, your stats and records will be displayed at the end of your course/session, and recorded in your account profile!

TROUBLESHOOTING

- If you are having trouble connecting your smart equipment, visit www.sunnyfit.com/guide or scan the QR code below:



- If you require additional support, please contact support@sunnyfit.com.

Exercise Instructions

GETTING STARTED:

Before starting any exercise programs, you should consult your physician to determine if you have any medical or physical conditions that could put your health and safety at risk or prevent you from using the equipment properly. Be aware of your body's signals. Incorrect or excessive exercise can damage your health. Stop exercising immediately if you experience any of the following symptoms: pain, tightness in your chest, irregular heartbeat, extreme shortness of breath, lightheadedness, dizziness, or feelings of nausea.

Turn on the power switch located next to the power cord. Get to know your treadmill. Before attempting to use the treadmill take some time to stand alongside it and familiarize yourself with the controls. Once you feel comfortable get on, you can stand with your feet on the foot rails and balance yourself by putting your hands on the handrails.

Next, attach the clip end of the **Safety Key (No. C19)** to your clothing and insert the magnetic end of the key into the top console. Press the "START" button to start the treadmill. The treadmill will start at the default speed of 1 MPH (1 KM/H). Once you feel comfortable, you may slowly increase the speed. When you are finished with your exercise, press the "STOP/PAUSE" button or remove the magnetic end of **Safety Key (No. C19)** to stop the treadmill.

EMERGENCY STOP:

Remove the **Safety Key (No. C19)** from the top console to stop the treadmill immediately. Once the treadmill reaches a full stop, the window display on the top console will show "---" and the treadmill will beep. To start the treadmill again, insert the magnetic end of **Safety Key (No. C19)** into the top console and press "START" button.

POWER SAVE FUNCTION:

Once the treadmill has been inactive for 10 minutes, it will adjust to *Power Saving Mode*. When the treadmill is in *Power Saving Mode*, the window display on the top console will shut off. To reactivate, press any button.

POWER OFF:

Power to the treadmill can be turned off at any time without risk during or after an exercise.

⚠ CAUTION!

1. We recommend that you maintain a slow speed at the beginning of a session and hold the handrails until you become comfortable and familiar with the treadmill.
2. Insert the magnetic end of the **Safety Key (No. C19)** into the top console and attach the opposite end with the safety clip to your clothing before beginning your workout. To end your workout, press the "STOP/PAUSE" button or remove the **Safety Key (No. C19)**. The treadmill will stop immediately.

Troubleshooting

Code	Description	Possible Reasons	How to Troubleshoot
-----	Safety key fault.	The safety key is not inserted correctly. Safety key sensor or safety key is damaged.	Insert the safety key properly. Replace the safety key sensor or safety key. If there's still a problem, replace the top console.
E01	Software overflow.	Overload.	Check wire connections from the console to the control board. If the wire has been punctured or damaged, you will need to replace it. If the problem is not rectified, you may need to replace the control board.
E02	Hardware overflow.	Overload.	Check if the incoming power supply is with correct voltage.
E04	Undervoltage protection.	The incoming voltage is too low. The control board is damaged.	Restart the treadmill. Check the incoming voltage to ensure it is correct. Check the control board, replace if damaged.
E05	Overvoltage protection.	The incoming voltage is too high. The control board is damaged.	Restart the treadmill. Check the incoming voltage to ensure it is correct. Check the control board, replace if damaged.
E06	Motor phase loss protection.	The motor wire is not connected, or the motor is damaged.	Check motor wires to see if the motor is connected. If the wire has been punctured or damaged, you will need to replace it. If the problem is not rectified, you may need to replace the motor.
E07	Motor lock protection.	The motor wire is not connected, or the motor is damaged.	Check motor wires to see if the motor is connected. If the wire has been punctured or damaged, you will need to replace it. If the problem is not rectified, you may need to replace the motor.
E08	The motor won't start.	The motor is damaged, or a moving part of the treadmill is stuck and therefore the motor is unable to rotate properly.	Inspect moving parts of the treadmill to ensure that they are operating correctly. Replace the motor if necessary.
E09	Motor overcurrent protection.	Running for a long time with high resistance.	Lubricate the treadmill. (see Page 11).
		The motor may be damaged.	Replace the motor.
E10	Current overload protection.	Running for a long time with high resistance.	Lubricate the treadmill. (see Page 11).
		The motor may be damaged.	Replace the motor.
		The control board may be damaged.	Replace the control board.
E12	Communication abnormality.	No communication from the top console to the control board.	Check to make sure the wires are connected properly, and the wires are without any punctures or damage. If this does not resolve the issue, check the control board and PCB IC to see if there's any damage, replace if necessary.

Parts List

No.	Description	Spec.	Qty.
A1	Main Frame		1
A2	Left Support Tube		1
A3	Right Support Tube		1
A4	Base Frame		1
A5	Console Bracket		1
A6	Motor Fixed Board (A)		1
A7	Motor Fixed Board (B)		1
B1	Motor	1.0HP	1
B2	Motor Belt	360EPJ	1
B3	Front Roller	42*496	1
B4	Rear Roller	42*472	1
B5	Running Board	1195*570*15	1
B6	Running Belt	2670*407*1.4	1
B7	Cylinder		1
B8	Incline Bushing	Φ15*Φ10*9.5	2
B9	Latch Pin		2
C1	Motor Cover		1
C2	Motor Bottom Cover		1
C3	Side Rail		2
C4	End Cap (L)		1
C5	End Cap (R)		1
C6	Console Top Cover		1
C7	Console Bottom Cover		1
C8	Panel Bottom Cover		1
C9	Panel Top Cover		1
C10	Panel Fixed Board		2
C11	Overlay		1
C12	Key Panel Sticker		1
C13	Cable Protector	Φ24*Φ18*12*9	1
C14	Flat Foot Pad	Φ31*Φ6*16	6
C15	Transportation Wheel	Φ49*Φ8.2*25	2
C16	Cushion	Φ30*20*16	4
C17	Middle Cushion	150*45*30	2
C18	Rubber Cushion	Φ30*7*2.0	2
C19	Safety Key		1
C20	Adjustable Foot Pad		2
C21	Rubber Cushion		2
D1	Locking Nut	M10	2
D2	Locking Nut	M8	6
D3	Locking Nut	M6	2
D4	Flat Washer	D10	2
D5	Flat Washer	D8	13
D6	Spring Washer	D8	4
D7	Serrated Washer	D8	6
D8	Spring Washer	D5	2
D9	Serrated Washer	D5	2

No.	Description	Spec.	Qty.
D10	Bolt	M8*50	2
D11	Bolt	M10*25	2
D12	Bolt	M8*15	5
D13	Bolt	M8*55	3
D14	Bolt	M8*45	1
D15	Bolt	M8*40	8
D16	Bolt	M8*35	2
D17	Bolt	M8*25	1
D18	Half Round Head Bolt	M8*15	2
D19	Bolt	M6*40	4
D20	Bolt	M6*30	2
D21	Bolt with Washer	M5*15	12
D22	Bolt	M5*15	14
D23	Bolt	M5*12	2
D24	Screw	M4*12	5
D25	Screw	ST4.0*45	4
D26	Self Tapping Self Drilling Screw	ST4.2*16	10
D27	Self Tapping Screw	ST4.2*16	24
D28	Screw	ST3*6	28
D29	Self Tapping Screw	ST4.2*25	2
E1	Controller		1
E2	Console		1
E3	Safety Key Sensor		1
E4	USB		1
E5	Computer Chip		1
E6	Lower Metal Dome Array		1
E7	Contact Wire		1
E8-1	Start/Stop Hand Pulse		1
E9-1	Speed Hand Pulse		1
E10	Upper Console Wire	800mm	1
E11	Lower Console Wire	100mm	1
E12	Power Line	2100mm	1
E13	Power Line Plug	6N-3	1
E14	Single Red Wire	100mm	3
E15	Single White Wire	100mm	2
E16	Grounded Line		3
E17	Power Switch		1
E18	Overload Protector	10A	1
E19	Magnetic Ring		1
E20	Filter	10A	1
F1	Allen Wrench	S6	1
F2	Allen Wrench	S5	1
F3	Silicone Oil	20ml	1
G1	Panel Assembly		1
G2	Console Top Cover Assembly		1
G3	Console Assembly		1

Register

Register your product and verify warranty terms:

Sunnyhealthfitness.com/warranty



Download

Track your fitness progress & join **FREE** workout courses!

Download SunnyFit App today!



Follow

Find us on social media



Contact

Get in touch with us for any questions

☎ 1-877-90SUNNY (877-907-8669)

✉ support@sunnyhealthfitness.com

www.sunnyhealthfitness.com