

REVEL®

PERFORMA **Be**⁴™

F328Be Loudspeaker Owner's Manual

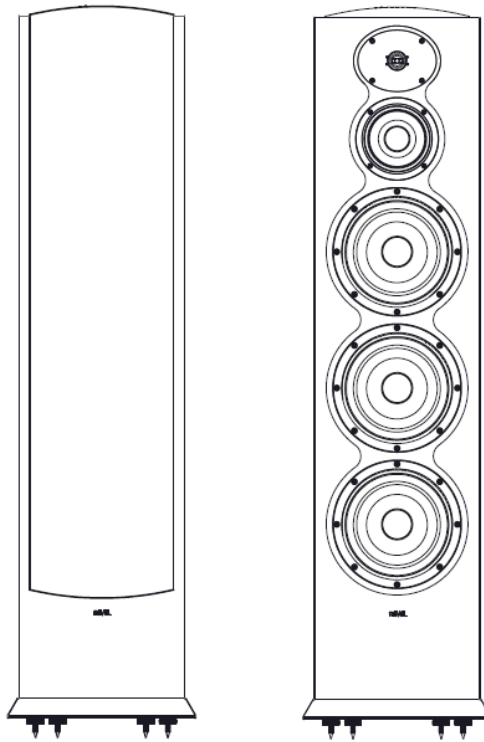

REVEL

IMPORTANT SAFETY INSTRUCTIONS

1. Use only attachments/accessories specified by the manufacturer.
2. Use only with the cart, stand, tripod, bracket, or table specified by the manufacturer or sold with the apparatus.  When a cart is used, use caution when moving the cart/apparatus combination to avoid injury from tip-over.
3. Refer all servicing to qualified service personnel. Servicing is required when the apparatus has been in any way, such as when the power-supply cord or plug is damaged, liquid has been spilled or objects have fallen into the apparatus, or the apparatus has been exposed to rain or moisture, does not operate normally or has been dropped.



This product must not be disposed of or dumped with your other household waste. You are liable to dispose of all your electronic or electrical waste equipment by relocating over to the specified collection point for recycling of such hazardous waste. Isolated collection and proper recovery of your electronic and electrical waste equipment at the time of disposal will allow us to help conserving natural resources. Moreover, proper recycling of the electronic and electrical waste equipment will ensure safety of human health and environment. For more information about electronic and electrical waste disposal, recovery, and collection points, please contact your local city center, household waste disposal service, shop from where you purchased the equipment, or manufacturer of the equipment.

WEEE NOTICE

The Directive on Waste Electrical and Electronic Equipment (WEEE), which entered into force as European law on 14/02/2014, resulted in a major change in the treatment of electrical equipment at end-of-life.

The purpose of this Directive is, as a first priority, the prevention of WEEE, and in addition, to promote the reuse, recycling and other forms of recovery of such wastes so as to reduce disposal. The WEEE logo on the product or on its box indicating collection for electrical and electronic equipment consists of the crossed-out wheeled bin, as shown below.

ROHS COMPLIANCE

This product is in compliance with Directive 2011/65/EU and (EU)2015/863 of the European Parliament and of the Council of 31/03/2015 on the restriction of the use of certain hazardous substances in electrical and electronic equipment.

TABLE OF CONTENTS

UNPACKING THE F328Be.....	3
ABOUT REVEL PERFORMABe LOUDSPEAKERS.....	4
FEATURE HIGHLIGHTS.....	4
F328Be OVERVIEW.....	4
INSTALLATION CONSIDERATIONS.....	4
LOUDSPEAKER PLACEMENT.....	5
ADJUSTABLE SPIKES.....	5
LISTENING ROOM ACOUSTICS.....	5
ACOUSTIC TREATMENT MATERIALS.....	5
MAKING CONNECTIONS.....	6
BINDING POSTS.....	6
OBSERVE PROPER POLARITY.....	6
SPEAKER CABLE.....	6
MINIMUM WIRE GAUGE.....	6
F328Be.....	6
SINGLE-WIRED CONNECTION.....	6
BI-WIRED CONNECTIONS.....	7
VERTICAL BI-AMPED CONNECTIONS.....	7
HORIZONTAL BI-AMPED CONNECTIONS.....	7
OPTIMIZING PERFORMANCE.....	8
PORT PLUGS.....	8
LOUDSPEAKER VOLUME LEVELS.....	8
CARING FOR YOUR LOUDSPEAKERS.....	9
GRILLES.....	9
F328Be.....	9
CABINET FINISH.....	9
SPECIFICATIONS.....	9
LIMITED WARRANTY.....	9

UNPACKING THE F328Be

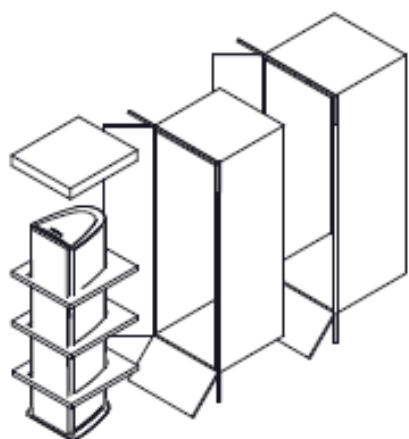

Unpack the F328Be in the order of the illustrations below.



Step 1

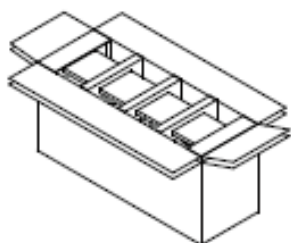

Step 2

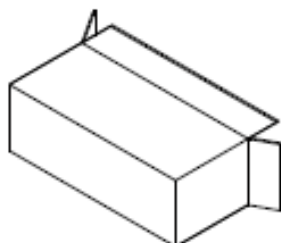

Step 3

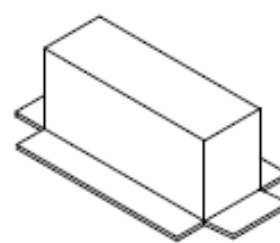

Step 4

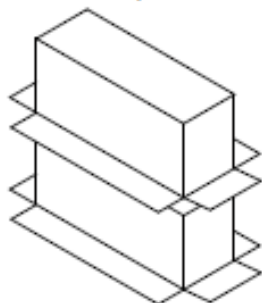

Step 5

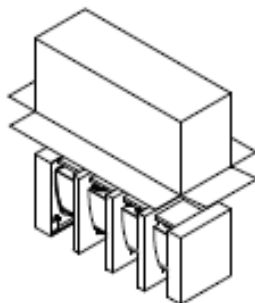

Step 6

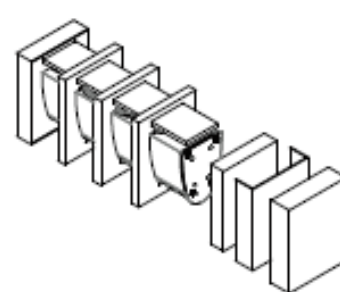

Step 7

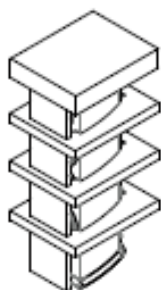

Step 8

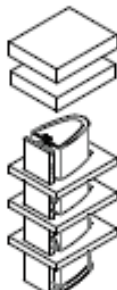

Step 9

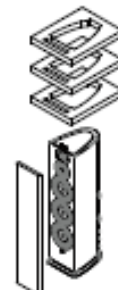

ABOUT REVEL PERFORMABE LOUDSPEAKERS

FEATURE HIGHLIGHTS

- Beryllium Dome Tweeter
- 6th-generation Acoustic Lens Waveguide
- Deep Ceramic Composite (DCC™) Cone Midrange and Woofers
- Wide bandwidth and dynamic range with minimal dynamic compression
- High-order Crossovers with Rim Capacitors and Air Core Inductors
- Premium High-Gloss Finishes: Black, White, Walnut, Metallic Silver

Thank you for purchasing the Revel PerformaBe loudspeakers. These true full-range loudspeakers deliver an impressive combination of wide frequency range, uncompressed dynamic range and low distortion across the entire audible spectrum.

The tweeter dome is pure Beryllium (Be), a rare and costly metal with a multitude of properties that make it the ideal tweeter dome material. Beryllium is extremely low mass (approximately half the weight of aluminum, titanium and diamond) yet up to 4.5 times stiffer than aluminum or titanium, yielding superior high frequency extension and resolution to 40kHz. Its high thermal conductivity helps cool the voice coil for increased reliability. This newly developed tweeter sets a new standard of transparency for speakers anywhere near the PerformaBe's class. The tweeter's integrated 6th generation acoustic lens waveguide is based on a breakthrough mathematical approach that accurately matches the tweeter's dispersion to that of the midrange transducer in the crossover region. This gives the loudspeaker very smooth sound over an exceptionally wide listening area—an important contributor to lifelike imaging for multiple listeners in a room. Further, the remarkable waveguide actually increases the tweeter's dispersion at frequencies above the crossover range. The Revel PerformaBe's low frequency and midrange transducers feature newly developed Deep Ceramic Composite (DCC) cone technology. With DCC the aluminum cone is exposed to intense plasma discharge in order to fuse a deep layer of ceramic to both sides of the cone, thereby stiffening and damping the cone far beyond untreated aluminum. DCC technology reduces cone resonance and promotes ideal piston motion; the benefits are immediately audible in midrange purity and detail retrieval. Their cast aluminum frames eliminate another source of resonance that is common in many lesser-quality loudspeakers. The PerformaBe models employ a sophisticated fluid-model designed low frequency port with identical flares on both ends. This greatly minimizes dynamic compression and port-generated noise, assuring low distortion low frequency performance.

The PerformaBe enclosures are similar to our flagship L1tima2 Series. The fully curved enclosure is inherently stiffer than conventional rectangular enclosures. The cabinet walls are formed with contiguous wood layers to damp material resonance, while strategically placed braces eliminate the possibility of enclosure-induced coloration. These beautiful, modern enclosures are finished in high-gloss black, white, metallic or genuine American walnut in a process (developed and overseen by Italian luxury cabinet makers) that exceeds automotive finish quality. The loudspeaker grilles are designed to minimize diffraction to maintain perfect three-dimensional imaging. The magnetic grille attachment method completely eliminates ugly hardware on the loudspeaker baffle. Whether you use them with or without grilles PerformaBe speakers will always present a clean, sophisticated appearance.

Revel Performa Be's crossover networks features carefully selected components that contribute to great performance and benchmark setting value. These high-order crossover networks dramatically reduce distortion and dynamic compression for clear sound that maintains the same quality over a very wide dynamic range. These precision networks optimize the speakers' timbre accuracy, enhancing musical enjoyment for listeners who are anywhere in the room, not only those seated on-axis to the loudspeakers. Revel-designed binding posts are heavily gold plated and include an articulated section that allows for more secure connections when using spade lugs. The floor standing F328Be includes two sets of binding posts that enable the loudspeakers to be bi-wired or bi-amped.

During development every Revel loudspeaker model is compared to competitive models in our unique position-independent double-blind listening lab. This process utilizes the latest psychoacoustic research to assure that these listening tests are valid, enabling us to verify that all Revel loudspeakers are superior to their competitors before they are allowed to go into production.

F328Be OVERVIEW

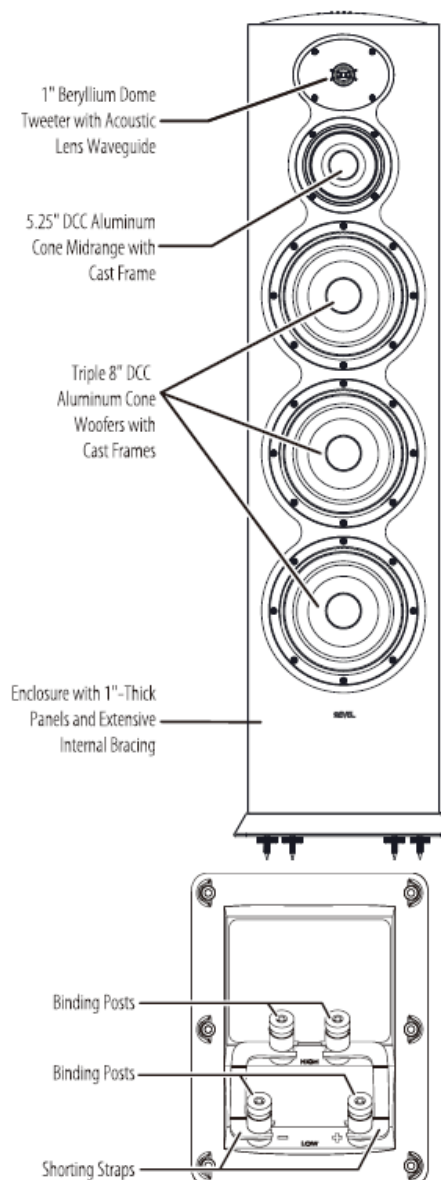

F328Be Input Plate

INSTALLATION CONSIDERATIONS

Loudspeaker fidelity depends on the following three factors: loudspeaker accuracy, loudspeaker placement, and listening room acoustics. Experimenting with loudspeaker placement and listening room acoustics will have the most significant impact on the loudspeakers' performance.

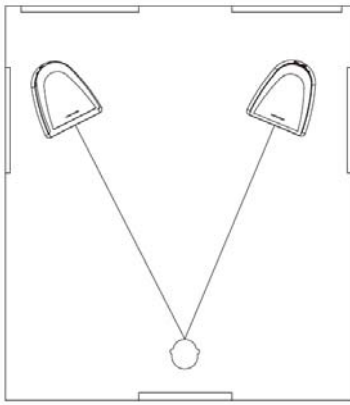

LOUDSPEAKER PLACEMENT

The following are important loudspeaker placement considerations for all models:

- Remove all obstructions between the loudspeaker and the primary listening position. For instance, a coffee table between the loudspeaker and the primary listening position will create reflections that will degrade stereo imaging and timbre. Placing the loudspeakers near large objects may also cause unwanted reflections.
- For the best stereo imaging, place the loudspeakers so that they are both the same distance from the primary listening position and so they are both the same distance from the side walls, as shown in the illustration at the top of the next column.
- For optimal stereo imaging and timbre, aim the loudspeakers directly toward the primary listening position as shown in the illustration above. If you wish to widen the stereo soundstage you can reduce this toe-in angle, even to the point at which the loudspeakers are pointing straight forward.
- Moving the loudspeakers farther from the front and side listening room walls will improve stereo imaging and the sense of spaciousness in the listening space.
- Moving the loudspeakers closer to the corners or walls of the listening room will increase bass level.

ADJUSTABLE SPIKES

Four adjustable spikes are included for each F328Be loudspeaker. You can install these spikes in the bottom of the loudspeaker cabinets to provide optimal stability, accommodating installations on tile, hardwood, or carpeted floors.

To install and adjust the spikes:

1. Place the loudspeaker on its side on a soft towel or carpeted floor.
2. Screw the spikes into the fittings on the bottom of the loudspeaker. The spikes can be installed with either the pointed end or round end protruding from the cabinet.

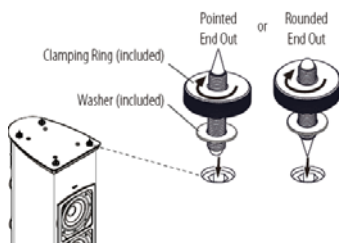

NOTE: When moving the F328Be with the spikes installed, avoid dragging the loudspeaker across the floor.

- If the loudspeakers are to be placed on a carpeted floor, install the spikes with the pointed ends protruding from the cabinet.
- If the loudspeakers are to be placed on a wood, linoleum or tile floor, install the spikes with the round ends protruding from the cabinet. After determining the final locations for the speakers, you can place coins or use specific discs under the spikes to protect the floor surface from damage.

NOTE: If you prefer to install the spikes with the pointed ends protruding from the cabinet, you must place coins or similar items under the spikes to avoid damaging the floor surface.

3. Rotate the locking ring clockwise to firmly secure the spike to the cabinet. Make sure to thread the locking rings of all four spikes to achieve a level balance when the loudspeaker is placed right side up on the floor.

CAUTION: Floor-standing loudspeakers such as the F328Be have a high center of gravity, which may cause them to fall if tipped or improperly positioned. To avoid this, anchor the loudspeaker to the floor and/ or wall using the same procedures and hardware used to anchor bookcases, wall units, and other furniture. HARMAN International Industries, Inc. assumes no responsibility for proper selection and installation of hardware or for any personal injuries or product damages resulting from improper installation or a fallen loudspeaker.

LISTENING ROOM ACOUSTICS

Listening rooms have a profound impact on sound, particularly at lower frequencies. In fact, the effect of the listening room can dominate sounds below around 400Hz. Ideally, listening rooms would include optimized dimensional ratios to minimize the effects of room resonances. But in reality, most listening rooms are not designed to enhance loudspeaker performance.

The interaction between loudspeakers and listening rooms is complex, with two important determinants that affect the loudspeaker and the listener:

- Surfaces and other boundaries often cause large peaks and dips in low-frequency response.
- All rooms suffer, at least to some degree, from standing waves (also known as room modes or resonances) that create large low-frequency response errors. Bass loudness can vary plus or minus 12dB or more in different areas of the room.

Unfortunately, there is no simple solution that addresses both of these factors. Even computer software programs that examine one or both factors may not calculate proper primary listening position or loudspeaker placement values.

In most cases, proper selection of the primary listening position combined with proper placement of the loudspeaker can result in superior performance at lower frequencies. The difference between superior and inferior results is often just a small adjustment of the

ACOUSTIC TREATMENT MATERIALS

The Revel PerformaBe models feature high-order filters that optimize the loudspeakers' on-axis and off-axis response, minimizing sonic degradations that occur in overly "live" rooms (those with surfaces that are acoustically reflective). Many listeners choose to place acoustic treatment materials at the room's primary reflection points to reduce these reflections. The most important locations are the first reflection points on the front and side walls. Either broadband acoustic absorbers or diffusers may be placed at the first reflection points on the rear wall.

NOTE: There are numerous options for absorbent material. None are superior to low-cost fiberglass. It is important to use absorbers that are at least four inches thick, to avoid altering the spectral response of the loudspeakers. If sculpted foam is used, it must be at least eight inches thick, as such absorbers are less efficient than non-sculpted foam.

Because the listener's eyes and ears are on the same plane, the "mirror method" is an accurate determinant of first reflection points. This method can be used to determine reflection points for side walls, rear walls, front walls, and even the ceiling. Applying acoustic treatment materials to the side walls is most important, followed by the ceiling, front wall and rear wall.

To determine reflection points using the mirror method:

1. Once the loudspeakers have been placed, sit in the primary listening position and ask another person to slide a mirror along the listening room walls.
2. Note the locations at which you can see either loudspeaker in the

mirror from the primary listening position. Be sure to look for both loudspeakers in the reflection on each room boundary. These are reflection points that require acoustic treatment materials.

If acoustic treatment materials are not available, hanging a rug over the reflection points will help reduce sonic degradation in overly “live” rooms. Carpeting the floor area between the loudspeakers and the primary listening position and placing irregular surfaces such as bookcases at the first reflection points will also help minimize strong reflections.

MAKING CONNECTIONS

CAUTION: Never make or break connections unless all system components are powered off.

BINDING POSTS

These gold-plated terminals provide connections from the power amplifier(s) to provide secure connection for speaker cables terminated with banana plugs, spade lugs, pin connectors or bare wire.

OBSERVE PROPER POLARITY

Connect the amplifier’s positive (+) terminal to the positive (+) terminal on the corresponding speaker; connect the amplifier’s negative (–) terminal to the negative (–) terminal on the corresponding speaker. Do not reverse polarities (that is, do not connect + to –, or – to +) when making connections. Doing so will cause poor stereo imaging and diminished bass response.

SPEAKER CABLE

Use high-quality loudspeaker cable with a maximum total loop resistance of 0.07 Ohms or less for each wire run. Refer to the table below to determine the appropriate wire gauge for your installation.

MINIMUM WIRE GAUGE

Maximum Wire Length (Feet)	Maximum Wire Length (Meters)	Minimum Wire Gauge (AWG)
<87	<27	6
<69	<21	7
<58	<18	8
<43	<13	9
<34	<10	10
<27	<8	11
<22	<7	12
<17	<5	13
<14	<4	14
<11	<3.5	15
<9	<3	16
<7	<2	17
<5	<1.5	18

NOTE: High loop resistances that exceed 0.07 Ohms (for each wire run) will cause the loudspeaker’s filter network to be mis-terminated, resulting in considerable degradation of sound quality.

F328Be

The F328Be has one pair of high frequency and one pair of low frequency binding posts that come from the factory connected by a pair of shorting straps (see below). The two sets of binding posts can be configured for single-wire, bi-wired, or bi-amped connections. See the instructions on this page through page 10 for additional information.

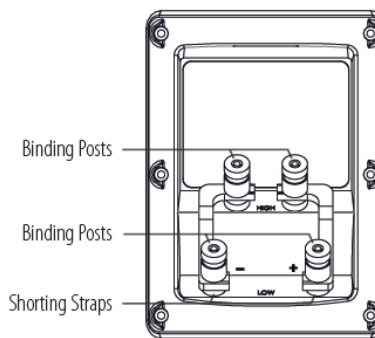

Before making connections to the F328Be speakers note the following:

- The standard connection method uses a single loudspeaker cable. The F328Be is equipped with two pairs of input terminals to allow for bi-wiring or bi-amping. While Revel does not endorse one particular connection method over another, these additional connection options are available if desired. The design of this loudspeaker is such that optimal performance can be attained using the standard connection method.
- Vertical bi-amped connections (see below) must be made with identical power amplifiers. Horizontal bi-amped connections (see below) can be made with identical or non-identical power amplifiers with identical gain factors.
- When making bi-amped connections, both power amplifiers must receive identical input signals from the associated preamplifier. If the associated preamplifier offers two connectors per output channel, each power amplifier can be connected to a separate connector for the same output channel of the preamplifier. If the associated preamplifier does not offer two connectors per output channel “Y” adaptors are required.
- No matter which connection method you choose, the speaker cables used for the left and right loudspeakers should always be the same length.
- If desired, contact your authorized Revel dealer for information about the suitability of power amplifier components before connecting the F328Be to your power amplifier(s).
- Review the owner’s manuals for all associated audio components to determine their correct connection procedures.

NOTE: Do not use an electronic crossover network when bi-amping Revel F328Be loudspeakers. Doing so will cause a considerable degradation of sound quality.

SINGLE-WIRED CONNECTION

NOTE: Do not remove the shorting straps between the speaker terminals.

Single-wired connections are the most common. These are made between one pair of F328Be input terminals and one power amplifier output channel as shown below.

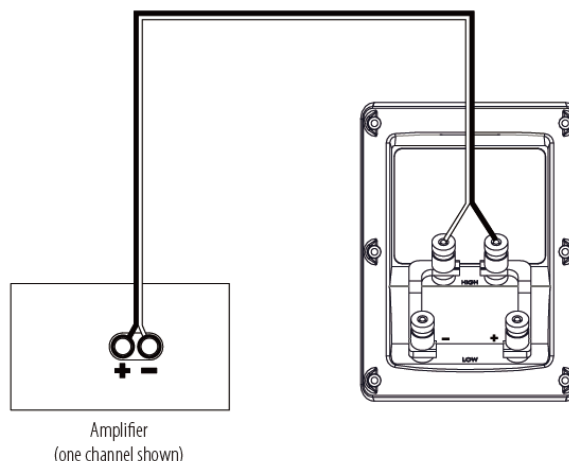

To make single-wire connections:

1. Connect one speaker cable to the desired set of F328Be input terminals. (The high-frequency – “HIGH” – input terminals are recommended.) Then connect the other end of that speaker cable to the desired power amplifier output channel.
2. Repeat step 1 to connect the second F328Be to the power amplifier’s remaining output channel.

BI-WIRED CONNECTIONS

CAUTION: Remove the shorting straps before making bi-wired connections. Failure to do so may cause damage to some power amplifiers.

Bi-wired connections use two sets of speaker cables to connect both sets of F328Be input terminals to a single power amplifier output channel as shown below.

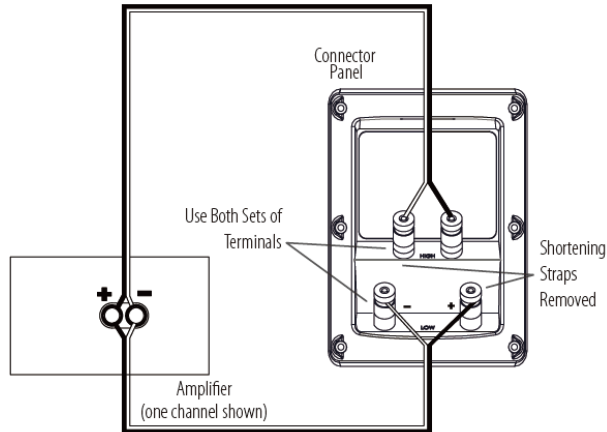

1. Remove the shorting straps.
2. Connect one speaker cable to the high-frequency set of F328Be input terminals. Then connect the other end of that speaker cable to the desired power amplifier output channel.
3. Connect another speaker cable to the low-frequency set of F328Be input terminals. Then connect the other end of that speaker cable to the same power amplifier output channel that you connected in step 2.
4. Repeat steps 1, 2 and 3 to connect the second F328Be to the power amplifier’s remaining output channel.

VERTICAL BI-AMPED CONNECTIONS

CAUTION: Remove the shorting straps before making bi-amped connections. Failure to do so may cause damage to some power amplifiers.

Vertical bi-amped connections are made between both pairs of F328Be input terminals and two separate output channels of a single power amplifier. Each F328Be loudspeaker is connected to an individual power amplifier, which can sometimes increase sonic performance. The power amplifiers for the two loudspeakers must be identical.

NOTE:

- Vertical bi-amped connections must be made using two identical power amplifiers, one for each loudspeaker.
- When making vertical bi-amped connections, both power amplifier channels must receive identical input signals from the associated preamplifier. If the associated preamplifier does not have two output

connectors for each channel, “Y” adaptors are required.

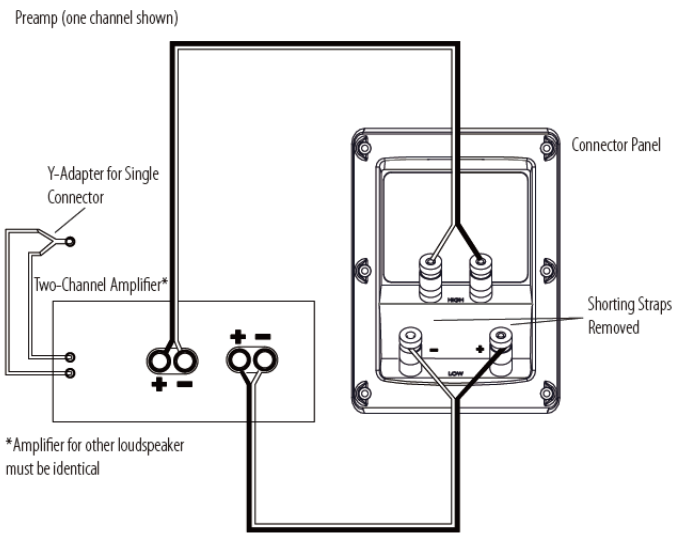

1. Remove the shorting straps.
2. Connect one speaker cable to the high frequency set of F328Be input terminals. Then connect the other end of that speaker cable to the desired power amplifier output channel.
3. Connect another speaker cable to the low-frequency set of F328Be input terminals. Then connect the other end of that speaker cable to another output channel of the same power amplifier you connected to the high-frequency input terminals.
4. Connect both amplifier channel inputs to the output of a single preamplifier channel. If the preamp only has one connector for the channel, use a “Y” adaptor.
5. Repeat steps 1, 2 and 3 to connect the second F328Be to another, identical power amplifier. Repeat step 4 to connect the second amplifier to the preamplifier’s other channel.

HORIZONTAL BI-AMPED CONNECTIONS

CAUTION: Remove the shorting straps before making bi-amped connections. Failure to do so may cause damage to some power amplifiers.

The two power amplifiers can be identical or non-identical, but they must have identical gain factors. If their gain factors are not identical, at least one of the amplifiers must have a means of adjusting its input level. Contact your authorized Revel dealer for assistance.

Horizontal bi-amped connections are made between both pairs of F328Be input terminals and two separate output channels of two separate power amplifiers. The F328Be’s set of high-frequency input terminals is connected to one power amplifier, while the F328Be’s set of low-frequency input terminals is connected to the other power amplifier.

NOTE: When making horizontal bi-amped connections, both power amplifiers must receive identical input signals from the associated preamplifier. If the associated preamplifier does not have two output connectors for each channel, “Y” adaptors are required.

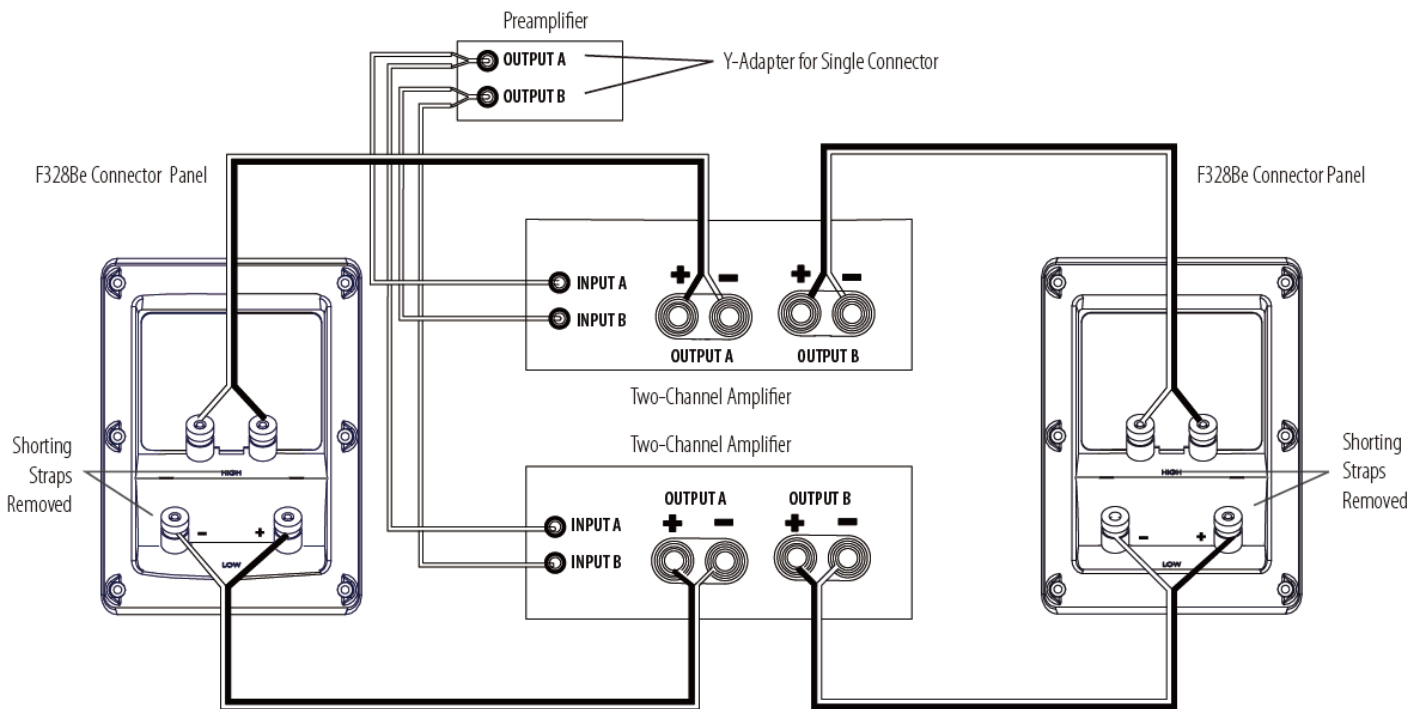

1. Remove the shorting straps
2. Connect one speaker cable to the high-frequency set of F328Be input terminals. Then connect the other end of that speaker cable to the desired power amplifier output channel.
3. Connect another speaker cable to the low-frequency set of F328Be input terminals. Then connect the other end of that speaker cable to the desired output channel on another power amplifier.
4. Repeat step 2 to connect the high frequency set of input terminals on

5. Repeat step 3 to connect the low-frequency set of input terminals on the second F328Be to the other channel of the power amplifier that was connected in step 2.
6. Connect the left and right channel inputs of the high-frequency amplifier to the preamplifier's left and right outputs. Repeat for the left and right inputs of the low-frequency amplifier. If the preamplifier only has one connector for each channel, use "Y" - adaptors.

OPTIMIZING PERFORMANCE

PORT PLUGS

Revel PerformaBe loudspeakers include a pair of foam port plugs that can be used to adjust the loudspeaker's low-frequency performance in certain installation situations.

If your loudspeakers are built into an entertainment center or shelving unit, or if the loudspeaker is located less than about two feet (0.61m) from walls or other large objects, inserting the port plugs into the loudspeaker's port openings can reduce the overly-aggressive bass output that can be created by the speaker's proximity to large bass energy reflecting surfaces.

Insert the port plugs into the loudspeaker's port tubes opening far enough so that the end of the plug is flush with the inside end of the port tube's flared section.

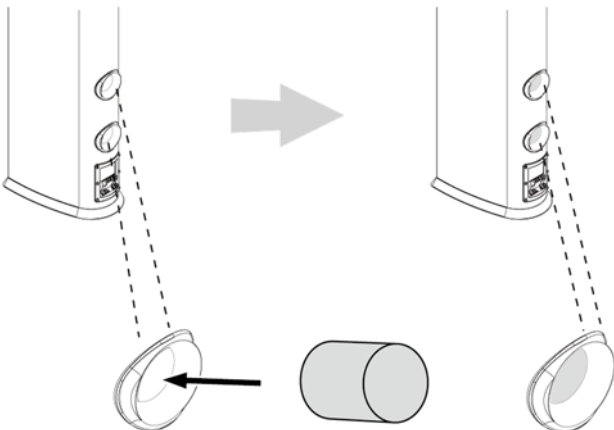

CAUTION: Be careful not to insert the port plugs so far into the port tubes that it falls inside of the speaker.

LOUDSPEAKER VOLUME LEVELS

The high-order filters employed in Revel PerformaBe series loudspeakers include steep cut-offs to reduce potential transducer damage from "out-of-band" frequencies. Combined with carefully selected transducers and filter network components, this approach helps the PerformaBe floorstanding loudspeakers maintain their performance under extreme operating conditions.

However, all loudspeakers have limits when it comes to continuous playback. To avoid exceeding these limits, avoid playback at volume levels that distort or strain the sound.

CAUTION: To avoid damage, reduce the volume level immediately if the loudspeaker sound is not clean and clear. If you hear distortion, turn it down!

Once you have installed and connected your loudspeakers follow these steps the first time you turn your new PerformaBe loudspeakers on:

1. Begin playback of a familiar music or film source.
2. Listen from the primary listening position, increasing volume to a comfortable level.
3. Experiment with the loudspeakers' placement to achieve the best overall tonal balance, stereo image precision, and sense of spaciousness in the listening room. Refer to the Installation Considerations section on page 5 for additional information about loudspeaker placement.

CARING FOR YOUR LOUDSPEAKERS

GRILLES

Revel PerformaBe speakers feature grilles with a magnetic attachment method that eliminates unsightly attachment hardware from the speaker baffle, so if you decide to use your speakers with the grilles removed they will retain their elegant appearance.

F328Be

When installing the grilles on the F328Be speakers, orient them so that the "TOP" markings (embossed in the ears of the grille frames) are towards the tops of the speaker cabinets

CABINET FINISH

The cabinet's wood veneer or lacquer finish does not require routine maintenance. Cabinet surfaces that have been marked with dust, fingerprints, or other dirt can be cleaned using a soft cloth - preferably micro-fiber, and high quality auto wax. Take care not to come in contact with the transducers.

- To clean the grille, gently vacuum it using a soft-bristled brush vacuum attachment with the vacuum cleaner set to the lowest possible suction.

CAUTION: To prevent cabinet damage, do not use a cloth made with steel wool or metal polish to clean the cabinet. To prevent possible transducer damage, do not apply furniture polish directly to the cabinet

CAUTION: BERYLLIUM TWEETER CAUTION

Beryllium dust is a hazardous material. The Revel PerformaBe Beryllium dome will not emit any dust under normal circumstances and is perfectly safe unless it is damaged. The tweeter dome is protected by the acoustic lens and waveguide. As long as the waveguide remains intact there is no cause for concern. In the unlikely event that the dome is damaged in any way, cover the tweeter with adhesive plastic tape and contact Revel for further instructions. Do not play the speaker if it has a damaged tweeter dome.

At the end of the speaker's life do not dispose of it in a landfill or incinerator. Bring the speaker to an appropriate recycling or hazardous waste disposal site. Please contact Revel customer service for more information about proper disposal.

SPECIFICATIONS

Type:	3-way triple 8" floorstanding loudspeaker
Low-frequency transducer:	Three 8" (203mm) Deep Ceramic Composite(DCC) aluminum cone, with cast frames
Midrange transducer:	5-1/4" (130mm) Deep Ceramic Composite(DCC) aluminum cone, with cast frame
High-frequency transducer:	1" (25mm) Beryllium dome, with acoustic lens waveguide
Recommended amplifier power range:	50 - 400 watts
Frequency response:	26 Hz- 40 kHz (-6dB)
Low-frequency extension:	24Hz (-1 OdB); 26Hz (-6dB); 35Hz (-3dB)
Nominal impedance:	8 ohms
Sensitivity (2.83V/1 m):	91 dB
Crossover frequencies:	240Hz; 2.1 kHz
Enclosure type:	Bass-reflex via front-mounted port
Inputs:	Dual pair gold-plated binding posts with shorting straps
Dimensions (H x W x D, grille and base included):	50.9" X 13.5" X 17.6" (1294mm x 341.3mm x 448.5mm)
Product Weight (grille included):	112.59 lb (51.07 kgs)

LIMITED WARRANTY

Revel loudspeakers are warranted against defects. The duration of a warranty depends on the laws in the country in which it was purchased. Your local Revel retailer can help you determine the duration and coverage of your warranty.

For more information please visit: REVELSPEAKERS.COM

Please visit REVELSPEAKERS.COM for additional language support on the user manual.

Veuillez visiter REVELSPEAKERS.COM pour obtenir le mode d'emploi en d'autres langues.

Если вам требуется дополнительные версии руководства пользователя на других языках, посетите сайт REVELSPEAKERS.COM.

別の言語に対応したユーザーマニュアルを読むには、REVELSPEAKERS.COMにアクセスしてください。

사용자 설명서에 대한 추가 언어 지원은 REVELSPEAKERS.COM에서 확인하십시오
请访问 REVELSPEAKERS.COM 以获取其他语言版本的用户手册。

Visita REVELSPEAKERS.COM para obtener el manual de usuario de soporte en idiomas adicionales.

Weitere Sprachfassungen der Bedienungsanleitung findest Du unter REVELSPEAKERS.COM.

Торговая марка:	Revel
Назначение товара:	Пассивная акустическая система
Изготовитель:	Харман Интернешнл Индастриз Инкорпорейтед, США, 06901 Коннектикут, г.Стэмфорд, Атлантик Стрит 400, офис 1500
Страна происхождения:	Китай
Импортер в Россию:	ООО "ХАРМАН РУС СиАйЭс", Россия, 127018, г.Москва, ул. Двинцев, д. 12, к 1
Гарантийный период:	1 год
Информация о сервисных центрах:	www.harman.com/ru тел. +7-800-700-0467
Срок службы:	5 лет
Товар сертифицирован:	EAC
Дата производства:	Дата изготовления устройства определяется по двум буквенным обозначениям из второй группы символов серийного номера изделия, следующих после разделительного знака «-». Кодировка соответствует порядку букв латинского алфавита, начиная с января 2010 года: 000000-МУ0000000, где «М» - месяц производства (А - январь, В - февраль, С - март и т.д.) и «У» - год производства (А - 2010, В - 2011, С - 2012 и т.д.).

产品中有害物质的名称及含量

部件名称	目标部件	有害物质或元素					
		铅(Pb)	汞(Hg)	镉(Cd)	六价铬(Cr(VI))	多溴联苯(PBB)	多溴二苯醚(PBDE)
电路板	印刷电路板, 电路板上的电子零件 (不包括特定电子零件), 内部相关连接线	X	0	0	0	0	0
箱体	外壳, 面板, 背板等	X	0	0	0	0	0
特定电子零部件	变压器, 保险丝, 大型电解电容, 电源插座	X	0	0	0	0	0
附件	电线, 说明书, 包装等	X	0	0	0	0	0

本表格依据SJ/T 11364的规定编制

0: 表示该有害物质在该部件所有均质材料中的含量均在GB/T 26572 规定的限量要求以下。

X: 表示该有害物质至少在该部件的某一均质材料中的含量超出GB/T 26572规定的限量要求。



在中华人民共和国境内销售的电子电气产品上将印有“环保使用期”(EPUP)符号。圆圈中的数字代表产品的正常环保使用年限。



HARMAN International Industries, Incorporated
8500 Balboa Boulevard, Northridge, CA 91329 USA

© 2019 HARMAN International Industries, Incorporated. All rights reserved.

Revel and the Revel logo are trademarks of HARMAN International Industries, Incorporated, registered in the United States and/or other countries.

All Rights Reserved. Features, specifications and appearance are subject to change without notice.

For questions, assistance or additional information concerning any of our products, call us at: (516) 594-0300 or (888) 691-4171. For technical support, submit your detailed inquiry to: csupport@harman.com.



Part No. 950-0573-001

REVEL®

www.revelspeakers.com