

NT300 ELECTRIC OUTBOARD MOTOR OWNER'S MANUAL

# NEWPORT®



## NT300

ELECTRIC OUTBOARD MOTOR  
OWNER'S MANUAL

THE WAY FORWARD IS **ELECTRIC**





## Leading Innovator of **NEXT-GENERATION ELECTRIC Fishing Systems**

Newport is the leading innovator in next-generation electric small boat systems, providing anglers with powerful, reliable, and hassle-free solutions for over a decade.

From cutting-edge electric motors and high-performance lithium batteries to durable, purpose-built boats, Newport delivers a complete system designed for seamless integration and peak performance on the water.

Built for anglers who demand efficiency and reliability, Newport eliminates the noise, maintenance, and hassle of traditional setups so you can focus on what matters.

**THE WAY FORWARD IS ELECTRIC.**

Visit [newportvessels.com](https://newportvessels.com) ▶

**NEWPORT**

 (866) 721-0002

 support@newportvessels.com

 newportvessels.com



# CONTENTS

1 General Information	4
<b>1.1 Product Identification</b>	<b>4</b>
2 Technical Data	4
3 Safety Information	5-6
<b>3.1 Critical Safety Information</b>	<b>5-6</b>
<b>3.2 Before Use</b>	<b>5</b>
<b>3.3 During Use</b>	<b>5</b>
<b>3.4 After Use</b>	<b>6</b>
4 Installation	6-7
<b>4.1 Install the Motor in the Boat</b>	<b>6</b>
<b>4.2 Adjusting the Trim</b>	<b>6-7</b>
<b>4.3 Fixing the Steering</b>	<b>7</b>
<b>4.4 Connect to the Battery</b>	<b>7</b>
5 Controller Display	8-10
<b>5.1 Overview of Multi-Function Display</b>	<b>8</b>
<b>5.2 Battery Display</b>	<b>8</b>
5.2.1 Estimated Percent of Remaining Battery Power	8
5.2.2 Switching Between Battery Types	9
<b>5.3 Error Status Display</b>	<b>9</b>
<b>5.4 Error Codes and Solutions</b>	<b>10</b>

6 Operation	10-12
<b>6.1 Start the Motor</b>	<b>10</b>
<b>6.2 Travel Forward/Reverse</b>	<b>10</b>
<b>6.3 Steering the Motor</b>	<b>11</b>
<b>6.4 Emergency Stop</b>	<b>11</b>
<b>6.5 Finishing the Trip</b>	<b>11</b>
<b>6.6 Stow the Motor</b>	<b>12</b>
<b>6.7 Deploy the Motor</b>	<b>12</b>
7 Care and Services	12-15
<b>7.1 Care of Motor Components</b>	<b>12</b>
<b>7.2 Corrosion Protection</b>	<b>13</b>
<b>7.3 Care of Battery Usage</b>	<b>13</b>
<b>7.4 Replacing the Fin</b>	<b>13</b>
<b>7.5 Replacing the Propeller</b>	<b>14</b>
<b>7.6 Recalibrate the Throttle</b>	<b>14-15</b>
Declaration of Conformity for Recreational Craft	15
Customer Support	15



**Please read and retain this manual before using this electric motor.** This manual contains information that describes the procedure for safe operation and daily maintenance of your electric motor. Safe operation will prevent personal injury and damage to the product.

## 1 GENERAL INFORMATION

Thank you for purchasing the **NT300 Electric Outboard**. We hope that you enjoy it!

The Newport NT300 Electric Outboard is designed with direct-drive and field-oriented-control technology to deliver the ultimate efficiency in a compact package. The propulsive power of the NT300 is equivalent to a 3hp petrol outboard motor but with silent and emission-free power delivery.

The Newport NT300 Electric Outboard is compatible with conventional 36V deep cycle batteries, 36V LFP lithium battery, and 36V lithium cobalt oxide.

**Please read and retain this manual before using this electric motor.** This manual contains information that describes the procedure for safe operation and daily maintenance of your electric motor. Safe operation will prevent personal injury and damage to the product.

### 1.1 PRODUCT IDENTIFICATION

Check the figure below to find the serial number of your product. You will need this as a reference to access after-sale services.

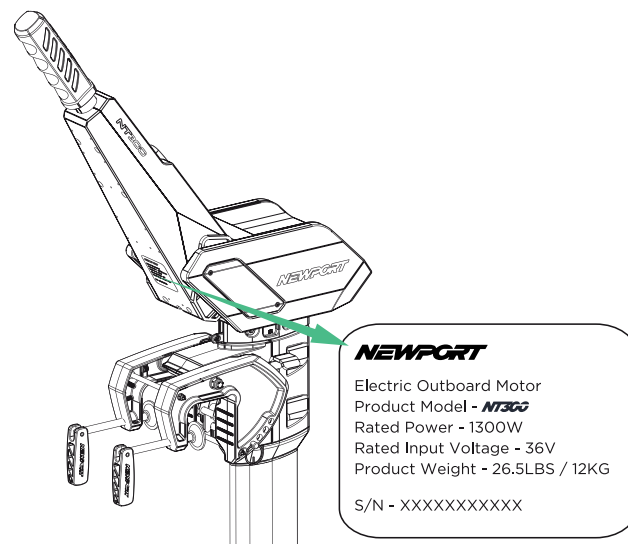

## 2 TECHNICAL DATA

<b>Rated Input Power(static)</b>	1300W
<b>Comparable Petrol Outboard</b>	3HP
<b>Battery Type</b>	Deep Cycle Marine Battery LFP Lithium Battery Lithium Cobalt Oxide Battery
<b>Battery Input Voltage</b>	36V-Deep Cycle Marine Battery 36V-LFP Lithium Battery 36V-Lithium Cobalt Oxide Battery
<b>Max. Overall Efficiency</b>	50%
<b>Rated Rotation Speed</b>	1500 rpm
<b>Total Weight</b>	Short: 23.8lbs (10.8kg) Long: 24.3 lbs (11kg)
<b>Shaft Length</b>	Short: 25in (635mm) Long: 30in (760mm)
<b>Control System</b>	Digital Control/Integrated Tiller
<b>Tilt Angle</b>	Manual, 80°
<b>Trim Angle</b>	Manual, 0°, 7°, 14°, 21°
<b>Propeller Diameter</b>	10.6 in (270mm)

## 3 SAFETY INFORMATION

### 3.1 CRITICAL SAFETY INFORMATION

Please read all safety information before installing or operating your electric motor. Severe injury, damage, or even death can occur as a result of improper usage.

**⚠ WARNING:** There is a risk of death or severe injury from electric shock- use caution and do not touch any uninsulated wires or damaged parts.

- Do not use damaged batteries.
- If wiring is frayed or broken, do not touch it.
- If repair work is needed to the electrical components of your product, do not attempt to do it yourself.
- If there is any problem with the system, turn off the power immediately and avoid touching the metal components.

**⚠ WARNING:** There is a risk of explosion which could result in death, serious injury, or property damage due to the production of oxyhydrogen gas from the battery.

- If the battery becomes submerged in water deeper than one meter for a short period of time, do not attempt to recover the battery, and refer to the safety instructions provided by the battery manufacturer.
- If the battery has been submerged in shallow water, less than a meter, for more than 30 minutes, do not attempt to recover the battery, and refer to the safety instructions provided by the battery manufacturer.

**⚠ WARNING: Electromagnetic radiation may cause death or severe injuries to people with cardiac pacemakers. Those with pacemakers should not get too close to the motor and should consult their physician about the proper distance for safety.**

**⚠ WARNING:** There is inherent danger in using a boat - always prepare for the unexpected. A boat which is out of control can easily result in severe injuries or death by drowning.

Always check weather predictions and water conditions before a trip on the water, and also familiarize yourself with a map of the area you'll be traversing.

Depending on the size of your boat, make sure you bring any proper safety equipment. Paddle(s) and a communication device are a must for any size of boat, and if appropriate, also bring an anchor and extra drive.

Always check your motor and system for any damage and ensure they are running properly before leaving the dock.

**⚠ WARNING:** Use caution around rotating components to avoid possible injury or even death.

- Do not wear loose clothing or jewelry near the motor shaft or propeller and tie up long hair.
- Never attempt maintenance or cleaning of the motor shaft or propeller without first shutting off the system.
- Power down the motor when there are people too near the propeller or motor shaft.
- Do not use the propeller out of the water.

**ⓘ CAUTION:** Batteries can cause severe physical harm or even death in many different ways. Always read and follow all safety even death in many different ways. Always read and follow all safety guidelines and instructions provided by your battery manufacturer.

- Never use third-party chargers for batteries, it could start a fire.
- If the battery catches fire during use, use water to cool the battery and prevent fire from spreading; however water will not extinguish a lithium fire - if possible, use sand to smother the fire.

**ⓘ CAUTION:** Parts may be hot enough to cause burns. Do not touch the components or battery immediately after use; allow to cool sufficiently before handling the components.

**ⓘ CAUTION:** Danger of crushing when tilting the motor- keep fingers, hands, and all body parts away from the mechanical parts and the area of the motor when tilting the motor.

### 3.2 BEFORE USE

- This motor should only be operated by an adult who has thorough understanding and command of the motor, including steering functions, emergency stop switch, and throttle.
- Always operate your boat and this motor in compliance with local safety regulations.
- Always carry a paddle on board at all times, especially when using an electric motor as your primary method of propulsion.
- All passengers should wear approved life jackets at all times.
- Check the status and condition of your motor and battery before each trip. We recommend starting every trip with a full battery charge.
- Do not operate the motor outside of the water.
- Do not modify the motor with non-original parts.

### 3.3 DURING USE

- Stop the motor immediately if someone is over board.
- Propellers are dangerous- use extra caution when operating the motor near areas where people may swim. Always be alert and aware of your surroundings when operating the motor.
- Do not exceed the recommended load and power limitations of your boat as suggested by its manufacturer.

### 3.4 AFTER USE

- Disconnect the motor from the battery after use.
- Rinse the motor carefully with freshwater after each usage, especially after use in saltwater.

Do not carry the kayak/boat by lifting with the bracket. This can cause damage to the boat and potentially to the bracket.

## 4 INSTALLATION

### 4.1 INSTALLATION OF THE BRACKET

Place the motor on the transom of the boat.

**Note:** It's suggested to mount the motor at the centerline of the boat for better steering experience.

1. Place the motor on the transom of the boat.  
**Note:** It's suggested to mount the motor at the centerline of the boat for better steering experience.

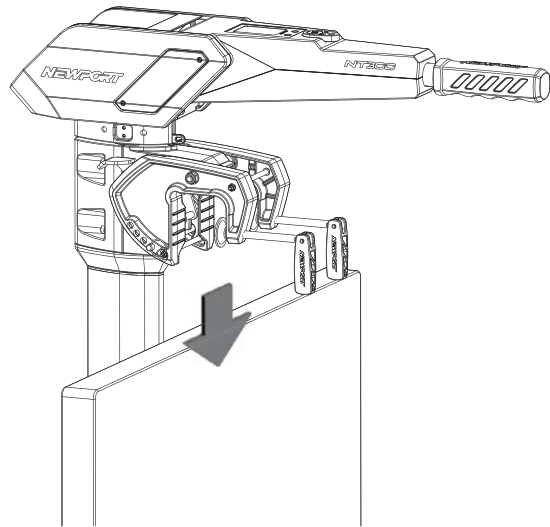

2. Tighten the clamp handles to fix the motor on the transom of the boat.

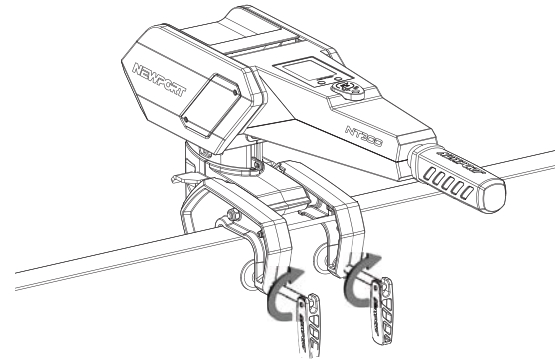

### 4.2 ADJUSTING THE TRIM

Adjust the motor's trim according to the boat type to get the optimal position relative to the water surface for better running speed.

**! Advice:** It's recommended to try out different trim angles to have the best performance and highest efficiency.

**! CAUTION:** Make sure the motor is fully stopped before adjusting the trim angle.

1. Make sure the reverse lock is pulled up.

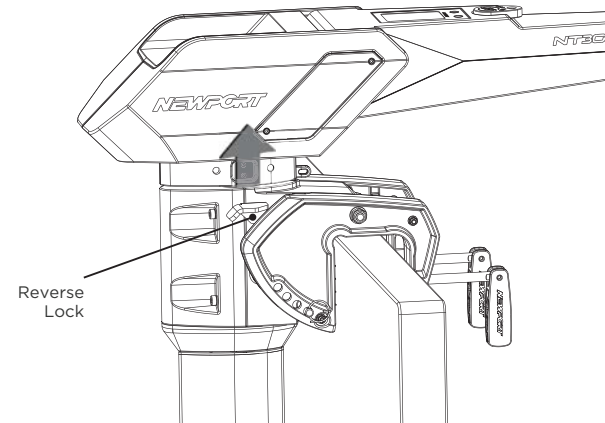

2. Remove the stop ring and pull out the trim pin.

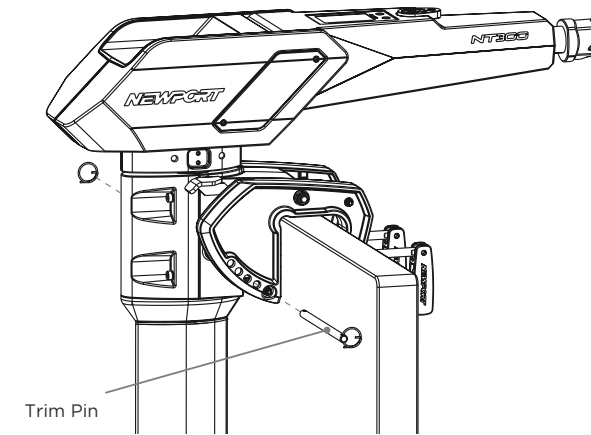

3. Lift the motor to the stow position.

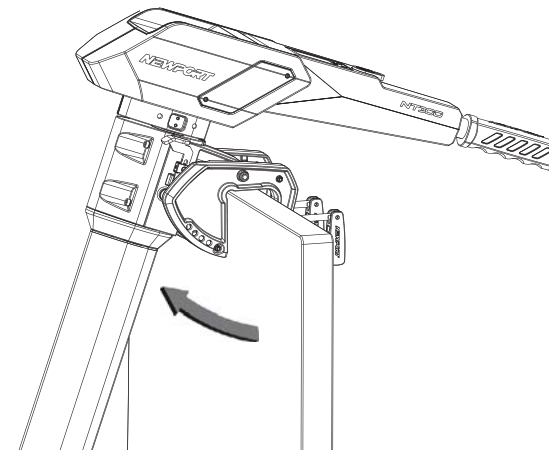

Insert the trim pin to select the desired trim angle, install the stop ring and deploy the motor again.

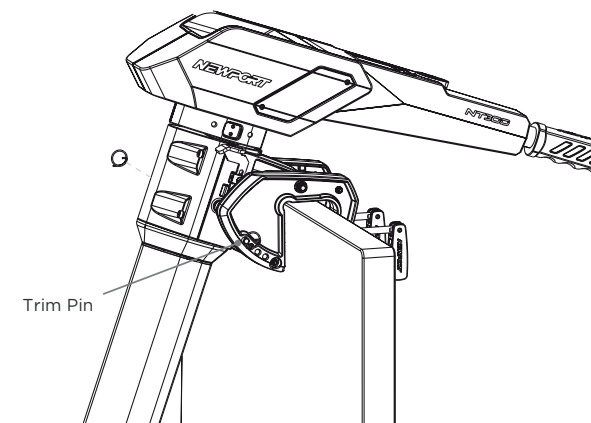

### 4.3 FIXING THE STEERING

1. To stop the motor from steering, place the lock pin into the hole.

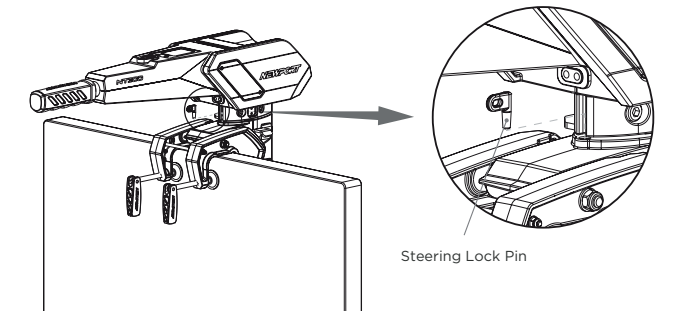

2. With the lock pin inserted in the hole, now the steering of the motor is fixed. You can use other methods (rudder for example) to steer the boat.

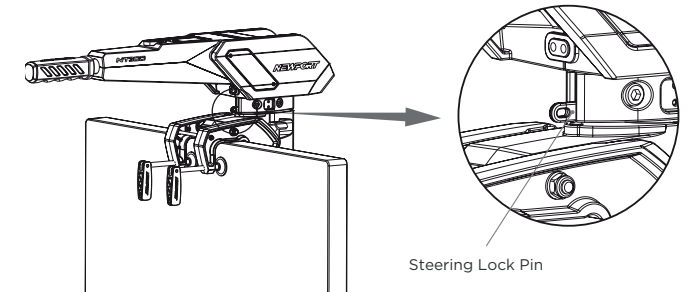

### 4.4 CONNECT TO THE BATTERY

The motor is adaptable with 36V (three 12V batteries connected in series) deep cycle marine battery package, 36V LFP lithium battery (including three 12V LFP lithium batteries connected in series) and 36V lithium cobalt oxide battery package. Please follow the steps below to complete the battery connection.

1. Find the battery cables from the motor; there should be a red and a black cable.
2. Connect the red cable to the positive battery terminal and the black cable to the negative battery terminal.
3. Make sure the battery cables are connected to the correct terminal. The motor will not operate if battery cables are installed incorrectly.
4. Tighten the connection of the battery cables to the battery terminals. Make sure the connection is solid and secure.

**⚠ WARNING:** Be sure all switches are in the OFF position before connecting to battery or batteries. Electrical arcing near the battery could cause an explosion. The battery produces hydrogen and oxygen gases while charging. This potentially explosive mixture escapes through the fill vent cell caps and may form an explosive atmosphere around the battery for several hours after it has been charged. Electrical arcing or flames can ignite the gas and cause an explosion, which may shatter the battery and could cause blindness or other serious injury.

**⚠ WARNING:** Deep cycle Batteries contain sulfuric acid, which can cause severe burns. Avoid contact with skin, eyes and clothing.

## 5 CONTROLLER DISPLAY

### 5.1 OVERVIEW OF MULTI-FUNCTION DISPLAY

The speed controller screen features motor and battery information for the operator to monitor. There are two buttons on the speed controller to control the motor.

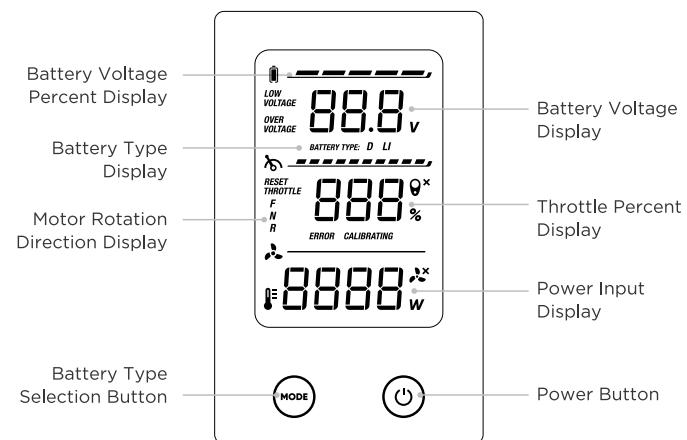

### 5.2 BATTERY DISPLAY

The speed controller screen features motor and battery information for the operator to monitor. There are two buttons on the speed controller to control the motor.

#### 5.2.1 ESTIMATED PERCENT OF REMAINING BATTERY POWER

The battery bar has 6 different status levels to display the estimated remaining battery percentage.

### 5.2 BATTERY DISPLAY

The speed controller screen features motor and battery information for the operator to monitor. There are two buttons on the speed controller to control the motor.

#### 5.2.1 ESTIMATED PERCENT OF REMAINING BATTERY POWER

The battery bar has 6 different status levels to display the estimated remaining battery percentage.

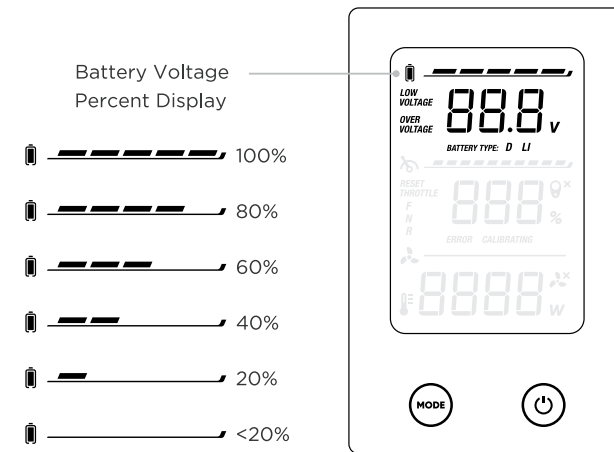

**ⓘ CAUTION:** Do not overestimate the remaining battery range; this could result in severe harm or even death.

- Before you leave the dock, know the area you are traveling, how far you plan to go, and make sure to have an alternate plan for safely getting back if anything goes wrong with your motor or battery. Always bring a paddle.
- Monitor the battery level indicator during your trip and always leave a buffer for getting back to shore.

### 5.2.2 SWITCHING BETWEEN BATTERY TYPES

This motor can run on a 36V deep cycle battery setup, a 36V LFP lithium battery setup, or a 36V lithium cobalt oxide battery.

You will need to select which type of battery you are using with your motor for accurate results on the LCD screen. When the battery is connected to the motor, press the MODE button to toggle between the Li (LFP Lithium Battery or Lithium Cobalt Oxide Battery) or D (Deep Cycle Battery) battery options.

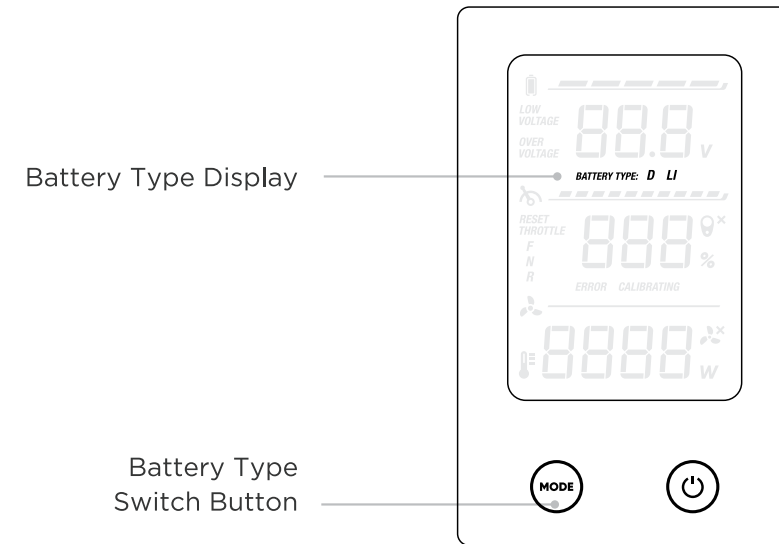

### 5.3 ERROR STATUS DISPLAY

The icons indicated on the LCD screen above show three possible error statuses of the motor. When a fault occurs, there will be a corresponding code on screen to help diagnose the problem. See section 5.4 Error Codes and Solutions.

**Motor overvoltage:** If the input voltage is too high, this icon will light up and keep flashing. Please make sure the input voltage to the motor is correct (24V or 25.9V). Ensure the correct battery option is selected (D or Li).

**Motor overheated:** If the motor driver PCB is over heated, this icon will light up.

**Motor stalled:** If the motor is stalled, this icon will light up. Please disconnect from the battery and check to see if the propeller has been tangled in weeds or fishing line- these can also get wrapped behind the propeller. Clean the propeller and resume running.

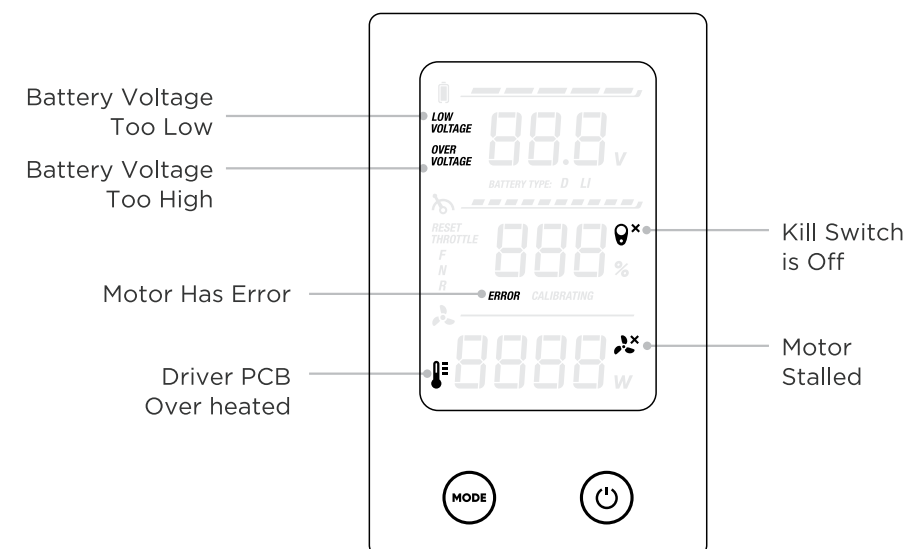

## 5.4 ERROR CODES AND SOLUTIONS

If there is an issue with the motor function, the display will show an error code to help diagnose the problem and find the solution. Scan the QR code below to access the Error Code Reference Guide.

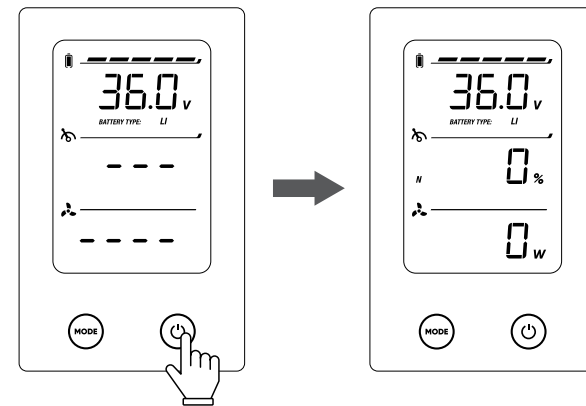
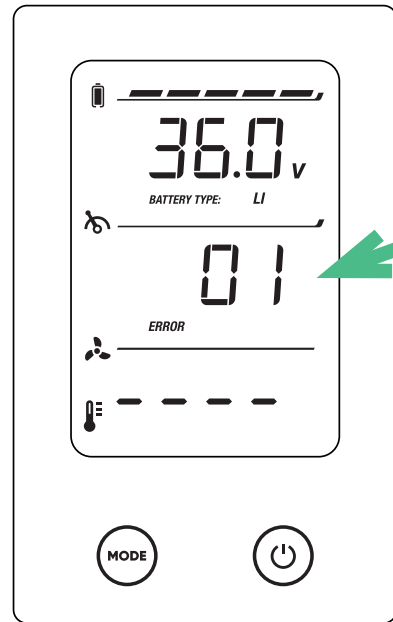

## 6 OPERATION

### 6.1 START THE MOTOR

To start the motor please follow the steps below:

1. Place the magnet kill switch on the tiller.
2. Select the battery mode according to the battery type used. Please follow **5.2.2 Switching Between Battery Types** to operate correctly.
3. Press the power button on the panel.
4. You can now begin to power your motor.

### 6.2 TRAVEL FORWARD/REVERSE

The motor's forward/reverse motion is controlled by the handle of the tiller. Please refer to the diagram below which demonstrates how to operate.

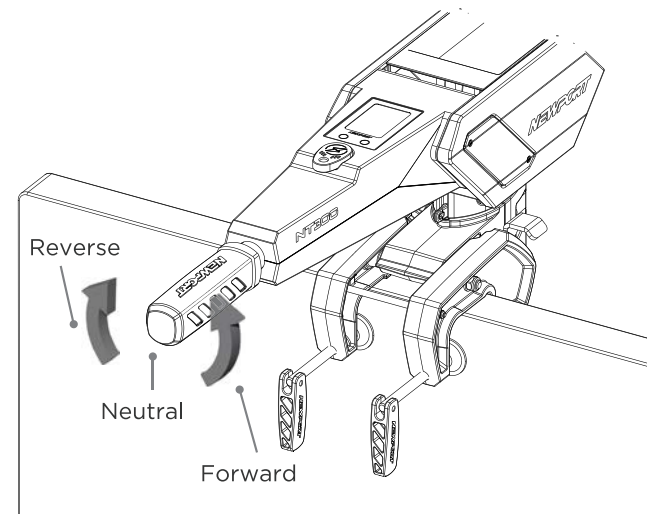

When switching to reverse, make sure to push the reverse lock to lock the bracket.

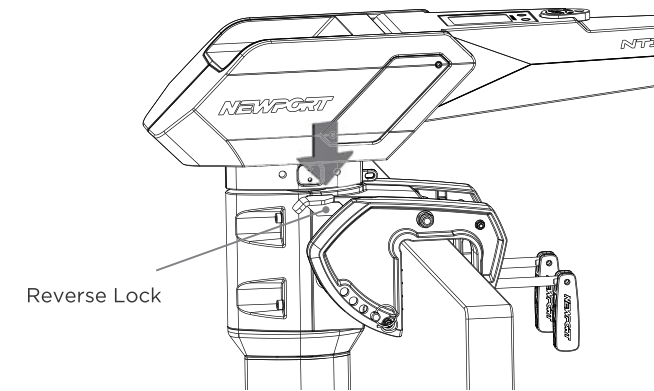

### 6.3 STEERING THE MOTOR

While the motor is operating, steer the tiller to control the boat's direction.

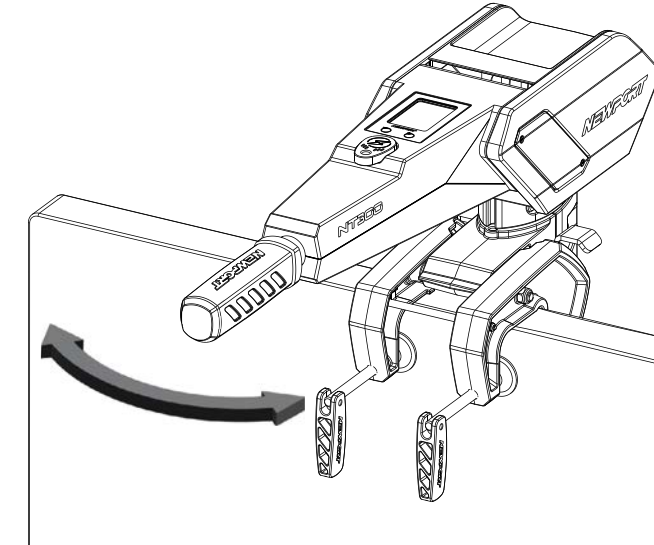

## 6.4 EMERGENCY STOP

To stop **immediately** you can:

- Pull off the magnetic emergency stop switch from the tiller to stop the motor.
- Move the handle of the tiller to the neutral position to stop the motor.

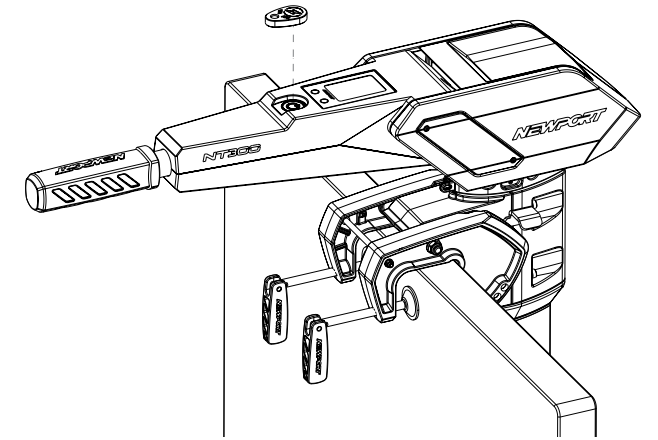

If you want to restart the motor after the emergency kill switch is pulled off, move the handle of tiller to the neutral position, return the kill switch, and power on.

To stop the motor, follow the steps below:

1. Move the handle of tiller to the neutral position.
2. Press the On/Off button on the speed controller.

Remove the emergency kill switch.

### 6.5 FINISHING THE TRIP

When the trip is finished, disconnect the motor from the battery and take the motor out of water. If the motor was used in the saltwater, thoroughly rinse the motor with fresh water. This will help prevent corrosion and salt buildup. Only wash the motor; do not get the speed controller wet.

## 6.6 STOW THE MOTOR

When needed, the motor can be tilted up to stow away or to avoid underwater obstacles. Before lifting the motor up make sure the reverse lock is lifted up. **NOTE:** It's recommended to keep the reverse lock unlocked (lifted) when the motor drives forward since motor will be kicked up automatically with this setup.

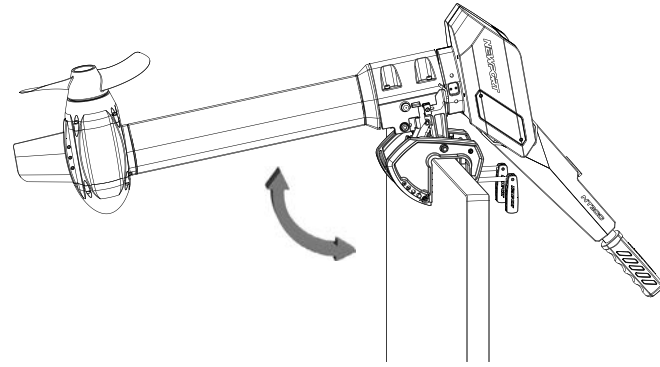

**1 Advice:** The tilt support device supplied on your outboard is not intended for towing. It is intended to support the engine while the boat is docked, beached, etc. It is recommended to remove the motor during transport or use a motor support bracket/transom saver.

## 6.7 DEPLOY THE MOTOR

To deploy the motor again, follow the steps below:

1. Lift the motor up.

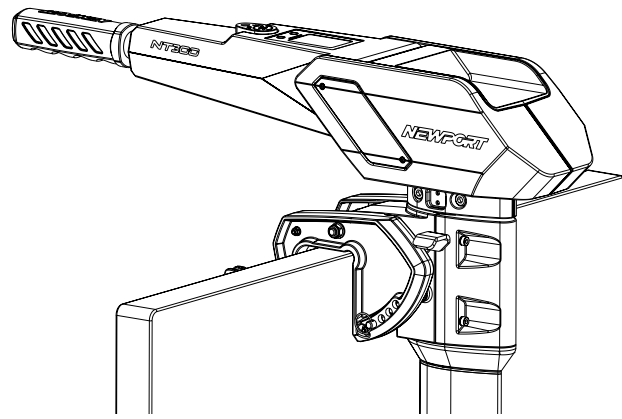
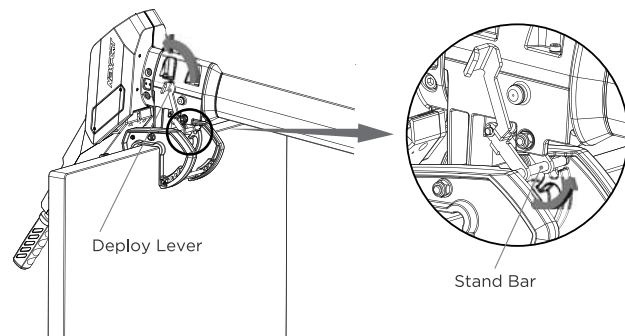

2. Lift the deploy lever up. Make sure the stand bar is out of the slot.
3. Tilt the motor down slowly until the trim pin is hit again.

## 7 CARE AND SERVICES

### 7.1 CARE OF MOTOR COMPONENTS

- Please regularly follow all maintenance tips to keep your motor in optimal working condition.
- Do not start the motor in shallow water as it may damage the propeller.
- After each use, check between the plastic propeller and metal motor housing for fishing line, weeds, or other debris. **ALWAYS DISCONNECT** from power before working near the propeller.
- Lubricate all the pivot points with a non-aerosol lubricant. Never use an aerosol lubricant, as many types contain harmful propellants that can cause damage to various parts of your electric motor.

### 7.2 CORROSION PROTECTION

- After the motor is used in the saltwater, rinse the motor thoroughly with fresh water.
- Before storing the motor, make sure the motor is completely dry and clean.
- Keep cable connectors and plugs in good condition.
- Use a wire brush to remove corrosion when necessary.

### 7.3 CARE OF BATTERY USAGE

- Check tightness of the battery lead connections.
- Never connect the wires to the wrong battery terminal. You must disconnect the battery during maintenance.
- Recharge batteries after each use. Follow the battery manufacturer's recommendations for battery maintenance.

### 7.4 REPLACING THE FIN

You can replace the fin component if it is damaged. To do this, follow the steps below:

1. Release the three M3 screws and nuts.

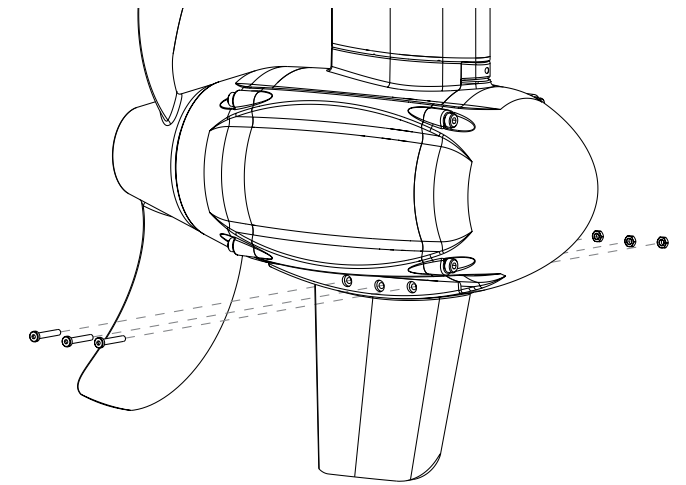

2. Remove the old fin component.
3. Insert the new fin component.
4. Insert three M3 screws and tighten them.

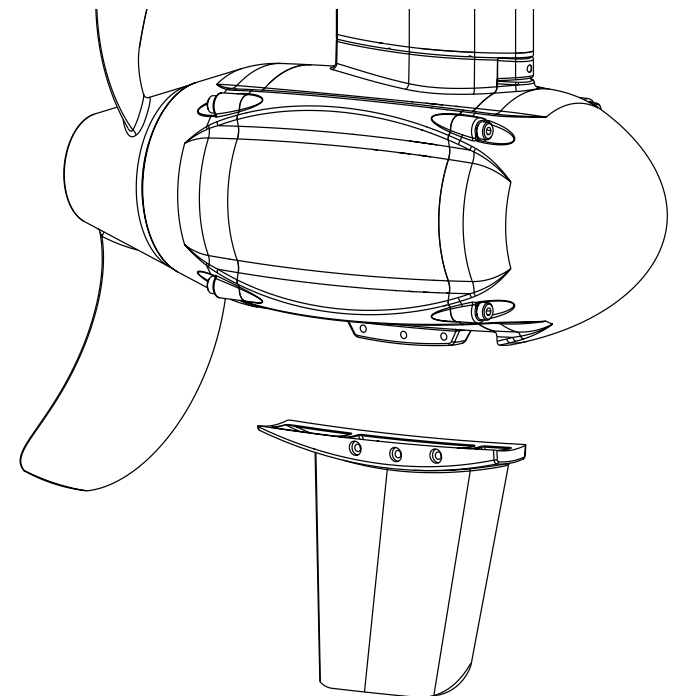

### 7.5 REPLACING THE PROPELLER

You can replace the propeller if it is damaged. To do this, follow the steps below with the assembly diagram:

1. Attach the washer.
2. Insert the drive pin into the hole on the motor output shaft.
3. Rotate the propeller until the drive pin is seated correctly in the corresponding channel on the backside of the propeller.
4. Place the washer on the motor shaft after the propeller.
5. Tighten the hex locknut with 17mm socket wrench.

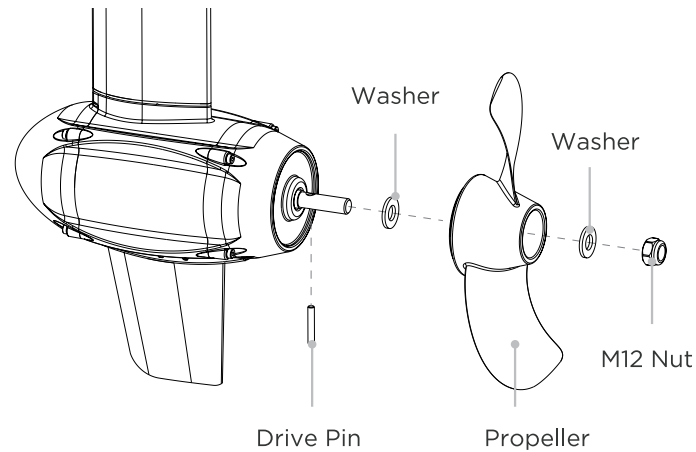

### 7.6 RECALIBRATE THE THROTTLE

You can recalibrate the throttle when the throttle display is inaccurate. To do this, follow the steps below:

1. Press and the MODE button for 5 seconds, the controller will enter the throttle recalibration mode. You will notice the CALIBRATING sign starts to flash.
2. While the screen displays the F icon, move the handle to the full throttle forward position.
3. Press the MODE button again.

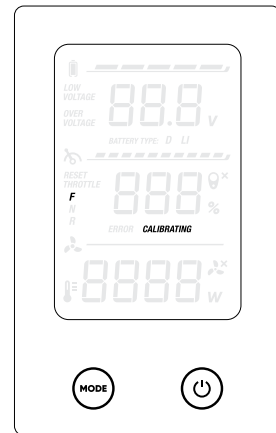

1. While the screen displays the R icon, move the handle to the full throttle reverse position.
2. Press the MODE button again

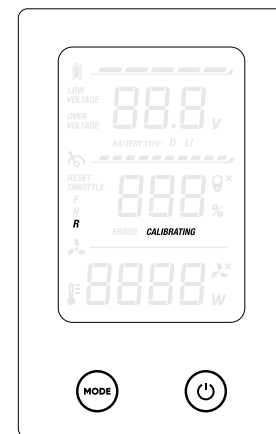

1. While the screen displays the N icon, move the handle to the Neutral (middle) position.
2. Press the MODE button again. And the throttle recalibration is complete. You will notice the CALIBRATING sign stops to flash, press the POWER button to exit the recalibration mode.
3. When the CALIBRATING sign flashes, it means the recalibration is not finished yet, exiting the throttle recalibration mode will not change the current throttle setup.

To exit the throttle recalibration mode at any steps during the process, press the POWER button.

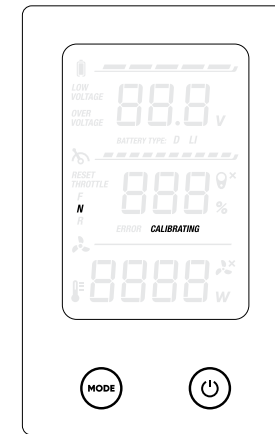

### DECLARATION OF CONFORMITY FOR RECREATIONAL CRAFT

Propulsion Engine with the requirements of Directive 89/392/EEC as amended by 89/336/EEC.

Engine type approved according to:

Directives 89/392/EEC, 89/336/EE

Description of Engine(s) and Essential Requirements

Engine Type: Outboard Engine

Fuel Type: Electric

This declaration of conformity is issued under the sole responsibility of the manufacturer. I declare on behalf of the manufacturer that the motor(s) is (are) in conformity with the type(s) for which above mentioned EC, EMC and ROHC type-examination or type approval certificate(s) has (have) been issued and it will meet the requirements of Directive 89/392/EEC, 89/336/EEC as amended when installed in a recreational craft, in accordance with the manufacturer's supplied instructions.

### CUSTOMER SUPPORT

If you have questions that are not answered in this manual or troubleshooting is not successful, please contact Newport! Our California based customer service team is standing by to assist you. **8:30 AM - 7:00 PM ET**

(866) 721-0002

support@newportvessels.com

newportvessels.com

Bluetooth  
Lithium Battery

NS130 Inflatable Skiff  
Complete Package

Tiller Extension  
Handle

LoPRO Lithium  
Battery

NT300 Electric  
Outboard Motor

**THE WAY FORWARD IS  
WITH ACCESSORIES**

**NEWPORT**®

Newport designs innovative accessories crafted to elevate your time on the water, propelling you further.

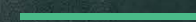

# NEWPORT®



**SHARE YOUR  
ADVENTURES**

**@newportvessels**

**THE WAY FORWARD IS ELECTRIC**



REV FX02X259