



Poly Sync 10 Series Corded Speakerphone User Guide

SUMMARY

This guide provides the end-user with task-based user information for the featured product.

Legal information

Copyright and license

© 2026, HP Development Company, L.P. The information contained herein is subject to change without notice. The only warranties for HP products and services are set forth in the express warranty statements accompanying such products and services. Nothing herein should be construed as constituting an additional warranty. HP shall not be liable for technical or editorial errors or omissions contained herein.

Trademark credits

All third-party trademarks are the property of their respective owners.

Privacy policy

HP complies with applicable data privacy and protection laws and regulations. HP products and services process customer data in a manner consistent with the HP Privacy Policy. Please refer to [HP Privacy Statement](#).

Open source software used in this product

This product contains open source software. You may receive the open source software from HP up to three (3) years after the distribution date of the applicable product or software at a charge not greater than the cost to HP of shipping or distributing the software to you. To receive software information, as well as the open source software code used in this product, contact HP by email at ipgoopensourceinfo@hp.com.

Table of contents

Controls and status lights	1
LEDs	1
Be safe	2
Setup	3
Corded setup	3
Load software	3
Update your Poly device	4
Basics	5
Power	5
Answer or end a call	5
Make a call	5
Hold call	5
Adjust volume	5
Adjust speakerphone microphone volume	6
Mute/Unmute	6
Launch Microsoft Teams (Teams model only)	6
Troubleshoot	7
What's in the box	8
Safety warnings	9
Safety Instructions	9
Support	11



Controls and status lights

A portable speakerphone with corded connectivity.

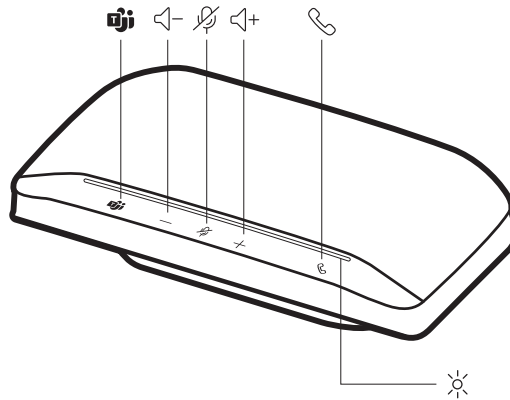

Icon	Description
	Press to interact with Microsoft Teams (Teams model only, desktop application required)
	Volume down
	Mute / Hold
	Volume up
	Call
	LED bar

LEDs

LED bar	What lights mean
Flashing green	Incoming call
Solid green	In a call
Solid red	Mute active
Flashing red	Call on hold

NOTE: LEDs do not illuminate in standby mode.



Be safe

Please read the safety guide for important safety and regulatory information before using your new device.



Setup

Corded setup

- Connect the USB cable from the speakerphone to the USB port on your computer.

 **NOTE:** Your speakerphone has a USB-A to USB-C adapter for easy connection to either type of port.

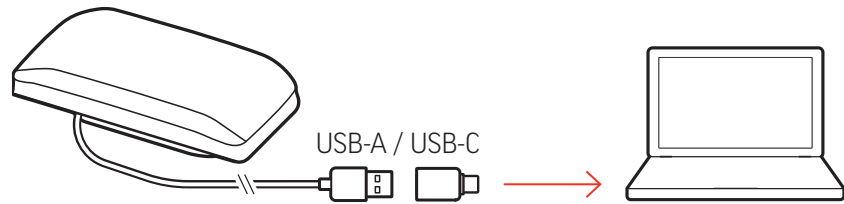

Load software

Download HP Poly Studio to get the most out of your device. Some softphones require the installation of HP software to enable device call control (answer or end a call and mute) functionality.

 **NOTE:** Administrative privileges may be required to download the desktop application. If you don't have administrator privileges on your system, contact your system administrator.

- Download the HP Poly Studio Desktop app at hp.com/studio.

Table 21 Supported features

Feature	HP Poly Studio Desktop app
Configure call control for softphones	√
Change headset language	√
Enable features	√
Choose preferred Equalizer setting	√
Battery meter	√
Update device firmware	√
Manage notifications and alerts	√
Schedule wellbeing reminders	√
View user guide	√
FindMyHeadset	

Update your Poly device

Keep your firmware and software up-to-date to improve performance and add new features to your Poly device.

Update your device using HP Poly Studio. Download at hp.com/studio.



Basics

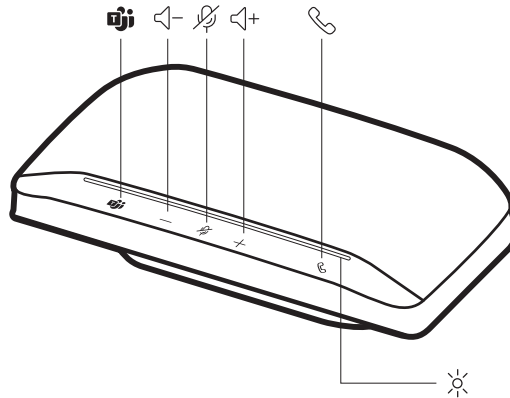

Power

Plug the USB cable into your computer. The LED bar illuminates when powered on.



NOTE: Your speakerphone has a USB-A to USB-C adapter for easy connection to either type of port.

Answer or end a call



- Press the Call  button to answer or end a call.

Make a call



Use your softphone to make an outgoing call.

- Dial using your softphone app.

Hold call

1. Press and hold the Mute  button for 2 seconds to hold the call. The LED bar flashes red.
2. To resume call, hold the Mute  button for 2 seconds. The LED bar returns to solid green.



NOTE: The Call  button is also equipped to hold calls. Press the Call  button for 2 seconds to hold/resume call.

Adjust volume

Adjust your speakerphone volume for calls, media, and notifications.

- **Call volume:** Press the volume up (+) or down (-) buttons when on a call (not streaming audio or idle).
- **Media streaming volume:** Press the volume up (+) or down (-) buttons when streaming media (not on a call or idle).



NOTE: Notification volume matches the media streaming volume. To adjust the notification volume, adjust the volume during media streaming.

Adjust speakerphone microphone volume

- Place a test softphone call and adjust softphone volume and PC sound volume accordingly.

Mute/Unmute

- During an active call, press the Mute  button to mute or unmute the microphones. Manage mute settings in HP Poly Studio Desktop.

Launch Microsoft Teams (Teams model only)

Your device has a Teams  button to quickly view and use the Microsoft Teams desktop app. The Teams button pulses when you have a meeting or notification.

- When not on a call, tap the Teams  button to view Microsoft Teams app on your computer.
- When the Teams button LED pulses purple, tap to view your Teams notifications or meeting.



NOTE: Teams model and open Teams desktop application required. Teams mobile application is not supported.



NOTE: If your Teams button is not responsive, ensure your Poly device is the default audio device in Microsoft Teams settings.

Troubleshoot

Issue	Resolution
(Teams model only) How do I interact with Microsoft Teams?	<ul style="list-style-type: none">• Tap the Teams  button to quickly open and use Microsoft Teams.• Teams model is compatible with Microsoft Teams desktop app. Teams mobile app is not supported.
(Teams model only) When I tap the Teams button nothing happens.	<ul style="list-style-type: none">• Your device is not set as the default audio input and output device in Microsoft Teams. Change settings in Microsoft Teams.
How do I manage my speakerphone using HP Poly Studio software?	<ul style="list-style-type: none">• Your speakerphone is supported by HP Poly Studio desktop application. Download: hp.com/studio.



What's in the box

Contents may vary by product.

Figure 5-1 Speakerphone with USB-A to USB-C adapter

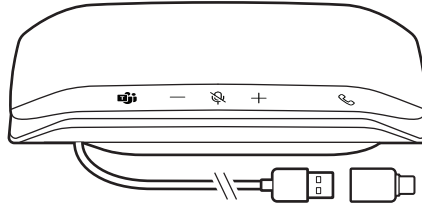

Figure 5-2 Quick start guide



Safety warnings

Safety Instructions

To reduce the risk of fire, electric shock, injury to persons and damage to property, read all operating instructions and the following safety instructions before using your HP product. Operating, storage and charging temperature is 10°C to 40°C (50°F to 104°F).

- Only use those HP products and accessories designed for use with this product.
- If you experience a skin irritation after using this product, discontinue use and contact HP.
- CHILDREN. Never allow children to play with the product-small parts may be a choking hazard.
- Do not disassemble the product as this may expose you to dangerous voltages or other risks. Incorrect reassembly can cause electric shock or fire when the product is subsequently used.
- Unplug, discontinue use and contact HP if the product overheats or has a damaged outer casing, cord or plug.
- Exposure to high volume sound levels or excessive sound pressure may cause temporary or permanent damage to your hearing. Although there is no single volume setting that is appropriate for everyone, you should always use your headset/headphones with the volume set at moderate levels and avoid prolonged exposure to high volume sound levels. The louder the volume, the less time is required before your hearing could be affected. You may experience different sound levels when using your headset/headphones with different devices. The device you use and its settings affect the level of sound you hear. If you experience hearing discomfort, you should stop listening to the device through your headset/headphones and have your hearing checked by your doctor. To protect your hearing, some hearing experts suggest that you:
 1. Set the volume control in a low position before putting your headset/headphones on your ears and use as low a volume as possible.
 2. Avoid turning up the volume to block out noisy surroundings. Whenever possible, use your headset/headphones in a quiet environment with low background noise.
 3. Limit the amount of time you use headsets/headphones at high volume levels.
 4. Turn the volume down if the sound from the headset/headphones prevent you from hearing people speaking near you.

- If you use your headset/headphones while driving, check local laws regarding use of a mobile phone and headset, and ensure your attention and focus remain on driving safely. Use of a headset/headphones that covers both ears will impair your ability to hear other sounds and in most regions is illegal to use while operating a motor vehicle or riding a bicycle and may be a serious hazard for you and others.
- If this product includes earbuds/eartips, install and use them in accordance with the instructions provided. Do not force earbuds/eartips down the ear canal. Consult a doctor if they become lodged in the ear canal.
- Plug the mains adapter or charger into a socket-outlet that is near to the equipment and will be easily accessible.

Battery Warnings for Wireless Products

- If your product has an embedded, non-replaceable battery, do not attempt to open the product or remove the battery as this may cause injury and/or damage the product. If your product has a replaceable battery, use only the battery type supplied by HP. Remove a spent battery promptly.
- Replace rechargeable batteries after three years or 300 charge cycles, whichever occurs first.
- Do not dispose of the product or battery in a fire or heat above 40°C (104°F).
- Do not expose the battery to extremely high temperatures. It may result in an explosion or the leakage of flammable liquid or gas.
- Do not open, deform or mutilate the battery. There may be corrosive materials which can cause damage to eyes or skin and may be toxic if swallowed.
- Never put batteries in mouth. If swallowed, contact a physician or poison control center.
- Swallowing may lead to burns, perforation of soft tissue, and death. Severe burns can occur within 2 hours of ingestion.
- Always store batteries where children cannot reach them.
- Do not allow any battery or its holder to contact metal objects such as keys or coins.
- RECYCLING: The product battery must be recycled or disposed of properly. Contact your local recycling center for battery removal and proper disposal.
- Use only the charger supplied by HP to charge the product and follow the charging instructions provided. Alternatively, if your headset is designed to be charged with your cell phone charger, use only cell phone chargers approved and provided by your cell phone manufacturer. Do not use the charger for any other purpose. Ensure that the voltage rating corresponds to the power supply you intend to use.

Support

NEED MORE HELP?

support.hp.com/poly

HP Inc.

1501 Page Mill Road
Palo Alto, CA 94304, U.S.A.
650-857-1501

HP REG 23010, 08028

Barcelona, Spain

HP Inc UK Ltd

Regulatory Enquiries, Earley West
300 Thames Valley Park Drive
Reading, RG6 1PT
United Kingdom

台灣惠普資訊科技股份有限公司

臺北市南港區經貿二路 66 號 10 樓
電話: 02-37899900

RMN (Regulatory Model Number): SY10/SY10-M USB-A/C. System: Poly Sync 10 has a SY10/SY10-M speakerphone.

