

**DRAPER**®

**D20**  
MULTI-TOOL BATTERY SYSTEM

GB

20V LI-ION 10L WET & DRY

# VACUUM CLEANER

98501



These instructions accompanying the product are the original instructions. This document is part of the product, keep it for the life of the product passing it on to any subsequent holder of the product. Read all these instructions before assembling, operating or maintaining this product.

This manual has been compiled by Draper Tools describing the purpose for which the product has been designed, and contains all the necessary information to ensure its correct and safe use. By following all the general safety instructions contained in this manual, it will ensure both product and operator safety, together with longer life of the product itself.

All photographs and drawings in this manual are supplied by Draper Tools to help illustrate the operation of the product.

Whilst every effort has been made to ensure the accuracy of information contained in this manual, the Draper Tools policy of continuous improvement determines the right to make modifications without prior warning.

# 1. TITLE PAGE

---

## 1.1 INTRODUCTION:

**USER MANUAL FOR: 20V LI-ION 10L WET & DRY VACUUM CLEANER**

**Stock No: 98501**

**Part No: D20WDV10**

## 1.2 REVISION HISTORY:

---

**Date first published: June 2020.**

---

---

---

As our user manuals are continually updated, users should make sure that they use the very latest version.

**Downloads are available from:** <http://drapertools.com/manuals>

Draper Tools Limited  
Hursley Road  
Chandler's Ford  
Eastleigh  
Hampshire  
SO53 1YF  
UK

**Website:** [drapertools.com](http://drapertools.com)

**Product help line:** +44 (0) 23 8049 4344

**General Fax:** +44 (0) 23 8026 0784

## 1.3 UNDERSTANDING THIS MANUAL'S SAFETY CONTENT:

**WARNING!** – Information that draws attention to the risk of injury or death.

**CAUTION!** – Information that draws attention to the risk of damage to the product or surroundings.

## 1.4 COPYRIGHT © NOTICE:

Copyright © Draper Tools Limited.

Permission is granted to reproduce this publication for personal and educational use only. Commercial copying, redistribution, hiring or lending is prohibited.

No part of this publication may be stored in a retrieval system or transmitted in any other form or means without written permission from Draper Tools Limited.

In all cases this copyright notice must remain intact.

# 2. CONTENTS

---

## 2.1 CONTENTS

<b>1. TITLE PAGE</b>	
1.1 INTRODUCTION .....	2
1.2 REVISION HISTORY .....	2
1.3 UNDERSTANDING THIS MANUAL'S SAFETY CONTENT .....	2
1.4 COPYRIGHT® NOTICE .....	2
<b>2. CONTENTS</b>	
2.1 CONTENTS .....	3
<b>3. WARRANTY</b>	
3.1 WARRANTY .....	4
<b>4. INTRODUCTION</b>	
4.1 SCOPE .....	5
4.2 SPECIFICATION .....	5
4.3 HANDLING AND STORAGE .....	5
<b>5. HEALTH AND SAFETY INFORMATION</b>	
5.1 GENERAL SAFETY INSTRUCTIONS FOR POWER TOOL USE .....	6
5.2 RESIDUAL RISK .....	7
5.3 SAFETY INSTRUCTIONS FOR MAINS POWERED CHARGERS/BATTERY PACKS .....	7
5.4 CONNECTION TO THE POWER SUPPLY (CHARGER) .....	9
<b>6. TECHNICAL DESCRIPTION</b>	
6.1 IDENTIFICATION .....	10
<b>7. UNPACKING AND CHECKING</b>	
7.1 PACKAGING .....	11
7.2 D20 MULTI-TOOL INTERCHANGEABLE BATTERY SYSTEM .....	11
7.3 WHAT'S IN THE BOX .....	11
<b>8. PREPARING THE VACUUM CLEANER</b>	
8.1 ASSEMBLY .....	12
8.2 HOSE ASSEMBLY .....	12
8.3 WIDE HEAD ATTACHMENT .....	12
8.4 BATTERY PACK CHARGING .....	13
8.5 BATTERY PACK PROTECTION FEATURES .....	14
8.6 BATTERY PACK CHARGE STATUS .....	14
8.7 BATTERY LIFE EFFICIENCY AND CHARGING ADVICE .....	14
<b>9. OPERATING THE VACUUM CLEANER</b>	
9.1 VACUUM CLEANER OPERATION .....	15
<b>10. MAINTENANCE</b>	
10.1 CLEANING AND MAINTENANCE .....	16
10.2 REMOVING AND CLEANING THE FILTER .....	16
10.3 CARE AND STORAGE .....	17
10.4 BATTERY REMOVAL AND DISPOSAL .....	17
<b>11. TROUBLESHOOTING</b>	
11.1 TROUBLESHOOTING GUIDE .....	18
<b>12. EXPLANATION OF SYMBOLS/PICTOGRAMS</b>	
12.1 EXPLANATION OF SYMBOLS .....	18
<b>13. DISPOSAL</b>	
13.1 DISPOSAL .....	19
<b>DECLARATION OF CONFORMITY .....</b>	<b>ENCLOSED</b>

## 3. WARRANTY

---

### 3.1 WARRANTY

Draper tools have been carefully tested and inspected before shipment and are guaranteed to be free from defective materials and workmanship.

Should the tool develop a fault, please return the complete tool to your nearest distributor or contact

**Draper Tools Limited, Chandler's Ford, Eastleigh, Hampshire, SO53 1YF. England.**

**Telephone Sales Desk: (023) 8049 4333 or Product Help Line (023) 8049 4344.**

A proof of purchase **must** be provided with the tool.

If upon inspection it is found that the fault occurring is due to defective materials or workmanship, repairs will be carried out free of charge. This warranty period covering parts is 24 months and labour is 12 months from the date of purchase except where tools are hired out when the warranty period is 90 days from the date of purchase. This warranty does not apply to any consumable parts, any type of battery or normal wear and tear, nor does it cover any damage caused by misuse, careless or unsafe handling, alterations, accidents, or repairs attempted or made by any personnel other than the authorised Draper warranty repair agent.

**Note:** If the tool is found not to be within the terms of warranty, repairs and carriage charges will be quoted and made accordingly.

This warranty applies in lieu of any other warranty expressed or implied and variations of its terms are not authorised.

Your Draper warranty is not effective unless you can produce upon request a dated receipt or invoice to verify your proof of purchase within the warranty period.

Please note that this warranty is an additional benefit and does not affect your statutory rights.

**Draper Tools Limited.**

## 4. INTRODUCTION

---

### 4.1 SCOPE

20V Wet and Dry 10L vacuum cleaner. Designed to pickup wet and dry materials.

This product is intended for use in the workshop and garage or DIY work around the home not for commercial use.

Any application other than that it was intended for, is considered misuse.

### 4.2 SPECIFICATION

Stock no. ....	98501
Part no. ....	D20WDV10
Tank volume .....	10L
Vacuum pressure .....	10kPa, 15kPa (2-step)
Weight (nett) .....	2.9kg

### 4.3 HANDLING AND STORAGE

- Care must be taken when handling this product.
  - Dropping this power tool could have an effect on its accuracy and could also result in personal injury. This product is not a toy and must be respected.
- Environmental conditions can have a detrimental effect on this product if neglected.
  - Exposure to damp air can gradually corrode components.
  - If the product is unprotected from dust and debris, components will become clogged.
  - If not cleaned and maintained correctly or regularly, the machine will not perform at its best.

## 5. HEALTH AND SAFETY INFORMATION

---

### 5.1 GENERAL SAFETY INSTRUCTIONS FOR POWER TOOL USE

When using any type of power tool there are steps that should be taken to make sure that you, as the user, remain safe.

Common sense and a respect for the tool will help reduce the risk of injury.

**Read the instruction manual fully.** Do not attempt any operation until you have read and understood this manual.

Most important you must know how to safely start and stop this machine, especially in an emergency.

**Keep the work area tidy and clean.** Attempting to clear clutter from around the machine during use will reduce your concentration. Mess on the floor creates a trip hazard. Any liquid spilt on the floor could result in you slipping.

**Find a suitable location.** If the machine is bench mounted the location should provide good natural light or artificial lighting as a replacement. Avoid damp and dust locations as it will have a negative effect on the machine's performance. If the machine is portable do not expose the tool to rain. In all cases do not operate power tools near any flammable materials.

**Keep bystanders away.** Children, onlookers and passers by must be restricted from entering the work area for their own protection. The barrier must extend a suitable distance from the tool user.

Unplug and house all power tools that are not in use. A power tool should never be left unattended while connected to the power supply. They must be housed in a suitable location, away locked up and from children. This includes battery chargers.

**Do not overload or misuse the tool.** All tools are designed for a purpose and are limited to what they are capable of doing. Do not attempt to use a power tool (or adapt it in any way) for an application it is not designed for. Select a tool appropriate for the size of the job. Overloading a tool will result in tool failure and user injury. This covers the use of accessories.

**Dress properly.** Loose clothing, long hair and jewellery are all dangerous because they can become entangled in moving machinery. This can also result in parts of body being pulled into the machine. Clothing should be close fitted, with any long hair tied back and jewellery and neck ties removed. Footwear must be fully enclosed and have a non-slip sole.

**Wear personal protective equipment (PPE).** Dust, noise, vibration and swarf can all be dangerous if not suitably protected against. If the work involving the power tool creates dust or fumes wear a dust mask. Vibration to the hand, caused by operating some tools for longer periods must be protected against. Wear vibration reducing gloves and allow long breaks between uses. Protect against dust and swarf by wearing approved safety goggles or a face shield. These are some of the more common hazards and preventions however, always find out what hazards are associated with the machine/work process and wear the most suitable protective equipment available.

**Do not breathe contaminated air.** If the work creates dust or fumes connect the machine (if possible) to an extraction system either locally or remotely. Working outdoors can also help if possible.

**Move the machine as instructed.** If the machine is hand held, do not carry it by the power supply cable. If the product is heavy, employ a second or third person to help move it safely or use a mechanical device. Always refer to the instructions for the correct method.

**Do not overreach.** Extending your body too far can result in a loss of balance and you falling. This could be from a height or onto a machine and will result in injury.

**Maintain your tools correctly.** A well maintained tool will do the job safely. Replace any damaged or missing parts immediately with original parts from the manufacturer. As applicable keep blades sharp moving parts clean, oiled or greased handles clean and emergency devices working.

## 5. HEALTH AND SAFETY INFORMATION

---

**Wait for the machine to stop.** Unless the machine is fitted with a safety brake, some parts may continue to move due to momentum. Wait for all parts to stop, then unplug it from the power supply before making any adjustments, carrying out maintenance operations or just finishing using the tool.

**Remove and check setting tools.** Some machinery requires the use of additional tools or keys to set, load or adjust the power tool. Before starting the power tool always check to make certain they have been removed and are safely away from the machine.

**Prevent unintentional starting.** Before plugging any machine in to the power supply, make sure the switch is in the OFF position. If the machine is portable, do not hold the machine near the switch and take care when putting the machine down, that nothing can operate the switch.

**Carefully select an extension lead.** Some machines are not suitable for use with extension leads. If the tool is designed for use outdoors, use an extension lead also suitable for that environment. When using an extended lead, select one capable of handling the current (amps) drawn by the machine in use. Fully extend the lead regardless of the distance between the power supply and the tool. Excess current (amps) and a coiled extension lead will both cause the cable to heat up and can result in fire.

**Concentrate and stay alert.** Distractions are likely to cause an accident. Never operate a power tool if you are under the influence of drugs (prescription or otherwise), including alcohol or if you are feeling tired. Being disorientated will result in an accident.

**Have this tool repaired by a qualified person.** This tool is designed to conform to the relevant international and local standards and as such should be maintained and repaired by someone qualified, using only original parts supplied by the manufacturer. This will ensure the tool remains safe to use.

### 5.2 RESIDUAL RISK

**Important:** Although the safety instructions and operating manuals for our tools contain extensive instructions of safe working with power tools, every power tool involves a certain residual risk which can not be completely excluded by safety mechanisms. Power tools must therefore always be operated with caution!

### 5.3 SAFETY INSTRUCTIONS FOR MAINS POWERED CHARGERS & BATTERY PACKS

- The charger is for indoor use only.
- Prior to plugging the charger in to the supply, check that the plug and the cable are in good repair. If either are damaged, have the defective item replaced immediately by a suitably qualified person. If the casing of the battery charger is damaged, it is good policy to have the charger checked over by a suitably qualified person.
- Only use a correctly rated mains outlet to provide power, do not plug into site generators, attach to engine generators or D.C. sources. Do not use a mains socket outlet that is not switched.
- Use the correct Draper charger in conjunction with it's corresponding battery pack (consult the Draper website for more information or to find your local stockist).
- Do not charge any other batteries with Draper chargers. Any other application is considered misuse.
- Do not attempt to charge battery packs that are too hot (over 30°C) or too cold (under 5°C), if these conditions apply set the battery pack aside to “normalise” before proceeding with the charging operation.

## 5. HEALTH AND SAFETY INFORMATION

---

- Set up the charger and cable in a safe place where it won't be knocked, tripped over, stepped on, etc. and where it is well ventilated. Make sure the ventilation slots in the charger case are not obstructed, plug the charger into the socket outlet.
- Inspect the battery pack for damage, if it is undamaged, plug it into the charger, ensuring the correct orientation. (Most chargers and batteries have 'keys' etc, to make sure the battery pack is not inserted incorrectly, if you are having to 'force' the battery pack into the charger, the chances are you have it the wrong way round, check and try again.)
- Switch the charger on and check that the correct indicators illuminate, allow the battery pack to charge (see the specific instructions for your charger). Once charging is complete, switch the charger off, remove the battery pack and store, repeat the procedure if you have more than one battery pack to charge.

**Caution:** When the battery charger has been continuously used, the battery charger will be hot. Once the charging has been completed, give 15 minutes rest until the next charge.

- After charging is complete, unplug the charger from the socket outlet by pulling on the plug. Do not pull on the cable. Store the charger in a dry secure place.
- If, when the charger was switched on, the correct indications did not occur, leave for two or three minutes to allow the charger to stabilise, if the correct indications occur, allow the charging cycle to proceed as normal. If no indication appears at all, switch off, remove the battery pack, unplug the charger, check that the charger contacts and the battery contacts are clean and repeat the process. If there is still no indication, switch off, remove the battery pack, unplug the charger and check the fuse. If the fuse is blown, replace and repeat the process. If the fuse blows again, or if the fuse was intact, attempt no further action. Refer the charger to a suitably qualified person for repair.

### Battery packs

- Before charging, read the instructions.
- For indoor use. Do not expose to rain.
- Only use Draper D20 battery packs with this product. Consult your Draper stockist for details.
- Do not charge any other manufacturer's battery packs using Draper chargers. Any other application is considered misuse.
- The battery must be removed from the appliance before it is recycled.
- The charger must be disconnected from the supply mains when removing the battery.
- The battery is to be disposed of in-line with local authority procedures.
- Do not use any other than the designated Draper batteries/chargers with this product.
- Do not crush, open or burn the battery. Exposure to potentially harmful materials may occur.
- In case of fire use CO<sub>2</sub> or dry chemical extinguisher.
- Do not expose to high temperatures >50°C. The battery may degrade at high temperatures.
- Charge battery in conditions between 5°C to 30°C with the specified charger designed for this battery.
- Do not use battery if it has been stored at 5°C or less. Allow it to "normalise" at room temperature before usage/charging.

### Warning!

#### • Leaking battery packs

- The electrolyte in battery packs is corrosive. Avoid contact with the skin.
- If contact is made, flush the area with running water, pat dry and seek medical attention and advice at the earliest opportunity.
- Inform medical personnel that the contaminant is a "high alkaline, corrosive liquid".
- If electrolyte comes into contact with the eyes, flush with copious amounts of water only. Seek medical attention immediately, relaying the information above.

---

## 5.4 CONNECTION TO THE POWER SUPPLY (CHARGER)

**Caution:** Risk of electric shock. Do not open.

This appliance is supplied with an approved plug and cable for your safety. The value of the fuse fitted is marked on the pin face of the plug. Should the fuse need replacing, ensure the substitute is of the correct rating, approved to BS1362 and ASTA or BSI Kite marked.

ASTA 

BSI 

The fuse cover is removable with a small plain slot screwdriver. Ensure the fuse cover is replaced before attempting to connect the plug to an electrical outlet. If the cover is missing, a replacement must be obtained or the plug replaced with a suitable type.

If a replacement plug is to be fitted this must be carried out by a qualified electrician.

The damaged or incomplete plug, when cut from the cable should be disabled to prevent connection to a live electrical outlet.

This appliance is Class II† and is designed for connection to a power supply matching that detailed on the rating label and compatible with the plug fitted.

If an extension lead is required, use an approved and compatible lead rated for this appliance. Follow all the instructions supplied with the extension lead.

†Double insulated : This product requires no earth connection as supplementary insulation is applied to the basic insulation to protect against electric shock in the event of failure of the basic insulation.

### IMPORTANT

**If using an extension lead, follow the instructions that came with your lead regarding maximum load while cable is wound. If in doubt, ensure that the entire cable is unwound. Using a coiled extension lead will generate heat which could melt the lead and cause a fire.**

## 6. TECHNICAL DESCRIPTION

### 6.1 IDENTIFICATION

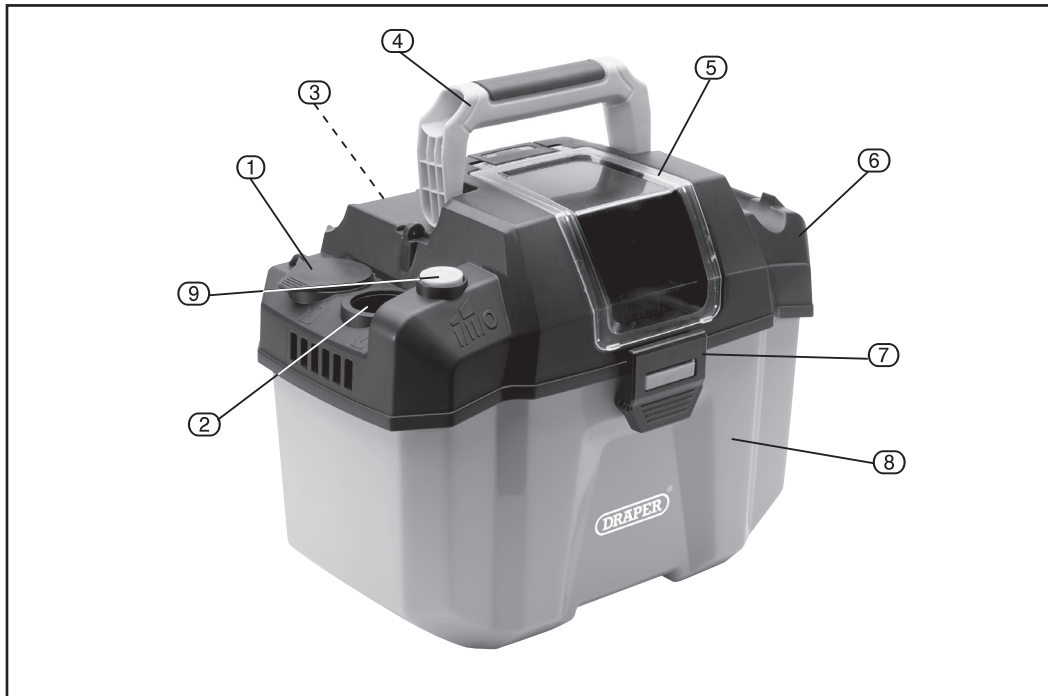

① Air blowing inlet

② Dust/water function inlet

③ Back Hook (not shown)

④ Handle

⑤ Battery pack cover

⑥ Top cover

⑦ Front Hook

⑧ Tank

⑨ On/off switch

## 7. UNPACKING AND CHECKING

### 7.1 PACKAGING

Carefully remove the product from the packaging and examine it for any sign of damage that may have happened during shipping. Lay the contents out and check them against the parts shown below. If any part is damaged or missing, please contact the Draper Help Line (the telephone number appears on the Title page) and do not attempt to use the product.

The packaging material should be retained at least during the warranty period, in case the machine needs to be returned for repair.

#### Warning!

- Some of the packaging materials used may be harmful to children. Do not leave any of these materials in the reach of children.
- If any of the packaging is to be thrown away, make sure they are disposed of correctly, according to local regulations.

### 7.2 D20 MULTI-TOOL INTERCHANGEABLE BATTERY SYSTEM

The D20 range of tools are a range of tools suitable for enthusiasts and tradespersons alike, featuring a wide array of machines all running from the same range of batteries.

Many different capacity batteries are available making sure you can balance tool weight with longevity and find a battery that meets your needs. To find out the latest range of accessories including batteries and chargers please consult the Draper website for more information or to find your local Draper stockist.



### 7.3 WHAT'S IN THE BOX

**Note:** For details of our full range of accessories and consumables, please visit [drapertools.com](http://drapertools.com)

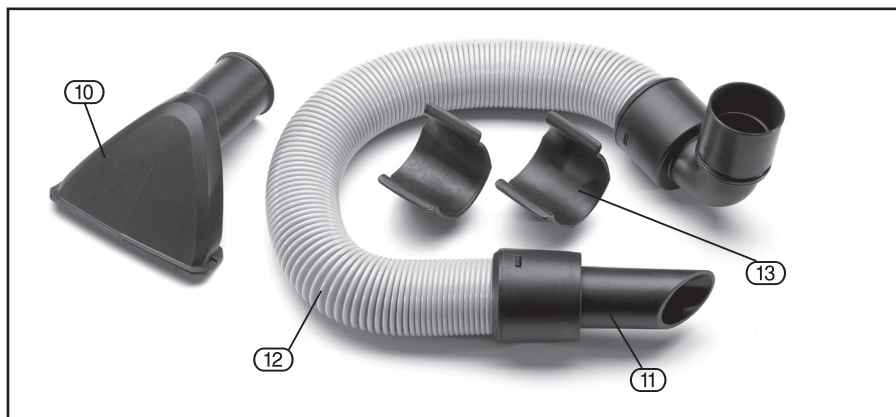

⑩ Wide head attachment

⑪ Hose handle

⑫ Hose

⑬ Hose clips x 2

## 8. PREPARING THE VACUUM CLEANER

### 8.1 ASSEMBLY – FIG. 1

**Note:** Release the front (7) and back (3) hooks, to open the top cover and take out the supplied accessories.

Fix the top cover back to the tank, and secure the front and back hooks. Secure the 2 x hose clips (13) as shown in Fig.1.



FIG. 1

### 8.2 HOSE ASSEMBLY – FIGS. 2–3

Insert the hose (12) into the hose inlet (1) located on the top cover.



FIG. 2

Secure the hose (12) into the 2 x hose clips.

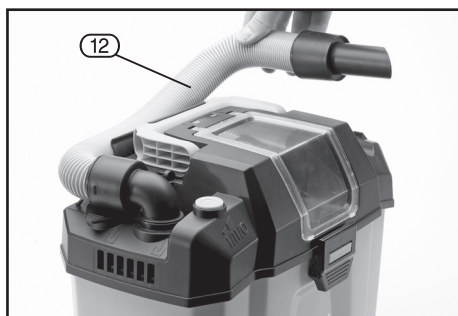

FIG. 3

### 8.3 WIDE HEAD ATTACHMENT – FIG. 4

Fix the wide head attachment (10) into the right position.

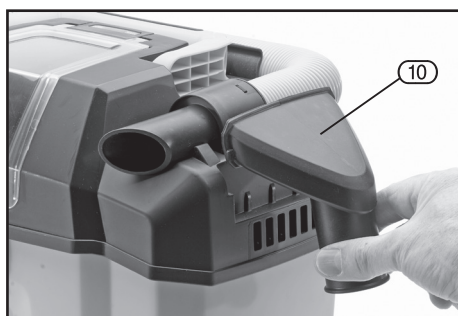

FIG. 4

## 8. PREPARING THE VACUUM CLEANER

### 8.4 BATTERY PACK CHARGING – FIGS. 5-6

This power product is supplied “bare” without battery pack or charger. Compatible batteries, chargers and accessories are available through Draper Tools stockists.

Important: Only Draper D20 designated battery packs and chargers can be used in conjunction with this product. Use of any other third party battery packs/chargers with this product is considered misuse and will invalidate the product’s warranty.

Once connected to the mains supply, recharging of the battery can be left generally unsupervised, requiring minimal attention. Complex circuit construction monitors the battery condition, adjusting the recharge current to suit. When the recharge cycle is complete, to maintain the full capacity, a low output current will continue as required.

Warning! Check the condition of the charger and battery prior to each charge. If there is any sign of damage then do not commence charging, seek advice from Draper Tools.

The battery pack is supplied un-charged and must be charged before initial use.

To charge the battery pack (14), it must first be removed from the tool.

To release the battery pack:

- Press the battery release button (14.1) and gently slide the battery pack off (Fig.5).
- Plug the battery charger (15) unit into a 230V/ AC 13amp three pin supply socket.
- The red LED (15.1) will illuminate to show the charger has power.
- Slide the battery into the charger (the battery is shaped to fit into the charger one way only).
- After a few seconds delay, the red LED (15.1) will flash to show that charging has begun, then illuminate solid red.
- Whilst the battery is charging, the green LED (15.2) will flash, (the red LED will go from flashing to constant red).
- When the battery is fully charged the green LED stops flashing and remains a constant green. The red LED will extinguish.

**Caution:** Do not pull the plug out of the power supply by pulling on the cord. Make sure to grasp the plug when removing from power supply to avoid damaging the cord.

To remove the battery from the battery charger:

- Supporting the battery charger with hand, pull out the battery from the battery charger.

**Caution:** If the battery charger has been in continuous use it will be hot. Once the charging has been completed, leave the charger 15 minutes to cool until next use.



FIG. 5

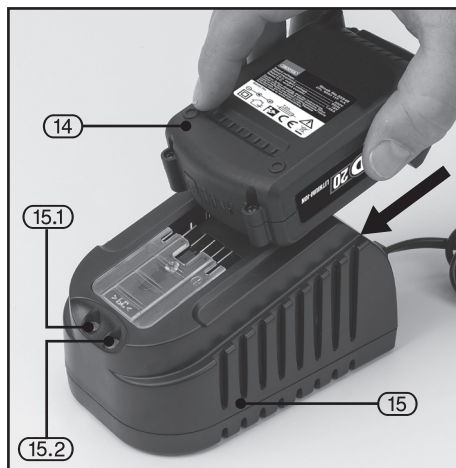

FIG. 6

## 8. PREPARING THE VACUUM CLEANER

If the battery is charged when it is warm due to battery use or exposure to sunlight, the battery will not be recharged. In such a case, let the battery cool before charging.

If the red indicator flickers rapidly at 0.2 second intervals, check or and remove any foreign objects in the charger's battery slot. If there are no foreign objects, it is probable that the battery or charger is malfunctioning. Allow battery/charger to normalise and try again. If a fault remains after trying this then contact Draper Tools.

### 8.5 BATTERY PACK PROTECTION FEATURES

**Overcharging protection:** This feature that ensures that the battery pack can never be overcharged. When the battery pack reaches full charge capacity, the transformer/charger will automatically shut off, protecting the internal components from being damaged.

**Over-discharging protection:** This feature will stop the battery pack from discharging beyond the recommended lowest safety voltage.

**Overheating protection:** The battery pack contains an internal thermistor cut-off sensor which shuts off the battery pack should it become too hot during operation. This can happen if the tool is overloaded or being used for extended periods. Up to 30 minutes cooling time may be required, depending on ambient temperature.

**Current protection:** Should the battery be overloaded and the maximum current draw be exceeded, the battery will shut off to protect the internal components. The battery pack will resume working once excessive current draw has returned to normal, safe level.

**Short circuit protection:** If, for any reason, the battery pack was to short circuit, the short circuit protection would immediately stop the battery pack from operating.

### 8.6 BATTERY PACK CHARGE STATUS – FIG. 7

To display the amount of charge left in the battery pack, press the charge level indicator button (14.2).

### 8.7 BATTERY LIFE EFFICIENCY AND CHARGING ADVICE

- Avoid recharging at high temperatures. A rechargeable battery will be hot immediately after use. If such a battery is recharged immediately after use, its internal chemical substance will deteriorate, and the battery life will be shortened. Leave the battery and recharge it after it has cooled for a while.
- The battery should only be used and/or charged when battery temperature is between 5°C and 30°C.
- The battery needs to be warmed-up or cooled down in order to prevent damage to the batteries internal components,

**Note:** If battery is too hot or too cold, allow it to 'normalise' before use or charging.

**Note:** Failure to warm up or cool down a battery could result in serious damage to the battery, charger and user.



Charge level indicator	Amount of charge remaining
	0 – 10%
	10 – 25%
	25 – 50%
	50 – 75%
	75 – 100%

FIG.7

## 9. OPERATING THE VACUUM CLEANER

### 9.1 VACUUM CLEANER OPERATION – FIGS. 8–9

To turn on the vacuum cleaner, push on/off switch (9) and the vacuum will start to work.

To use the vacuum under lower power, press the switch once. To operate the vacuum cleaner under a higher power, press the switch again.

To turn off the vacuum cleaner, press the switch again.



FIG. 8

The indicator light (Fig.9.) will be in green when the vacuum cleaner is working under low power. The light will then switch to red when it is working under high power.



FIG. 9

To clean water from the ground, use the wide head attachment (10) (FIG.10).

If the hose connector is inserted into inlet position (1) the air blowing function will be activated. If the hose connector is inserted into inlet position (2), the dust and water cleaning function is activated. (FIG 11).

**Note:** Ensure that the cover is open to start using blowing function, and put it back when finished.

**Important:** Please remove the battery from the vacuum for charging when not in use using D20 charging station (sold separately).



FIG. 10

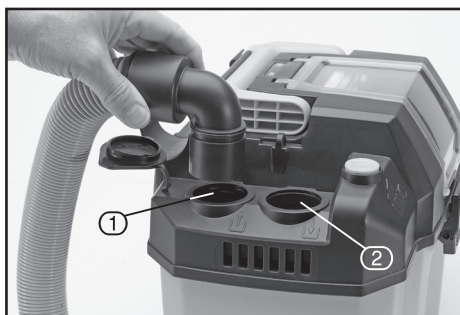

FIG. 11

# 10. MAINTENANCE

## 10.1 CLEANING AND MAINTENANCE – FIGS. 11-12

Release the front (7) and back (3) hooks (FIG.12) and remove the top cover (6) (FIG. 13).



FIG. 12

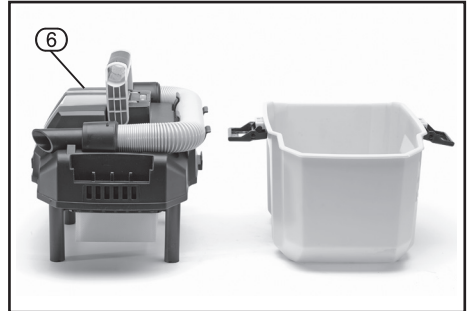

FIG. 13

Clean and wipe away any dust (FIG. 14).



FIG. 14

## 10.2 REMOVING AND CLEANING THE FILTER – FIGS. 15-16

Unscrew the 4 x screws using a screwdriver (not supplied) and remove the filter (14) (FIG. 15).

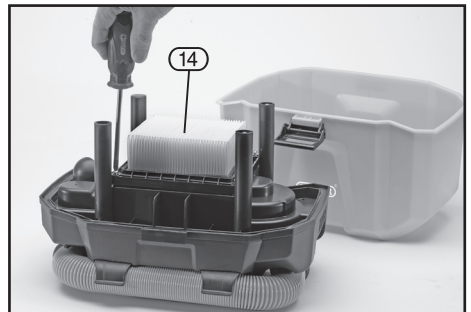

FIG. 15

## 10. MAINTENANCE

---

Wash off the filter (14) with clean water until all dirt has been removed (Fig. 16).

Once the filter is clean allow to dry in a cool and ventilated place.

**Note:** Replacement filters are available - see [drapertools.com](http://drapertools.com).

**Note:** Do not leave the filter to dry in direct sunlight.

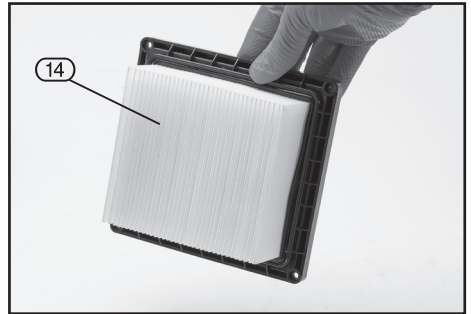

FIG. 16

### 10.3 CARE AND STORAGE

1. When not in use, turn off using the switch on top of the wet and dry vacuum, then disconnect and remove the 20V Li-ion battery.
2. Do not change filters, or carry out any cleaning or servicing, without first disconnecting the vacuum from the power supply.
4. Keep the external surfaces clean. Avoid impact damage & do not allow the vacuum to come into contact with abrasive or corrosive materials.
5. Do not use solvents, thinners or alcohol to clean the vacuum, as these chemicals will damage the finish. With the vacuum disconnected from the power supply, use a dry cloth to wipe over the casing.
6. When not in use the vacuum should be stored in a secure, dry place, out of the reach of children. DO NOT leave it exposed to the elements and avoid direct sunlight, direct heat, rain/moisture etc.
7. Only use parts and accessories recommended in this manual. The use of unauthorised accessories or attachments is not permitted and may result in personal injury or damage to the vacuum.
8. Do not attempt to repair or modify the vacuum. Do not attempt any electrical repair yourself. Consult a qualified electrician.

### 10.4 BATTERY REMOVAL AND DISPOSAL

**NOTE:** This product uses Lithium Ion rechargeable and recyclable batteries. When the batteries no longer hold a charge, they should be removed from the Vac and recycled. They must not be incinerated or composted.

To remove the battery pack for disposal:

1. First, before attempting to disassemble the product, turn it on and leave it on until the motor completely stops insuring a complete discharge of the batteries.
2. Using a phillips screwdriver, remove the seven screws securing the two housing halves.
3. Lift the housing cover away from the assembly.
4. Detach all lead connections from battery pack. Remove battery pack and dispose of as per recommended guidelines.

# 11. TROUBLESHOOTING

## 11.1 TROUBLESHOOTING GUIDE

**Note:** Repairs should only be carried out by a qualified person.

Problem	Possible Cause	Remedy
Motor does not start.	No battery inserted.	insert the battery.
	No power from the battery.	Battery needs to be charged.
	Vacuum is not power on.	Power on the vacuum.
Suction power is weak.	Vacuum unit is clogged.	Remove the blockage.
	Filter is clogged.	Clean or change the filter.
	Top cover is not fixed securely.	Ensure top cover is fixed by the front and back hooks.

# 12. EXPLANATION OF SYMBOLS/PICTOGRAMS

## 12.1 EXPLANATION OF SYMBOLS



Read the instruction manual.



Do not incinerate or throw onto fire.



Wear safety glasses.



WEEE –  
Waste Electrical & Electronic  
Equipment.



Wear ear defenders.



Do not dispose of Waste Electrical & Electronic Equipment in with domestic rubbish.



Class II construction  
(Double insulated).



For indoor use only.  
Do not expose to rain.

# 13. DISPOSAL

---

## 13.1 DISPOSAL

- At the end of the machine's working life, or when it can no longer be repaired, ensure that it is disposed of according to national regulations.
- Contact your local authority for details of collection schemes in your area.

In all circumstances:

- Do not dispose of power tools with domestic waste.
- Do not incinerate.
- Do not dispose of WEEE\* as unsorted municipal waste.



\* *Waste Electrical & Electronic Equipment.*

## CONTACTS

Draper Tools Limited, Hursley Road,  
Chandler's Ford, Eastleigh, Hampshire. SO53 1YF. U.K.

Help line: (023) 8049 4344

Sales desk: (023) 8049 4333

Internet: [drapertools.com](http://drapertools.com)

E-mail: [sales@drapertools.com](mailto:sales@drapertools.com)

General enquiries: (023) 8026 6355

**Service/Warranty Repair Agent:**

For aftersales servicing or warranty repairs, please contact the  
Draper Tools help line for details of an agent in your local area.

YOUR DRAPER STOCKIST

TADH0620

©Published by Draper Tools Limited.

No part of this publication may be reproduced, stored in a retrieval system or transmitted in any form or by any means, electronic, mechanical photocopying, recording or otherwise without prior permission in writing from Draper Tools Ltd.