

**Body-Solid**<sup>®</sup>  
Built for Life

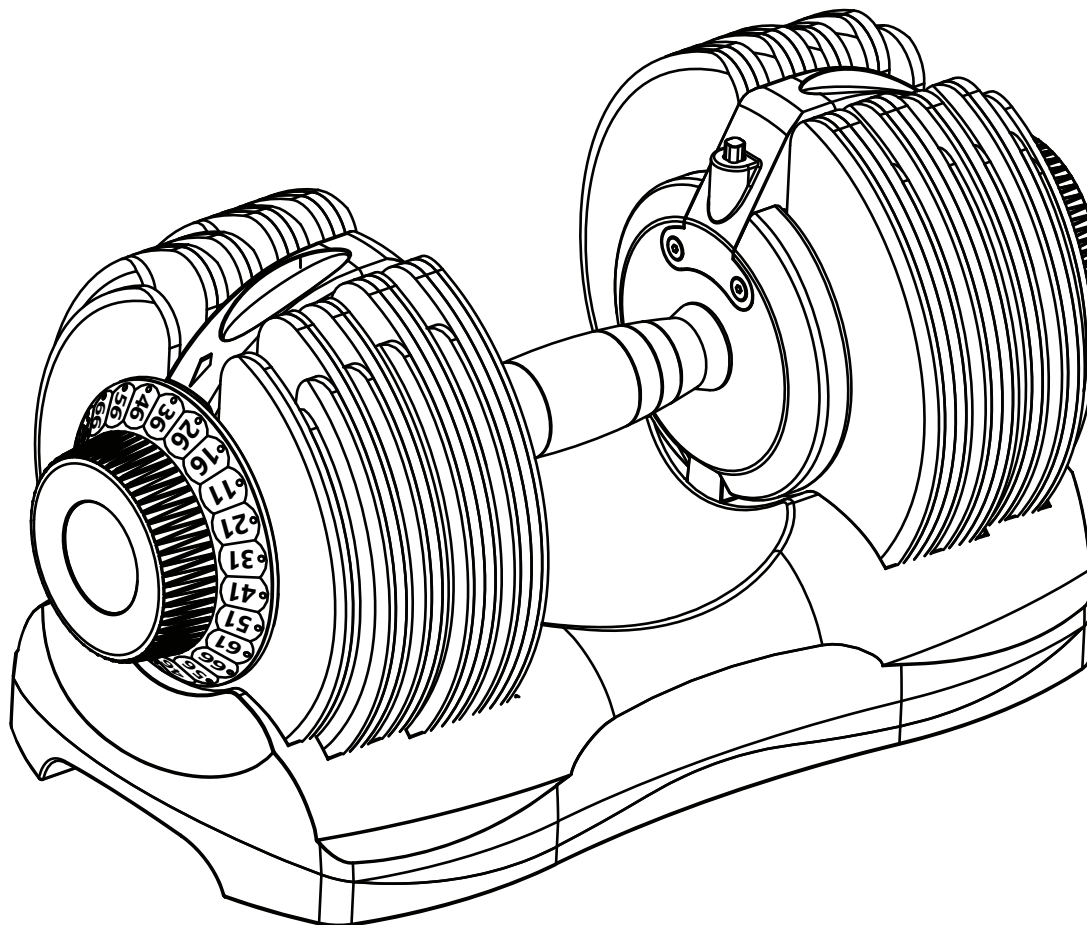

**66 LB Adjustable Dumbbell**  
**SDBX66**

Assembly Instructions

**OWNER'S & MANUAL**

V. SDBX66\_20231101

## **Warning, Safety & Maintenance**

- 1. WARNING: Do not drop the product, It will damage the product and void the warranty.**
- 2. The safety of this equipment can only be assured if it is examined regularly for damage and wear.**
- 3. Replace defective components immediately and keep the equipment out of until repair.**
- 4. Injuries may result from incorrect use of this equipment.**
- 5. Please consult a medical professional or personal trainer prior to commencing exercise to ensure it is safe for you to do so.**
- 6. If you have any health concerns or medical problems, please consult a doctor before using this equipment.**
- 7. Dress appropriately for exercise and wear comfortable clothing that allows full range of movement.**
- 8. This product is not a toy and is not suitable for children. please keep out of reach from children at all times.**
- 9. The minimum recommended age for the use of this equipment is 15 years old.**
- 10. Any use of this equipment in a commercial environment invalidates the warranty.**
- 11. Please do not press the red safety lock or turn the weight selector dials when the dumbbell or handle has been lifted from the dumbbell tray.**
- 12. If you have any questions about the product, please call our customer service department at 1-(800)-556-3113.**

**Keep the dumbbell tray in its upright position when unpacking the dumbbell and when using the dumbbell.**

## ➔ PRESS THE SAFETY LOCK

While the Dumbbell is resting on the Dumbbell Tray, press and hold the Red Safety Lock to engage the unlocked position.

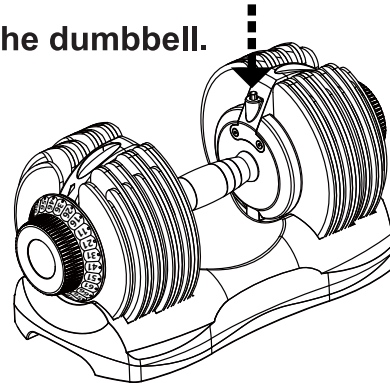

## ➔ SELECT THE DESIRED WEIGHT

Adjust the weight selector dial as the Safety Lock is held in the unlocked position. Rotate the weight selector dial to select the preferred weight for your personalized workout.

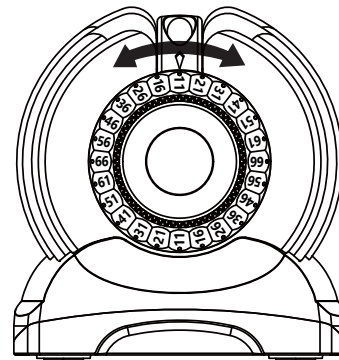

## ➔ RELEASE THE SAFETY LOCK

Release the Safety Lock returning it to the locked position. Make sure the Safety Lock is pop-up completely. Begin your workout!

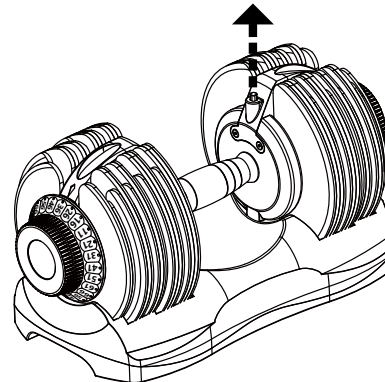

## ➔ PLACEMENT OF WEIGHT PLATES

The direction of the plate slot has to be placed in position as illustrated in the diagram to the right. The handle has to be adjusted to the lightest marking when there is no weight plate before it can be inserted into the plates.

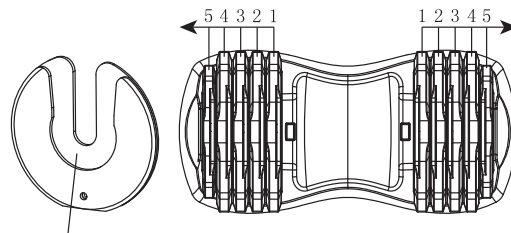

*Plate slot on one side only  
(the other side is flat)*



Please ensure the safety lock is completely released to the pop-up position prior to commencing exercise. Failure to release safety lock, may cause plates to become detached and risk injury. Do not drop dumbbells or bang dumbbells together during exercise.