

EN FRENCH DOOR BOTTOM
FREEZER/REFRIGERATOR

FR RÉFRIGÉRATEUR À PORTES
FRANÇAISES/CONGÉLATEUR EN BAS

ES REFRIGERADOR CON CONGELA-
DOR INFERIOR DE PUERTA DOBLE

USE AND CARE GUIDE

GUIDE D'UTILISATION ET D'ENTRETIEN

GUIA DE USO Y CUIDADO

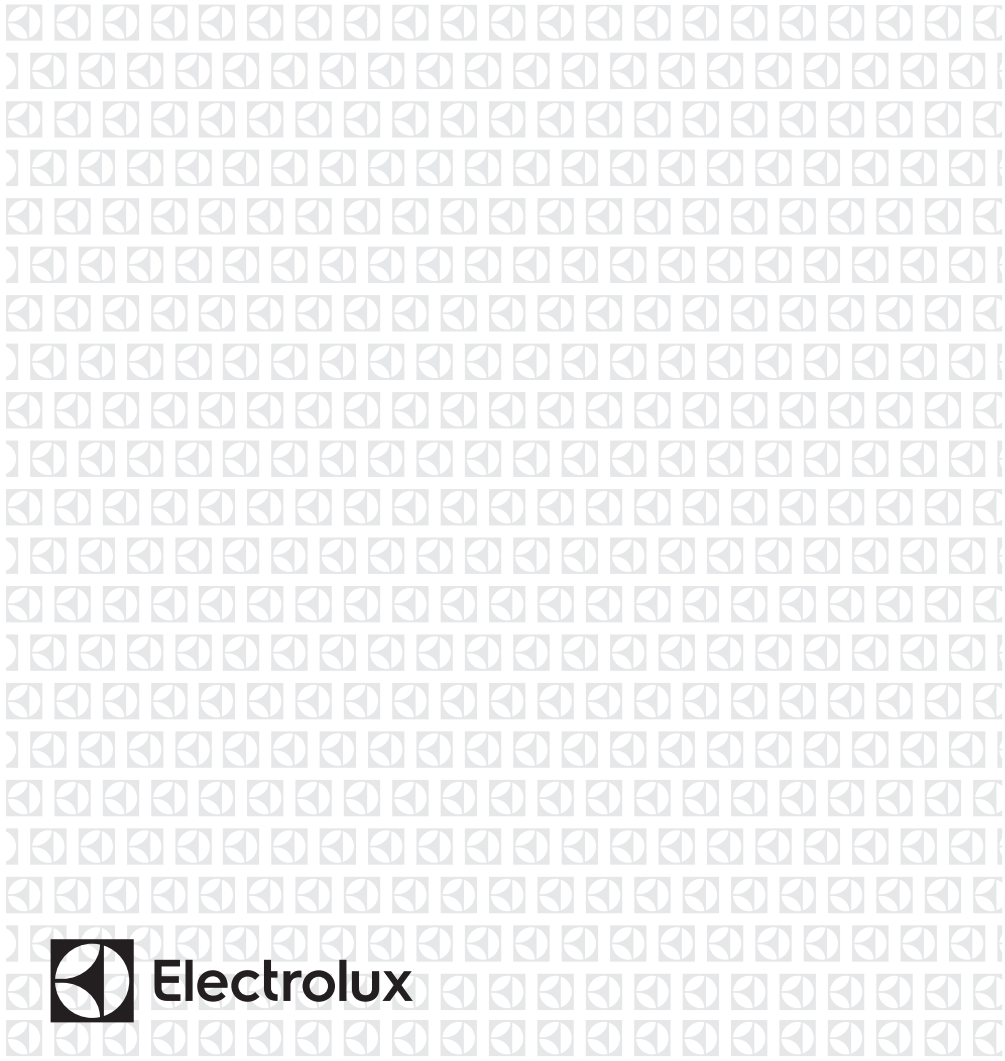

2 Finding Information

Please read and save this guide

Thank you for choosing Electrolux, our new premium brand in home appliances. This Use & Care Guide is part of our commitment to customer satisfaction and product quality throughout the service life of your new appliance.

Keep a record for quick reference

Purchase date

Electrolux model number

Electrolux serial number



NOTE

Registering your product with Electrolux enhances our ability to serve you. You can register online at www.electroluxappliances.com or by sending your Product Registration Card in the mail.

Questions?

For toll-free telephone support in the U.S. and Canada: 1-877-4ELECTROLUX (1-877-435-3287)

For online support and product information visit <http://www.electroluxappliances.com>

Table of contents

Finding Information	2
Safety	3
Feature Overview	5
Installation	6
Removing the Doors	10
Installing Door Handles	13
Connecting the Water Supply	14
Controls	16
Dispenser Model - Automatic Ice Maker/Water Dispenser	23
Automatic Ice Maker - Freezer	25
Storage Features	27
Storing Food and Saving Energy	31
Normal Operating Sounds	32
Changing the Water and Air Filters	33
Care and Cleaning	35
Solutions to Common Problems	37
Warranty	42

Installation Checklist

Doors

- Handles are secure and tight
- Door seals completely to cabinet on all sides

Leveling

- Refrigerator is level side-to-side and slightly elevated in front to assist with door and drawer closing (front should be higher than back)
- Toe grille is properly attached to refrigerator
- Cabinet is setting solid on all corners

Electrical Power

- House power turned on

- Refrigerator plugged in

Ice Maker

- House water supply connected to refrigerator
- No water leaks present at all connections - recheck in 24 hours
- Ice maker is turned ON
- Ice & water dispenser operates correctly

Final Checks

- Shipping material removed
- Fresh food and freezer temperatures set
- Crisper humidity controls set
- Registration card sent in

Important safety instructions

Safety Precautions

Do not attempt to install or operate your unit until you have read the safety precautions in this manual. Safety items throughout this manual are labeled with a Danger, Warning, or Caution based on the risk type.

Definitions

 This is the safety alert symbol. It is used to alert you to potential personal injury hazards. Obey all safety messages that follow this symbol to avoid possible injury or death.



DANGER

DANGER indicates an imminently hazardous situation which, if not avoided, will result in death or serious injury.



WARNING

WARNING indicates a potentially hazardous situation which, if not avoided, could result in death or serious injury.



CAUTION

CAUTION indicates a potentially hazardous situation which, if not avoided, may result in minor or moderate injury.



IMPORTANT

Indicates installation, operation, or maintenance information which is important but not hazard-related.

General Safety



WARNING

Please read all safety instructions before using your new refrigerator.

- Do not store or use gasoline or other flammable liquids near this or any other appliance. Read product labels for warnings regarding flammability and other hazards.

- Do not operate the refrigerator in the presence of explosive fumes.
- Avoid contact with any moving parts of the automatic ice maker.
- Remove all staples from the carton to avoid injury. Staples can also damage finishes if they come in contact with other appliances or furniture.

Child Safety

Packing Materials:

- Packing cartons covered with rugs, bedspreads, plastic sheets, or stretch wrap may become airtight chambers and can quickly cause suffocation.
- Destroy or recycle the product's carton, plastic bags, and any other exterior wrapping material immediately after the refrigerator is unpacked. Children should never play with these items.

Child Entrapment and Suffocation:

- These problems are not limited to the past. Whether junked, abandoned, or temporarily stored (even for a few hours), unattended refrigerators and freezers are dangerous. Please take the precautions listed below.

Proper Disposal of Refrigerators/Freezers

We strongly encourage responsible appliance recycling/disposal methods. Check with your utility company or visit www.energystar.gov/recycle for more information on recycling your old refrigerator.

Before you recycle or dispose of your old refrigerator/freezer:

- Remove the doors.
- Leave the shelves and baskets in place so children may not easily climb inside.
- Have refrigerant and compressor oil removed by a qualified service technician.

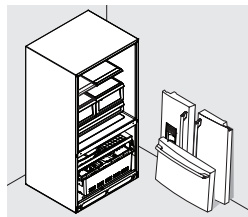

Electrical information



WARNING

You must follow these guidelines to ensure that your refrigerator's safety mechanisms are operating correctly.

- The refrigerator must be plugged into its own dedicated 115 Volt, 60 Hz, AC-only non-GFCI electric outlet. The power cord of the appliance is equipped with a three-prong grounding plug for your protection against electrical shock hazards. It must be plugged directly into a properly grounded three-prong receptacle. The receptacle must be installed in accordance with local codes and ordinances. Consult a qualified electrician. Do not use an extension cord or adapter plug.
- If the power cord is damaged, it should be replaced by the manufacturer, service technician, or a qualified person.
- Never unplug the refrigerator by pulling on the power cord. Always grip the plug firmly and pull straight out from the receptacle to prevent damaging the power cord.
- To avoid electrical shock, unplug the refrigerator before cleaning and before replacing a LED light.
- Performance may be affected if the voltage varies by 10% or more. Operating the refrigerator with insufficient power can damage the compressor. Such damage is not covered under your warranty.
- Do not plug the unit into an outlet controlled by a wall switch or pull cord to prevent the refrigerator from being turned off accidentally.

Grounding type wall receptacle

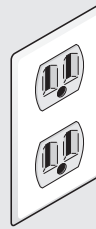

Do not, under any circumstances, cut, remove, or bypass the grounding prong.



Power cord with 3-prong grounded plug



IMPORTANT

To turn off power to your refrigerator, unplug the power cord from the wall outlet.

Understanding features and terms

Your Electrolux refrigerator is designed for optimal convenience and storage flexibility. The illustration below is provided to assist you with familiarizing yourself with product features and terminology.



NOTE

*Features may vary according to model. Dispenser model shown. Model is shown without freezer drawer cover.

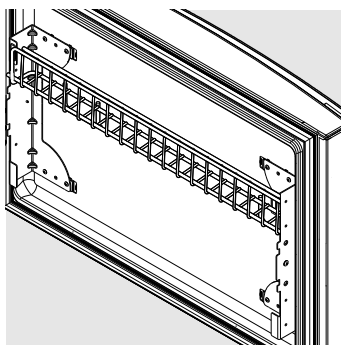
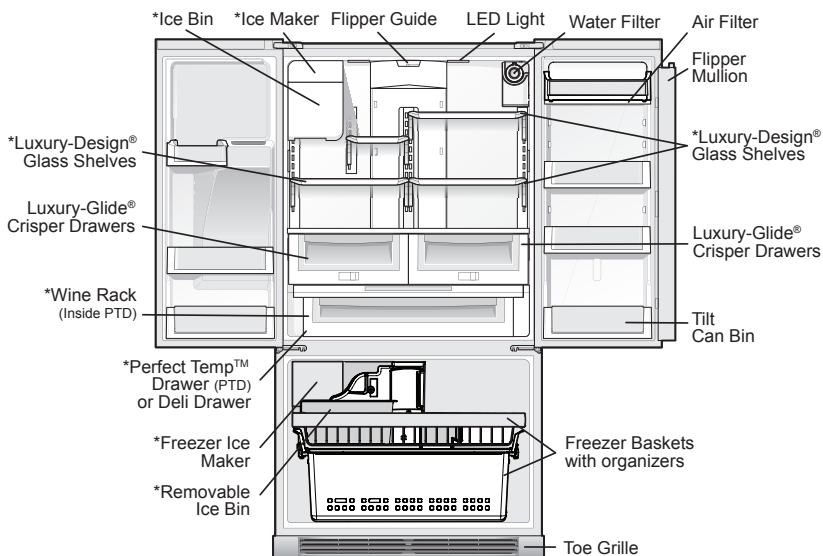

*Wire Shelf
(inside freezer drawer)



IMPORTANT

Features not included with your refrigerator can be purchased at www.electroluxappliances.com or by calling 1-877-435-3287.

Required Tools

You will need the following tools:

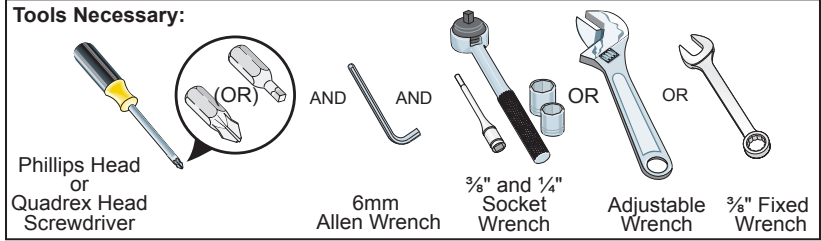

Components Provided:

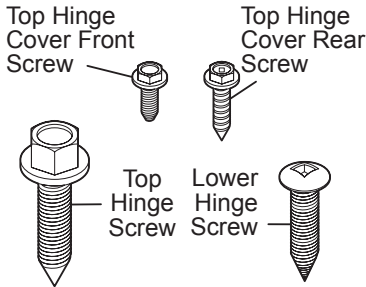

This Use & Care Guide provides general installation and operating instructions for your model. We recommend using a service or kitchen contracting professional to install your refrigerator. Use the refrigerator only as instructed in this Use & Care Guide. Before starting the refrigerator, follow these important first steps.

Location

- Choose a place that is near a grounded, non-GFCI, electrical outlet. Do Not use an extension cord or an adapter plug.
- If possible, place the refrigerator out of direct sunlight and away from the range, dishwasher, or other heat sources.
- The refrigerator must be installed on a floor that is level and strong enough to support a fully loaded refrigerator.
- Consider water supply availability for models equipped with an automatic ice maker.



CAUTION

DO NOT install the refrigerator where the temperature will drop below 55° F (13° C) or rise above 110° F (43° C). The compressor will not be able to maintain proper temperatures inside the refrigerator.

DO NOT block the toe grille on the lower front of your refrigerator. Sufficient air circulation is essential for the proper operation of your refrigerator.

Installation

- Allow the following clearances for ease of installation, proper air circulation, and plumbing and electrical connections:

Sides & Top	$\frac{3}{8}$ inch (9.5 mm)
Back	1 inch (25.4 mm)



NOTE

If your refrigerator is placed with the door hinge against a wall, you may have to allow additional space so the door can be opened wider.

Door opening



NOTE

The refrigerator doors are designed to shut by themselves within a 45 degree opening.

Your refrigerator should be positioned to allow easy access to a counter when removing food. For best use of refrigerator drawers and freezer baskets, the refrigerator should be in a position where both can be fully opened.



CAUTION

Do Not loosen or remove these 3 hex screws.

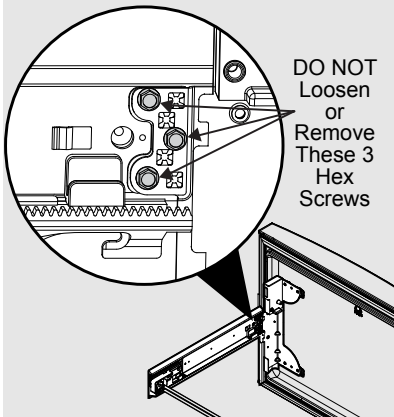

Cabinet Leveling & Refrigerator Door Alignment (if necessary)

Guidelines for final positioning of your refrigerator:

- All four corners of the cabinet must rest firmly on the floor.
- The front should be slightly elevated to ensure that doors close and seal properly.
- Doors should align with each other and be level.

Most of these conditions can be met by raising or lowering the adjustable front rollers.

To level the cabinet using the front rollers:

- 1 Slightly open freezer drawer if the toe grille is installed. Lift the toe grille and gently pull forward.
- 2 Make initial cabinet adjustments by using the front roller height adjusting screws. Use a 3/8 inch socket wrench to turn the adjustment screws (1 per side).

To raise: turn adjustment screw clockwise.

To lower: turn adjustment screw counterclockwise.

- 3 Ensure both doors are bind-free with their seals touching the cabinet on all four sides and that cabinet is stable.

- 4 After unit is leveled, lower anti-tip leg using a 3/8 inch socket wrench until it firmly contacts the floor.

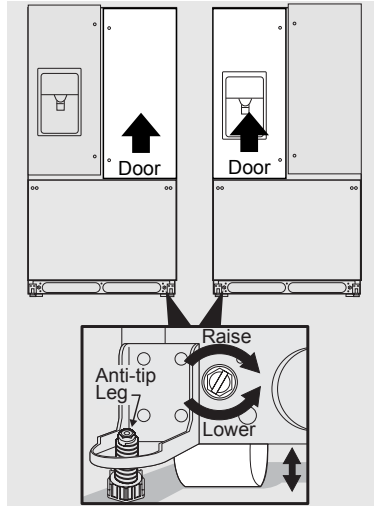

- 5 Install the toe grille by fitting into place.

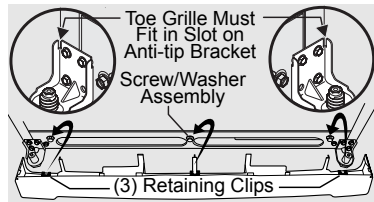

To make final door height adjustments:

1. Open freezer drawer to make lower hinge visible.
2. Insert 6mm Allen wrench into the shaft of the lower hinge.
3. Adjust the height by turning clockwise or counterclockwise. Turning clockwise will lower the door. Turning counterclockwise will raise the door. Default setting is to the lowest height when you receive your appliance.

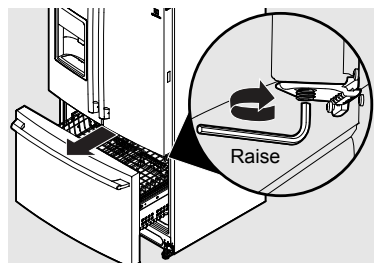

8 Installation

To adjust the flipper mullion:

- 1 Loosen the screw located on the flipper mullion hinge.

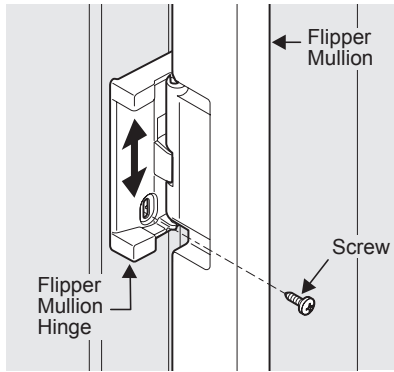

Adjusting Flipper Mullion Screw

- 2 Adjust flipper mullion height. For proper connection with the flipper mullion guide, there should be a separation about the thickness of a coin (0.060 inches, or 1.5 mm) between the guide and flipper mullion.

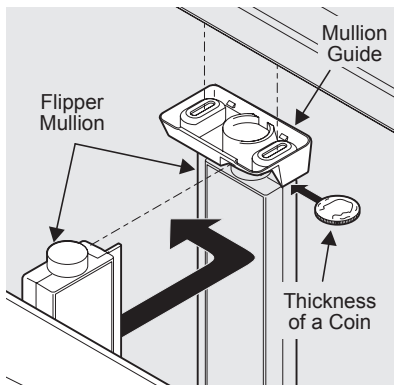

Adjusting Flipper Mullion Height

- 3 Re-tighten screw.

Installing Shelves (select models)

Your refrigerator was shipped with the shelf hanger and glass shelves in a shipping pack. Below are the instructions to install and remove the shelves in your desired locations.

- 1 Place top hooks of the hanger into the desired slot, and lower straight down until lower hooks rest on the ladder.
- 2 Relock shelf by pushing the slide mechanism away from you.

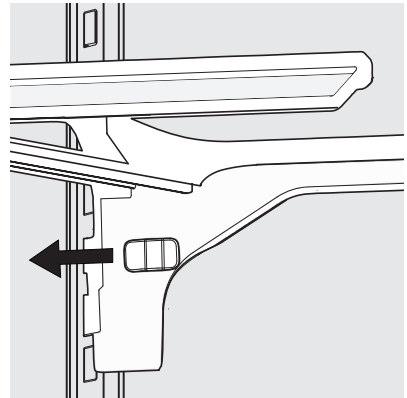

- 3 While holding shelf at a 45-degree angle with the gray handle facing you, push the shelf into the back of the hanger.

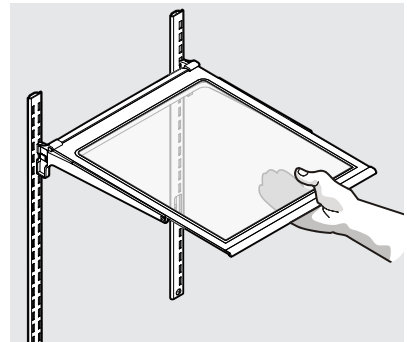

CAUTION

Shelves must be removed prior to moving the refrigerator.

- 4 Gently set the shelf onto the hanger once the back is secured by the hanger.

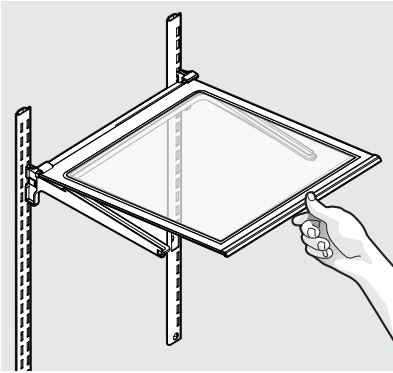

- 5 Remove shelf from its locked position by pulling the slide mechanism toward you.

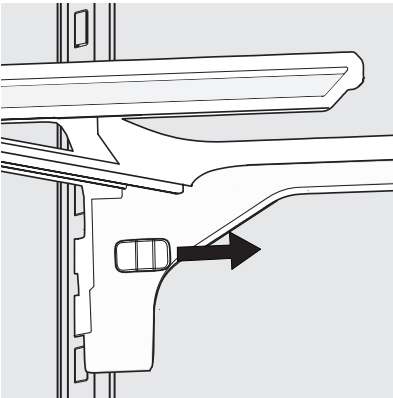

- 6 Lift the hanger directly upwards and pull toward you to remove it from the ladder.

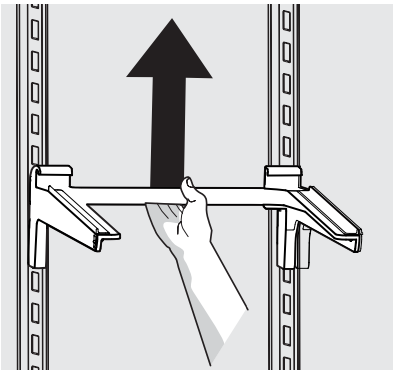

Reposition the Air Seal (select models)

- 1 Remove air seal by pushing seal straight back.
- 2 Position the air seal towards the outside edge of the shelf to avoid the air tower when shelf is pushed back into place.
- 3 Install seal by sliding the open channel end of the seal onto back edge of shelf until seal sits snug on back of shelf and flap sits at about a 10 degree angle from shelf surface.

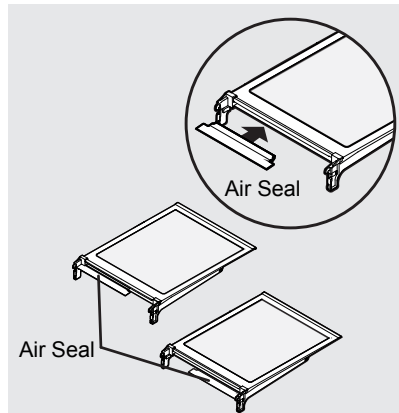

10 Installation

Shelf features (select models)



CAUTION

To avoid injury from breakage, handle tempered glass shelves carefully.



NOTE

Features may vary according to model.

Your refrigerator includes glass shelves that are designed to catch and hold accidental spills.

You can easily adjust shelf positions in the fresh food compartments to suit your needs. The shelves have mounting brackets that attach to slotted supports at the rear of each compartment.

To change the position of a shelf:

- 1 Before adjusting a shelf, remove all food.
- 2 Lift the front edge up and pull the shelf out.
- 3 Replace by inserting the mounting bracket hooks into the desired support slots.
- 4 Lower the shelf and lock into position.

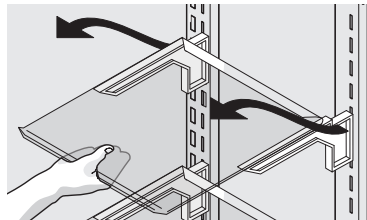
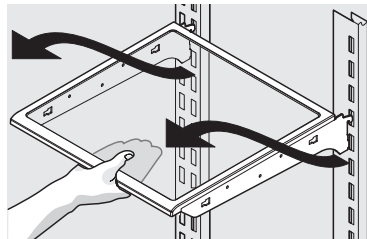
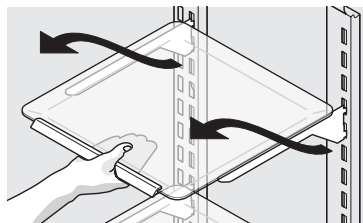

Full Luxury-Design™ Shelf (varies by model)

Reposition the Air Seal (select models)

For slide-out shelves:

- 1 Remove air seal by pushing down on the flap with a downward rotation.
- 2 Position the air seal towards the outside end of the shelf to avoid the air tower when shelf is pushed back into place.
- 3 Install seal by sliding lower tab of seal up into bottom rear slot of shelf with seal at a downward angle then pulling up on seal flap until seal sits snug on back of shelf and flap sits at about a 10 degree angle from shelf surface.

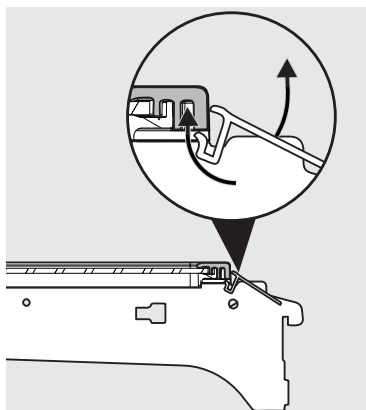

Getting through narrow spaces

If your refrigerator will not fit through an entrance area, you can remove the doors. Check first by measuring the entrance.

To prepare for removing the doors:

- 1 Make sure the electrical power cord is unplugged from the wall outlet.
- 2 Open the freezer drawer and remove the toe grille (see Installation section).
- 3 Remove any food from the door shelves and close the doors.

To remove the top hinge covers:

- 1 Remove the two screws from each cover over the top door hinges.
- 2 Lift inside edge of hinge cover and tilt back.

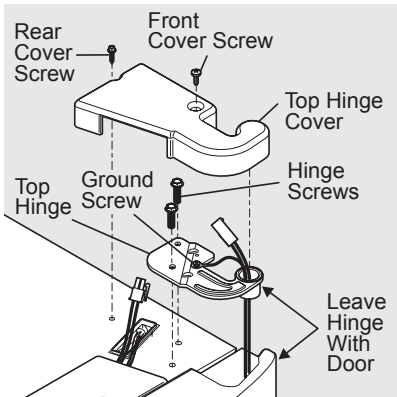
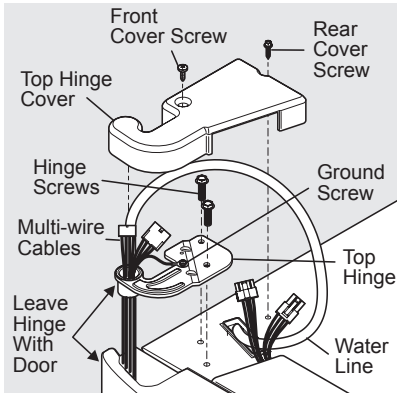

NOTE

DO NOT remove the ground screw from hinge.

To remove the refrigerator doors

- 1 Trace lightly around the door's top hinges with a pencil. This makes reinstallation easier.

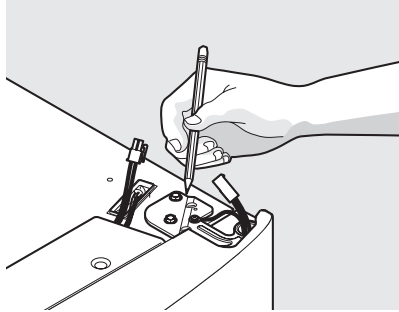

- 2 Disconnect the harness by grasping both sides of the connector firmly, depress the latch, and pull apart. Remove the two screws from the top hinge. Lift the door off of the bottom hinge and set it aside.

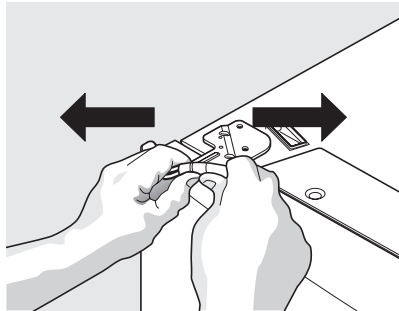

- 3 Detach the water tube from the connector located behind the refrigerator and pull the tube back out to the front of the unit. The connector releases when you press inward on the outer sleeve while pushing the tube toward the connector then while continuing to hold in the sleeve, pull the tube away.



NOTE

Use care while pulling the water tube from the unit to be sure that you do not kink the tube.

12 Removing the Doors

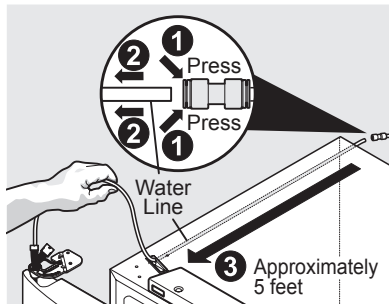

NOTE

You will be pulling approximately five feet of water tube from the back of the refrigerator.

- 4 Unscrew the three lower hinge screws and slide the hinge inwards.

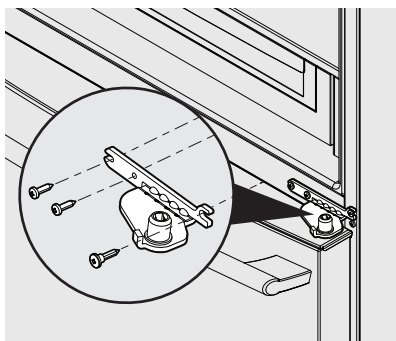

Lower Hinge Removal

CAUTION

Be sure doors are set aside in a secure position where they cannot fall and cause personal injury, or damage to the doors or handles.

To reinstall the refrigerator doors:

Reverse the above steps.

NOTE

Upon replacement, the tube needs to be fully inserted up to the marking line.

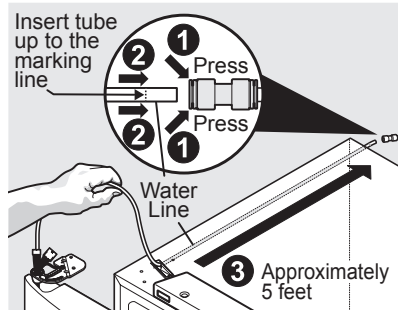

NOTE

When reinserting the water tube and replacing the top hinge cover, use care to be sure you do not kink the tube.

Once both doors are in place, ensure they are aligned with each other and level (Please see the **Installation** section for more details), and replace the top hinge cover.

Removing Freezer Drawer



CAUTION

Drawer is heavy. Use caution when lifting.

- 1 Remove 4 hex head drawer screws.
- 2 Lift up drawer to remove.

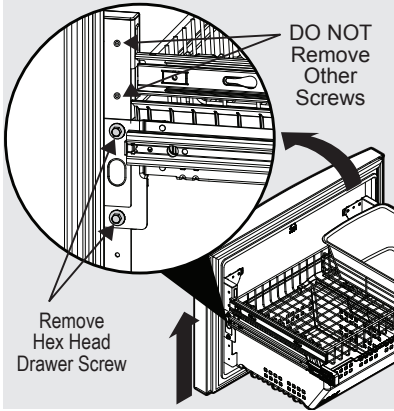

Replacing Freezer Drawer

- 1 Lower drawer back into place.
- 2 Replace 4 hex head drawer screws and tighten.

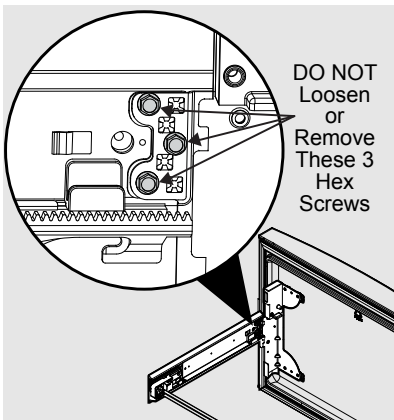

14 Installing Door Handles

Door Handle Mounting Instructions



CAUTION

Wear gloves and safety goggles. Use extreme CAUTION when installing these handles.

1. Remove handles from protective packaging.
2. Position fresh food handle end caps (A) over upper and lower pre-installed shoulder bolts (B) that are fastened into door, ensuring the holes for the set screws are facing towards the opposite door.
3. While holding handle firmly against door, fasten upper and lower Allen set screws (C) with supplied Allen wrench.



NOTE

An Allen wrench is supplied in the handle packaging. When using the Allen wrench to tighten the Allen set screws (C), it is imperative that force be applied to the longer arm of the Allen wrench to ensure that the set screws are completely tightened so that handles are flush with doors/drawer.

4. Repeat steps 2 and 3 to install opposite handle. Ensure the holes for the set screws are facing towards the first door.

Mounting Refrigerator Handles

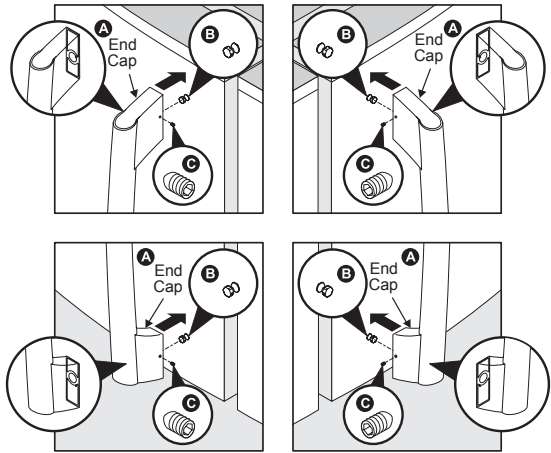

5. Position freezer handle end caps over left and right pre-installed shoulder bolts (B) that are fastened to the drawer, ensuring the holes for the set screws are facing down.
6. While holding handle firmly against drawer, fasten left and right Allen set screws (C) with supplied Allen wrench.

Mounting Freezer Handle

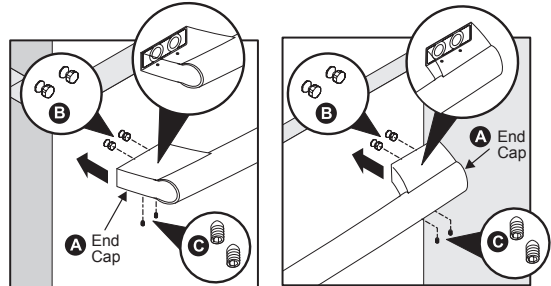



WARNING

To avoid electric shock, which can cause death or severe personal injury, disconnect the refrigerator from electrical power before connecting a water supply line to the refrigerator.



CAUTION

To Avoid Property Damage:

- Copper or Stainless Steel braided tubing is recommended for the water supply line. Water supply tubing made of ¼ inch plastic is not recommended to be used. Plastic tubing greatly increases the potential for water leaks, and the manufacturer will not be responsible for any damage if plastic tubing is used for the supply line.
- DO NOT install water supply tubing in areas where temperatures fall below freezing.
- Chemicals from a malfunctioning softener can damage the ice maker. If the ice maker is connected to soft water, ensure that the softener is maintained and working properly.



IMPORTANT

Ensure that your water supply line connections comply with all local plumbing codes.

Before installing the water supply line, you will need:

1. Basic Tools: adjustable wrench, flat-blade screwdriver, and Phillips™ screwdriver
2. Access to a household cold water line with water pressure between 30 and 100 psi.
3. A water supply line made of ¼ inch (6.4 mm) OD, copper or stainless steel tubing. To determine the length of tubing needed, measure the distance from the ice maker inlet valve at the back of the refrigerator to your cold water pipe. Then add approximately 7 feet (2.1 meters), so the refrigerator can be moved out for cleaning.
4. A shutoff valve to connect the water supply line to your household water system.
5. Do NOT reuse compression fitting or use thread seal tape.
6. A compression nut and ferrule (sleeve) for connecting a copper water supply line to the ice maker inlet valve.



NOTE

Check with your local building authority for recommendations on water lines and associated materials prior to installing your new refrigerator. Depending on your local/state building codes, Electrolux recommends for homes with existing valves its Smart Choice® water line kit 5305513409 with a 6 ft. (1.8 meters) Stainless Steel Water Line and for homes without an existing valve, Electrolux recommends its Smart Choice® water line kit 5305510264 with a 20 ft. (6 meters) Copper Water Line with self-tapping saddle valve). Please refer to www.electroluxappliances.com for more information.

16 Connecting the Water Supply

To connect water supply line to ice maker inlet valve:

1. Disconnect refrigerator from electric power source.
2. Place end of water supply line into sink or bucket. Turn ON water supply and flush supply line until water is clear. Turn OFF water supply at shutoff valve.
3. Remove plastic cap from water valve inlet and discard cap.
4. If you use copper tubing - Slide brass compression nut, then ferrule (sleeve) onto water supply line. Push water supply line into water valve inlet as far as it will go ($\frac{1}{4}$ inch / 6.4 mm). Slide ferrule (sleeve) into valve inlet and finger tighten compression nut onto valve. Tighten another half turn with a wrench; DO NOT over tighten. See Figure 1.

If you use braided flexible stainless steel tubing - The nut is already assembled on the tubing. Slide nut onto valve inlet and finger tighten nut onto valve. Tighten another half turn with a wrench; DO NOT over tighten. See Figure 2.

5. With steel clamp and screw, secure water supply line (copper tubing only) to rear panel of refrigerator as shown.
6. Coil excess water supply line (copper tubing only), about $2\frac{1}{2}$ turns, behind refrigerator as shown and arrange coils so they do not vibrate or wear against any other surface.
7. Turn ON water supply at shutoff valve and tighten any connections that leak.
8. Reconnect refrigerator to electrical power source.
9. To turn ice maker on, lower wire signal arm (freezer ice maker) or use the digital control setting to turn the ice maker's On/Off switch to the On position (fresh food ice maker).

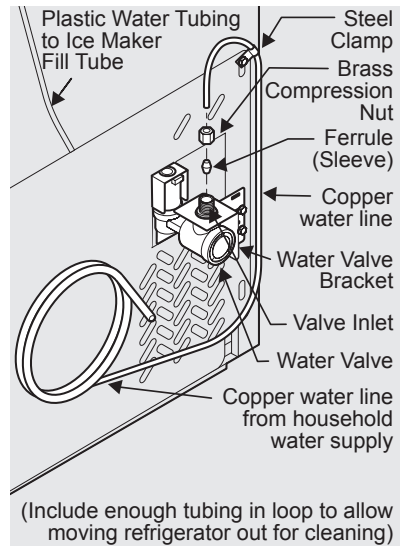

Figure 1

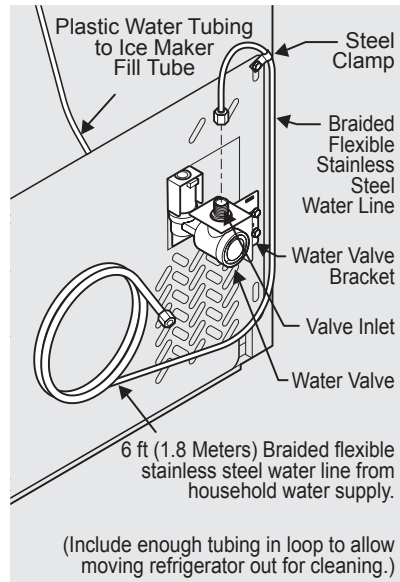
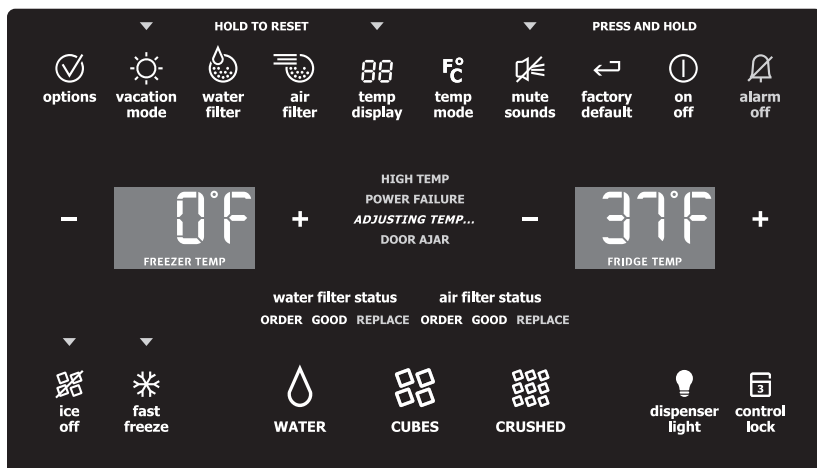
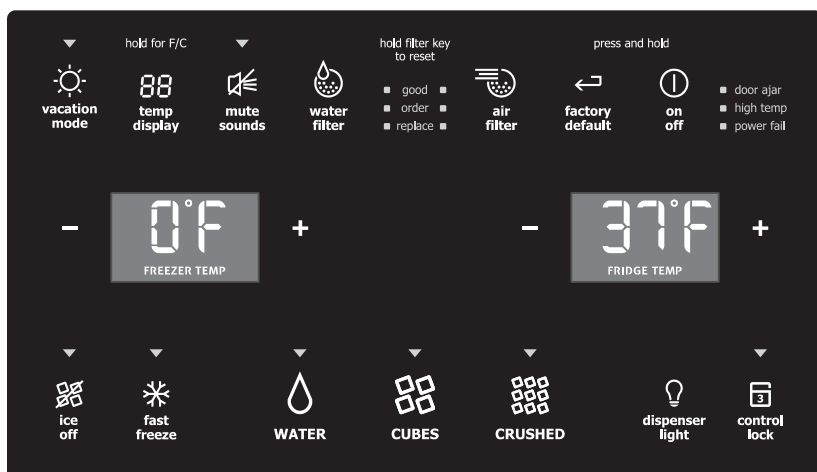

Figure 2

Wave-Touch™



IQ-Touch™



18 Controls - Dispenser Models

Wave-Touch™ (select models)

Your refrigerator is equipped with a Wave-Touch™ control panel display. It is only necessary to gently touch the glass. There are three levels of display.

1st Level: Sleep Mode

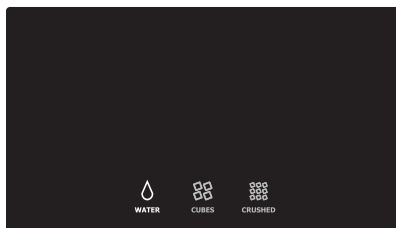

Sleep Mode displays only the water, cubes and crushed options. Touch an icon to activate the desired dispenser mode. The active dispenser mode is more brightly illuminated.

2nd Level: Awakened Display Mode

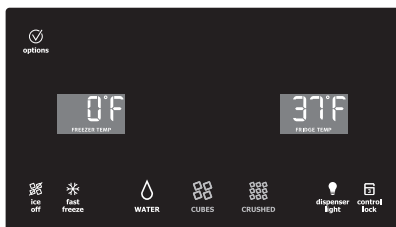

The control panel is awakened by touching anywhere on the glass where there is an indicator. Black space will not awaken the display. After 10 seconds of inactivity, the control panel will return to the Sleep mode.

The following dispenser options are illuminated:

ice off (Fresh Food Ice Maker) Press and hold for three seconds to turn the ice maker ON or OFF. The ice maker is OFF when the LED above the Ice Off icon is illuminated. If there is no indicator, then the ice maker is ON.

fast freeze Activates a faster rate for freezing food and increased freezer ice production.



NOTE

Refer to Automatic Ice Maker-Freezer section for freezer ice maker controls.

dispenser light On / Off

control lock Press and hold for three seconds to activate and deactivate. This restricts undesired changes to the refrigerator's settings and prevents use of the ice and water dispenser.

3rd Level: User Variable Options

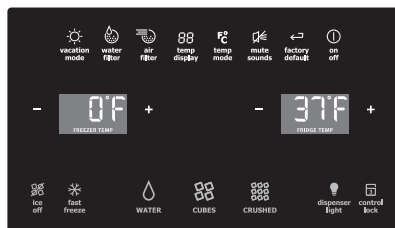

Touching the options icon displays the following options:

vacation mode Conserves energy by increasing the time between automatic defrost. This feature is automatically activated during long periods between door openings. Vacation mode is manually activated when the indicator is lit.

water filter Touch to display filter condition status. Press and hold for three seconds to reset after filter change.

air filter Touch to display filter status. Press and hold for three seconds to reset after filter change.

temp display When active, it allows the display of the freezer and fridge setting during Sleep Mode. The setting is displayed when the indicator is lit.

temp mode Touch to toggle display from Fahrenheit to Celsius.

mute sounds Tones emitted by each keypress can be turned off based on user preference. The sounds are muted when the indicator is lit. Warning signals will stay active.

factory default Resets all refrigerator settings such as temp, temp display, and alarm tones to their factory default settings.

on off Press and hold for three seconds to turn off the cooling system to clean the refrigerator. It also turns off the Fresh Food ice maker, all dispenser functions, and the Perfect Temp™ drawer (select models). The temperature display will read OFF.

▶ IMPORTANT

Pressing the system on/off icon does not turn off power to your refrigerator. You must unplug the power cord from the wall outlet.

Setting cooling temperatures

- 1 Touch the glass panel to illuminate the 2nd level of display.
- 2 Select the options icon. Plus (+) and minus (-) indicators will appear on either side of the displayed temperatures.
- 3 Press the + or - indicator to adjust the temperature to the desired temperature settings.
The temperature setting display will begin to blink with the first touch. After five seconds of inactivity, the display will beep to accept the new temperature. After 10 seconds, the display times out and returns to the basic display.

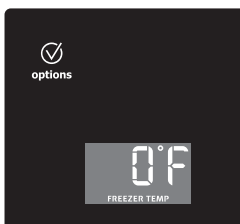

🗨️ NOTE

The recommended settings for a product installed in a kitchen is 37°F for the fresh food compartment and 0°F for the freezer.

▶ IMPORTANT

If your product has food freezing in the fresh food compartment, increase the temperature setting 1 or 2 degrees.

▶ IMPORTANT

If you place food within 1 inch in front of the air ports, there may be the chance of freezing food.

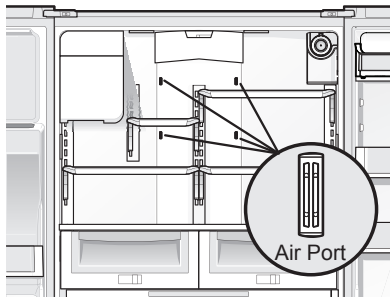

Alarms

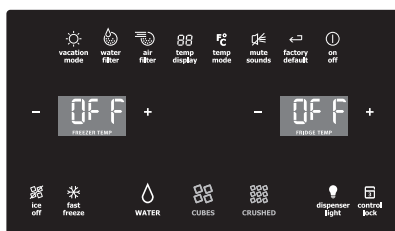

Door Ajar

If the door has been left open for an extended period of time, an alarm will sound and the door ajar indicator will display on the center of the display. The alarm is turned off by closing the door. The alarm off key will blink to prompt the reset of any pending alarms. Press this key to reset any system alarms.

High Temp

In the event of a high temperature condition, the temperature display will blink and display HI. After 20 minutes, the high temp alert will be displayed and the alarm off icon will illuminate until pressed, acknowledging the alarm, at which time the highest temperature reached will be displayed and the refrigerator will resume normal operation. All other modes are turned off until the alarm is acknowledged.

Power Fail

In the event of a power failure, the power fail alert will be displayed and the alarm off key will blink until the alarm off icon is pressed, acknowledging the alarm. Other modes may be turned off until the alarm is acknowledged. When the power fail alert is turned off, the refrigerator will resume normal operation. The high temp alarm may also be illuminated until a safe operating range temperature has been reached.

20 Controls - Dispenser Models

Wave-Touch™ / IQ-Touch™ Sabbath Mode

The Sabbath Mode is a feature that disables portions of the refrigerator and its controls for both Wave-Touch™ and IQ-Touch™, in accordance with observance of the weekly Sabbath and religious holidays within the Orthodox Jewish community.

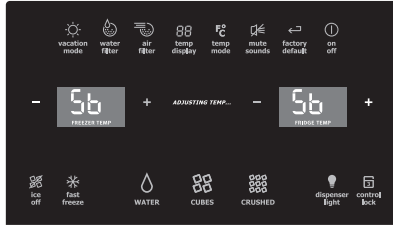

NOTE

While in Sabbath Mode, the Wave-Touch™ model will only illuminate the -/+ keys used to turn the Sabbath Mode Off.

Sabbath Mode is turned on and off by simultaneously pressing and holding the freezer temperature - and the refrigerator temperature + indicators for five seconds for both the Wave-Touch™ and IQ-Touch™ modes. The display shows Sb while in Sabbath mode.

In the Sabbath Mode, the High Temp alarm is active for health reasons. For example, if the door is left ajar the High Temp alarm is activated. The refrigerator will function normally once the door is closed, without any violation of the Sabbath/Holidays. The High Temp alarm is permitted when cabinet temperature is outside the safe zone for 20 minutes. The alarm silences itself after 10 minutes while the High Temp icon stays lit until the Sabbath mode is exited.

For further assistance, guidelines for proper usage and a complete list of



models with the Sabbath feature, please visit the web at <http://www.star-k.org>.

NOTE

While in Sabbath Mode, neither the lights, dispenser, nor the control panel will work until Sabbath Mode is deactivated.

Refrigerator stays in Sabbath Mode after power failure recovery. It must be deactivated with the buttons on the control panel.

NOTE

During Sabbath Mode, the freezer ice maker will continue to work and must be manually turned off to be compliant with the Sabbath observances.

Sabbath Mode and the Perfect Temp™ Drawer

The Perfect Temp™ Drawer should be turned off for the Sabbath/Holidays. Before putting the refrigerator into the Sabbath mode, turn the Perfect Temp™ Drawer off by pressing the drawer on/off button. The display will show OFF and the drawer will turn off. Then enter the Sabbath mode function on the main refrigerator display. (See Wave-Touch/IQ-Touch Sabbath Mode section.) When in Sabbath mode, the display will not illuminate and the drawer will remain off. The drawer can still be used as a non-temp controlled drawer in this mode. When the refrigerator is taken out of Sabbath mode, the Perfect Temp™ Drawer will have to be turned back on.

NOTE

If the Perfect Temp™ Drawer is not turned off prior to putting the unit into Sabbath Mode, it will continue to adjust itself to maintain the set point even if the display does not illuminate to show that it is still on.

IQ-Touch™ (select models)

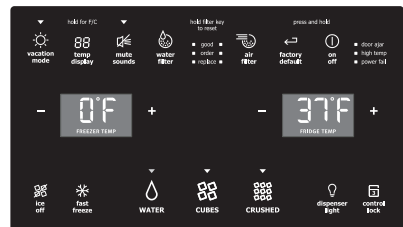

Your refrigerator is equipped with a glass touch control panel. It is only necessary to gently touch the glass. There are three dispenser modes:

- 1 Water
- 2 Ice Cubes
- 3 Crushed Ice

An indicator light will be illuminated above the active feature.

Touch the icon to activate the options below.

ice off (Fresh Food Ice Maker)	Press and hold for three seconds to turn the ice maker ON or OFF. The ice maker is OFF when the LED above the Ice Off icon is illuminated. If there is no indicator, then the ice maker is ON.
fast freeze	Activates a faster rate for freezing food and increased freezer ice production.



NOTE

Refer to Automatic Ice Maker-Freezer section for freezer ice maker controls.

dispenser light	On / Off
control lock	Press and hold for three seconds to activate and deactivate. This restricts undesired changes to the refrigerators settings and prevents use of the ice and water dispenser.
vacation mode	Conserves energy by increasing the time between automatic defrost. This feature is automatically activated during long periods between door openings. Vacation mode is manually activated when the indicator is lit.
water filter	Touch to display filter condition status. Press and hold for three seconds to reset after filter change.
air filter	Touch to display filter status. Press and hold for three seconds to reset after filter change.
temp display	Touch to toggle the freezer and fridge temp setting on and off. Touch and hold temp setting to toggle display from Fahrenheit to Celsius.
mute sounds	Tones emitted by each key press can be turned off based on user preference. The sounds are muted when the indicator is lit. Warning signals will stay active.
factory default	Resets all refrigerator settings such as temp, temp display, and ring tones to their factory default settings.
on off	Press and hold for three seconds to turn off the cooling system to clean the refrigerator. It also turns off the ice maker and all dispenser functions. The temperature display will read OFF.



IMPORTANT

Pressing the system on/off icon does not turn off power to your refrigerator. You must unplug the power cord from the wall outlet.

Setting cooling temperatures

- 1 Touch the control panel to illuminate plus (+) and minus (-) indicators on either side of the digital displays.
- 2 Press the + or - indicator to adjust the temperature to the desired setting.
The temperature setting display will begin to blink with the first touch. The display will time out after a minute and returns to the basic display.

Alarms

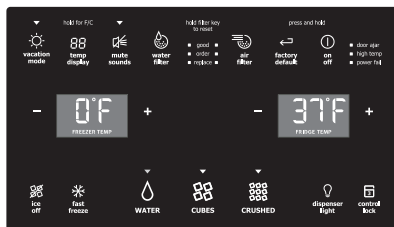

Door Ajar	If the door has been left open for an extended period of time, an alarm will sound and the door ajar indicator will display on the right side of the control panel. The alarm is turned off by closing the door. The mute sounds key will blink to prompt the reset of any pending alarms. Press this key to reset any system alarms.
High Temp	In the event of a high temperature condition, the temperature display will blink and display HI. After 20 minutes, the high temp alert will be displayed and the mute sounds indicator will illuminate until pressed, acknowledging the alarm, at which time the highest temperature reached will be displayed and the refrigerator will resume normal operation. All other modes are turned off until the alarm is acknowledged.
Power Fail	In the event of a power failure, the power fail alert will be displayed and the digital display will blink until the mute sounds icon is pressed, acknowledging the alarm. Other modes may be turned off until the alarm is acknowledged. The power fail alert is turned off and the refrigerator will resume normal operation. The high temp alarm may also be illuminated until a safe operating range temperature has been reached.

22 Controls - Non-Dispenser Models

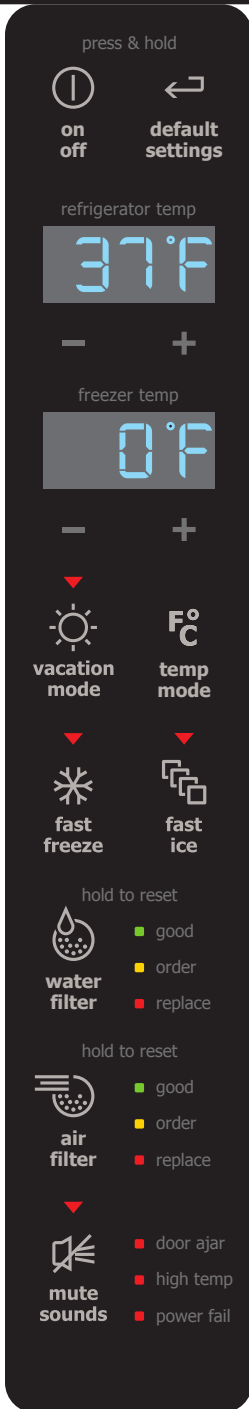

IQ-Touch™



IMPORTANT

Pressing the system on/off icon does not turn off power to your refrigerator. You must unplug the power cord from the wall outlet.

A red indicator light will be illuminated above most active features. Touch the icon to activate the options below.

fast freeze	Activates a faster rate for freezing food.
fast ice	Temporarily increases cooling for freezer to increase the production of ice
water filter	Press and hold for three seconds to reset after filter change.
air filter	Filter condition status is always displayed when door is open. Press and hold for three seconds to reset after filter change.
temp mode	Touch to toggle display from Fahrenheit to Celsius.
mute sounds	Tones emitted by each key press can be turned off based on user preference. The sounds are muted when the red indicator is lit. Warning signals will stay active.
default settings	Resets all refrigerator settings such as temp, temp display and tones to their factory default settings.
on off	Press and hold for three seconds to turn off the cooling system to clean the refrigerator. It also turns off the ice maker. The digital displays will read OFF.
vacation mode	Conserves energy by increasing the time between automatic defrost. This feature is automatically activated during long periods between door openings. Vacation mode is manually activated when the red indicator is lit.

Setting cooling temperatures

Press the + or – indicator to adjust the temperature to the desired setting.

The temperature setting will begin to blink with the first touch. The display will time out after 10 seconds and return to the basic display.



NOTE

The recommended settings for a product installed in a kitchen is 37°F for the fresh food compartment and 0°F for the freezer.

Alarms

Door Ajar If the door has been left open for an extended period of time, an alarm will sound and the door ajar indicator will display on the bottom display of the control panel. The alarm is turned off by closing the door. The mute sounds key will blink to prompt the reset of any active alarms. Press this key to reset any system alarms.

High Temp In the event of a high temperature condition, the temperature display will blink and display "HI". After 20 minutes, the alarm will sound and the high temp indicator will be red on the bottom of the control panel. The mute sounds icon will illuminate until pressed, acknowledging the alarm, at which time the highest temperature reached will be displayed and the refrigerator will resume normal operation. In case the high temp alarm is not acknowledged at the first alarm sound time out, when the door is first opened, the alarm sound will be repeated.

Power Fail In the event of a power failure, the power fail alert will be displayed and the temperature display will blink until the mute sounds icon is pressed, acknowledging the alarm. Other modes may be turned off until the alarm is acknowledged. The power fail alert is turned off and the refrigerator will resume normal operation. The high temp alarm may also be illuminated until a safe operating range temperature has been reached.

IQ-Touch™ "Sabbath Mode"

The Sabbath Mode is a feature that disables portions of the refrigerator and its controls for **IQ-Touch™**, in accordance with observance of the weekly Sabbath and religious holidays within the Orthodox Jewish community.

Sabbath Mode is turned ON and OFF by simultaneously pressing and holding the freezer temp "–" and the refrigerator temp "+." indicators for five seconds. The display shows "Sb" while in Sabbath mode.

In the Sabbath Mode, the High Temp alarm is active for health reasons. For

example, if the door is left ajar the High Temp alarm is activated. The refrigerator will function normally once the door is closed, without any violation of the Sabbath/Holidays. The High Temp alarm is permitted when cabinet temperature is outside the safe zone for 20 minutes. The alarm silences itself after 10 minutes while the High Temp icon stays lit until the Sabbath mode is exited.

For further assistance, guidelines for



proper usage and a complete list of models with the Sabbath feature, please visit the web at <http://www.star-k.org>.



NOTE

While in Sabbath Mode, neither the lights nor the control panel will work until Sabbath Mode is deactivated.

Refrigerator stays in Sabbath Mode after power failure recovery. It must be deactivated with the buttons on the control panel.



NOTE

During Sabbath Mode, the freezer ice maker will continue to work and must be manually turned off to be compliant with the Sabbath observances.

Sabbath Mode and the Perfect Temp™ Drawer

The **Perfect Temp™** Drawer should be turned off for the Sabbath/Holidays. Before putting the refrigerator into the Sabbath mode, turn the **Perfect Temp™** Drawer off by pressing the drawer on/off button. The display will show "OFF" and the drawer will turn off. Then enter the Sabbath mode function on the main refrigerator display. See the **IQ-Touch** "Sabbath Mode" section. When in Sabbath mode, the display will not illuminate and the drawer will remain off. The drawer can still be used as a non-temp controlled drawer in this mode. When the refrigerator is taken out of Sabbath mode, the **Perfect Temp™** Drawer will have to be turned back on.



NOTE

If the **Perfect Temp™** Drawer is not turned off prior to putting the unit into Sabbath Mode, it will continue to adjust itself to maintain the set point even if the display does not illuminate to show that it is still on.

Dispenser Model Automatic Ice Maker/Water Dispenser

Priming the water supply system



CAUTION

For proper dispenser operation, recommended water supply pressure should fall between 30 psi and 100 psi. Excessive pressure may cause water filter to malfunction.

- 1 Begin filling the filter by pressing and holding a drinking glass against the water dispenser paddle.
- 2 Keep the glass in this position until water comes out of the dispenser. It may take about 1½ minutes.
- 3 Continue dispensing water for about three minutes to flush the system and plumbing connections of any impurities (stopping to empty the glass as necessary).



NOTE

The water dispenser has a built-in device that shuts off the water flow after two minutes of continuous use. To reset this shutoff device, simply release the dispenser paddle.

Ice maker operation & care

After the refrigerator is installed properly and has cooled for several hours, the ice maker can start producing ice within 24 hours. The ice maker will fill the ice bin from the rear. You must dispense some ice to force the ice forward in the bin. Full bin should be expected after 48 to 60 hours with no ice usage. Ice rate is 2.3 lbs. per day. For extra capacity you can add an ice maker kit for the freezer.



IMPORTANT

Your ice maker is turned on at the factory so it can work as soon as you install your refrigerator. If you cannot connect a water supply, set the ice maker's On/Off icon to Off and turn off the water supply valve; otherwise, the ice maker's fill valve may make a loud chattering noise when it attempts to operate without water.

Turning the fresh food ice maker on and off

Ice production is controlled by the ice maker's On/Off icon on the control panel. Press and hold the Ice Off icon for three seconds to turn the ice maker ON or OFF. If there is no indicator, then the ice maker is ON.

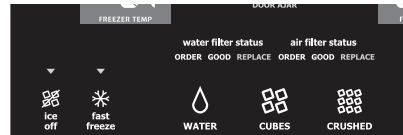

IMPORTANT

Turning off the ice maker stops ice production only.



NOTE

The ice maker also has a built-in signal bale arm that automatically stops ice production when the ice bin is full. This signal arm should not be used to manually stop the ice maker.

Using the ice maker after installation

Before making ice for the first time, be sure to prime the water supply system. Air in new plumbing lines can result in two or three empty ice maker cycles. Furthermore, if the system is not flushed, the first ice cubes may be discolored or have an odd flavor.



IMPORTANT

On occasion, unusually small ice cubes may be noticed in the bucket or in dispensed ice. This could occur in normal operation of the ice maker. If you start seeing these more frequently, it may be an indication of low water pressure or the water filter needs to be replaced. As the water filter nears the end of its useful life and becomes clogged with particles, less water is delivered to the ice maker during each cycle. Remember, if it's been six months or longer since you last changed your water filter, replace the water filter with a new one. Poor quality household water may require the filter to be changed more frequently.

Ice maker/dispenser tips

- If your refrigerator is not connected to a water supply or the water supply is turned off, turn off the ice maker by holding the On/Off soft-touch icon for three seconds.
- The following sounds are normal when the ice maker is operating:
 - Motor running
 - Ice dropping into ice bin
 - Water valve opening or closing
 - Running water
- If you need a large quantity of ice at one time, it is best to get cubes directly from the ice bin.
- Ice cubes stored too long may develop an odd flavor. Empty the ice bin as explained below.
- When dispensing cubed ice, it is normal to have a small quantity of little pieces along with the whole cubes.



CAUTION

If the water supply to your refrigerator is softened, be sure the softener is properly maintained. Chemicals from a water softener can damage the ice maker.

Cleaning the ice maker

Clean the ice maker and ice bin at regular intervals, especially prior to vacation or moving.

- 1 Turn off the ice maker.
- 2 Remove the ice bin by pulling straight out.
- 3 Empty and carefully clean the ice bin with mild detergent. Do not use harsh or abrasive cleaners. Rinse with clear water.
- 4 Allow the ice bin to dry completely before replacing.
- 5 Replace the ice bin. Turn the ice maker on.

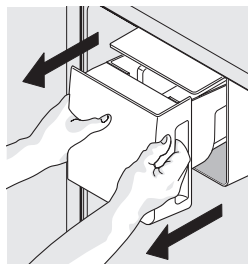

Removing Ice Bin

Remove and empty the ice bin if:

- An extended power failure (one hour or longer) causes ice cubes in the ice bin to melt and freeze together, jamming the dispenser mechanism.
- You do not use the ice dispenser frequently. Ice cubes will freeze together in the bin, jamming the dispenser mechanism.

Remove the ice bin and shake to loosen the cubes or clean as explained above.



CAUTION

NEVER use an ice pick or similar sharp instrument to break up the ice. This could damage the ice bin.

To loosen stuck ice, use warm water. Before replacing the ice bin, make sure it is completely dry.



IMPORTANT

When removing or replacing the ice bin, DO NOT rotate the auger in the ice bin. If the auger is accidentally rotated, you must realign the auger by turning it in 45 degree turns (see below) until the ice bin fits into place with the drive mechanism. If the auger is not properly aligned when replacing the ice bin, the refrigerator will not dispense ice. The fresh food door also may not close properly causing warm air to leak into the fresh food compartment.

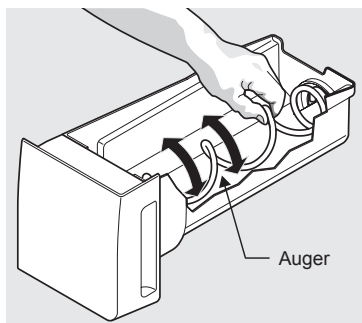

Adjusting Ice Bin Auger



NOTE

Dispenser models allow for an additional freezer ice maker to be installed. Call 1-877-435-3287 for more information.

26 Automatic Ice Maker - Freezer

Ice maker operation & care (select models)

After the refrigerator is installed properly, the ice maker can produce ice within 24 hours. It can completely fill an ice bin in about three days.

When using the ice maker for the first time and in order for the ice maker to work properly, it is necessary to clear air from water filter tubing. Once ice maker begins making ice, allow the bucket to fill completely, then discard the first TWO FULL buckets of ice. It will take at least two days to completely fill the bucket on regular ice making mode or 1½ days on fast ice mode.

The ice maker produces approximately four pounds of ice every 24 hours depending on usage conditions.



IMPORTANT

Your ice maker is turned on at the factory so it can work as soon as you install your refrigerator. If you cannot connect a water supply, lift the ice maker's wire signal arm to turn it off. Otherwise, the ice maker's fill valve may make a loud chattering noise when it attempts to operate without water.



NOTE

During the Sabbath Mode, the automatic ice maker will continue to work and must be manually turned off to be compliant with the Sabbath observance.

Turning the ice maker on and off

Ice production is controlled by lifting/lowering the ice maker's wire signal arm. To gain access to the ice maker, pull the freezer drawer out. Lift the wire signal arm to turn the ice maker OFF and lower the wire signal arm to turn it ON.

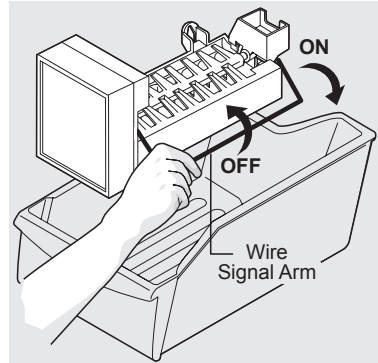

Ice maker tips

- If your refrigerator is not connected to a water supply or the water supply is turned off, turn off the ice maker by lifting wire signal arm.
- The following sounds are normal when the ice maker is operating:
 - Motor running
 - Ice dropping into ice bin
 - Water valve opening or closing
 - Running water
- Ice cubes stored too long may develop an odd flavor. Empty the ice bin as explained below.

Fast Ice Function

Your refrigerator is equipped with a "Smart" Fast Ice Function that will, if activated, allow an increase in freezer ice production. After time the refrigerator will return to normal ice production.



CAUTION

If the water supply to your refrigerator is softened, be sure the softener is properly maintained. Chemicals from a water softener can damage the ice maker.

Cleaning the ice maker

Clean the ice maker and ice bin at regular intervals, especially prior to vacation or moving.

- 1 Turn off the ice maker.
- 2 Remove the ice bin.
- 3 Empty and carefully clean the ice bin with mild detergent. Do not use harsh or abrasive cleaners. Rinse with clean water.
- 4 Allow the ice bin to dry completely before replacing in the freezer.
- 5 Replace the ice bin. Turn the ice maker on.

Remove and empty the ice bin if:

- An extended power failure (one hour or longer) causes ice cubes in the ice bin to melt and freeze together.

Remove the ice bin and shake to loosen the cubes or clean as explained above.



CAUTION

NEVER use an ice pick or similar sharp instrument to break up the ice. This could damage the ice bin.

To loosen stuck ice, use warm water. Before replacing the ice bin, make sure it is completely dry.

28 Storage Features

Drawers

Your refrigerator includes a variety of storage drawers.

Crispers

Crisper drawers are designed for storing fruits, vegetables, and other fresh produce. They feature a smooth-glide, ball-bearing system and soft-close functionality so as not to bruise your fruits and vegetables.

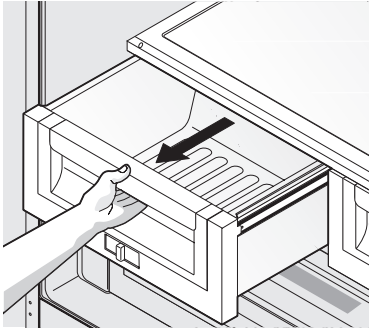

Opening Crisper Drawer

Crisper humidity control

Crisper drawers include a sliding control for adjusting the humidity inside the crisper. Leafy vegetables keep best when stored with the Humidity Control set on Higher Humidity. Fresh fruits keep best when stored with the Humidity Control set on Lower Humidity.

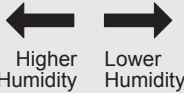

Adjusting Crisper Humidity
(varies by model)

To remove the Crisper Drawer for cleaning:

- 1 Pull the drawer out until it stops.
- 2 Lift the front slightly and remove the drawer.

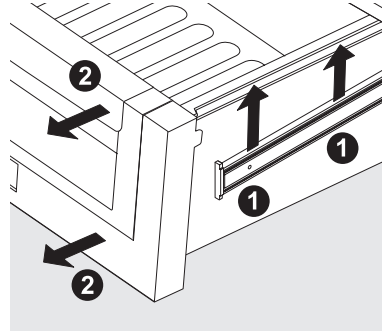

Removing Crisper Drawer

Cool Zone Drawer (select models)

Some models are equipped with a drawer for short-term storage of bulk items. This drawer includes sliding controls for adjusting the humidity inside.

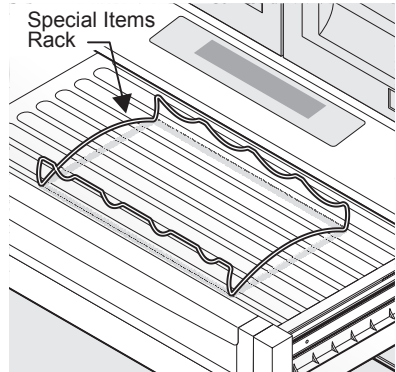

NOTE

Any meat to be kept longer than two days should be frozen. If you store fruits or vegetables in this drawer, set it to a higher humidity.

Perfect Temp™ Drawer (select models)



The Perfect Temp™ Drawer is designed to keep food items at a precise temperature whether cooler, warmer, or the same as the fresh food section of the refrigerator. This drawer features a smooth-glide, ball-bearing system and soft-close functionality so as not to bruise your fruits and vegetables. The thaw setting holds a temperature for thawing frozen foods for 12 hours. At the end of that time, it then switches to the snacks setting to store the thawed food.

To operate:

- 1 To turn on and off, press the drawer's On/Off button. The numeric display will show a temperature between 28° F and 38° F when on and OFF when off.
- 2 Press F/C if you prefer to display Fahrenheit (F), or Celsius (C).
- 3 Press either the up \wedge or down \vee scroll buttons to illuminate the desired item.
- 4 Once an option is selected, the drawer will adjust and maintain the temperature for the setting selected.
- 5 When turned off, the Perfect Temp™ Drawer functions as a standard meat pan. The Perfect Temp™ Drawer is best used for packaged food products. Leafy vegetables and unpackaged fruits are best kept in one of the crisper drawers.
- 6 The three favorite selections provide flexibility to set and store personal temperature selections. The temperature is adjusted up by pressing the + or – buttons. The drawer will store the selected temperature setting until it is changed.
- 7 The control buttons can be locked to prevent accidental changes by pressing the control lock button for three seconds. Deactivate by pressing for three seconds again.

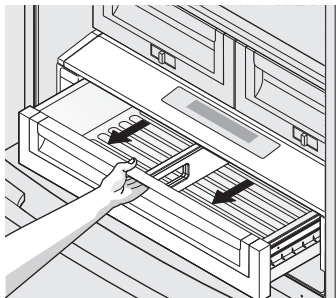

Opening the Drawer



IMPORTANT

DO NOT clean the display area of the Perfect Temp™ Drawer with abrasive or caustic cleaners. Wipe clean with a moist sponge.



CAUTION

The Perfect Temp™ Drawer and cover can be removed for cleaning but the control unit, attached to the right side of the fridge, cannot be removed. Do not immerse the Perfect Temp™ Drawer cover in water or put it in a dishwasher. Clean with a damp cloth or sponge.

To remove the Perfect Temp™ Drawer for cleaning:

- 1 Pull the drawer out until it stops.
- 2 Lift the front slightly and remove the drawer.

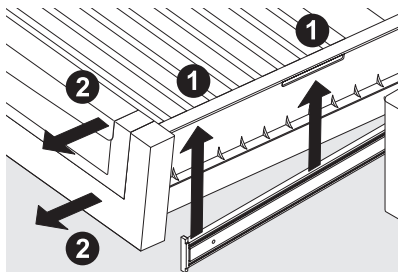

Removing the Drawer



NOTE

When the refrigerator is turned off by pressing the main Wave-Touch™ or IQ-Touch™ on/off button, the Perfect Temp™ Drawer will also be turned off. When the refrigerator is turned back on, the Perfect Temp™ Drawer will resume operations at the temp setting that was set before the refrigerator was turned off.

30 Storage Features

Doors

Storage bins

The doors to your fresh food compartment use a system of modular storage bins. All of these bins are removable for easy cleaning. Some of them have fixed positions, while others can be adjusted to your needs.

Door bins are ideal for storing jars, bottles, cans, and large drink containers. They also enable quick selection of frequently used items.

To change the position of an adjustable door bin:

- 1 Remove all food from bin.
- 2 Grip the bin firmly with both hands and lift it upward.
- 3 Remove the bin.
- 4 Place the bin just above desired position.
- 5 Lower the bin onto supports until locked in place.

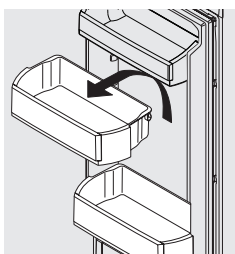

Adjustable Door Bin

Accessories (varies by model)

Tall bottle retainer

The tall bottle retainer keeps tall containers in the bin from falling forward when opening or closing the refrigerator door. To install, insert the ends of the retainer into the holes.

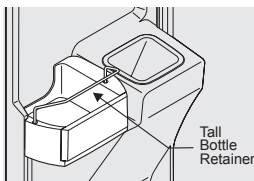

Tall Bottle Retainer

Tilt can bins

The can bins allow you to efficiently and securely store up to eight 12-ounce canned beverages.

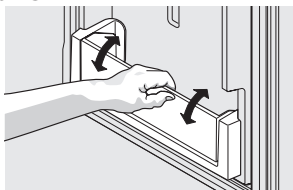

Tilt Can Bin

Freezer Features (varies by model)

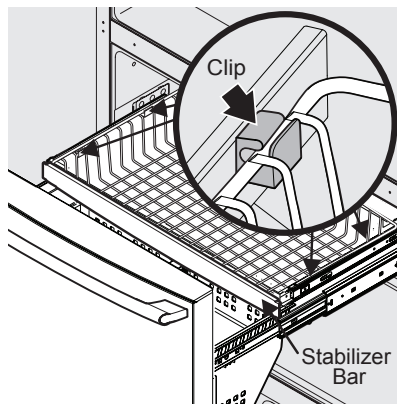

Freezer Baskets

To Remove Upper Freezer Basket

- 1 Find the side where the basket frame is aligned to the clip opening. The basket frame should be aligned to both front and rear clips on the same side (either left or right side).
- 2 If the basket frame is not aligned to the left or right side, push the basket sideways (to either side) until it is aligned.
- 3 By grabbing the basket wire frame close to the frontal clip, pull up to take the basket frame out.
- 4 Grab the basket frame close to the rear clip and pull up until it comes out of the clip.
- 5 Once one side of the basket is off the clips or retainers, slide the basket sideways until the other side of the frame is aligned with the clip openings on the opposite side of the freezer.
- 6 In the same way, pull up the basket frame from the frontal and rear clips until it is out of the clips.
- 7 Remove the basket.

Reverse the steps to reinstall the basket.

NOTE

If basket is not resting on stabilizer bar retainers, the drawer will not close properly.

Removing Freezer Basket Instructions

- 1 Locate the basket clips in the rear corners of the basket and pull them out to remove.
- 2 Open fresh food doors completely.
- 3 Lift the basket up and remove.

Replacing Freezer Basket Instructions

- 1 Place freezer basket back inside the freezer drawer.
- 2 Replace clips by sliding them back into the slots.

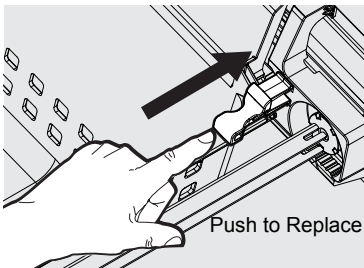
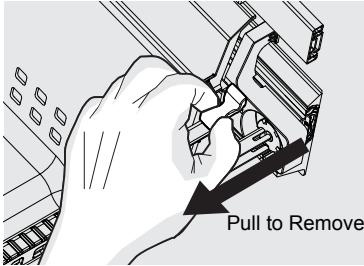
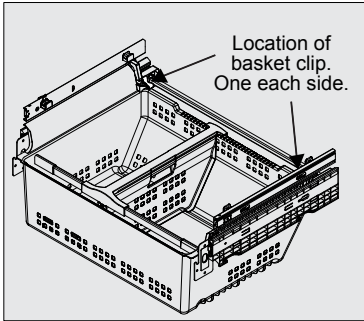

Dividers Removal

Lift up on the front of the upper divider and pull out.

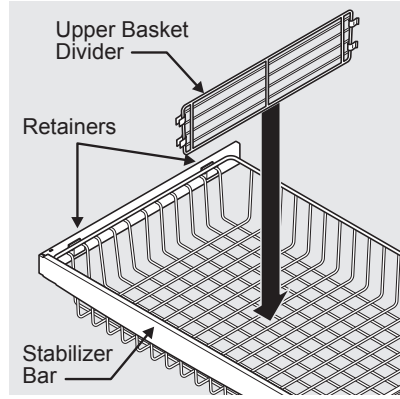

Upper Basket Divider

Squeeze handle and lift up in the center of the divider to move it side-to-side. (The divider cannot be removed.)

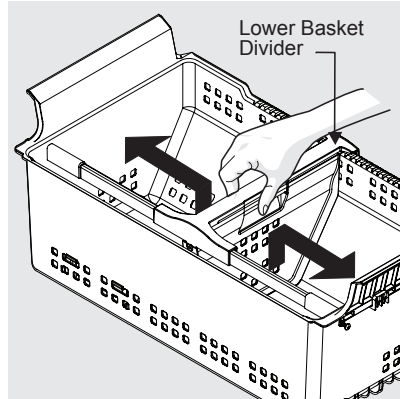

Plastic Lower Basket Divider

Tilt Wire Shelf

The freezer tilt wire shelf (located on the inside of the freezer drawer) is not designed to be removed.

32 Storing Food and Saving Energy

Ideas for storing foods

Fresh food storage

- Keep the fresh food compartment between 37° F and 40° F with an optimum temperature of 37° F.
- Avoid overcrowding the refrigerator shelves, which reduces air circulation and causes uneven cooling.
- Avoid placing food in front of air ports. (See Controls Section for illustration.)

Fruits and vegetables

- Store fruits and vegetables in crisper drawers, where trapped moisture helps preserve food quality for longer time periods.
- Wash items and remove excess water.
- Wrap any items that have strong odors or high moisture content.

Meat

- Wrap raw meat and poultry separately and securely to prevent leaks and contamination of other foods or surfaces.
- Use the Cool Zone drawer or Perfect Temp™ drawer and set to meat/poultry setting for short-term storage. Any meat to be kept longer than two days should be frozen.

Frozen food storage

- Keep the freezer compartment at 0° F or lower.
- A freezer operates most efficiently when it is at least 2/3 full.

Packaging foods for freezing

- To minimize food dehydration and quality deterioration, use aluminum foil, freezer wrap, freezer bags, or airtight containers. Force as much air out of the packages as possible and seal them tightly. Trapped air can cause food to dry out, change color, and develop an off-flavor (freezer burn).
- Wrap fresh meats and poultry with suitable freezer wrap prior to freezing.
- Do not refreeze meat that has completely thawed.

Loading the freezer

- Prior to grocery shopping, activate fast freeze so that on your return you can ensure your newly purchased

food designated for the freezer will be preserved as quickly as possible.

- Activating fast freeze also will help your freezer more efficiently maintain the selected temperature after placing new purchases with pre-existing frozen foods.
- Avoid adding too much warm food to the freezer at one time. This overloads the freezer, slows the rate of freezing, and can raise the temperature of frozen foods.
- Leave a space between packages, so cold air can circulate freely, allowing food to freeze as quickly as possible.

Ideas for saving energy

Installation

- Locate the refrigerator in the coolest part of the room, out of direct sunlight, and away from heating ducts or registers.
- Do not place the refrigerator next to heat-producing appliances such as a range, oven, or dishwasher. If this is not possible, a section of cabinetry or an added layer of insulation between the two appliances will help the refrigerator operate more efficiently.
- Level the refrigerator so that the doors close tightly.

Temperature settings

- Refer to the Controls section for procedures on temperature settings.

Food storage

- Avoid overcrowding the refrigerator or blocking cold air vents. Doing so causes the refrigerator to run longer using more energy and freezing food.
- Cover foods and wipe containers dry before placing them in the refrigerator. This cuts down on moisture build-up inside the unit.
- Organize the refrigerator to reduce door openings. Remove as many items as needed at one time and close the door as soon as possible.
- Do not place a hot container directly on a cold shelf. Remember, such an extreme temperature change may damage the glass.

Understanding the sounds you may hear

Your new, high-efficiency refrigerator may introduce unfamiliar sounds. These sounds normally indicate your refrigerator is operating correctly. Some surfaces on floors, walls, and kitchen cabinets may make these sounds more noticeable.

The following is a list of major components in your refrigerator and the sounds they can cause:

- A Evaporator** Refrigerant through the evaporator may create a boiling or gurgling sound.
- B Evaporator fan** You may hear air being forced through the refrigerator by the evaporator fan.
- C Defrost heater** During defrost cycles, water dripping onto the defrost heater may cause a hissing or sizzling sound. After defrosting, a popping sound may occur.
- D Automatic ice maker** When ice has been produced, you will hear ice cubes falling into the ice bin. Ice maker fan, water valve activation, and refrigerant gas fluid may create sounds from its operation.
- E Electronic control & automatic defrost control** These parts can produce a snapping or clicking sound when turning the cooling system on and off.
- F Condenser fan** You may hear air being forced through the condenser.
- G Compressor** Modern, high-efficiency compressors run much faster than older models. The compressor may have a high-pitched hum or pulsating sound.
- H Water valve** Makes a buzzing sound each time it opens to fill the ice maker.
- I Drain pan** (not removable) You may hear water dripping into the drain pan during the defrost cycle.
- J Condenser** May create minimal sounds from forced air.
- K Motorized Perfect Temp™ drawer damper** May produce a light humming during operation.

- L Ice dispensing paddle** When dispensing ice, you will hear a snapping, clicking, or popping sound.
- M Motorized damper** May produce a light humming during operation.
- N Perfect Temp™ drawer fan** Turns off when door opens or **Perfect Temp™** drawer is turned off.



NOTE

Energy efficient foam in your refrigerator is not a sound insulator.



NOTE

During automatic defrost cycle, a red glow in the back wall vents of your freezer compartment is normal.

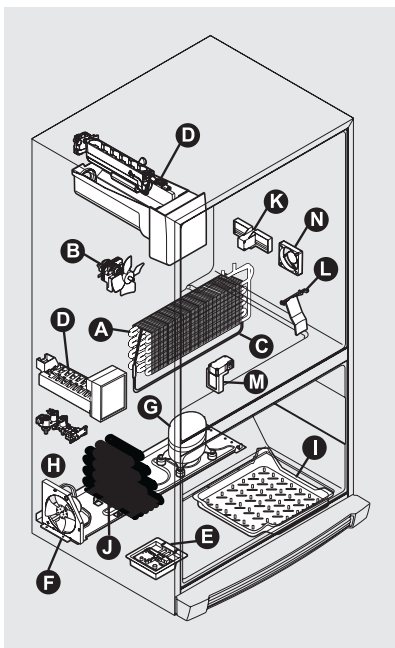

Features vary by model

34 Changing The Water and Air Filters

Locating the Filters

Your refrigerator is equipped with water filtering system. The water filter system filters all dispensed drinking water, as well as the water used to produce ice.

Water Filter

The water filter is located at the top right side of the fresh food compartment.

Replacing the Water Filter

In general, you should change the water filter every six months to ensure the highest possible water quality. Water Filter Status on the user interface prompts you to replace the filter after a standard amount of water (125 gallons/473 liters for PureAdvantage Ultra™) has flowed through the system.

If your refrigerator has not been used for a period of time (during moving for example), change the filter before reinstalling the refrigerator.

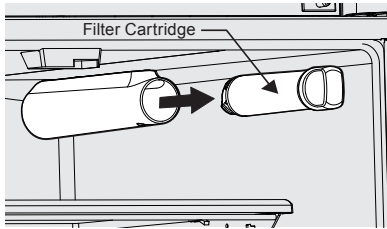

NOTE

When ordering your replacement filter, please reorder the same filter type that is currently in your refrigerator.

More about your Advanced Water Filter



The PureAdvantage Ultra™ ice and water filter system is tested and certified to NSF/ANSI Standards 43, 53 and 401 for the reduction of claims specified on the performance data sheet.

Do not use with water that is microbiologically unsafe or of unknown quality without adequate disinfection before or after the system. Systems certified for cyst reduction may be used on disinfected waters that may contain filterable cysts.

Test & certification results:

- Rated Capacity - 125 gallons/473 liters for PureAdvantage Ultra™ ice and water filter
- Rated service flow - .65 gallons per minute
- Operating Temp: Min. 33°F, Max. 100°F
- Maximum Rated Pressure - 100 pounds per square inch
- Recommended Minimum Operating Pressure: 30 pounds per square inch

To replace your PureAdvantage Ultra™ water filter:

It is not necessary to turn the water supply off to change the filter. Be ready to wipe up any small amounts of water released during the filter replacement.

- 1 Turn Off the ice maker power switch.
- 2 Remove the old filter by rotating it counter-clockwise (to the left) 90 degrees to release it.
- 3 Slide the old filter cartridge straight out of the housing and discard it.
- 4 Unpackage the new filter cartridge. Slide it into the filter housing as far as it will go with the grip end horizontal.
- 5 Push lightly inward on the filter while rotating it clockwise (to the right). The filter will then pull itself inward as it is rotated. Rotate the filter 90 degrees until it stops and the grip end is vertical. You may be able to feel a very light click as the filter locks into place.
- 6 Press a drinking glass against the water dispenser while checking for any leaks at the filter housing. Any spurts and sputters that occur as the system purges air out of the dispenser system are normal.
- 7 Continue dispensing water for 3-4 minutes or until 1.5 gallons of water has flowed through the system. You will likely need to empty and refill your glass several times.
- 8 Turn On the ice maker.
- 9 Press and hold the Water Filter reset button on the control panel for three seconds. When the display changes from Red to Green, the status has been reset.

Air filter

The air filter is located under the utility bin and/or on the inside of the left door above the ice maker chute.

Replacing your PureAdvantage™ air filter

To ensure optimal filtering of refrigerator odors, you should change the air filter every six months (the filter status light on the Touch Panel prompts you to replace the filter after six months).

- 1 Open the air filter door.
- 2 Remove the old filter and discard it.
- 3 Unpack the new filter and slide it into the housing.
- 4 To close the air filter door, push the top and bottom to lock the door closed.
- 5 Press and hold the Air Filter Reset button on the control panel for three seconds. When the display changes from Replace to Good, the status has been reset.

Filter located under the utility bin

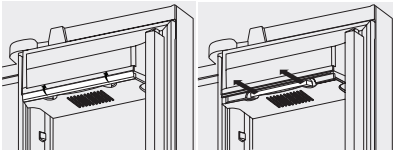

Ordering replacement filters

To order your replacement filters, please visit our online store at www.electroluxappliances.com, by calling toll-free at 800-599-7569, or by visiting the dealer where you purchased your refrigerator. Electrolux recommends that you order extra filters when you first install your refrigerator, and that you replace your filters at least once every six months.

Here is the product number to request when ordering:

Water Filter

PureAdvantage Ultra™ Replacement Cartridge #EWF02

Air Filter

Replacement cartridge, part #EAFCBF

36 Care and Cleaning

Protecting your investment

Keeping your refrigerator clean maintains its appearance and prevents odor build-up. Wipe up any spills immediately and clean the freezer and fresh food compartments at least twice a year.



NOTE

Do not use abrasive cleaners such as window sprays, scouring cleansers, flammable fluids, cleaning waxes, concentrated detergents, bleaches, or cleansers containing petroleum products on plastic parts, interior doors, gaskets, or cabinet liners. Do not use paper towels, scouring pads, or other abrasive cleaning materials.

- Never use metallic scouring pads, brushes, abrasive cleaners, or strong alkaline solutions on any surface.
- Never use CHLORIDE or cleaners with bleach to clean stainless steel.
- Do not wash any removable parts in a dishwasher.
- Always unplug the electrical power cord from the wall outlet before cleaning.



NOTE

If you set your temperature controls to turn off cooling, power to lights and other electrical components will continue until you unplug the power cord from the wall outlet.

- Remove adhesive labels by hand. Do not use razor blades or other sharp instruments which can scratch the appliance surface.
- Do not remove the serial plate. Removal of your serial plate voids your warranty.
- Before moving your refrigerator, raise the anti-tip brackets so the rollers will work correctly. This will prevent the floor from being damaged.



CAUTION

- Pull the refrigerator straight out to move it. Shifting it from side to side may damage flooring. Be careful not to move the refrigerator beyond the plumbing connections.
- Damp objects stick to cold metal surfaces. Do not touch refrigerated surfaces with wet or damp hands.



IMPORTANT

If you store or move your refrigerator in freezing temperatures, be sure to completely drain the water supply system. Failure to do so could result in water leaks when the refrigerator is put back into service. Contact a service representative to perform this operation.

Refer to the guide on the next page for details on caring and cleaning specific areas of your refrigerator.

Care and cleaning tips

Part	Cleaning Agents	Tips and Precautions
Interior & Door Liners	<ul style="list-style-type: none"> • Soap and water • Baking soda and water 	<ul style="list-style-type: none"> • Use two tablespoons of baking soda in one quart of warm water. • Be sure to wring excess water out of sponge or cloth before cleaning around controls, light bulb or any electrical part.
Door Gaskets	<ul style="list-style-type: none"> • Soap and water 	<ul style="list-style-type: none"> • Wipe gaskets with a clean soft cloth.
Drawers & Bins	<ul style="list-style-type: none"> • Soap and water 	<ul style="list-style-type: none"> • Use a soft cloth to clean drawer runners and tracks. • Do not wash any removable items (bins, drawers, etc.) in dishwasher.
Glass Shelves	<ul style="list-style-type: none"> • Soap and water • Glass cleaner • Mild liquid sprays 	<ul style="list-style-type: none"> • Allow glass to warm to room temperature before immersing in warm water.
Toe Grille	<ul style="list-style-type: none"> • Soap and water • Mild liquid sprays • Vacuum 	<ul style="list-style-type: none"> • Remove toe grille (see Installation Instructions). • Vacuum both sides and wipe with sudsy cloth or sponge. Rinse and dry.
Exterior & Handles (Stainless Steel Models Only)	<ul style="list-style-type: none"> • Soap and water • Stainless steel cleaners 	<ul style="list-style-type: none"> • Never use CHLORIDE or cleaners with bleach to clean stainless steel. • Clean stainless steel front and handles with non-abrasive soapy water and a dishcloth. Rinse with clean water and a soft cloth. • Use a non-abrasive stainless steel cleaner. These cleaners can be purchased at most home improvement or major department stores. Always follow manufacturer's instruction. Do not use household cleaners containing ammonia or bleach. • NOTE: Always clean, wipe and dry with grain to prevent scratching. • Wash the rest of the cabinet with warm water and mild liquid detergent. Rinse well and wipe dry with a clean soft cloth.

Vacation and moving tips

Occasion	Tips
Short Vacations	<ul style="list-style-type: none"> • Leave refrigerator operating during vacations of three weeks or less. • Use all perishable items from refrigerator compartment. • Turn automatic ice maker off and empty ice bucket, even if you will only be gone a few days.
Long Vacations	<ul style="list-style-type: none"> • Remove all food and ice if you will be gone one month or more. • Turn the cooling system off (see Controls section for location of On/Off button) and disconnect power cord. • Turn water supply valve to closed position. • Clean interior thoroughly. • Leave both doors open to prevent odors and mold build-up. Block doors open if necessary.
Moving	<ul style="list-style-type: none"> • Remove all food and ice. • If using a handcart, load from the side. • Adjust rollers all the way up to protect them during sliding or moving. • Pad cabinet to avoid scratching surface.

38 Solutions to Common Problems

Before you call...

If you experience a problem with your refrigerator or notice a product behavior or condition that you do not understand, you can usually avoid a call to your service representative by referring to this section for an answer. Beginning with the following table, this information includes common concerns, causes, and suggested solutions.

Concern	Potential Cause	Common Solution
Automatic Ice Maker		
Ice maker is not making any ice.	<ul style="list-style-type: none">• Ice maker is turned off.• Refrigerator is not connected to water line or water valve is not open.• The water supply line is kinked.• The water filter is not seated properly.• The water filter may be clogged with foreign material.• Freezer ice maker wire signal arm is being held up by an item not allowing it to go in the on or down position.	<ul style="list-style-type: none">• Turn on ice maker. For the fresh food ice maker, press ice maker on-off once. For the freezer ice maker, lower the arm to turn the ice maker on, or raise it and snap it in its upper position to turn the ice maker off.• Connect the unit to the household water supply and ensure the water valve is open.• Ensure that the supply line does not kink when the refrigerator is pushed into place against the wall.• Remove and re-install the water filter. Be sure to rotate it fully into the locked position position.• If water dispenses slowly or not at all, or if the filter is six months old or older, it should be replaced.• Move any item or frozen ice cubes that may block the signal arm from being in the on or down position. Additionally, the ice bin itself may be out of position so that it prevents the signal arm from dropping all the way down. Be sure the bin is pushed all the way to the rear of the shelf. See Automatic Ice Maker-Freezer section in manual.

Concern	Potential Cause	Common Solution
Automatic Ice Maker (Cont'd)		
Ice maker is not making enough ice.	<ul style="list-style-type: none"> • Ice maker is producing less ice than you expect. • The water filter may be clogged with foreign material. • The water supply line is kinked. • Saddle valve on cold water pipe is clogged or restricted by foreign material. • Heavy traffic, opening or closing of the doors excessively. • Freezer control is set too warm (freezer ice maker). • Water pressure is extremely low. Cut-off and cut-on pressures are too low (well systems only). • Reverse osmosis system is in regenerative phase. 	<ul style="list-style-type: none"> • The ice maker will produce approximately 2.3 pounds of ice (fresh food ice maker) and 2.5 pounds of ice (freezer ice maker) every 24 hours depending on usage conditions. • If water dispenses slower than normal, or if the filter is six months old or older, it should be replaced. • Ensure that the supply line does not kink when the refrigerator is pushed into place against the wall. • Turn off household water line valve. Remove valve. Ensure that valve is not a self-piercing saddle valve. Clean valve. Replace valve if necessary. • Press Fast Freeze to temporarily increase ice production rate. (Freezer ice maker only.) • Set freezer control to colder setting to improve performance of the ice maker (freezer ice maker). Allow 24 hours for temperature to stabilize. • Have someone turn up the cut-off and cut-on pressure on the water pump system (well systems only). • It is normal for a reverse osmosis system to be below 20 psi during the regenerative phase.
Freezer ice maker will not stop making ice (select models).	<ul style="list-style-type: none"> • Ice maker wire signal arm is being held down by a package in the freezer that has fallen against ice maker. 	<ul style="list-style-type: none"> • Move any item or frozen ice cubes that may block the signal arm from being in the off or upward position. See Automatic Ice Maker-Freezer section in manual.
Ice cubes are freezing together.	<ul style="list-style-type: none"> • Ice cubes are not being used frequently enough or interruption of power for prolonged time. • Ice cubes are hollow (shells of ice with water inside). The hollow cubes break open in the bin and leak their water onto existing ice, which causes it to freeze together. 	<ul style="list-style-type: none"> • Remove ice container and discard ice. The ice maker will produce fresh supply. Ice should be used at least twice weekly to keep the cubes separated. • This generally occurs when the ice maker does not get enough water. This is usually the result of a clogged water filter or restricted water supply. Replace the water filter and if the condition still occurs check for a Saddle Valve, water valve not turned on all the way or kinked water supply line.

40 Solutions to Common Problems

Concern	Potential Cause	Common Solution
Dispenser (Ice & Water)		
Dispenser will not dispense ice.	<ul style="list-style-type: none"> • There is no ice in the bin to be dispensed. • The refrigerator doors are not completely closed. • Dispenser paddle has been pressed too long and the dispenser motor has overheated. 	<ul style="list-style-type: none"> • See the "Ice maker is not making any ice" section above. • Be sure the refrigerator doors are completely closed. • The motor overload protector will reset in about three minutes and then ice can be dispensed.
Ice dispenser is jammed.	<ul style="list-style-type: none"> • Ice has melted and frozen around auger due to infrequent use, temperature fluctuations, and/or power outages. • Ice cubes are jammed between ice maker and back of ice container. 	<ul style="list-style-type: none"> • Remove ice container, thaw, and empty the contents. Clean container, wipe dry, and replace in proper position. When new ice is made, dispenser should operate. • Remove ice cubes that are jamming the dispenser.
Dispenser will not dispense water.	<ul style="list-style-type: none"> • Water filter not seated properly. • Water filter is clogged. • Household water line valve is not open. 	<ul style="list-style-type: none"> • Remove and reinstall the water filter. For PureAdvantage Ultra, be sure to rotate it to the right until it stops and the grip end is vertical. • Replace filter cartridge. Be sure to rotate it to the right until it stops and the grip end is vertical. • Open household water line valve. See CONCERN column AUTOMATIC ICE MAKER.
Water not cold enough.	<ul style="list-style-type: none"> • The water dispensing system is not designed to chill water. 	<ul style="list-style-type: none"> • Add ice to cup or container before dispensing water.
Water has an odd taste and/or odor.	<ul style="list-style-type: none"> • Water has not been dispensed for an extended period of time. • Unit not properly connected to cold water line. 	<ul style="list-style-type: none"> • Draw and discard 10-12 glasses of water to freshen the supply. • Connect unit to cold water line that supplies water to the kitchen faucet.

Concern	Potential Cause	Common Solution
Opening/Closing Of Doors/Drawers		
Door(s) will not close.	<ul style="list-style-type: none"> • Door was closed too hard, causing other door to open slightly. • Refrigerator is not level. It rocks on the floor when moved slightly. • Refrigerator is touching a wall or cabinet. 	<ul style="list-style-type: none"> • Close both doors gently. • Ensure floor is level and solid, and can adequately support the refrigerator. Contact a carpenter to correct a sagging or sloping floor. • Ensure floor is level and solid, and can adequately support the refrigerator. Contact a carpenter to correct a sagging or sloping floor.
Drawers are difficult to move.	<ul style="list-style-type: none"> • Food is touching shelf on top of drawer. • Track that drawers slide on is dirty. 	<ul style="list-style-type: none"> • Remove top layer of items in drawer. • Ensure drawer is properly installed on track. • Clean drawer, rollers, and track. See Care & Cleaning.
Running of Refrigerator		
Compressor does not run.	<ul style="list-style-type: none"> • Freezer control is set to "OF". • Refrigerator is in defrost cycle. • Plug at electrical outlet is disconnected. • House fuse blown or tripped circuit breaker. • Power outage. 	<ul style="list-style-type: none"> • Set freezer control. • This is normal for a fully automatic defrost refrigerator. The defrost cycle occurs periodically, lasting about 30 minutes. • Ensure plug is tightly pushed into outlet. • Check/replace fuse with a 15 amp time-delay fuse. Reset circuit breaker. • Check house lights. Call local electric company.
Refrigerator seems to run too much or too long.	<ul style="list-style-type: none"> • Your variable speed compressor is designed to run 100% of the time except during the defrost cycle. At times it will run faster, such as after a defrost cycle. 	<ul style="list-style-type: none"> • It is normal for the compressor to run continuously except during defrost mode.
Digital Temperature Setting Display		
Digital temperature displays an error.	<ul style="list-style-type: none"> • Electronic control system has detected a performance problem. 	<ul style="list-style-type: none"> • Call your Electrolux service representative, who can interpret any messages or number codes flashing on the digital displays.

42 Solutions to Common Problems

Concern	Potential Cause	Common Solution
Water/Moisture/Frost Inside Refrigerator		
Moisture collects on inside of refrigerator walls.	<ul style="list-style-type: none"> Weather is hot and humid. Flipper mullion 	<ul style="list-style-type: none"> The rate of frost buildup and internal sweating increases. Adjust flipper mullion. (See "To adjust the flipper mullion" in the Installation section.)
Water collects on bottom side of drawer cover.	<ul style="list-style-type: none"> Vegetables contain and give off moisture. 	<ul style="list-style-type: none"> It is not unusual to have moisture on the bottom side of the cover. Move humidity control (some models) to lower setting.
Water collects in bottom of drawer.	<ul style="list-style-type: none"> Washed vegetables and fruit drain while in the drawer. 	<ul style="list-style-type: none"> Dry items before putting them in the drawer. Water collecting in bottom of drawer is normal.
Water/Moisture/Frost Outside Refrigerator		
Moisture collects on outside of refrigerator or between doors.	<ul style="list-style-type: none"> Weather is humid. 	<ul style="list-style-type: none"> This is normal in humid weather. When humidity is lower, the moisture should disappear.
Food in Fresh Food Compartment		
Food is freezing.	<ul style="list-style-type: none"> Temperature setting is too low. Temperature sensor is covered by food (right side of fresh food area). Food is covering the air ports. 	<ul style="list-style-type: none"> Move the setting to a higher degree. Allow space for air flow to the sensor. Allow space between the air ports and the food.

Major Appliance Warranty Information

Your appliance is covered by a one year limited warranty. For one year from your original date of purchase, Electrolux will repair or replace any parts of this appliance that prove to be defective in materials or workmanship when such appliance is installed, used, and maintained in accordance with the provided instructions. In addition, the cabinet liner and sealed refrigeration system (compressor, condenser, evaporator, dryer or tubing) of your appliance is covered by a two through five year limited warranty. During the 2nd through 5th years from your original date of purchase, Electrolux will repair or replace any parts in the cabinet liner and sealed refrigeration system which prove to be defective in materials or workmanship when such appliance is installed, used, and maintained in accordance with the provided instructions.

Exclusions

This warranty does not cover the following:

1. Products with original serial numbers that have been removed, altered or cannot be readily determined.
2. Product that has been transferred from its original owner to another party or removed outside the USA or Canada.
3. Rust on the interior or exterior of the unit.
4. Products purchased "as-is" are not covered by this warranty.
5. Food loss due to any refrigerator or freezer failures.
6. Products used in a commercial setting.
7. Service calls which do not involve malfunction or defects in materials or workmanship, or for appliances not in ordinary household use or used other than in accordance with the provided instructions.
8. Service calls to correct the installation of your appliance or to instruct you how to use your appliance.
9. Expenses for making the appliance accessible for servicing, such as removal of trim, cupboards, shelves, etc., which are not a part of the appliance when it is shipped from the factory.
10. Service calls to repair or replace appliance light bulbs, air filters, water filters, other consumables, or knobs, handles, or other cosmetic parts.
11. Pickup and delivery costs; your appliance is designed to be repaired in the home.
12. Surcharges including, but not limited to, any after hour, weekend, or holiday service calls, tolls, ferry trip charges, or mileage expense for service calls to remote areas, including the state of Alaska.
13. Damages to the finish of appliance or home incurred during transportation or installation, including but not limited to floors, cabinets, walls, etc.
14. Damages caused by: services performed by unauthorized service companies; use of parts other than genuine Electrolux parts or parts obtained from persons other than authorized service companies; or external causes such as abuse, misuse, inadequate power supply, accidents, fires, or acts of God.

DISCLAIMER OF IMPLIED WARRANTIES; LIMITATION OF REMEDIES

CUSTOMER'S SOLE AND EXCLUSIVE REMEDY UNDER THIS LIMITED WARRANTY SHALL BE REPAIR OR REPLACEMENT AS PROVIDED HEREIN. CLAIMS BASED ON IMPLIED WARRANTIES, INCLUDING WARRANTIES OF MERCHANTABILITY OR FITNESS FOR A PARTICULAR PURPOSE, ARE LIMITED TO ONE YEAR OR THE SHORTEST PERIOD ALLOWED BY LAW, BUT NOT LESS THAN ONE YEAR. ELECTROLUX SHALL NOT BE LIABLE FOR CONSEQUENTIAL OR INCIDENTAL DAMAGES SUCH AS PROPERTY DAMAGE AND INCIDENTAL EXPENSES RESULTING FROM ANY BREACH OF THIS WRITTEN LIMITED WARRANTY OR ANY IMPLIED WARRANTY. SOME STATES AND PROVINCES DO NOT ALLOW THE EXCLUSION OR LIMITATION OF INCIDENTAL OR CONSEQUENTIAL DAMAGES, OR LIMITATIONS ON THE DURATION OF IMPLIED WARRANTIES, SO THESE LIMITATIONS OR EXCLUSIONS MAY NOT APPLY TO YOU. THIS WRITTEN WARRANTY GIVES YOU SPECIFIC LEGAL RIGHTS. YOU MAY ALSO HAVE OTHER RIGHTS THAT VARY FROM STATE TO STATE.

If You Need Service

Keep your receipt, delivery slip, or some other appropriate payment record to establish the warranty period should service be required. If service is performed, it is in your best interest to obtain and keep all receipts. Service under this warranty must be obtained by contacting Electrolux at the addresses or phone numbers below.

This warranty only applies in the USA, Puerto Rico and Canada. In the USA and Puerto Rico, your appliance is warranted by Electrolux Major Appliances North America, a division of Electrolux Home Products, Inc. In Canada, your appliance is warranted by Electrolux Canada Corp. Electrolux authorizes no person to change or add to any obligations under this warranty. Obligations for service and parts under this warranty must be performed by Electrolux or an authorized service company. Product features or specifications as described or illustrated are subject to change without notice.

USA
1-877-435-3287
Electrolux Major Appliances North America
10200 David Taylor Drive
Charlotte, NC 28262

Canada
1-800-265-8352
Electrolux Canada Corp.
5855 Terry Fox Way
Mississauga, Ontario,
Canada L5V 3E4