



APPLIANCES FOR LIVING

CAGH6000B

CAGH7000B

CAGH9000B

OPERATION MANUAL

 **ARTUSI**
THE ART OF LIVING

Congratulations, you are now the proud owner of an ARTUSI cooking appliance. Thank you for purchasing ARTUSI and welcome to the ARTUSI Family.

This instruction manual has been specially created to inform you of the full range of features your ARTUSI appliance has to offer and serves as an introduction to getting the very best out of your ARTUSI appliance.

We present detailed information on each of the features your ARTUSI appliance consists of. Once you have read this section you will be able to choose the most appropriate settings for your appliance when cooking different types of food.

We ask you to read the instructions in this booklet very carefully as this will allow you to get the best results from using your appliance. KEEP THE DOCUMENTATION OF THIS PRODUCT FOR FUTURE REFERENCE.

TO REGISTER YOUR PRODUCT WITH ARTUSI, PLEASE FILL OUT THE WARRANTY CARD AT THE END OF THIS BOOKLET AND POST IT TO: **REPLY PAID 83617**
LEICHHARDT NSW 2040

Dear Artusi Customer, please read this user manual carefully before using the product and, keep it permanently at your disposal.

Note: This user manual is prepared for more than one model. Some of the features specified in this Manual may not be available on your appliance.

All our appliances are only for domestic use, not for commercial use. Products marked with (*) are optional.

“THIS APPLIANCE SHALL BE INSTALLED IN ACCORDANCE WITH THE REGULATIONS FORCE AND ONLY USED IN A WELL VENTILATED SPACE. READ THE INSTRUCTIONS BEFORE INSTALLING OR USING THIS APPLIANCE”

“Conforms with the WEEE Regulations.”

Installation and User manual

Contents

Safety	1
Product description	4
Installation	6
Start using your appliance	11
Maintenance and troubleshooting	13

This manual explains the proper installation and use of your appliance, please read it carefully before using even if you are familiar with the product. The manual should be kept in a safe place for future reference. In case of failure, only the Authorized Technical Service may repair this hob. Otherwise the guarantee will be null and void.

Warning

General Safety

- The appliance may only be installed and connected by licensed gasfitters / authorized persons.
- Built-in appliances may only be used after they have been built in to suitable cabinets and work surfaces that meet local authority standards.
- Repairs to the appliance must only be carried out by trained registered authorized service persons / engineers.
- Consult the reference data label before making the electrical connections. It is located on the underside of the appliance.
- The electrical connections must be made by specialist installers to the local legal and regulatory requirements.
- If the cable is damaged in any way it must be replaced by the manufacturer or after sale service or by authorized technical staff.
- **NEVER USE OR STORE FLAMMABLE MATERIALS IN THE APPLIANCE STORAGE DRAWER OR NEAR THIS APPLIANCE.**
- **NEVER SPRAY AEROSOLS IN THE VICINITY OF THIS APPLIANCE WHILE IT IS IN OPERATION.**
- **ALTERATION OR MODIFICATION OF THIS APPLIANCE IS FORBIDDEN.**
- **USE OF THIS APPLIANCE AS A SPACE HEATER IS VERY DANGEROUS AND MAY RESULT IN INJURY OR DEATH.**

Correct Use

- People including children, who, because of their physical, sensory or mental capabilities or their inexperience or ignorance are not able to use the device safely, should not use this device without supervision or instruction by a responsible person.
- Only use this appliance for normal domestic cooking and frying of food. It is not for commercial use.
- The appliance must not be used as a work surface or as a storage surface.
- Additions or modifications to the appliance are not permitted.
- Do not place or store flammable liquids, highly inflammable materials or fusible objects

(e.g. plastic film, plastic, aluminum) on or near the appliance.

- Never heat empty pans on the appliance.

Children's Safety

- The cooking zones will become hot when you cook. Always keep small children away from the appliance.
- The appliance is not intended for use by young children or infirm persons without supervision.
- Young children must supervised to ensure that they do not play with the appliance.

Safety During Use

- There is the risk of burns from the appliance if used carelessly.
- Keep all cables away from the appliance and hot cookware
- Warning! Fire Hazard! Overheated fats and oils can ignite very quickly. Never leave oil heating unattended.
- Risk of burns! Do not place objects made of metal, such as knives, forks, spoons and saucepan lids on the surface, as they can get hot.

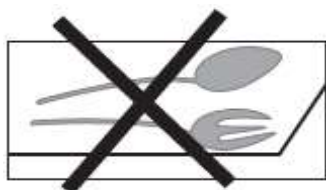

- **Unsuitable for use in a marine environment**
- **The appliance can be used in freezing conditions.**

Safety Instructions

Safety When Installed

- This hotplate must be installed in accordance with:
AS 5601 - Gas Installations (for Australia) – current edition
NZS 5261 – Code of Practice for the Installation of Gas Burning Appliances and Equipment (for New Zealand) This standard may not be current.
Local gas fitting regulations
AS/NZS 3000 – Electrical Installations (Wiring Rules)
Building codes
Any other relevant statutory regulations.
- Check the gas type label on the underside of the hotplate, adjacent to the gas connection

to ensure it corresponds to the installation gas supply. If in doubt contact the supply authority.

- The power supply cord (supplied) must not touch any hot surfaces and must be placed so that its temperature does not exceed 75 degrees at any point along its length.
- Check for leaks using soapy solution, never a naked flame, after connecting to gas.
- Where a flexible hose assembly is used, ensure it is approved to AS/NZS 1869, Class B 10mm diameter and no more than 1.0metre in length. Any hose assembly used must be restrained from accidental contact with the flue outlet of an under bench oven.

How To Avoid Damage To The Appliance

- Do not use the cooking zones with empty cookware or without cookware.
- The ventilation gap of 5mm between the worktop and front of the unit underneath must not be covered.
- ALTERATION or MODIFCATION OF THIS APPLIANCE VOIDS THE WARRANTY.

Safety When Cleaning

- Switch off the cooled appliance before cleaning.
- For safety reasons, the cleaning of the appliance with steam jet or high pressure cleaning equipment is not permitted.



Disposing Of The Device

Take it to an electrical and electronic waste recycling and reuse centre. A label has been put on the device, its instructions manual, or the package. The device has been manufactured of recyclable material.

Ask your local environmental care authority for information on location of such facilities.



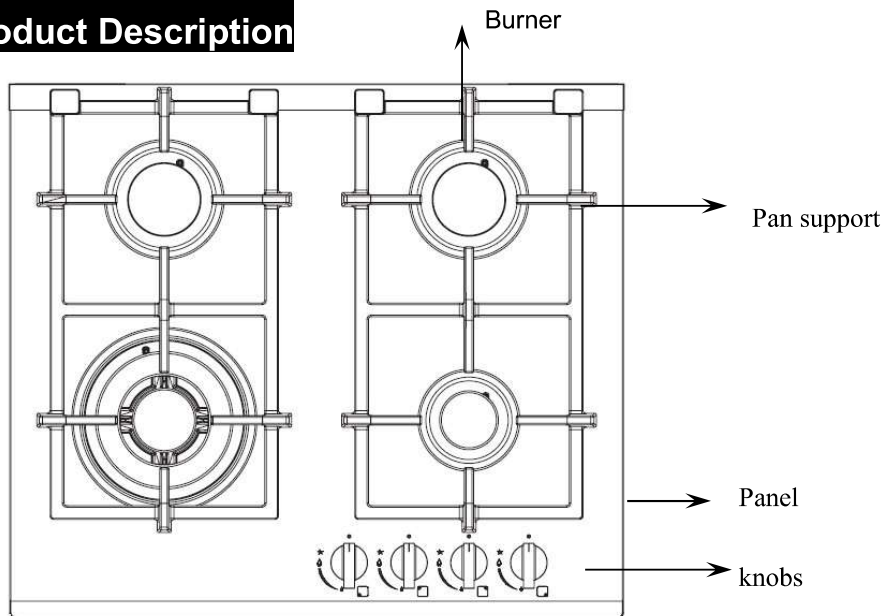

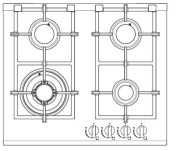
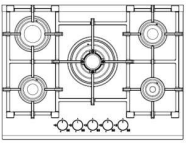
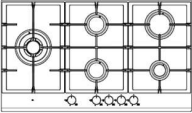
Product Description

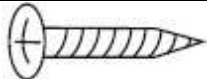

No	Model	Burner*	FFD	Pan supports	Knob position	Total gas consumption	Over view
1	CAGH6000B	1W+2SR+1A	With	Cast Iron	Front	LPG: 29.6MJ/h	
						NG: 29.0MJ/h	
2	CAGH7000B	1W+1R +2SR+1A	With	Cast Iron	Front	LPG: 39.6MJ/h	
						NG: 39.0MJ/h	
3	CAGH9000B	1W+1R +2SR+1A	With	Cast Iron	Front	LPG: 39.6MJ/h	
						NG: 39.0MJ/h	

*Note:

For burner: W=Triple Ring Wok burner, R=Rapid burner, SR=Semi-Rapid burner, A=Auxiliary burner

Accessory Name	Picture (for reference only, physical unit maybe different)	Quantity
User Manual		1
Sealing tape		1 roll
Additional labels	You have an additional rating label in accessory bag, attach it to a surface where it can be easily read e.g. inside surface of adjacent cupboard	1 set
Installation clip		4 sets
Screws ST4.2x24		4 pcs
LPG Injectors		4 pcs
Elbow & Washers		1 Elbow, 3 washers
Natural gas regulator		1

Technical Specifications

Model	Product Dimensions (h x w x d) mm	Cut-out Size (w x d)mm	Electrical Connection	Rated Input Power
CAGH6000B	584x510x100	552 x 470	220-240V/50Hz	0.5W
CAGH7000B	684x510x100	552 x 470	220-240V/50Hz	0.5W
CAGH9000B	874x510x100	827 x 475	220-240V/50Hz	0.5W

Installation

Before Installation:

- Before cutting into any bench tops, ensure the minimum clearances to walls, adjacent surfaces and overhead surfaces required by the relevant gas appliance installation code (see above) will comply. Dimensions are specified in millimeters (mm)

Overhead cupboards and range hood = 600 mm.

Side and rear clearance = 200 mm to any burner edge.

Overhead exhaust/ceiling fan = 750 mm

Horizontal surfaces adjacent the hob = less than or equal to the hob height.

Ensure there is sufficient clearance to fit the regulator and/or flexible hose connection with the hotplate in the installed position.

Before the appliance is installed into the cabinet, please make sure any transit protection materials are removed.

NOTE: This appliance is a built in appliance, the immediate surrounds of the appliance material must be non-combustible materials or combustible material with heat resistance value higher than 90°C.

When you have installed the hob, make sure that

- The GPO (general purpose outlet) must always be in an accessible position.
- The supply connection point, test point and natural gas regulator adjustment screw (for Natural gas installation) are accessible for testing and/or adjustment with the hotplate in the installed position.

TO BE INSTALLED ONLY BY AN AUTHORIZED PERSON.

1. Cupboard Cutting

Bench top thickness, 30– 40 mm (3 – 4 cm).

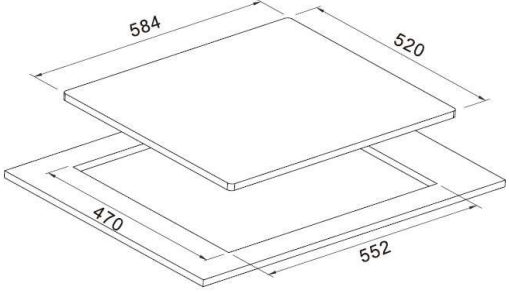
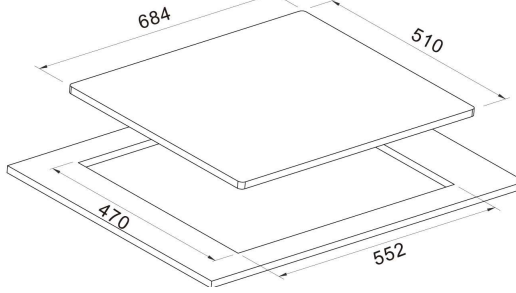
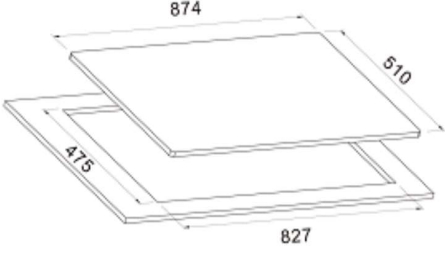
 <p>mm</p>	 <p>mm</p>
CAGH6000B	CAGH7000B
 <p>mm</p>	
CAGH9000B	

2. Place Burner Box

Apply the adhesive sealing tape to the underside lip of the burner box. Shown at G opposite.

Place burner box into cutout hole and fit clamping brackets to clamp the hotplate to the bench.

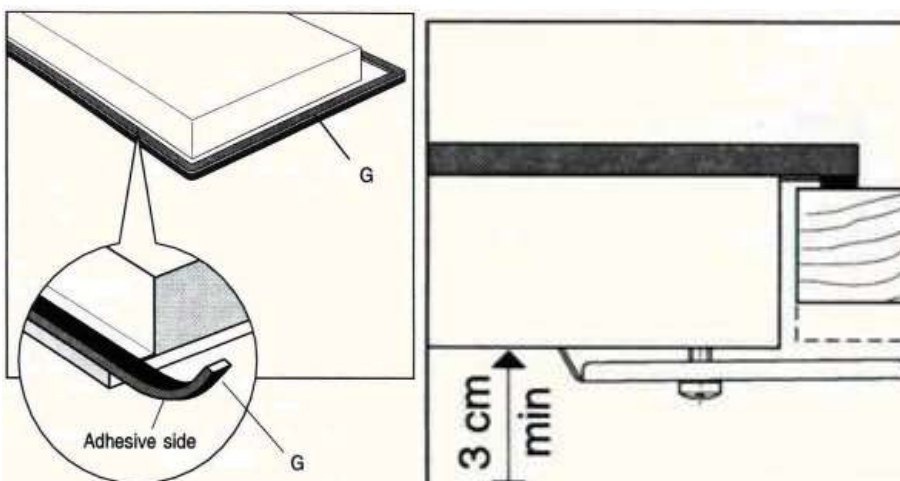

3. Fit Burners And Trivet.

Replace burners and ensure they are correctly repositioned over the ignitor (S) and thermocouple (T). The ignitor (S) must be clean for trouble free sparking. Test burner ignition and burner flame for correct operation, If burner is placed correctly it will not rotate on its supports..

The Triple Ring (Wok) burner (diagrams below) does not fit over the igniter or thermocouple but must be placed on its supports. Make sure trivet is fitted onto its locator on burners and can't rotate after assembled.

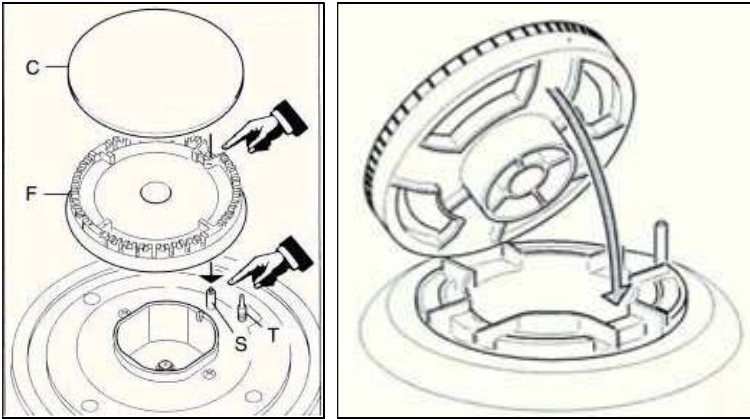

3. Electrical Connection

Install a 10 amp general purpose outlet (GPO) in accordance with relevant electrical standards and/or codes of practice applicable.

The power supply cord (supplied) must not touch against any hot surfaces and must be placed so that its temperature does not exceed 75°C at any point along its length.

After having installed the hotplate, the GPO must always be in an accessible position.

Wiring diagram

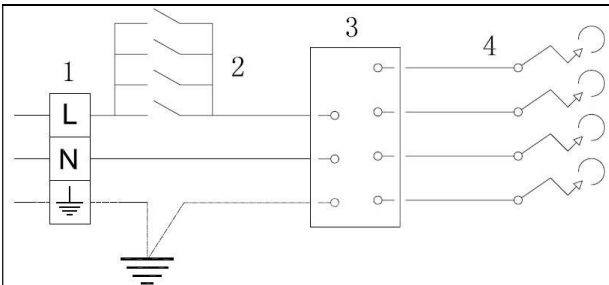

CAGH6000B

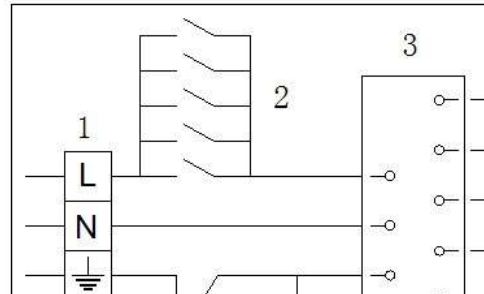

CAGH7000B, CAGH9000B

4. Gas Connection

Install in accordance with relevant gas standards and/or codes of practice applicable.

Connect the elbow fitting to the appliance gas manifold connection, and check that seals between the elbow and manifold connection are in place and in good condition.

- For Natural gas: connect the natural gas appliance regulator (pictured opposite) with integral test point using approved gas thread tape or compound to the elbow fitting.
- For Universal LPG: see **"SETTING THE GAS PRESSURE"**



Ensure the supply connection point, test point and natural gas regulator adjustment screw (for Natural gas installation) are accessible for testing and/or adjustment with the hotplate in the installed position.

Where a flexible hose assembly is used, ensure it is approved to AS/NZS 1869, Class B. Any hose assembly used must be restrained from accidental contact with the flue outlet of an under bench oven. This hose assembly shall be suitable for connection to a fixed consumer piping outlet located as follows:

Hotplates at a point 800 mm to 850 mm above the floor and in the region outside the width of the appliance to a distance of 250 mm.

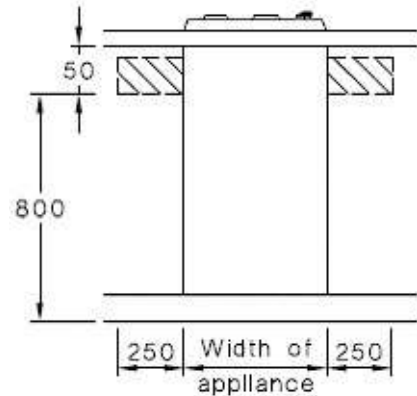

Note: Hose diameter 10mm, Length 1000mm(Maximum)



Inlet connection region for flexible hose

After connecting to gas, check for leaks using soapy solution, never a naked flame.

Fit the duplicate data plate (supplied in separate bag) on a surface adjacent to the hotplate, for example, the inside of the cupboard door so it is clearly visible for any service technician.

SETTING THE GAS PRESSURE:

Fit a manometer with a 6 mm rubber hose to the test point on the regulator (for natural gas).

Natural Gas (the appliance test point is located at the regulator)

The supplied regulator must be fitted to the appliance inlet connection. Gas pressure must be adjusted to 1.0kPa when approximately 50% of the burners are on high flame.

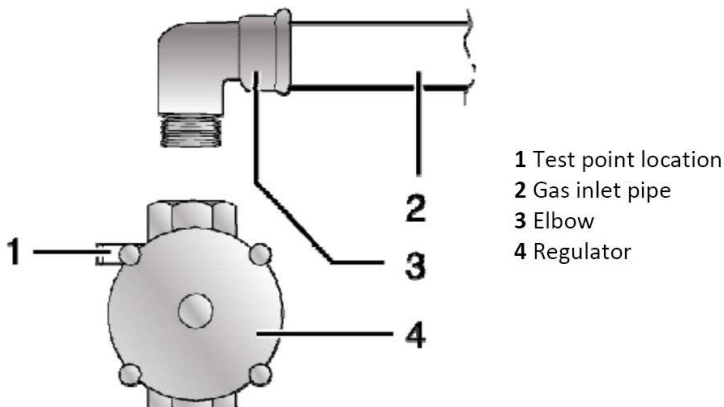

Universal LPG(the appliance test point is located at the injector)

Gas pressure must be checked to confirm the appliance operating pressure is 2.75kPa, the appliance test point is the rapid burner injector as shown below.

1. Disconnect power;
2. Light the auxiliary burner and set to high flame. Ensure all other burners are off.
3. Zero manometer, then apply flexible tubing to seal over the Rapid burner injector, hold securely in place and check the gas pressure by pressing in the corresponding burner control knob in, then turning to high flame position.
4. If the pressure is 2.75kPa, reassemble the burner and perform the final checks as per this instruction

manual.

- If the pressure is not 2.75kPa, disconnect the appliance and check/adjust/replace the LPG cylinder regulator(s) as appropriate in accordance with AS/NZS 5601.

*Patent 2015101170. For enquires contact Gas Approval Consulting Pty Ltd
Tinon licence 036 for SAI-400193*

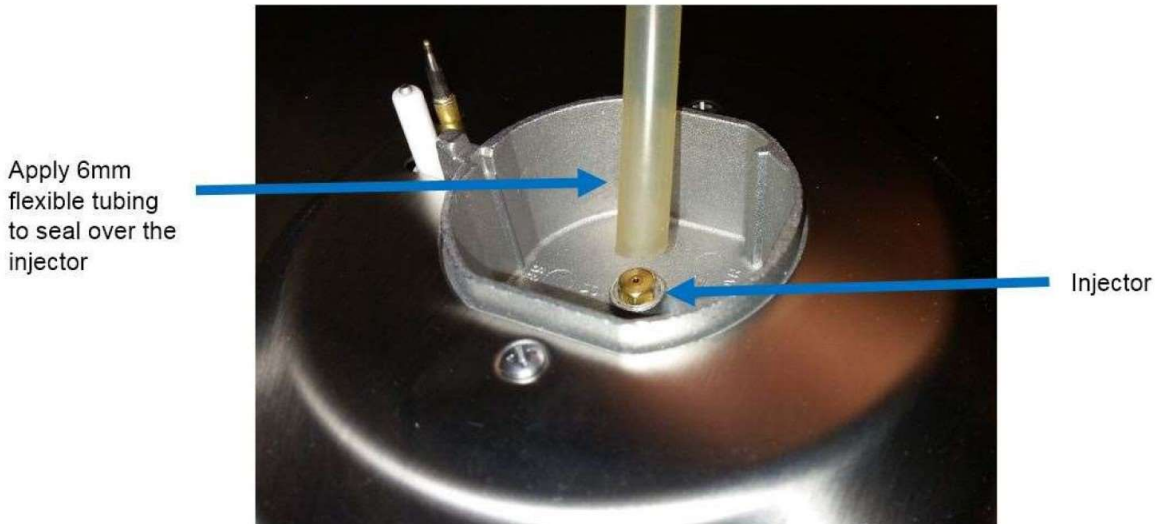

Patent 2015101170. For enquires contact Gas Approval Consulting Pty Ltd

Alternative: If the appliance is supplied with an LPG test point adapter; then this component maybe fitted to the inlet connection for the purpose of a test point.

ADJUSTING THE BURNER MINIMUM FLAME HEIGHT:

NOTE: This adjustment can only be performed by the installer or by authorised service personnel.

The minimum burner flame is factory adjusted for the gas type stated on the gas type label adjacent to the gas connection and should not require adjustment. Adjustment may be required if the hotplate has been converted from Natural gas to Universal LPG or vice versa.

GAS CONVERSION INSTRUCTIONS:

The manufacturers servicing instructions detail how authorised personnel may convert the hotplate from Natural gas to Universal LPG or from Universal LPG to Natural gas. Contact the manufacturer or agent as required.

ADJUSTED FOR NATURAL GAS 1.0kPa			ADJUSTED FOR ULPG 2.75KPa		
NOZZLES DIAMETER	mm	Gas consumption, MJ/h	NOZZLES DIAMETER	mm	Gas consumption, MJ/h
WOK	1.70	13.0	WOK	0.98	13.0
Rapid	1.40	10.0	Rapid	0.90	10.0
SEMI RAPID	1.10	6.0	SEMI RAPID	0.7	6.3
AUXILIARY	0.90	4.0	AUXILIARY	0.55	4.0
Replacement of the nozzles must be performed by a qualified person. Once the nozzles have been replaced this label must to be affixed to the name plate of the appliances.			Replacement of the nozzles must be performed by a qualified person. Once the nozzles have been replaced this label must to be affixed to the name plate of the appliances.		
Natural Gas regulator is to be fitted and adjusted			Change the NG regulator to LPG by a qualified person.		

Start Using Your Appliance

CAGH6000B

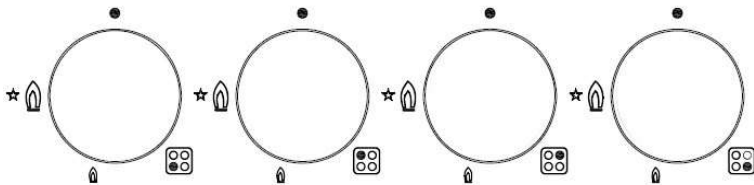

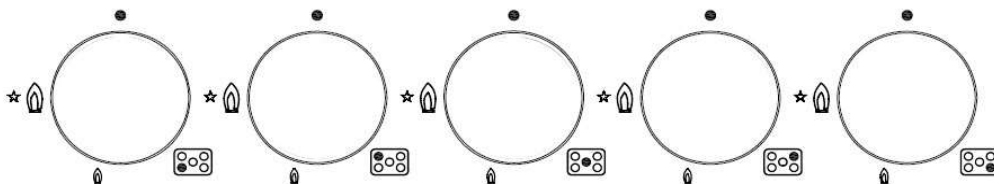

CAGH7000B,

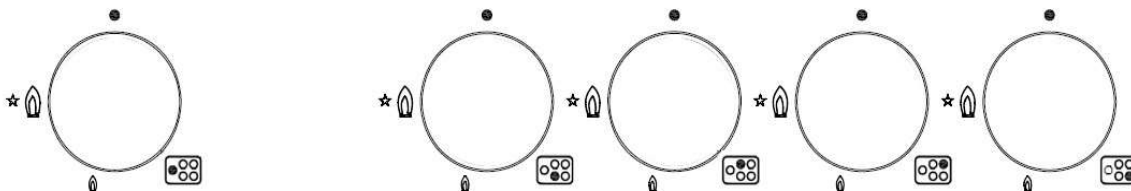

CAGH9000B



Description	Explanation
 Zone indicators	These show which zone is under control.
Flame power	Flame power of the zones,  is the lowest and  is the highest.

The hotplates are fitted with mains powered electronic spark igniters, so must be connected to mains power supply (i.e. nominal 220~240 V ac) to operate. If power is not available, the hotplate will still work but the burners will have to be lit with a match or similar.

Depressing the gas control knob of any burner will activate the spark ignition for all burners. To light the burner, turn the gas control knob to the High Flame setting of the burner to be lit, while at the same time depressing the gas control knob to activate the spark ignition.

Once the burner is light, continue to depress the gas control knob for 5 – 10 seconds to allow the flame safeguard to activate. If when you release the gas control knob, the burner flame goes out the flame safeguard has not heated up enough so repeat the ignition procedure after waiting 1 minute for gas to disperse. If problems

with burner lighting persist, refer to the TROUBLESHOOTING section of these instructions.

If power is not available, light a match or similar, then turn the gas control knob for the burner to be lit, to the High Flame setting. Once again if problems with burner lighting persist, refer to the TROUBLESHOOTING section of these instructions.

When burner lights, adjust desired flame height. On finishing, turn control knob to off position marked with a black DOT.

BURNER AND UTENSIL CHOICE

The **maximum** utensil (pan) diameters in millimeters (mm) for each burner are:

1. For Natural Gas hotplates

Auxiliary (small) and Semi-Rapid (medium) = 195 mm

Rapid (large) = 230 mm

Triple ring (wok) = 270 mm

2. For Universal LPG hotplates

Auxiliary (small), Semi-Rapid (medium) and Rapid (large) = 195 mm

Triple ring (wok) = 230 mm

The **minimum** utensil (pan) diameters in millimeters (mm) for each burner are:

Auxiliary (small) = 80 mm

and Semi-Rapid (medium) = 140 mm

Rapid (large) and Triple ring (wok) = 195 mm

For best efficiency and to ensure utensil handle does not overheat, place the utensil centrally on the burner and adjust the flame height so all the flame remains under the utensil.

Maintenance & Troubleshooting

Cleaning and maintenance should be carried out with the appliance cold especially when cleaning the enameled parts. Avoid leaving alkaline or acid substances (lemon juice, vinegar etc.) on the surfaces.

BLACK GLASS

The black glass hob of the hotplate must be cleaned regularly (e.g. weekly) to ensure long life expectancy of the hotplate.

Ensure hotplate has cooled. Wash down with warm soapy water and rinse with clean water. Dry with a clean soft cloth. A specialized stainless steel cleaning fluid may be used.

TRIVETS (UTENSIL SUPPORTS)

Enameled parts must only be washed with a sponge and soapy water or with non-abrasive products. Rinse with clean water. Dry with a clean soft cloth.

BURNERS

Remove trivets from hob. Ensure burners are cool. Remove the burners enameled cap (C) and aluminum burner crown (F).

Wash down with warm soapy water and rinse with clean water. Dry with a clean soft cloth.

Use a cotton bud, tooth brush, or some other item to clean out any incrustations or dirt from the four holes marked(H)

Replace burners and ensure they are correctly repositioned over the igniter (S) and thermocouple (T). The igniter (S) must be clean for trouble free sparking. Test burner ignition and burner flame for correct operation.

The Triple Ring (Wok) burner (diagrams below) does not fit over the igniter or thermocouple but must be placed on its supports. If burner is placed correctly it will not rotate on its supports.

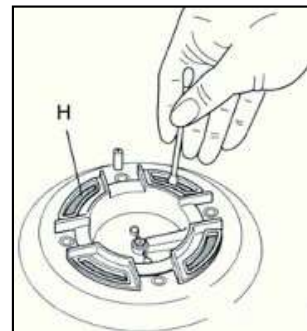
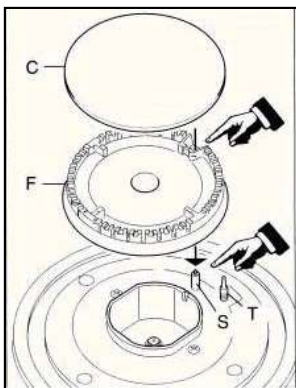

(b) removal of components for service—

(ii) pilot and flame safeguard;

(vii) hotplate top;

(c) parts replacement—

(iv) electronic ignition;

(iii) ignition system;

(ix) thermocouple;

(d) adjustments—

(iv) ignition (spark gap);

(v) gas control;

TROUBLESHOOTING

Servicing of the hotplates must only be done by an authorised service representative (see back of this booklet) and the hotplate must not be modified. Power must be disconnected before any servicing or maintenance is conducted.

DO NOT MODIFY THIS APPLIANCE.

It is recommended the hotplate serviced by an authorized person at least every 2 years. This service is not covered by warranty.

Abnormal conditions include:

- Excessively yellow or sooting flame type.
- Flame lifting off the burner ports.
- Flame lighting back into the burner (normally associated with a popping sound).
- Objectionable odour of the flames combustion products.

Should a faulty condition develop in the hotplate that is not described above, refer to the following table first for possible causes and remedies prior to contacting an authorised service representative. Servicing beyond the remedies listed shall only be undertaken by an authorised service representative.

FAULT	POSSIBLE CAUSE	REMEDY
No spark when gas control knob depressed.	No power.	Check plugged in and switched on. Check mains circuit breaker.
	Loose sparker cable.	Call authorised representative.
	Burner not aligned properly.	Remove and re-fit burner.
Burner not lighting when spark ignition working.	Gas supply off.	Check gas supply valve on.
	Burner not aligned properly.	Remove and re-fit burner.
	Burner ports blocked.	Remove, clean and replace burner.
Burner goes out when control knob released.	Flame failure safeguard not activated.	Re-light, allow more time for flame safeguard to activate.
	Flame safeguard has faulty connection or is broken.	Call authorised representative.
Uneven flame pattern or slight flame lifting.	Burner ports blocked.	Remove, clean and replace burner.
At minimum flame setting the flame is too high.	Turn down control setting incorrect.	Call authorised representative.
Small flame on high setting.	Regulator faulty.	Call authorised representative.
	Gas supply pressure low.	Call authorised representative.
	Incorrect injector fitted.	Call authorised representative.
	Blocked injector or gas supply tube.	Call authorised representative.
	Incorrect utensil size.	Refer to operating instructions utensil choice.
Flame too high on high setting.	Regulator faulty.	Call authorised representative.
	Incorrect injector fitted.	Call authorised representative.
	Incorrect pan, cookware or utensil size.	Refer to operating instructions utensil choice.



Worldwide Appliances Pty Limited
A.B.N. 45868077422

Office:

48-50 Moore Street, Leichhardt N.S.W 2040

Post:

Locked Bag 3000, Annandale, N.S.W 2038

P: 1300 694 583

WARRANTY REGISTRATION

Your ongoing satisfaction with your artusi product is important to us. We ask that you complete the enclosed Warranty Registration Card and return it to us so that we have a record of the artusi product purchased by you.

PRIVACY

Worldwide Appliances respects your privacy and is committed to handling your personal information in accordance with the National Privacy Principles and the Privacy Act 1988 (Cth). A copy of the Worldwide Appliances Privacy Policy is available at www.artusi.com.au. Worldwide Appliances will not disclose any personal information set out in the Warranty Registration Card ("Personal Information") without your consent unless required by:

1. law;
2. any Worldwide Appliances related company;
3. any service provider which provide services to artusi or assist artusi in providing services (including repair and warranty services) to customers. Our purpose in collecting the Personal Information is

to keep a record of the artusi product purchased by you, in order to provide a better warranty service to you in the unlikely event that there is a problem with your artusi product. Worldwide Appliances may contact you at any one or more of the address, email address or telephone numbers set out in the Warranty Registration Card. Please contact artusi on 1300 694 583 should you not wish to be contacted by Worldwide Appliances.

WARRANTY

1. Warranty

Worldwide Appliances warrants that each artusi product will remain, for a period of either 12 months or 24 months of warranty. All Warranties are valid from the original date of purchase, And warranty claims must be accompanied by the proof of purchase.

24 months warranty products:

All Built-in Appliances – Limited to Ovens, Gas, Induction and Electric Cooktops, and All Rangehoods

Freestanding Cookers - Gas and Electric Models (900mm Width)

Dishwashers - Freestanding, Fully Integrated, Semi Integrated and built-in

12 months warranty products:

Freestanding Cookers - Gas and Electric Models in 50cm, 54cm and 60cm Widths

Portable Appliances* – Benchtop Models and Portable Gas Models

2. What is not Covered by the Warranty.

The Warranty does not apply if an artusi product is defective by a factor other than a defect arising in the manufacture of the artusi product, including but not limited to:

- (a) damage through misuse (including failure to maintain, service or use with proper care), neglect, accident or ordinary wear and tear (including deterioration of parts and accessories and glass breakage);
- (b) use for purpose for which the artusi product was not sold or designed;
- (c) use or installation which is not in accordance with any specified instructions for use or installation;
- (d) use or operation after a defect has occurred or been discovered;
- (e) damage through freight, transportation or handling in transit (other than when Worldwide Appliances is responsible);
- (f) damage through exposure to chemicals, dusts, residues, excessive voltage, heat, atmospheric conditions or other forces or environmental factors outside the control of Worldwide Appliances;
- (g) repair, modification or tampering by the purchaser or any person other than Worldwide Appliances, an employee of Worldwide Appliances or an authorised artusi service contractor*;
- (h) use of parts, components or accessories which have not been supplied or specifically approved by artusi.
- (i) damage to surface coatings caused by cleaning or maintenance using products not recommended in the artusi product handbook provided to the purchaser upon purchase of the artusi product;
- (j) damage to the base of an electric oven due to items having been placed on the base of the oven cavity or covering the base, such as aluminium foil (this impedes the transfer of heat from the element to the oven cavity and can result in irreparable damage); or
- (k) damages, dents or other cosmetic imperfections not affecting the performance of the artusi in respect of an artusi product purchased as a "factory second" or from display

The Warranty does not extend to light globes used in artusi products.

3. Domestic Use

Each artusi product is made for domestic use. This Warranty may not extend to artusi products used for commercial purposes.

Continued over...

4. Time for Claim under the Warranty

You must make any claim under this Warranty within twenty eight (28) days after the occurrence of an event which gives rise to a claim pursuant to the Warranty, by booking a service call on the telephone number below.

5. Proof of Purchase

Customers must retain proof of purchase in order to be eligible to make a warranty claim in respect of an artusi product.

6. Claiming under the Warranty

Customers will bear the cost of claiming under this Warranty unless Worldwide Appliances determines the expenses are reasonable, in which case the customer must claim those expenses by providing written evidence of each expense to Worldwide Appliances at the address on the Warranty Registration Card.

7. Statutory Rights

(a) These terms and conditions do not affect your statutory rights.

(b) The limitations on the Warranty set out in this document do not exclude or limit the application of the consumer guarantees set out in the Act or any other equivalent or corresponding legislation in the relevant jurisdiction where to do so would:

(i) contravene the law of the relevant jurisdiction; or

(ii) cause any part of the Warranty to be void.

(c) Worldwide Appliances excludes indirect or consequential loss of any kind (including, without limitation, loss of use of the artusi product) and (other than expressly provided for in these terms and conditions) subject to all terms, conditions and warranties implied by custom, the general law, the Act or other statute.

(d) The liability of Worldwide Appliances to you

for a breach of any express or non-excludable implied term, condition or warranty is limited at the option of Worldwide Appliances to:

(i) replacing or repairing the defective part of the artusi product;

(ii) paying the cost of replacing or repairing the defective part of the artusi product;

(iii) replacing the artusi product; or

(iv) paying the cost of replacing the artusi product.

(e) Our goods come with guarantees that cannot be excluded under the Australian Consumer Law. You are entitled to a replacement or refund for a major failure and for compensation for any other reasonably foreseeable loss or damage. You are also entitled to have the goods repaired or replaced if the goods fail to be of acceptable quality and the failure does not amount to a major failure.

8. Defects

Any part of an artusi product deemed to be defective and replaced by Worldwide Appliances is the property of Worldwide Appliances. Worldwide Appliances reserves the right to inspect and test artusi products in order to determine the extent of any defect and the validity of a claim under the Warranty.

*To locate your closest artusi authorised service agent please contact us on 1300 652 100 or visit www.artusi.com.au

ALL SERVICE CALLS MUST BE BOOKED THROUGH AN AUTHORISED DEALER OR WARRANTY DEPARTMENT ON 1300 652 100 OR stokesaps.com.au/artusi-service

01032014



Warranty Card tear off

WARRANTY REGISTRATION CARD
01052013

Please complete and send to ARTUSI at: REPLY PAID 83617
LEICHHARDT NSW 2040

Last Name:		First Name:	
Address:			
State:	Postcode:	Email:	
Home Phone:		Mobile:	
Purchase Date: / /		(Please attach proof of purchase to validate warranty)	

MODEL NUMBER	SERIAL NUMBER <small>(if you cannot locate the serial number please call ARTUSI on 1300 694 583)</small>
1	
2	
3	
4	

01032014





DISCLAIMER

Worldwide Appliances PTY LTD, trading as ARTUSI, is continually seeking ways to improve the design specifications, aesthetics and production techniques of its products. As a result alterations to our products and designs take place continually. Whilst every effort is made to produce information and literature that is up to date, this brochure should not be regarded as an infallible guide to the current specifications, nor does it constitute an offer for the sale of any particular product. Product dimensions indicated in our literature is indicative only. Actual product only should be used to define dimension cutouts. Distributors, and retailers are not agents of ARTUSI and are not authorised to bind ARTUSI by any express or implied undertaking or representation.

ARTUSI OFFICES ARE OPEN DAILY FROM 9AM-5PM AND SATURDAYS 10AM-4PM

NSW & ACT (HEAD OFFICE)
48-50 MOORE STREET
LEICHHARDT
F 02 8569 4699

VIC, TAS & SA
1211 TOORAK ROAD
CAMBERWELL
F 03 9809 2155

QLD
1/42 CAVENDISH ROAD
COORPAROO
F 07 3397 0850

WA & NT
UNIT 10/55 HOWE STREET
OSBORNE PARK
F 08 9201 9188

NZ
PO BOX 11160
SOCKBURN CHRISTCHURCH
F 03 344 5906

P: 1300 649 583

ARTUSI.COM.AU

