

TimeSmart
Tips Inside!

Use & Care

Microwave Hood Combination

A Note to You.....2

Microwave Oven
Safety3-5

Installation
Instructions6

Getting to Know Your
Microwave Oven9

Using Your
Microwave Oven23

Caring for Your
Microwave Oven36

Cooking Guide.....39

Questions and
Answers41

Troubleshooting.....42

Requesting
Assistance or
Service44

Index47

Warranty.....48

In the U.S.A. for assistance or service,
call the Consumer Assistance Center:

1-800-253-1301

In Canada for assistance or service,
see page 45.

MODEL GH7145XF
PART NO. 8169421 4619-652-55304



www.whirlpool.com

4-99

A NOTE TO YOU

Thank you for buying a WHIRLPOOL* appliance.

The Whirlpool Brand is committed to designing quality products that consistently perform for you to make your life easier. To ensure that you enjoy years of trouble-free operation, we developed this Use and Care Guide. It is full of valuable information about how to operate and maintain your appliance properly and safely. Please read it carefully.

Also, complete and mail the **Product Registration Card** provided with your appliance. The card helps us notify you about any new information on your appliance.

Please record your model's information.

Whenever you call to request service for your appliance, you need to know your complete model number and serial number. You can find this information on the model and serial number label/plate (see "Microwave oven features" in the "Getting to Know" section). Also, record the other information shown in the next column.

Model Number _____
Serial Number _____
Purchase Date _____
Dealer Name _____
Dealer Address _____
Dealer Phone _____

Keep this book and the sales slip together in a safe place for future reference.

Our Consumer Assistance Center number is toll free.

1-800-253-1301

To find detailed product information, the location of the nearest Whirlpool dealer or authorized servicer, to purchase an accessory item, or register your appliance on-line, please visit our Web site at www.whirlpool.com

In Canada, for assistance or service, see the "Requesting Assistance or Service" section.

In Canada, visit our Web site at www.whirlpoolappliances.com/canada

MICROWAVE OVEN SAFETY

Your safety and the safety of others is very important.

We have provided many important safety messages in this manual and on your appliance. Always read and obey all safety messages.



This is the safety alert symbol.

This symbol alerts you to hazards that can kill or hurt you and others.

All safety messages will be preceded by the safety alert symbol and the word "DANGER" or "WARNING." These words mean:

⚠ DANGER

You will be killed or seriously injured if you don't follow instructions.

⚠ WARNING

You can be killed or seriously injured if you don't follow instructions.

All safety messages will identify the hazard, tell you how to reduce the chance of injury, and tell you what can happen if the instructions are not followed.

IMPORTANT SAFETY INSTRUCTIONS

When using electrical appliances basic safety precautions should be followed, including the following:

WARNING: To reduce the risk of burns, electric shock, fire, injury to persons or exposure to excessive microwave energy:

- Read all instructions before using the microwave oven.
- Read and follow the specific "PRECAUTIONS TO AVOID POSSIBLE EXPOSURE TO EXCESSIVE MICROWAVE ENERGY" found in this section.
- The microwave oven must be grounded. Connect only to properly grounded outlet. See "GROUNDING INSTRUCTIONS" found at the end of this section.
- Install or locate the microwave oven only in accordance with the provided installation instructions.
- Some products such as whole eggs and sealed containers – for example, closed glass jars – may explode and should not be heated in the microwave oven.
- Use the microwave oven only for its intended use as described in this manual. Do not use corrosive chemicals or vapors in the microwave oven. This type of oven is specifically designed to heat, cook, or dry food. It is not designed for industrial or laboratory use.
- As with any appliance, close supervision is necessary when used by children.
- Do not operate the microwave oven if it has a damaged cord or plug, if it is not working properly, or if it has been damaged or dropped.
- The microwave oven should be serviced only by qualified service personnel. Call an authorized service company for examination, repair or adjustment.
- Do not cover or block any openings on the microwave oven.
- Do not store the microwave oven outdoors. Do not use the microwave oven near water – for example, near a kitchen sink, in a wet basement, or near a swimming pool, and the like.
- Do not immerse cord or plug in water.
- Keep cord away from heated surfaces.
- Do not let cord hang over edge of table or counter.
- See door surface cleaning instructions in the "Caring for Your Microwave Oven" section.
- Do not mount over a sink.
- Do not store anything directly on top of the microwave oven when the microwave oven is in operation.

– SAVE THESE INSTRUCTIONS –

continued on next page

IMPORTANT SAFETY INSTRUCTIONS

- To reduce the risk of fire in the oven cavity:
 - Do not overcook food: Carefully attend the microwave oven if paper, plastic, or other combustible materials are placed inside the oven to facilitate cooking.
 - Remove wire twist-ties from paper or plastic bags before placing bag in oven.
 - If materials inside the oven should ignite, keep oven door closed, turn oven off, and disconnect the power cord, or shut off power at the fuse or circuit breaker panel.
 - Do not use the cavity for storage purposes. Do not leave paper products, cooking utensils, or food in the cavity when not in use.
- Suitable for use above both gas and electric cooking equipment.
- Intended to be used above ranges with maximum width of 36 inches.
- Clean Ventilating Hoods Frequently – Grease should not be allowed to accumulate on hood or filter.
- When flaming foods under the hood, turn the fan **on**
- Use care when cleaning the vent-hood filter. Corrosive cleaning agents, such as lye-based oven cleaners, may damage the filter.

– SAVE THESE INSTRUCTIONS –

PRECAUTIONS TO AVOID POSSIBLE EXPOSURE TO EXCESSIVE MICROWAVE ENERGY

- (a)** Do not attempt to operate this oven with the door open since open-door operation can result in harmful exposure to microwave energy. It is important not to defeat or tamper with the safety interlocks.
- (b)** Do not place any object between the oven front face and the door or allow soil or cleaner residue to accumulate on sealing surfaces.
- (c)** Do not operate the oven if it is damaged. It is particularly important that the oven door close properly and that there is no damage to the:
 - (1) door (bent),
 - (2) hinges and latches (broken or loosened),
 - (3) door seals and sealing surfaces.
- (d)** The oven should not be adjusted or repaired by anyone except properly qualified service personnel.

ELECTRICAL REQUIREMENTS

Observe all governing codes and ordinances. A 120 Volt, 60 Hz, AC only, 15 or 20 amp fused electrical supply is required. (A time-delay fuse is recommended.) It is recommended that a separate circuit serving only this appliance be provided.

⚠ WARNING



Electrical Shock Hazard

Plug into a grounded 3 prong outlet.
Do not remove ground prong.
Do not use an adapter.
Do not use an extension cord.
Failure to follow these instructions can result in death, fire, or electrical shock.

GROUNDING INSTRUCTIONS

For all cord connected appliances:

The microwave oven must be grounded. In the event of an electrical short circuit, grounding reduces the risk of electric shock by providing an escape wire for the electric current. The microwave oven is equipped with a cord having a grounding wire with a grounding plug. The plug must be plugged into an outlet that is properly installed and grounded.

WARNING: Improper use of the grounding can result in a risk of electric shock.

Consult a qualified electrician or serviceman if the grounding instructions are not completely understood, or if doubt exists as to whether the microwave oven is properly grounded.

Do not use an extension cord. If the power supply cord is too short, have a qualified electrician or serviceman install an outlet near the microwave oven.

For a permanently connected appliance:
 This microwave oven must be connected to a grounded, metallic, permanent wiring system, or an equipment grounding conductor should be run with the circuit conductors and connected to the equipment grounding terminal or lead on the microwave oven.

INSTALLATION INSTRUCTIONS

SPACE REQUIREMENTS

NOTE: There must be at least one wall stud within cabinet opening.

Check the opening where the microwave oven hood will be installed. The location must provide:

- 2 inch x 4 inch (5.1 x 10.2 cm) wood studding and 3/8 inch (.95 cm) thickness drywall or plaster lath
- Support for microwave oven hood weight of 150 pounds (68 kg) plus the weight of items placed in the oven or upper cabinet
- 30 inch (76.2 cm) wide minimum opening
- 13 1/2 inch (34.3cm) clearance between the bottom of microwave oven hood and the cooktop
- Protection from draft areas, such as windows, doors, and strong heating vents
- Grounded electrical outlet (see "Electrical requirements" in the "Microwave Oven Safety" section)

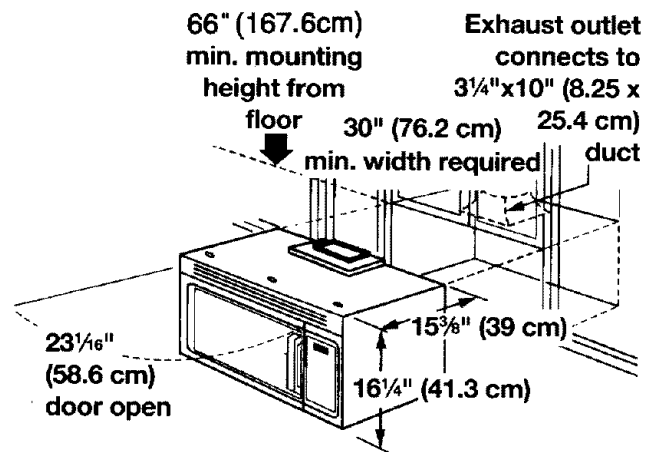

Shipped ready for ventless (recirculating) operation, converts to top or rear discharge.

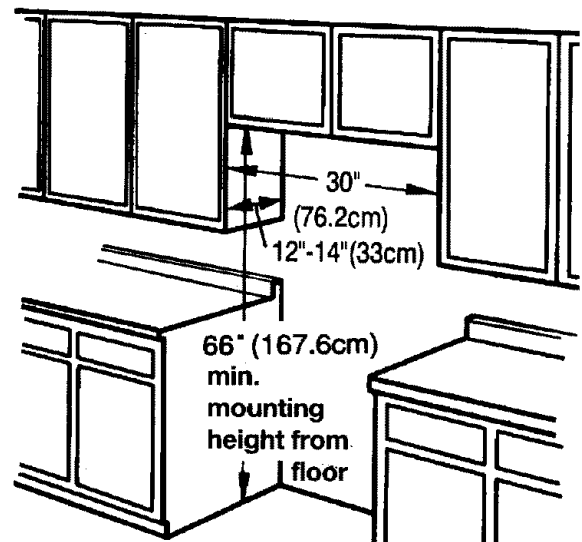

CRITICAL DIMENSIONS	
A	30" (76.2cm) min. from cooking surface (or countertop) below microwave oven to top of wall mounting bracket
B	13 1/2" (34.3cm) min. to cooking surface (or countertop) below microwave oven

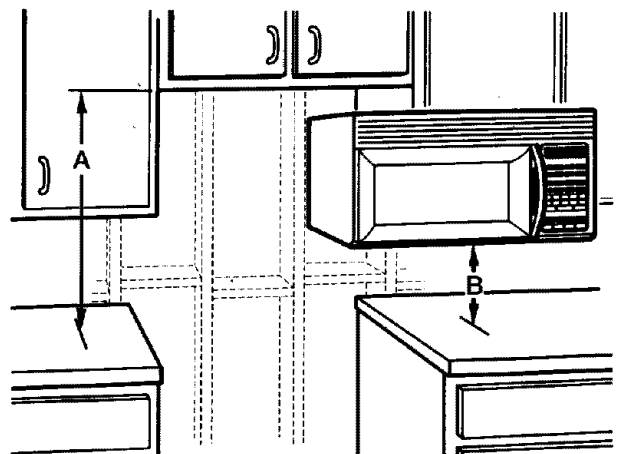

REMOVING AND REPLACING THE MICROWAVE OVEN

⚠ WARNING

Excessive Weight Hazard

Use two or more people to move and install microwave oven.

Failure to do so can result in back or other injury.

If you need to remove your Microwave Hood Combination for any reason, follow these simple steps:

To remove:

1. Unplug microwave oven or disconnect power.
2. Remove filters and vent grille.

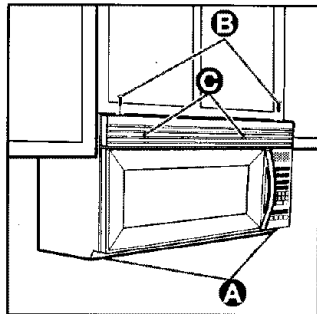

- If filters **A** are installed, push in at the tab and slide filter to the outside edge to remove.
- Remove the two screws **B** from the top of the microwave oven cabinet (the screws located closest to the front corners). Do not remove the screws located towards the center of the cabinet.

- Remove the vent grille **C**. Set the screws and grille aside. (If grille cannot be removed, see pt. 4.)

3. After removing all oven contents, including the turntable and support, tape the door in the closed position. Then remove the two bolts **D** securing the microwave oven to the upper cabinet.

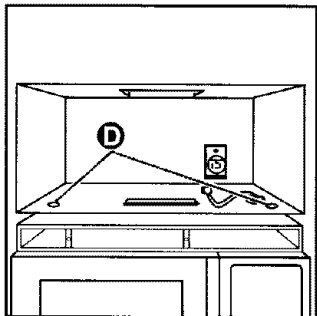

4. Hold microwave hood combination in place with one hand. Pull hook **E** to release microwave hood from mounting plate. If grille cannot be removed (per instructions in pt. 2.), insert a thin looped wire or similar tool through an opening in grille to pull hook.

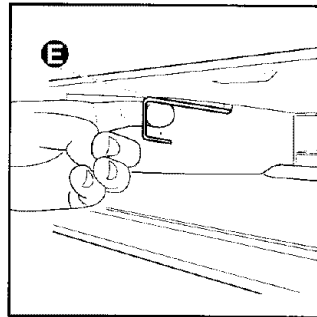

5. Grasp the microwave oven. Rotate the microwave oven downward. (Be careful that door does not swing open.) Lift off the support tabs **F** at the bottom of the mounting plate. Set the microwave oven aside on a protected surface.

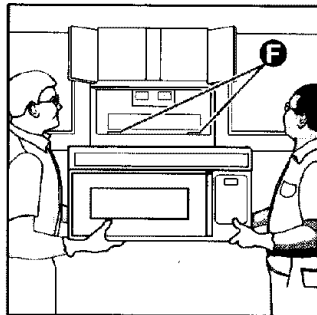
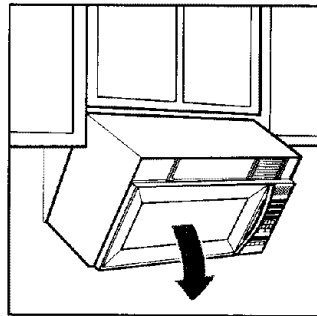

continued on next page

REMOVING AND REPLACING THE MICROWAVE OVEN (CONT.)

To replace:

1. Carefully lift microwave oven and hang it on the support tabs at the bottom of the mounting plate.
2. Rotate the front of the microwave oven cabinet downward. Thread the power supply cord through the power supply cord hole in the bottom of the upper cabinet.
3. Rotate the microwave oven towards the cabinet. Push the microwave oven against the mounting plate until locking latch snaps into the cabinet.
4. Replace the two bolts securing the microwave oven to the upper cabinet.
5. Untape the door and replace the turntable and support.
6. Replace the vent grille.
7. Replace the two screws in the top of microwave oven cabinet (the screws located closest to front corners).
8. If filters were installed, replace them (see "Installing and caring for the filters" in the "Caring for Your Microwave Oven" section, if needed).
9. Plug in microwave oven or reconnect power.

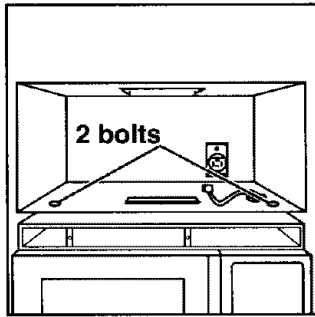

GETTING TO KNOW YOUR MICROWAVE OVEN

This section discusses the concepts behind microwave cooking. It also shows you the basics you need to know to operate your microwave oven. Please read this information before you use your microwave oven.

HOW YOUR MICROWAVE OVEN WORKS

Microwave ovens are safe. Microwave energy is not hot. It causes food to make its own heat, and it's this heat that cooks the food.

Microwaves are like TV waves or light waves. You cannot see them, but you can see what they do.

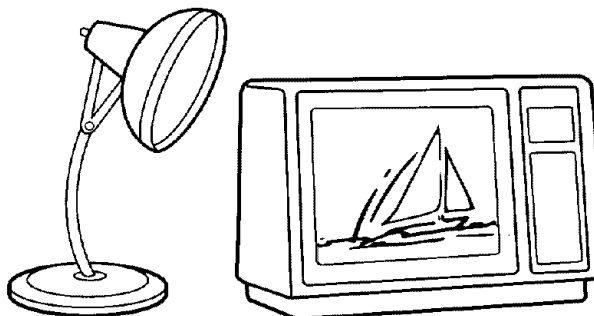

A magnetron in the microwave oven produces microwaves. The microwaves move into the oven where they contact food as it turns on the turntable.

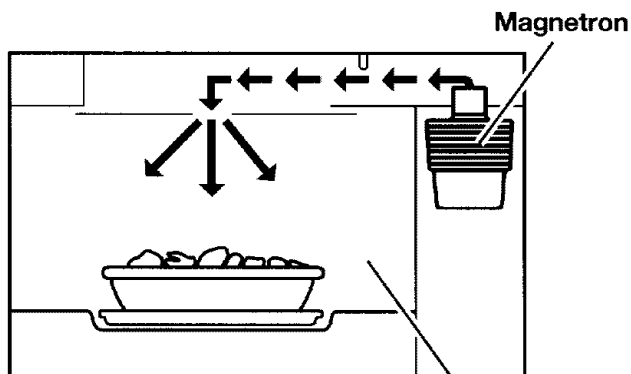

Oven cavity

The glass turntable of your microwave oven lets microwaves pass through. Then they bounce off a metal floor, back through the glass turntable, and are absorbed by the food.

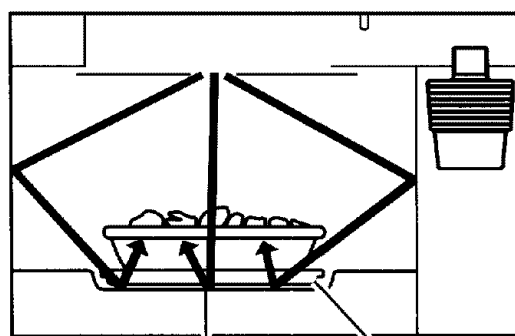

Metal floor Glass turntable

continued on next page

HOW YOUR MICROWAVE OVEN WORKS (CONT.)

Microwaves pass through most glass, paper, and plastics without heating them so food absorbs the energy. Microwaves bounce off metal containers so food does not absorb the energy.

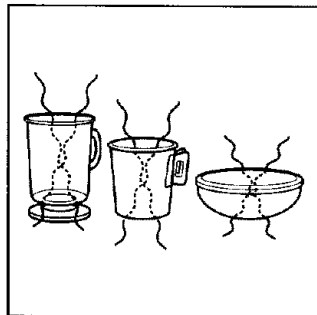

Microwaves may not reach the center of a roast.

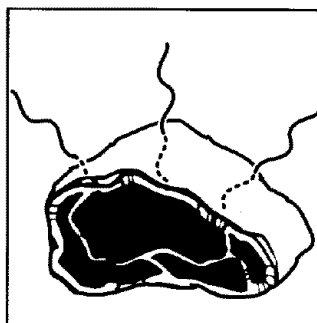

The heat spreads to the center from the outer, cooked areas just as in regular oven cooking. This is one of the reasons for letting some foods (for example, roasts or baked potatoes) stand for a while after cooking, or for stirring

some foods during the cooking time.

The microwaves disturb water molecules in the food. As the molecules bounce around bumping into each other, heat is made, like rubbing your hands together. This is the heat that does the cooking.

TimeSmart TIP

For the best cooking results

- Always cook food for the shortest cooking time recommended. Check to see how the food is cooking. If needed, touch ADD MINUTE while the oven is operating or after the cooking cycle is over (see the "Using ADD MINUTE" section).
- To help make sure the food is evenly cooked, stir, turn over, or rearrange the food about halfway through the cooking time.
- If you do not have a cover for a dish, use wax paper, or microwave-approved paper towels or plastic wrap. Remember to turn back a corner of the plastic wrap $\frac{1}{4}$ to $\frac{1}{2}$ inches (6 mm to 1.2 cm) to vent steam during heating or cooking.

NOTE: Do not deep fry in the oven. Microwavable cookware is not suitable and it is difficult to maintain appropriate deep-frying temperatures.

RADIO INTERFERENCE

Using your microwave oven may cause interference to your radio, TV, or similar equipment. When there is interference, you can reduce it or remove it by:

- Cleaning the door and sealing surfaces of the oven.
- Adjusting the receiving antenna of the radio or television.
- Moving the radio or TV away from the microwave oven.
- Plugging the microwave oven into a different outlet so that the microwave oven and radio or TV are on different branch circuits.

TESTING YOUR MICROWAVE OVEN

To test the oven put about 1 cup (250 mL) of cold water in a glass container in the oven. Close the door and make sure it latches. Follow the directions in "Cooking at high cook power" in the "Using Your Microwave Oven" section to set the oven to cook for 2 minutes. When the time is up, the water should be heated.



TESTING YOUR DINNERWARE OR COOKWARE

Test dinnerware or cookware before using.

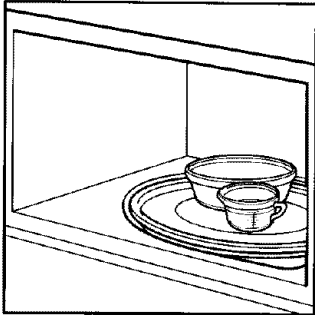

To test a dish for safe use, put it into the oven with a cup of water beside it. Cook at 100% cook power for 1 minute. **If the dish gets hot and water stays cool, do not use it.**

Some dishes (melamine, some ceramic dinnerware, etc.) absorb microwave energy, becoming too hot to handle and slowing cooking times. Cooking in metal containers not designed for microwave use could damage the oven, as could containers with hidden metal (twist-ties, foil lining, staples, metallic glaze or trim).

OPERATING SAFETY PRECAUTIONS

Never cook or reheat a whole egg inside the shell.

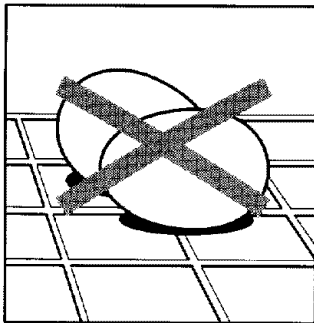

Steam buildup in whole eggs may cause them to burst and burn you, and possibly damage the oven. **Slice** hard-boiled eggs before heating. In rare cases, poached eggs have been known to explode. **Cover** poached eggs and

allow a standing time of 1 minute before cutting into them.

For best results, stir any liquid several times during heating or reheating.

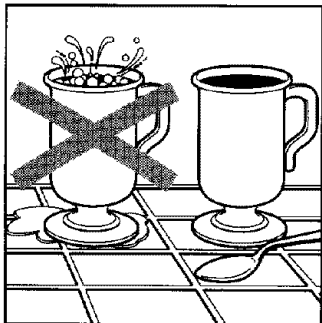

Liquids heated in certain containers (especially containers shaped like cylinders) may become overheated. The liquid may splash out with a loud noise during or after heating or when adding ingredients

(coffee granules, tea bags, etc.). This can harm the oven and possibly injure someone.

Never lean on the door or allow a child to swing on it

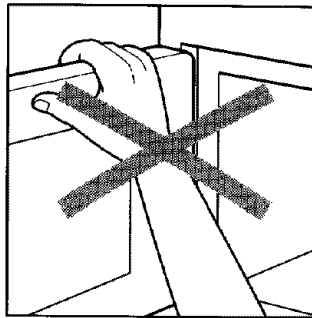

when the door is open. Injury could result.

Use hot pads.

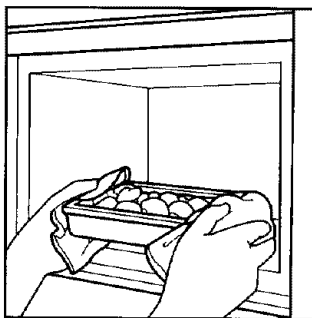

Microwave energy does not heat containers, but the heat from the food can make the container hot.

continued on next page

OPERATING SAFETY PRECAUTIONS (CONT.)

Do not overcook potatoes. Fire could result. At the end of the recommended cooking time, potatoes should be slightly firm because they will continue cooking during standing time. **After microwaving, let** potatoes stand for 5 minutes. They will finish cooking while standing.

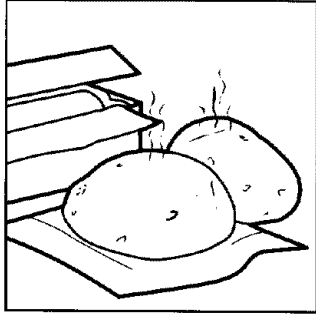

Do not try to melt paraffin wax in the oven. Paraffin wax will not melt in a microwave oven because it allows microwaves to pass through it.

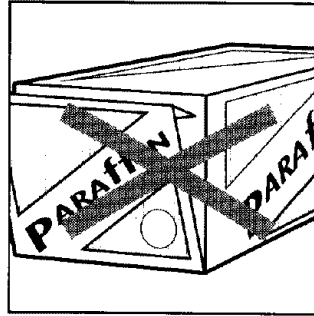

Do not start a microwave oven when it is empty. Product life may be shortened. If you practice programming the oven, **put** a container of water in the oven or use the Demo/learning feature (see "Using the demo/learning feature" later in this section).

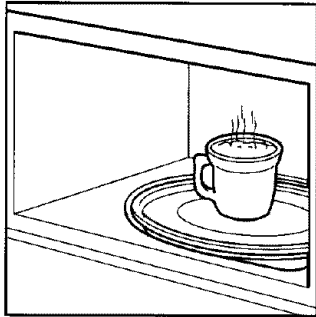

Do not operate the microwave oven unless the glass turntable is securely in place and can rotate freely on the support rollers. The turntable can rotate in either direction. **Make sure** the rollers are completely inside the center circle of the turntable; this will let the turntable rotate properly.

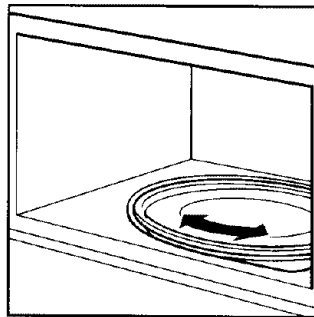

It is normal for the oven door to look wavy after the oven has been running for a while.

Make sure the turntable is correct-side up in the oven. **Carefully place** the cookware on your turntable to avoid possibly breaking it.

Do not use newspaper or other printed paper in the oven. Fire could result. **Do not** dry flowers, fruit, herbs, wood, paper, gourds, or clothes in the oven. Fire could result.

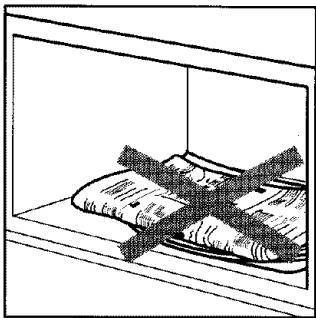

Handle your turntable with care when removing it from the oven to avoid possibly breaking it. If your turntable cracks or breaks, contact your dealer for a replacement.

When you use a browning dish, the browning dish bottom must be at least $\frac{3}{16}$ inch (5 mm) above the turntable. Follow the directions supplied with the browning dish.

ELECTRICAL CONNECTION

If your electric power line or outlet voltage is less than 110 volts, cooking times may be longer. Have a qualified electrician check your electrical system.

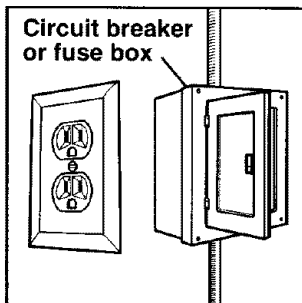

MICROWAVE OVEN FEATURES

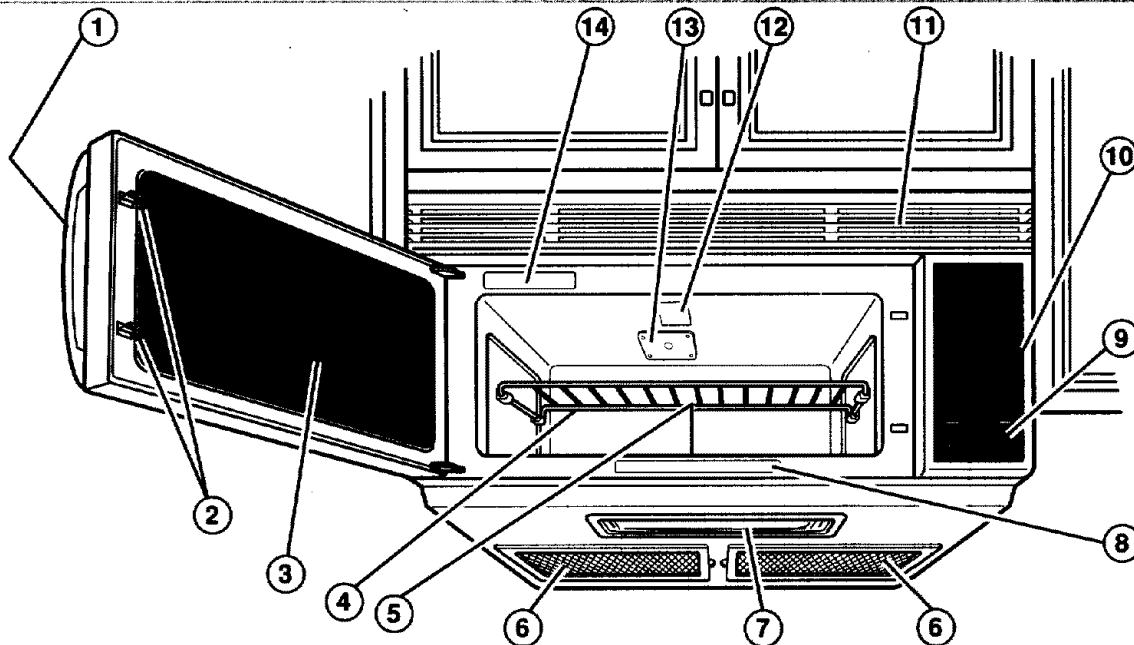

Your microwave oven is designed to make your cooking experience as enjoyable and productive as possible. To help get you up and running quickly, the following is a list of the oven's basic features:

- 1. Door Handle.** Pull to open door.
- 2. Door Safety Lock System.** The oven will not operate unless the door is securely closed.
- 3. Window with Metal Shield.** Shield prevents microwaves from escaping. It is designed as a screen to allow you to view food as it cooks.
- 4. Cooking Rack.** Use for extra space when cooking in more than one container at the same time. See page 18 for more information.
- 5. Glass Turntable (PN 4393751) (not shown).** Included in oven cavity – see below for installation instructions. This turntable turns food as it cooks for more even cooking. It must be in the oven during operation for best cooking results. The turntable is sunken into the cavity floor to give you more cooking space and better cooking results. See pages 9, 12, 36, 41, and 43 for more details.

- 6. Charcoal and Grease Filters.** Included in oven cavity. See page 37 for installation instructions and cleaning information.
- 7. Cooktop/Countertop Light.** Turn on to light your cooktop or countertop or turn on as a night light. See page 19 for more information.
- 8. Cooking Guide Label.** Use as a quick reference for Quick Cook, Quick Reheat, Quick Defrost, and Sensor Cook settings.
- 9. Exhaust Fan and Cooktop Light Switches.** See page 19 for more information.
- 10. Control Panel.** Touch the pads on this panel to perform all functions. See pages 14-17 for more information.
- 11. Vent Grille.**
- 12. Oven Cavity Light.**
- 13. Microwave Inlet Cover.**
- 14. Model and Serial Number Plate.** See page 2 for more information.

To install turntable and support:

- Fit the hub (PN 4393754) onto the shaft.
 - Place the support (PN 4393752) on the cavity bottom.
 - Place the turntable on the hub. Make sure the raised, curved lines in the center of the turntable bottom are between the three "spokes" of the hub.

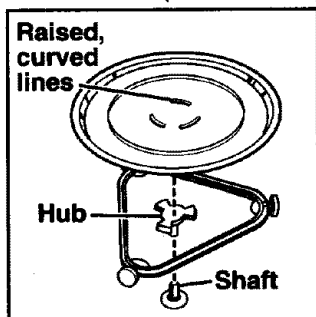

- The rollers (PN 4393753) on the support should fit inside the ridge on the bottom of the turntable.
- The turntable turns both clockwise and counter-clockwise. This is normal.

CONTROL PANEL FEATURES

1. **Display.** This display includes a clock and indicators to tell you the time of day, cooking time settings, and cooking functions you chose.
2. **POPCORN.** Touch this pad to pop one of 3 bag sizes of popcorn, without entering a cook power or time. The oven's sensor will tell the oven how long to cook depending on the amount of humidity it detects from the popcorn. See page 34 for more information.
3. **BAKED POTATO.** Touch this pad to bake 1 to 4 potatoes, without entering a cook power or time. The oven's sensor will tell the oven how long to cook depending on the amount of humidity it detects from the potato(es). See page 34 for more information.
4. **FRESH VEGETABLE.** Touch this pad to cook 1 to 4 cups (237 to 946 mL) of a fresh vegetable, without entering a cook power or time. The oven's sensor will tell the oven how long to cook depending on the amount of humidity it detects from the vegetables. See page 34 for more information.
5. **FROZEN VEGETABLE.** Touch this pad to cook 1 to 4 cups (237 to 946 mL) of a frozen vegetable, without entering a cook power or time. The oven's sensor will tell the oven how long to cook depending on the amount of humidity it detects from the vegetables. See page 34 for more information.
6. **FROZEN ENTREE.** Touch this pad to cook a 10- or 20-ounce (283.5 or 567 g) frozen entree, without entering a cook power or time. The oven's sensor will tell the oven how long to cook depending on the amount of humidity it detects from the frozen entree. See page 34 for more information.
7. **BEVERAGE.** Touch this pad to heat 1 or 2 8-ounce (237 mL) cups of a beverage, without entering a cook power or time. The oven's sensor will tell the oven how long to heat depending on the amount of humidity it detects from the beverage. See page 34 for more information.
8. **DINNER PLATE.** Touch this pad to heat a dinner plate of food, without entering a cook power or time. The oven's sensor will tell the oven how long to heat depending on the amount of humidity it detects from the food. See page 35 for more information.
9. **SOUP.** Touch this pad to heat 1 to 4 cups (237 to 946 mL) of soup, without entering a cook power or time. The oven's sensor will tell the oven how long to heat depending on the amount of humidity it detects from the soup. See page 35 for more information.

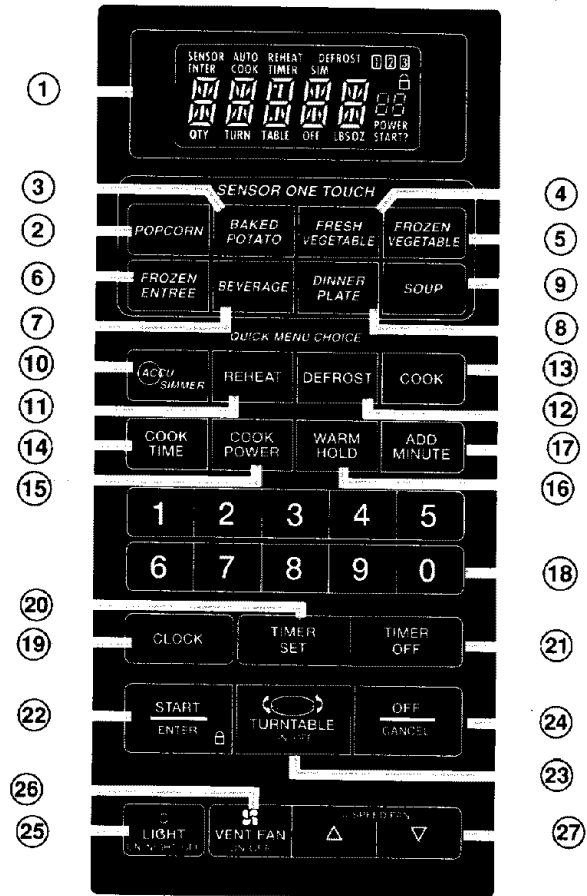

10. **ACCU-SIMMER.** Touch this pad to simmer soups, casseroles, stews, and other liquid foods. See page 33 for more information.
11. **REHEAT.** Touch this pad to reheat microwavable foods without entering times and cook powers. See page 29 for more information.
12. **DEFROST.** Touch this pad to defrost frozen foods without entering times and cook powers. See page 30 for more information.
13. **COOK.** Touch this pad to cook microwavable foods without entering times and cook powers. See page 28 for more information.
14. **COOK TIME.** Touch this pad followed by Number pads to set a cooking time. See pages 23, 24, and 26 for more information.

CONTROL PANEL FEATURES (CONT.)





- 15. COOK POWER.** Touch this pad after the cooking time has been set, followed by a Number pad to set the amount of microwave energy released to cook the food. Also touch this pad to lengthen or shorten a preset cooking time. See pages 22 and 24 for more information.
- 16. WARM HOLD.** Touch this pad to keep hot, cooked foods safely warm in your microwave oven for up to 99 minutes, 99 seconds. WARM HOLD can be used by itself, or it can automatically follow a cooking cycle. See page 35 for more information.
- 17. ADD MINUTE.** Touch this pad to cook for 1 minute, at 100% cook power, or to add an extra minute to your cooking cycle at the set cook power. See page 22 for more information.
- 18. Number pads.** Touch Number pads to enter cooking times, cook powers, quantities, weights, or food categories.
- 19. CLOCK.** Touch this pad to enter the correct time of day. See page 20 for more information.
- 20. TIMER SET.** Touch this pad to set the Minute Timer. See page 21 for more information.
- 21. TIMER OFF.** Touch this pad to cancel the Minute Timer. See page 21 for more information.
- 22. START/ENTER.** Touch this pad to start a function. See page 16 for more information.
- 23. TURNTABLE ON/OFF.** Touch this pad to turn your turntable on and off. See page 17 for more information.
- 24. OFF/CANCEL.** Touch this pad to erase an incorrect command, cancel a program during cooking, or to clear the display. See page 16 for more information.
- 25. LIGHT ON/NIGHT/OFF.** Touch this pad to turn the light or night light on or off. See page 19 for more information.
- 26. VENT FAN ON/OFF.** Touch this pad to turn the fan on or off. See page 19 for more information.
- 27. 4 SPEED FAN.** Touch the “up” pad to increase fan speed and the “down” pad to decrease fan speed. See page 19 for more information.
- NOTES:**
- If you have entered all settings for a function but do not touch START/ENTER in 5 seconds, the START? indicator light will show.
 - For nonsensor functions, if you open the door while the oven is on and then shut the door within 15 minutes, the START? indicator light will show. Touch START/ENTER to continue. If you open the door when sensor cooking, cooking is canceled and you have to start over.
 - If you choose a function but do not press another Command pad within 1 minute, the display returns to the time of day and you have to start over.

continued on next page

CONTROL PANEL FEATURES (CONT.)

Audible signals

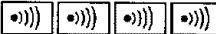
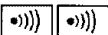
Your microwave oven comes with audible signals that can guide you when setting and using your oven:

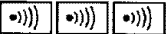
-  A programming tone will sound each time you touch a pad.
-  One long tone signals the end of a Minute Timer countdown.
-  Four tones signal the end of a cooking cycle.
-  Two quick, short tones sound once every minute for the first 15 minutes after an end-of-cooking signal as a reminder if the food has not been removed from the oven.
-  Two quick, short tones will sound while entering and exiting from a hidden feature (for example, Child Lock) or time of day.
-  Three tones sound if you have made an incorrect entry.

To disable the programming tone:

TOUCH



and hold for 5 seconds

To turn the programming tone back on:

TOUCH



and hold for 5 seconds

To disable all audible signals except the end-of-timer and hidden feature signals:

TOUCH



and hold for 5 seconds

To turn signals back on:

TOUCH



and hold for 5 seconds

NOTE: Two tones will sound when audible signals are turned on or off.

Interrupting cooking

You can stop the oven during a cycle by opening the door. The oven stops heating and the fan stops, but the light stays on. To restart cooking, close the door and

TOUCH



If you do not want to continue cooking:

- Close the door and the light goes off.

OR

- **TOUCH**



NOTE: Before setting a function, touch OFF/CANCEL to make sure no other function is on.

CONTROL PANEL FEATURES (CONT.)

Heating more than one plate of food

When heating plates of food with a cook time that you set, you can heat two 10-inch (25.4 cm) plates side by side or one dish larger than the turntable. You can heat 2 more plates on the Cooking Rack for a possible total of 4 plates. For best results, halfway through cooking turn the plates halfway around until the food in the front is in the back. Do the same when heating a larger (9- to 13-inch [23 to 33 cm]) casserole. When heating 4 dinner plates turn as described above and switch the top plates with the bottom plates.

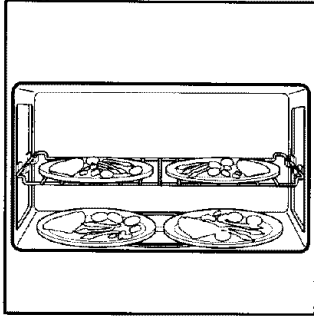

To heat 2 bottom plates together or one larger dish, the turntable should not be turning. You can shut the turntable off by touching TURNTABLE ON/OFF. "TURNTABLE OFF" appears on the display. If you touch TURNTABLE ON/OFF before starting to set the cooking function, your oven will prompt you to enter a cooking time without you needing to touch COOK TIME. Your turntable will be turned back on when cooking is over or when you touch OFF/CANCEL.

NOTE: You cannot turn off the turntable when using an "auto" function.



Using the child lock

The Child Lock locks the control panel so children cannot use the microwave oven when you do not want them to.

To lock the control panel:

TOUCH



and hold for 5 seconds

Two tones will sound and  will appear on the display. When the control panel is locked, 3 tones will sound and LOCK will appear when you touch any pad except for VENT FAN and LIGHT.

To unlock the control panel:

TOUCH



and hold for 5 seconds

Two tones will sound and  will be cleared from the display.

Using the demo/learning feature

You can set your microwave oven to display your commands as you enter them without turning the magnetron on. This feature helps you learn to use your oven without actually cooking food.

To set the demo/learning feature:

TOUCH



and hold for 5 seconds

Two tones will sound and a small "d" will appear on the display.

To cancel the demo/learning feature:

TOUCH



and hold for 5 seconds

Two tones will sound and the small "d" will disappear from the display.

USING THE COOKING RACK

The Cooking Rack gives you extra space when cooking in more than one container at the same time.

If you need a replacement rack, you can order one from your authorized service company, or by calling the Consumer Assistance Center at **1-800-253-1301** (in U.S.A.) or **1-800-461-5681** (in Canada). When calling, follow the instructions and telephone prompts you hear. Make sure to have your model number when ordering.

Inserting the rack

Insert the rack securely into the rack supports on the side walls of the oven.

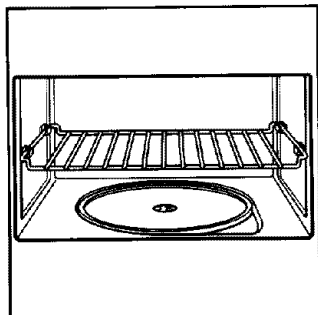

NOTES:

- Use oven mitts to remove items from microwave oven.
- Do not store the metal rack in the oven. Arcing and damage to the oven could result if someone accidentally starts the oven.
- Do not operate the oven with the metal rack stored on the floor of the oven. Damage to the interior finish will result.
- Use rack only in the microwave oven.
- Do not use rack with browning dish.
- Do not let food container on rack touch the top or sides of the oven.
- Do not cook foods directly on rack. Put them in microwave-safe containers first.
- Do not place a metal cooking container on rack.
- Only use the Cooking Rack when cooking at more than one level.

USING THE EXHAUST FAN

The pads on the bottom right of the control panel control the 4-speed exhaust fan.

1. Turn on the fan and choose fan speed.

Touch the “up” pad to increase fan speed.
Touch the “down” pad to decrease fan speed.
The display will show “FAN” and a number from 1 to 4 to indicate fan speed.

NOTE: If the temperature from the range or cooktop below the oven gets too hot, the exhaust fan in the vent hood will automatically turn on at the HIGH setting to protect the oven. **It may stay on up to an hour to cool the oven. When this occurs, the VENT FAN pad will not turn the fan off.**

NOTES:

- Two seconds after the last time you touch VENT FAN, the display returns to the previous display.
- The first time you turn on the fan after connecting the microwave oven to power, the fan will start at speed 1. The next time the fan is turned on, it will start at the last speed used.

TOUCH



2. Turn off fan when desired.

TOUCH



USING THE COOKTOP/COUNTERTOP LIGHT

The pad on the bottom left of the control panel controls the cooktop/countertop light.

1. Turn on light.

TOUCH



(once for regular light, twice for night light)

2. Turn off light when desired.

TOUCH



(1 or 2 more times, depending on light setting)

SETTING THE CLOCK

When your microwave oven is first plugged in, or after a power failure, the display will flash “:”. If a time of day is not set, “:” will show until you touch any pad.

NOTES:

- If you touch in an invalid time and touch CLOCK, 3 tones will sound. Enter the correct time.
- If you touch OFF/CANCEL while setting the clock, the display will show the last time of day set.
- To turn off the clock touch CLOCK, Number pad 0, and CLOCK again, the set time will disappear and “:” will show on the display.

1. Touch CLOCK.

TOUCH



YOU SEE



2. Enter the time of day.
Example for 12:00:

TOUCH



YOU SEE



3. Complete your entry.

TOUCH

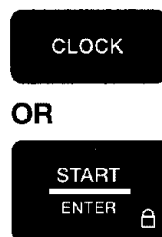

YOU SEE



USING THE MINUTE TIMER

You can use your microwave oven as a kitchen timer. Use the Minute Timer for timing up to 99 minutes, 99 seconds.

NOTE: The oven can operate while the Minute Timer is in use. To see the Minute Timer while the oven is cooking, touch **TIMER SET**.

1. Touch **TIMER SET**.

TOUCH



YOU SEE



2. Enter the time to be counted down.

Example for 1 minute, 30 seconds:

NOTE: If you enter more than 4 digits, the first 4 digits will disappear and the following digit(s) will appear on the right side as you enter them.

TOUCH



YOU SEE



3. Start the countdown.

NOTE: If you do not do this step within 5 seconds of doing Step 2, "START?" will appear. You then have 1 minute to touch **START/ENTER** or **TIMER SET** before the display returns to the time of day.

TOUCH



OR



YOU SEE



At the end of the countdown:

YOU SEE



(one long tone will sound)

To cancel the minute timer:

During the countdown:

TOUCH



OR



YOU SEE



(time of day)

USING ADD MINUTE

ADD MINUTE lets you cook food for 1 minute at 100% cook power or add an extra minute to your cooking time cycle. You can also use it to extend cooking time cycles in multiples of 1 minute, up to 99 minutes.

NOTES:

- To extend cooking time cycles in multiples of 1 minute, touch ADD MINUTE repeatedly during cooking.
- After closing the door, you can enter ADD MINUTE without having to touch START/ENTER.
- If you touch ADD MINUTE during cooking, the oven will cook at the currently selected cook power. If you touch ADD MINUTE after cooking is over, the oven will cook at 100% cook power. You can also change the cook power after you touch ADD MINUTE by touching COOK POWER, Number pads for the new cook power, and START/ENTER.
- You can use ADD MINUTE only for the cooking time function.

1. Make sure the food is in the oven.

2. Touch ADD MINUTE.

Example for cooking for 1 minute:

TOUCH



YOU SEE



CHANGING PRESET COOKING TIMES

If a preset cooking time is too long or too short, you can lengthen or shorten the cooking time after choosing QUICK COOK, QUICK REHEAT, QUICK DEFROST, or Sensor One Touch (except for the POPCORN setting). For a Quick function, you can

only change cooking times after entering a food quantity, but before cooking starts. For Sensor One Touch, you can only change cooking times within 20 seconds after choosing the food type.

For example, in QUICK REHEAT, after choosing the type of food and entering the quantity:

To lengthen cooking time:

TOUCH



once

YOU SEE



(example for quick reheat)

To shorten cooking time:

TOUCH



twice

YOU SEE



To reset to the original cooking time:

TOUCH



three times

YOU SEE



USING YOUR MICROWAVE OVEN

This section gives you instructions for operating each function. Please read these instructions carefully.

COOKING AT HIGH COOK POWER

1. Put your food in the oven and close the door.

2. Touch COOK TIME.

TOUCH

COOK
TIME

YOU SEE

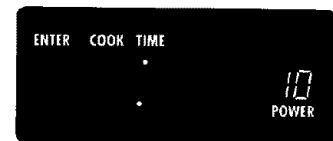

3. Enter the cooking time.

Example for 1 minute, 30 seconds:

TOUCH

1

3

0

YOU SEE



4. Start the oven.

TOUCH

START
ENTER



YOU SEE



At the end of the cooking time:

YOU SEE

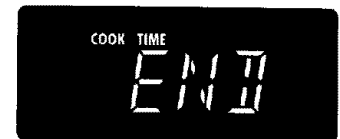

(four tones will sound)

Changing instructions

You can change the cooking time any time during cooking by repeating Steps 2, 3, and 4.

COOKING AT DIFFERENT COOK POWERS

For best results, some recipes call for different cook powers. The lower the cook power, the slower the cooking. Each Number pad also stands for a different percentage of cook power. Many microwave cookbook recipes tell you by number, percent, or name which cook power to use.

The following chart gives the percentage of cook power each Number pad stands for, and the cook power name usually used. It also tells you when to use each cook power. Follow recipe or food package instructions if available.

NOTE: Refer to a reliable cookbook for cooking times.

COOK POWER	NAME	WHEN TO USE IT
10=100% of full power (automatic)	High	<ul style="list-style-type: none"> ● Quick heating many convenience foods and foods with high water content, such as soups and beverages ● Cooking small tender pieces of meat, ground meat, poultry pieces, fish fillets, and most vegetables
9=90% of full power		<ul style="list-style-type: none"> ● Heating cream soups
8=80% of full power		<ul style="list-style-type: none"> ● Heating rice, pasta, or stirrable casseroles
7=70% of full power	Medium-High	<ul style="list-style-type: none"> ● Cooking and heating foods that need a cook power lower than high (for example, whole fish and meat loaf) or when food is cooking too fast ● Reheating a single serving of food
6=60% of full power		<ul style="list-style-type: none"> ● Cooking sensitive foods, such as cheese and egg dishes, pudding, and custards ● Cooking nonstirrable casseroles, such as lasagna
5=50% of full power	Medium	<ul style="list-style-type: none"> ● Cooking ham, whole poultry, and pot roasts ● Melting chocolate
4=40% of full power		<ul style="list-style-type: none"> ● Simmering stews ● Heating pastries
3=30% of full power	Medium-Low, Defrost	<ul style="list-style-type: none"> ● Defrosting foods, such as bread, fish, meats, poultry, and precooked foods
2=20% of full power		<ul style="list-style-type: none"> ● Softening butter, cheese, and ice cream
1=10% of full power	Low	<ul style="list-style-type: none"> ● Keeping food warm ● Taking chill out of fruit

NOTE: Once cook time has been entered you can also use the COOK POWER pad as a second Minute Timer by entering "0" for the cook power. The oven will count down the cooking time you set without cooking.

1. Put your food in the oven and close the door.

2. Touch COOK TIME.

TOUCH



YOU SEE



COOKING AT DIFFERENT COOK POWERS (CONT.)

3. Enter the cooking time.

Example for 7 minutes, 30 seconds:

TOUCH



YOU SEE



4. Set the cook power.

Example for 50% cook power:

TOUCH



TOUCH



OR



(repeat until desired cook power appears)

YOU SEE



YOU SEE



5. Start the oven.

At the end of the cooking time:

TOUCH



YOU SEE



YOU SEE



(four tones will sound)

Changing instructions

You can change the cooking time or cook power any time during cooking by repeating Steps 2, 3 and/or 4 and 5.

COOKING IN STAGES

For best results, some recipes call for one cook power for a certain length of time, and another cook power for another length of time. Your oven can be set to change from one to another automatically, for up to 3 stages.

You can set your chosen cook functions in any order. However, if you use QUICK DEFROST, it must be the first stage.

NOTE: You cannot sensor cook with stages.

1. Put your food in the oven and close the door.

2. Touch COOK TIME.

TOUCH



YOU SEE



3. Enter the cooking time for the first stage.
Example for 7 minutes, 30 seconds:

TOUCH



YOU SEE



4. Set the cook power for the first stage.

TOUCH



YOU SEE



Example for 50% cook power:

TOUCH



OR



YOU SEE



(repeat until desired cook power appears)

5. Repeat Steps 2, 3, and 4 to set the cooking time and cook power for each additional stage.

COOKING IN STAGES (CONT.)

6. Start the oven.

TOUCH



YOU SEE



(first stage, when cooking with 2 stages)

After the first stage is over, the next stage(s) will count down.

At the end of the cooking time:

YOU SEE



(four tones will sound)

Changing instructions

You can change cooking times or cook powers for a stage any time after that stage starts by repeating Steps 2, 3, and/or 4 and 5.

USING QUICK COOK

You can cook microwavable foods just by choosing a category and quantity. QUICK COOK has preset times and cook powers for 5 categories (see chart below).

To use QUICK COOK, follow the steps below:

1. Touch



You see



2. Touch COOK 1 to 5 times to choose the type of food.

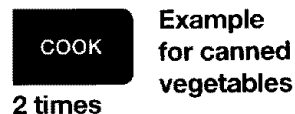

OR

Touch a Number pad to choose the type of food.

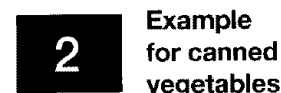

You see

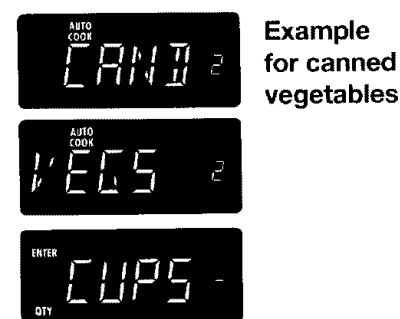

3. Touch one or more Number pads to enter the quantity. **This step is not needed for the Rice setting.**



You see



4. Touch



You see



NOTES:

- If you do not enter a quantity within 2 seconds, QUICK COOK will prompt you to choose a quantity. You then have 1 minute to enter a quantity and to touch START/ENTER. If you do not do so, QUICK COOK will be canceled.
- If you touch COOK 6 times, the display returns to the Rice setting.
- If you need more or less cooking time, do not touch COOK again. Touch COOK POWER before you touch START/ENTER. (See "Changing preset cooking times" in the "Getting to Know" section.)
- When cooking bacon, keep in mind that differences in the amount of fat, meat, thickness, and curing process will affect how bacon is cooked. Also, regular sliced bacon averages about 16 slices per pound.

This chart shows you how to choose a type of food and the amounts you can choose for each type.

FOOD	TOUCH COOK†	OR	TOUCH NUMBER PAD	AMOUNTS YOU CAN CHOOSE
Rice (sensor)	once		1	0.5 to 2 cups†† (118 mL to 473 mL)
Canned Vegetables	twice		2	1 to 4 cups (250 mL to 946 mL)
Bacon	3 times		3	1 to 6 pieces, average thickness
Cereal (instant)	4 times		4	1 to 4 servings
French Toast (frozen)	5 times		5	1 to 4 pieces

† You must touch COOK once before choosing the food type.

†† Because this food is cooked by the sensor, you don't need to enter a quantity. The amount shown here is the amount you can cook. After you choose the food type and touch START/ENTER, "SENSE" appears on the display. Also, the sensor needs 2 minutes, 30 seconds to warm up after the oven is connected to power or after a power failure. If you start sensor cooking during the warm-up, "SENSE" shows on the display until the warm-up is over. Microwave energy will not be turned on until the sensor is warm.

USING QUICK REHEAT

You can reheat microwavable foods just by choosing a category and quantity. QUICK REHEAT has preset times and cook powers for 4 categories (see chart below).

To use QUICK REHEAT, follow the steps below:

1. Touch



once

You see



2. Touch REHEAT 1 to 4 times to choose the type of food.



Example for
casserole

3 times

OR

Touch a Number pad to choose the type of food.



Example for
casserole

You see



Example for
casserole



3. Touch a Number pad to enter the quantity.



Example
for 1 cup

You see



Example
for 1 cup

4. Touch



You see



(countdown time
may vary)

NOTES:

- If you do not enter a quantity within 2 seconds, QUICK REHEAT will prompt you to choose a quantity. You then have 1 minute to enter a quantity and to touch START/ENTER. If you do not do so, QUICK REHEAT will be canceled.
- If you touch REHEAT 5 times, the display returns to the Pizza Slice setting.
- If you need more or less cooking time, do not touch REHEAT again. Touch COOK POWER before you touch START/ENTER. (See "Changing preset cooking times" in the "Getting to Know" section.)

TimeSmart TIP

Reheating baked goods

When reheating a large (4 oz [113 g]) muffin or bagel use the 2-piece setting. The 1-piece setting warms 1 regular-size muffin or bagel, or 2 small dinner rolls.

This chart shows you how to choose a type of food and the amounts you can choose for each type.

FOOD	TOUCH REHEAT†	OR	TOUCH NUMBER PAD	AMOUNTS YOU CAN CHOOSE
Pizza Slice (sensor) ^{††}	once		1	1 to 3 slices, 5 oz (142 g) each
Sauce (sensor) ^{††}	twice		2	1 to 4 cups (250 mL to 946 mL)
Casserole	3 times		3	1 to 4 cups (250 mL to 946 mL)
Baked Goods	4 times		4	1 to 6 pieces, 2 oz (57 g) each

† You must touch REHEAT once before choosing the food type.

†† After you choose the food type and quantity and touch START/ENTER, "SENSE" appears on the display. Also, the sensor needs 2 minutes, 30 seconds to warm up after the oven is connected to power or after a power failure. If you start sensor cooking during the warm-up, "SENSE" shows on the display until the warm-up is over. Microwave energy will not be turned on until the sensor is warm.

USING QUICK DEFROST

You can defrost food by choosing a category and setting a weight. QUICK DEFROST has preset times and cook powers for 3 categories (see chart below).

To use QUICK DEFROST, follow the steps below:

1. Touch



once

You see



2. Touch DEFROST 1 to 3 times to choose the type of food.



once

Example for meats

OR

Touch a Number pad to choose the type of food.



Example for meats

You see



Example for meats



3. Touch Number pad(s) to enter the weight.



Example for 1.1 lbs

twice

You see



Example for 1.1 lbs

4. Touch



You see



(countdown time may vary)

NOTES:

- If you do not enter a weight within 2 seconds, QUICK DEFROST will prompt you to enter a weight. You then have 1 minute to enter a weight and to touch START/ENTER. If you do not do so, QUICK DEFROST will be canceled.
- If you enter a weight higher than the highest weight allowed for your food setting, 3 tones will sound and "RETRY" will appear on the display when you touch START/ENTER.
- If you touch DEFROST 4 times, the display returns to the Meats setting.
- If you need more or less defrosting time, do not touch DEFROST again. Touch COOK POWER before you touch START/ENTER. (See "Changing preset cooking times" in the "Getting to Know" section.)
- See the "Quick defrost chart" later in this section for defrosting directions for each food.
- To defrost items not listed in the "Quick defrost chart," use 30% cook power. Refer to a reliable cookbook for defrosting information.

TimeSmart™ TIP

For even, complete defrosting

- The shape of the package affects how quickly food will defrost. Shallow packages will defrost more quickly than a deep block.
- As food begins to defrost, separate the pieces. Separated pieces defrost more evenly.
- Use small pieces of aluminum foil to shield parts of food such as chicken wings, leg tips, fish tails, or areas that start to get warm. Make sure the foil does not touch the sides, top, or bottom of the oven.

This chart shows you how to choose a type of food and the weights you can set for each type.

FOOD	TOUCH DEFROST†	OR	TOUCH NUMBER PAD	WEIGHTS YOU CAN SET (tenths of a pound)
Meats	once		1	.1 to 6.6 (45 g to 2994 g)
Poultry	twice		2	.1 to 6.6 (45 g to 2994 g)
Fish	3 times		3	.1 to 4.4 (45 g to 1998 g)

† You must touch DEFROST once before choosing the food type.



QUICK DEFROST CHART

Meat setting

FOOD	SPECIAL INSTRUCTIONS
Beef	Meat of irregular shape and large, fatty cuts of meat should have the narrow or fatty areas shielded with foil at the beginning of a defrost cycle.
Ground Beef, Bulk	Do not defrost less than ¼ lb (113 g).
Ground Beef, Patties	Do not defrost less than two 4 oz (113 g) patties.
Round Steak, Tenderloin Steak, Pot Roast, Chuck Roast, Rib Roast, Rolled Rump Roast	Place on a microwavable roasting rack.
Stew Beef	Place in a microwavable baking dish.
Lamb	
Cubes for Stew	Place in a microwavable baking dish.
Chops (1 inch [2.5 cm] thick)	Place on a microwavable roasting rack.
Pork	
Chops (½ inch [13 mm] thick), Hot Dogs, Spareribs, Country-Style Ribs, Loin Roast (Boneless), Sausage, Links	Place on a microwavable roasting rack.
Sausage, Bulk	Place in a microwavable baking dish.

Fish setting

FOOD	SPECIAL INSTRUCTIONS
Fish	
Fillets	Place in a microwavable baking dish. Carefully separate fillets under cold water.
Steaks	Place in a microwavable baking dish. Run cold water over to finish defrosting.
Whole	Place in a microwavable baking dish. Cover head and tail with foil; do not let foil touch sides of microwave oven. Finish defrosting by immersing in cold water.
Shell Fish	
Crabmeat, Lobster Tails, Shrimp, Scallops	Place in a microwavable baking dish.

continued on next page



QUICK DEFROST CHART (CONT.)

Poultry setting

FOOD	SPECIAL INSTRUCTIONS
Chicken	
Whole (up to 9½ lbs [4.3 kg])	Place chicken breast-side up on a microwavable roasting rack. Finish defrosting by immersing in cold water. Remove giblets when chicken is partially defrosted.
Cut Up	Place on a microwavable roasting rack. Finish defrosting by immersing in cold water.
Cornish Hens	
Whole	Place on a microwavable roasting rack. Finish defrosting by immersing in cold water.
Turkey	
Breast (under 6 lbs [2.7 g])	Place on a microwavable roasting rack. Finish defrosting by immersing in cold water.

DEFROSTING TIPS

- When using QUICK DEFROST, you need to enter the net weight (the weight of the food minus the container). Enter the weight to the nearest ¼ lb (45 g).
- Only use QUICK DEFROST for raw food. QUICK DEFROST gives best results when the food to be thawed is completely frozen. If the food is partially defrosted, always set a lower food weight (for a shorter defrosting time) to prevent cooking the food.
- For better results, a preset standing time is included in the defrosting time. This may make the defrosting time seem longer than expected. (For more information on standing time, see the "Microwave cooking tips" in the "Cooking Guide" section.)

Weight conversion chart

You are probably used to food weights as being in pounds and ounces that are fractions of a pound (for example 4 ounces equals ¼ pound). However, in order to enter food weight in QUICK DEFROST, you must specify pounds and tenths of a pound.

If the weight on the food package is in fractions of a pound, you can use the following chart to convert the weight to decimals.

DECIMAL WEIGHT	EQUIVALENT OUNCE WEIGHT	EQUIVALENT GRAM WEIGHT
.10	1.6	45
.20	3.2	91
.25 One-Quarter Pound	4.0	113
.30	4.8	136
.40	6.4	181
.50 One-Half Pound	8.0	227
.60	9.6	272
.70	11.2	318
.75 Three-Quarters Pound	12.0	340
.80	12.8	363
.90	14.4	408
1.00 One Pound	16.0	454

Using ACCU-SIMMER

Your microwave oven lets you simmer soups, casseroles, stews, and other liquid foods. All you do is set a simmer time and your oven will bring your food to a boil and then simmer it for the time you specify.

NOTES:

- You cannot change the cook power or doneness for ACCU-SIMMER.
- This function uses the sensor. The sensor needs

1. Place the food in the oven and shut the door.

2. Touch ACCU-SIMMER.

2 minutes, 30 seconds to warm up after the oven is connected to power or after a power failure. If you start ACCU-SIMMER during the warm-up, microwave energy will not be turned on until the sensor is warm.

- When cooking vegetables, increase amount of water to $\frac{1}{4}$ to $\frac{1}{2}$ cup (60 to 125 mL).
- Cover dish with a hard lid, i.e. the lid that comes with the dish or a dinner plate. Do not use plastic wrap.

3. Touch Number pads to enter the simmer time.

Example for 30 minutes:

TOUCH



YOU SEE



TOUCH

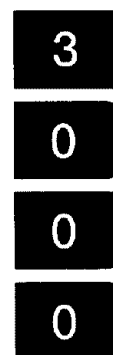

YOU SEE



4. Touch START/ENTER.

The oven will bring the food to a boil.

TOUCH



YOU SEE



The food will then simmer for the time you set.

YOU SEE



When simmering foods like pasta

Use a container that can hold enough water to cover the food completely when cooking, such as a 3-quart (12-cup [2.84 L]) casserole with a lid. When cooking pasta or noodles, add 1 tbsp (15 mL) oil to the water before boiling. Use the following method.

Place container with water in the oven and follow Steps 2-4, setting the simmer time at 1 second. At the end of the signal, place the food in the water and stir until completely covered by water. Cover. Repeat Steps 2-4, setting the simmer time you want.

Changing instructions

You can change the simmering time while simmering by repeating Steps 2, 3, and 4.

USING SENSOR ONE TOUCH COOKING

Food releases humidity during cooking/heating. How much humidity food releases is affected by the quantity, temperature, and shape of the food. Your microwave oven has a sensor that detects this humidity. The amount of humidity detected tells the oven how long to cook or heat your food. You can use SENSOR ONE TOUCH cooking when preparing any of 8 types of food. Just touch the pad for the food you want to cook or heat (see the chart below).

To use SENSOR ONE TOUCH cooking:

1. Touch a SENSOR ONE TOUCH pad.



Example for baked potato

You see



(until cooking time is estimated)



("MAX" appears every 3 seconds)

NOTES:

- You do not need to touch START/ENTER to start the oven. The oven will start cooking/

heating when you touch one of the SENSOR ONE TOUCH pads.

- If you need more or less cooking time, do not touch the selected SENSOR ONE TOUCH pad again. Touch COOK POWER within 20 seconds after choosing the food type. (See "Changing preset cooking times" in the "Getting to Know" section.) You cannot change preset cooking times for POPCORN.
- The sensor needs 2 minutes, 30 seconds to warm up after the oven is connected to power or after a power failure. If you start sensor cooking during the warm-up, "SENSE" shows on the display until the warm-up is over. Microwave energy will not be turned on until the sensor is warm.
- When cooking foods for a long time, allow the oven to cool down before sensor cooking again.

TimeSmart™ TIP

Popcorn brands make a difference

How well your popcorn cooks will depend on the brand of popcorn and how much fat it has in it. Try several brands to decide which pops the best. For best results, use fresh bags of popcorn.

This chart shows you how to choose a type of food and the amount you can choose for each type.

PAD	INSTRUCTIONS	AMOUNT
Popcorn†	Pop only 1 package at a time. If you are using a microwave popcorn popper, follow manufacturer's instructions.	3.5 oz (100 g), 3.0 oz (85 g), 1.75 oz (50 g)
Baked Potato	Before baking, remember to pierce the potato with a fork several times. After cooking, let the potato stand 5 minutes to finish cooking.	1 to 4 potatoes (10 oz [284 g] to 13 oz [369 g] each)
Fresh Vegetable	Prepare as you want, wash, but do not dry vegetables. Place vegetables in a correct-size microwavable container. Add 2 to 4 tbsp (30 to 60 mL) water. Cover with plastic wrap and vent.	1 to 4 cups (250 mL to 946 mL)
Frozen Vegetable	Remove from package, rinse off frost under running water. Place vegetables in a correct-size microwavable container. Add 2 to 4 tbsp (30 to 60 mL) water. Cover with plastic wrap and vent.	1 to 4 cups (250 mL to 946 mL)
Frozen Entree	Loosen the covering for venting.	10- or 20-ounce (284 g or 568 g)
Beverage†	Do not cover. The shape of the mug will affect how the contents heat – if narrow and tall, contents may be hotter; if more open area on top (i.e. 1-cup [250 mL] measuring cup) contents may be cooler.	1 or 2 8-ounce (250 mL) cups

† The display does not show cooking time for this setting. "SENSE" stays on the display until cooking is finished.



USING SENSOR ONE TOUCH COOKING (CONT.)

PAD	INSTRUCTIONS	AMOUNT
Dinner Plate	Place food to be heated on a dinner plate or similar dish. Cover with plastic wrap and vent.	1 serving (or 1 plate) (0.5 to 1 lb [.2 k to .45 k])
Soup	Place soup to be heated in a correct-size microwavable container. Cover with plastic wrap and vent.	1 to 4 cups (250 mL to 946 mL)

USING WARM HOLD

You can safely keep hot, cooked food warm in your microwave oven for up to 99 minutes, 99 seconds (about 1 hour, 40 minutes). You can use WARM HOLD by itself, or to automatically follow a cooking cycle.

NOTES:

- WARM HOLD operates for up to 99 minutes, 99 seconds.
- Opening the oven door cancels WARM HOLD. Close the door and touch WARM HOLD, then touch START/ENTER if additional WARM HOLD time is desired.

- Food cooked covered should be covered during WARM HOLD.
- Pastry items (pies, turnovers, etc.) should be uncovered during WARM HOLD.
- Complete meals kept warm on a dinner plate should be covered during WARM HOLD.
- Do not use more than one complete WARM HOLD cycle (about 1 hour, 40 minutes). The quality of some foods will suffer with extended time.

1. Put hot, cooked food in the oven and close the door.

2. Touch WARM HOLD.

TOUCH



YOU SEE



3. Start the oven.

TOUCH



YOU SEE



To make WARM HOLD automatically follow another cycle:

- While you are entering cooking instructions, touch WARM HOLD before touching START/ENTER, or during cooking.
- When the last cooking cycle is over, you will hear two tones. "WARM" will come on while the oven continues to run.

CARING FOR YOUR MICROWAVE OVEN

To make sure your microwave oven looks good and works well for a long time, you should maintain it properly. For proper care, please follow these instructions carefully.

For interior surfaces: Wash often with warm, sudsy water and a sponge or soft cloth. Use only mild, nonabrasive soaps or a mild detergent. **Be sure to keep the areas clean where the door and oven frame touch when closed.** Wipe well with clean water. Over time, stains can occur

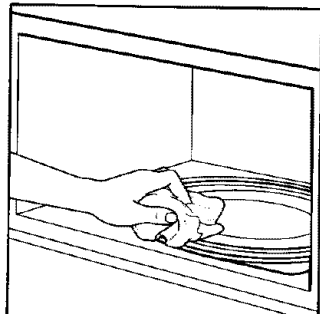

on the surfaces as the result of food particles spattering during cooking. This is normal.

For stubborn soil, boil a cup of water in the oven for 2 or 3 minutes. Steam will soften the soil. To get rid of odors inside the oven, boil a cup of water with some lemon juice or vinegar in it.

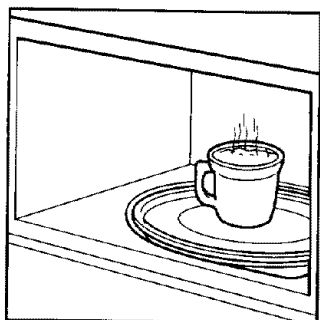

For exterior surfaces and control panel: Use a soft cloth with spray glass cleaner. Apply the spray glass cleaner to the soft cloth; do not spray directly on the oven.

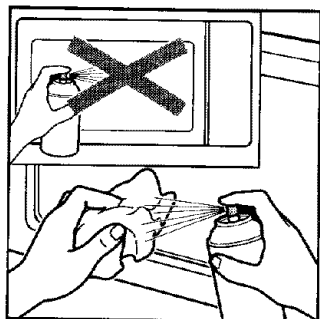

NOTE: Abrasive cleansers, steel-wool pads, gritty wash cloths, some paper towels, etc., can damage the control panel and the interior and exterior oven surfaces.

To clean turntable and turntable support, wash in mild, sudsy water; for heavily soiled areas use a mild cleanser and scouring sponge. The turntable and turntable support are dishwasher safe.

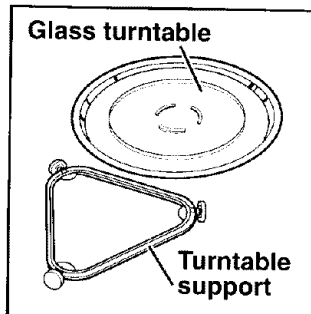

Cleaning the cooking rack

- Wash by hand with a mild detergent and a soft sponge or nylon scrub brush. Dry completely.
- Do not use abrasive scrubbers or cleansers to clean rack.
- The rack is dishwasher safe.

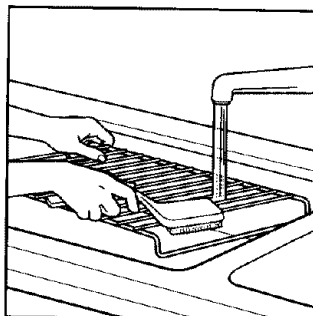

INSTALLING AND CARING FOR THE FILTERS

Do not allow grease and soil to build up in the grease filters. It will decrease the exhaust fan efficiency and could cause a fire. Remove and clean grease filters at least once a month.

NOTE: Your microwave hood combination comes with a charcoal filter to provide clean recirculated air. **The charcoal filter cannot be cleaned and should be replaced every 6 to 12 months.** You can order replacements (PN 4393690) in the U.S.A. by calling **1-800-253-1301**, or in Canada by calling the nearest service branch (see "If you need assistance or service in Canada" in the "Requesting Assistance or Service" section). Follow the instructions and telephone prompts you hear.

⚠ WARNING



Electrical Shock Hazard
Disconnect power before removing filters.
Replace all panels before operating.
Failure to do so can result in death or electrical shock.

Removing, cleaning, and replacing

1. Unplug microwave oven or disconnect power.

2. To remove the grease filters (PN 4393691), push

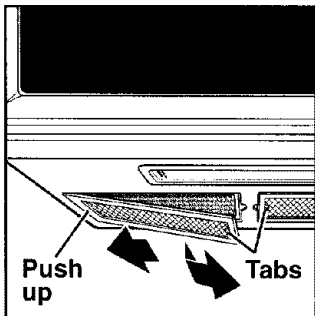

each filter up on the side opposite the tab. Grasp the tab and slide the filter to the side. Pull the filter downward. It will drop out.

3. To remove the charcoal filters, push the back of each filter away from you. This will slide the front of the filter off the lower lip. Swing the front of the filter down and slide the filter out.

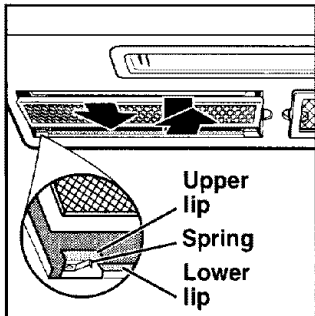

4. Soak grease filters in hot water and a mild detergent. Scrub and swish to remove embedded dirt and grease. Rinse well and shake to dry.

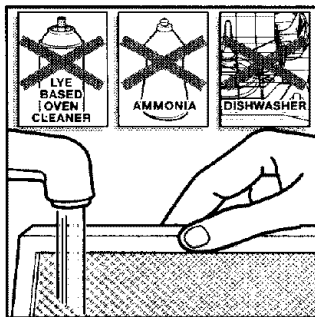

Do not use ammonia, corrosive cleaning agents such as lye-based oven cleaners, or place in a dishwasher. The filter will turn black or could be damaged.

5. To replace the charcoal filters, push each filter

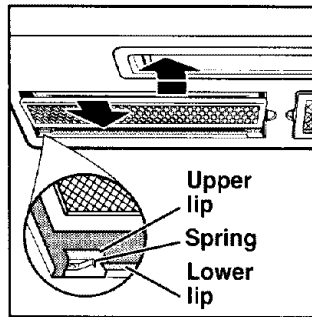

to the back of the opening, between the upper and lower lips against the springs. Swing the front of the filter up against the upper lip. Slide the filter forward while pushing it up against the upper lip. The filter will now be held in position between the lips by the spring.

6. To replace the grease filters, slide each filter into the outer side of the filter opening. Make sure you are sliding in the side of the filter that does not have the tab.

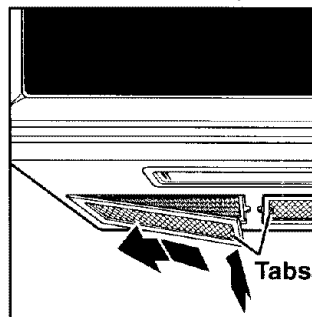

Hold the tab with your other hand. Push up the tab side of the filter and slide the filter to the other side of the opening to lock into place.

7. Plug in microwave oven or reconnect power.

NOTE: Do not operate the vent fan without the filters in place.

REPLACING THE COOKTOP AND OVEN LIGHTS

The cooktop light

1. Unplug microwave oven or disconnect power.
2. Remove the bulb cover mounting screw and carefully remove the cover.

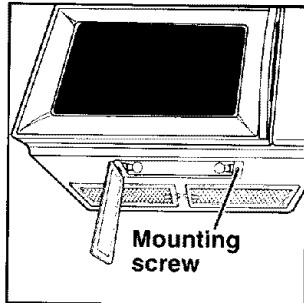

3. Replace bulb(s) with candelabra-base 30-watt bulb(s) (PN 4393681).†
4. Replace the bulb cover and mounting screw.
5. Plug in microwave oven or reconnect power.

The oven light

1. Unplug microwave oven or disconnect power.
2. Remove the two vent grille mounting screws located above the cover (the two outer screws).

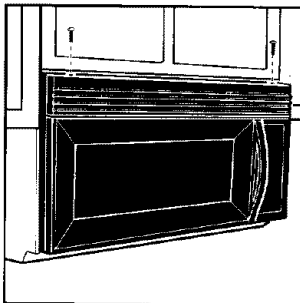

3. Tip the grille forward, then lift out to remove.

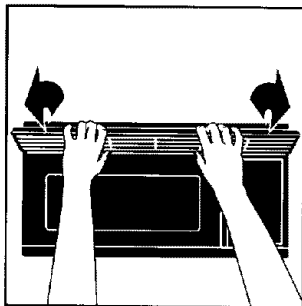

4. Lift up the bulb cover.

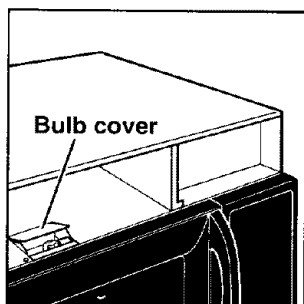

5. Replace the bulb with a candelabra-base 30-watt bulb (PN 4393681).†
6. Close the bulb cover.
7. Slide the top of the vent grille into place.

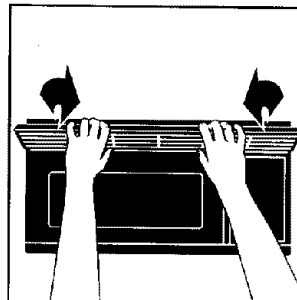

Push the bottom until it snaps into place. Replace the mounting screws.

8. Plug in microwave oven or reconnect power.

† To order bulbs in the U.S.A. call **1-800-253-1301**, or in Canada call the nearest service branch (see "If you need assistance or service in Canada" in the "Requesting Assistance or Service" section). Follow the instructions and telephone prompts you hear.

COOKING GUIDE

MICROWAVE COOKING TIPS

Amount of food

- **If you increase or decrease** the amount of food you prepare, the time it takes to cook that food will also change. For example, if you double a recipe, add a little more than half the original cooking time. Check for doneness and, if necessary, add more time in small increments.

Starting temperature of food

- **The lower the temperature** of the food being put into the microwave oven, the longer it takes to cook. Food at room temperature will be reheated more quickly than food at refrigerator temperature.

Composition of food

- **Food with a lot of fat and sugar** will be heated faster than food containing a lot of water. Fat and sugar will also reach a higher temperature than water in the cooking process.
- **The more dense the food**, the longer it takes to heat. "Very dense" food like meat takes longer to reheat than lighter, more porous food like sponge cakes.

Size and shape

- **Smaller pieces of food** will cook faster than larger pieces. Also, same-shaped pieces cook more evenly than different-shaped pieces.
- **With foods that have different thicknesses**, the thinner parts will cook faster than the thicker parts. **Place** the thinner parts of chicken wings and legs in the center of the dish.

Stirring, turning foods

- **Stirring and turning foods** spreads heat quickly to the center of the dish and avoids overcooking at the outer edges of the food.

Covering food

Cover food to:

- **Reduce** splattering
- **Shorten** cooking times
- **Keep** food moist

You can use any covering that lets microwaves pass through.

Releasing pressure in foods

- **Several foods** (for example: baked potatoes, sausages, egg yolks, and some fruits) are tightly covered by a skin or membrane. Steam can build up under the membrane during cooking, causing the food to burst. To relieve the pressure and to prevent bursting, **pierce** these foods before cooking with a fork, cocktail pick, or toothpick.

Using standing time

- **Always allow food to stand** after cooking. Standing time after defrosting and cooking allows the temperature to evenly spread throughout the food, improving the cooking results.
- **The length of the standing time** depends on how much food you are cooking and how dense it is. Sometimes it can be as short as the time it takes you to remove the food from the oven and take it to the serving table. However, with larger, denser food, the standing time may be as long as 10 minutes.

continued on next page

MICROWAVE COOKING TIPS (CONT.)

Arranging food

For best results, place food evenly on the plate. You can do this in several ways:

- **If you are cooking several items of the same food**, such as baked potatoes, **place** them in a ring pattern for uniform cooking.
- **When cooking foods of uneven shapes or thickness, such as chicken breasts, place** the smaller or thinner area of the food towards the center of the dish where it will be heated last.
- **Layer thin slices of meat** on top of each other.
- **When you cook or reheat whole fish, score** the skin – this prevents cracking.
- **Do not** let food or a container touch the top or sides of the oven. This will prevent possible arcing.

Using aluminum foil

Metal containers should not be used in a microwave oven. There are, however, some exceptions. If you have purchased food which is prepackaged in an aluminum foil container, refer to the instructions on the package. When using aluminum foil containers, cooking times may be longer because microwaves will only penetrate the top of the food.

If you use aluminum containers without package instructions, follow these guidelines:

- **Place** the container in a glass bowl and add some water so that it covers the bottom of the container, not more than ¼ inch (6 mm) high. This ensures even heating of the container bottom.
- **Always remove** the lid to avoid damage to the oven.
- **Use only** undamaged containers.
- **Do not use** containers taller than ¾ inch (19 mm).
- **Container must be** at least half filled.
- **To avoid arcing**, there must be a minimum ¼ inch (6 mm) between the aluminum container and the walls of the oven and also between two aluminum containers.
- **Always place** the container on the turntable.
- **Reheating food** in aluminum foil containers usually takes up to double the time compared to reheating in plastic, glass, china, or paper containers. The time when food is ready will vary depending upon the type of container you use.
- **Let food stand** for 2 to 3 minutes after heating so that heat is spread evenly throughout container.

Cooking you should not do in your microwave oven

- **Do not** do canning of foods in the oven. Closed glass jars may explode, resulting in damage to the oven or possible personal injury.
- **Do not** use the microwave oven to sterilize objects (baby bottles, etc.). It is difficult to keep the oven at the high temperature needed for safe sterilization.

QUESTIONS AND ANSWERS

QUESTIONS	ANSWERS
Can I operate my microwave oven without the turntable or turn the turntable over to hold a large dish?	You can turn off the turntable to heat 2 dinner plates side by side or one dish that's larger than the turntable. However, if you only need to heat one plate on the turntable, keep the turntable on for best cooking results. Also, you should not turn over the turntable. A plate used on the turntable must fit on it when the turntable is correct side up.
Can I use a rack in my microwave oven so that I may reheat or cook on two levels at a time?	You can use a rack only if the rack is supplied with your microwave oven. If you use a rack not supplied with the microwave oven, you can get poor cooking performance and/or arcing.
Can I use either metal or aluminum pans in my microwave oven?	You can use aluminum foil for shielding (use small, flat pieces), small skewers, and shallow foil trays (if tray is 3/4 inch [19 mm] deep or less and half filled with food to absorb microwave energy). Never allow metal to touch walls or door. (For more information, see "Using aluminum foil" in the "Cooking Guide" section.)
Is it normal for the turntable to turn in either direction?	Yes. The turntable rotates clockwise or counter-clockwise, depending on the rotation of the motor when the cooking cycle begins.
Sometimes the door of my microwave oven appears wavy. Is this normal?	This appearance is normal and does not affect the operation of your oven.
What are the humming noises that I hear when my microwave oven is operating?	You hear the sound of the transformer when the magnetron tube cycles on.
Why does the dish become hot when I microwave food in it? I thought that this should not happen.	As the food becomes hot it will conduct the heat to the dish. Be prepared to use hot pads to remove food after cooking.
What does "standing time" mean?	"Standing time" means that food should be removed from the oven and covered for additional time to allow it to finish cooking. This frees the oven for other cooking.
Why does steam come out of the air exhaust vent?	Steam is normally produced during cooking. The microwave oven has been designed to vent this steam out the vent.
Can I pop popcorn in my microwave oven? How do I get the best results?	Yes. Pop packaged microwave popcorn following manufacturer's guidelines or use the sensor POPCORN pad. Do not use regular paper bags. Use the "listening test" by stopping the oven as soon as the popping slows to a "pop" every 1 or 2 seconds. Do not repop unpopped kernels. Do not pop popcorn in glass cookware.

TROUBLESHOOTING

Most cooking problems often are caused by little things you can find and fix without tools of any kind. Check the lists below and on the next page before calling for assistance or service. If you still need help, see the “Requesting Assistance or Service” section on page 44 or 45.

MICROWAVE OVEN DOES NOT WORK

PROBLEM	CAUSE
Nothing works.	<ul style="list-style-type: none">● The power supply cord is not plugged into a live circuit with the proper voltage. (See the “Electrical requirements” section on page 5 and the “Electrical connection” section on page 12.)● A household fuse has blown or a circuit breaker has tripped.● The electric company has had a power failure.
The microwave oven will not run.	<ul style="list-style-type: none">● You are using the oven as a timer. Touch TIMER OFF to cancel the Minute Timer.● The door is not firmly closed and latched.● You did not touch START/ENTER.● You did not follow directions exactly.● An operation that you set earlier is still running. Touch OFF/CANCEL to cancel that operation.

COOKING TIMES

PROBLEM	CAUSE
Food is not cooked enough.	<ul style="list-style-type: none">● The electric supply to your home or wall outlets is low or lower than normal. Your electric company can tell you if the line voltage is low. Your electrician or service technician can tell you if the outlet voltage is low.● The cook power is not at the recommended setting. Check the chart on page 24.● You have not allowed enough cooking time for the amount of food being cooked. Larger amounts of food need longer cooking times.
The display shows a time counting down but the oven is not cooking.	<ul style="list-style-type: none">● The oven door is not closed completely.● You have set the controls as a minute timer. Touch TIMER OFF to cancel the Minute Timer.

TURNTABLE

PROBLEM	CAUSE
The turntable will not turn.	<ul style="list-style-type: none"> ● You have turned off the turntable. (See the “Heating more than one plate of food” section on page 17.) ● The turntable is not correctly in place. It should be correct-side up and sitting firmly on the center shaft. ● The support is not operating correctly. Remove the turntable and restart the oven. If the support still does not move, call an authorized service technician for repair. Cooking without the turntable can give you poor results.

TONES

PROBLEM	CAUSE
You do not hear the programming or end-of-cycle tone.	<ul style="list-style-type: none"> ● You have not entered the correct command. ● You have turned off the tone. (See the “Audible signals” section on page 16.)

DISPLAY MESSAGES

PROBLEM	CAUSE
The display is flashing “:.”.	<ul style="list-style-type: none"> ● There has been a power interruption. Reset the clock. (See the “Setting the clock” section on page 20.)

If none of these items are causing your problem, see the “Requesting Assistance or Service” section on page 44.

REQUESTING ASSISTANCE OR SERVICE

To avoid unnecessary service calls, please check the "Troubleshooting" section. It may save you the cost of a service call. If you still need help, follow the instructions below.

IF YOU NEED ASSISTANCE OR SERVICE IN U.S.A.

Call the Whirlpool Consumer Assistance



Center toll free at 1-800-253-1301.
Our consultants are available to assist you.

When calling:

Please know the purchase date, and the complete model and serial number of your appliance (see the "A Note to You" section). This information will help us better respond to your request.

Our consultants provide assistance with:

- Features and specifications on our full line of appliances
- Installation information
- Use and maintenance procedures

- Accessory and repair parts sales
- Specialized customer assistance (Spanish speaking, hearing impaired, limited vision, etc.)
- Referrals to local dealers, service companies, and repair parts distributors

Whirlpool service technicians are trained to fulfill the product warranty and provide after-warranty service, anywhere in the United States.

To locate the authorized Whirlpool service company in your area, you can also look in your telephone directory Yellow Pages.

FOR FURTHER ASSISTANCE

If you need further assistance, you can write to Whirlpool with any questions or concerns at:

Whirlpool Brand Home Appliances
Consumer Assistance Center
c/o Correspondence Dept.
2000 North M-63
Benton Harbor, MI 49022-2692

Please include a daytime phone number in your correspondence.

IF YOU NEED ASSISTANCE OR SERVICE IN CANADA

1. If the problem is not due to one of the items listed in "Troubleshooting"†...

Contact the dealer from whom you purchased your appliance, or call the Inglis Limited Consumer Assistance Centre toll free, **8:30 a.m. – 6 p.m. (EST)**, at **1-800-461-5681**.



2. If you need service†...

Contact your nearest Inglis Limited Appliance Service branch or authorized servicing outlet to service your appliance. (See list below.)

† When asking for assistance or service, please provide a detailed description of the problem, your appliance's complete model and serial numbers, and the purchase date. (See the "A Note to You" section.) This information will help us respond properly to your request.

Inglis Limited Appliance Service – Consumer Services

Direct service branches:

BRITISH COLUMBIA		1-800-665-6788
ALBERTA		1-800-661-6291
ONTARIO (except 807 area code)	Ottawa area Outside the Ottawa area	1-800-267-3456 1-800-807-6777
MANITOBA, SASKATCHEWAN and 807 area code in ONTARIO		1-800-665-1683
QUEBEC	Montreal (except South Shore) South Shore Montreal Quebec City Sherbrooke	1-800-361-3032 1-800-361-0950 1-800-463-1523 1-800-567-6966
ATLANTIC PROVINCES		1-800-565-1598

FOR FURTHER ASSISTANCE

If you need further assistance, you can write to Inglis Limited with any questions or concerns at:

Consumer Relations Department
Inglis Limited
1901 Minnesota Court
Mississauga, Ontario L5N 3A7

Please include a daytime phone number in your correspondence.

INDEX

This index is alphabetical. It contains all the topics included in this manual, along with the page(s) on which you can find each topic.

TOPIC	PAGE	TOPIC	PAGE
ALUMINUM FOIL.....	30, 40	ELECTRICAL REQUIREMENTS.....	5, 12
AUDIBLE SIGNALS	16	EXHAUST FAN	19
CARING FOR YOUR MICROWAVE OVEN	36	FILTERS	37
CHARTS		HOW YOUR MICROWAVE OVEN WORKS	9-10
Cook powers	24	INSTALLATION INSTRUCTIONS	6-8
Quick cook	28	LIGHTS	
Quick defrost	30, 31-32	Replacing	38
Quick reheat	29	Using	19
Sensor one touch cooking	34-35	PARTS AND FEATURES	
Weight conversion	32	Cooking guide label	13
CONTROL PANEL	14-17	Cooking rack	13, 18
ACCU-SIMMER	33	Door handle	13
ADD MINUTE	22	Door safety lock system	13
BAKED POTATO.....	34	Magnetron	9, 41
BEVERAGE.....	34	Microwave inlet cover	13
Changing preset cooking times	22	Model and serial number plate	13
Child lock	17	Turntable	9, 12, 13, 36, 41, 43
CLOCK.....	20	Vent grille	13
COOK.....	28	Window	13
Cooking at high cook power	23	QUESTIONS AND ANSWERS	41
Cooking at different cook powers	24-25	RACK	18, 41
COOK POWER	22, 23, 24, 25, 26	RADIO INTERFERENCE	10
COOK TIME	23, 24, 26	REPLACING COOKTOP AND OVEN LIGHTS	38
DEFROST.....	30	REQUESTING ASSISTANCE OR SERVICE	44-45
Demo/learning feature	17	SAFETY	3-5, 11-12
DINNER PLATE	35	STANDING TIME	32, 39, 41
Display	14	TESTING YOUR DINNERWARE OR COOKWARE	11
Fan	19	TESTING YOUR MICROWAVE OVEN	10
FRESH VEGETABLE.....	34	TIPS	
FROZEN ENTREE	34	Cooking	39, 40
FROZEN VEGETABLE	34	Defrosting	30, 32
Interrupting cooking	16	Popcorn	34
Light	19	TROUBLESHOOTING	42-43
Minute timer	21	WARRANTY	48
Number pads	15		
OFF/CANCEL.....	16		
POPCORN	34		
REHEAT	29		
Sensor cooking	34		
SOUP	35		
Stage cooking.....	26-27		
START/ENTER	16		
TIMER OFF	21		
TIMER SET.....	21		
TURNTABLE ON/OFF	17		
WARM HOLD	35		

U.S.A. WARRANTY

WHIRLPOOL MICROWAVE OVEN

LENGTH OF WARRANTY	WHIRLPOOL WILL PAY FOR
FULL ONE-YEAR WARRANTY FROM DATE OF PURCHASE	FSP* replacement parts and repair labor to correct defects in materials or workmanship. Service must be provided by an authorized Whirlpool service company.
LIMITED FOUR-YEAR WARRANTY SECOND THROUGH FIFTH YEAR FROM DATE OF PURCHASE	FSP replacement magnetron tube on microwave ovens if defective in materials or workmanship.
WHIRLPOOL WILL NOT PAY FOR	
<p>A. Service calls to:</p> <ol style="list-style-type: none"> 1. Correct the installation of your microwave oven. 2. Instruct you how to use your microwave oven. 3. Replace house fuses or correct house wiring. 4. Replace owner-accessible light bulbs. <p>B. Repairs when your microwave oven is used in other than normal, single-family household use.</p> <p>C. Pickup and delivery. Your microwave oven is designed to be repaired in the home.</p> <p>D. Damage to your microwave oven caused by accident, misuse, fire, flood, acts of God, or use of products not approved by Whirlpool.</p> <p>E. Any labor costs during limited warranty.</p> <p>F. Repairs to parts or systems resulting from unauthorized modifications made to the appliance.</p>	

9/97

WHIRLPOOL CORPORATION SHALL NOT BE LIABLE FOR INCIDENTAL OR CONSEQUENTIAL DAMAGES.

Some states do not allow the exclusion or limitation of incidental or consequential damages, so this exclusion or limitation may not apply to you. This warranty gives you specific legal rights, and you may also have other rights which vary from state to state.

Outside the United States, a different warranty may apply. For details, please contact your authorized Whirlpool dealer.

If you need assistance or service, first see the "Troubleshooting" section of this book. After checking "Troubleshooting," additional help can be found by checking the "Requesting Assistance or Service" section. In the U.S.A., call our Consumer Assistance Center at **1-800-253-1301**.

For warranty information in Canada:

Please contact your authorized Whirlpool dealer or call the Consumer Assistance Centre at **1-800-461-5681** (toll free) between 8:30 a.m. and 6 p.m. EST from anywhere in Canada.

For service or assistance in Canada:

If you need assistance or service in Canada, first see the "Troubleshooting" section of this book. After checking "Troubleshooting," additional help can be found by checking the "Requesting Assistance or Service" section.

PART NO. 8169421 4619-652-55304