

# Rinnai

## Installation Manual

### HOTFLO (EHFA/EHFD) Series

Mains Pressure Vitreous Enamel  
Electric Storage Water Heater



#### This appliance must be installed in accordance with:

- Manufacturer's Installation Instructions
  - Municipal Building Codes
  - Current AS/NZS 3000 Wiring Rules
  - Current AS/NZS 3500.4 Plumbing and Drainage - Heated Water Services
  - All local regulatory requirements, including all local OH&S requirements
- This appliance must be installed, maintained and removed by a Qualified Person.  
For continued safety of this appliance it must be installed and maintained in accordance with the manufacturers instructions.

Certified  
Product



WaterMark

This Appliance complies  
with current AS 3498  
SAI GLOBAL LIC. WMKA00169



N10378



This page is intentionally blank



# TABLE OF CONTENTS

<b>Warnings &amp; Safety</b>	<b>5</b>
Regulatory .....	5
Notice To Victorian Consumers .....	5
Safety .....	6
Hydrogen Gas .....	6
Water Temperature .....	6
Scald Hazards .....	6
Safety Devices .....	7
Pressure & Temperature Relief (PTR) Valve .....	7
Expansion Control Valve (ECV) .....	7
<b>Important Information</b>	<b>8</b>
Anode .....	8
Water Quality .....	8
Operational Overview .....	8
Turning Water Heating System 'OFF' .....	8
Turning Water Heating System 'ON' .....	8
Draining .....	8
<b>Care &amp; Maintenance</b>	<b>9</b>
Save A Service Call .....	9
Periodic Maintenance & Servicing .....	9
<b>Specifications</b>	<b>10</b>
Appliance Components .....	10
Table 1. Dimensions & Weight .....	11
Table 2. Ratings & Other Specifications .....	11
<b>Installation Methods</b>	<b>12</b>
Hot Water Plumbing System Example - No TLD .....	12
Hot Water Plumbing System Example - With TLD .....	12
Hot Water Plumbing system Example / Flow & Return Pipe Work - No TLD .....	13
Hot Water Plumbing System Example / Flow & Return Pipe Work - With TLD .....	13
<b>Installation</b>	<b>14</b>
Location .....	14
Water Quality .....	14
Mains Pressure .....	14
THERMOSTAT SETTING .....	15
Reducing The Risk Of Scalding .....	15
Plumbing Connections .....	15
Connections to the water heater .....	15
Water Pipes .....	15
Pressure and Temperature Relief (PTR) Valve .....	16
Expansion Control Valve (ECV) .....	16
Pressure Limiting Valve (PLV) .....	16
Relief Valve Drain Lines .....	16
Electrical Supply .....	17
Electrical Connections .....	17
Wiring Diagrams .....	18
Thermostat Setting .....	18
<b>Commissioning</b>	<b>19</b>
To fill & turn 'ON' the water heater .....	19
To turn 'OFF' the water heater .....	19
<b>Contacts</b>	<b>20</b>





This page is intentionally blank



# WARNINGS & SAFETY



## READ ALL INSTRUCTIONS BEFORE USING THE APPLIANCE.

Always comply with the following precautions to avoid dangerous situations and to ensure optimum performance.

Failure to carefully read and follow all instructions in this manual can result in equipment malfunction, property damage, personal injury and/or death.

Your Rinnai Hotflo Mains Pressure Vitreous Enamel Electric Storage Water Heater has been certified by relevant plumbing and electrical authorities and the details are shown on data plate.

**WARNINGS:** WHEN IGNORED, CAN RESULT IN SERIOUS INJURY OR DEATH.

**CAUTIONS:** WHEN IGNORED, CAN RESULT IN MINOR INJURY OR PRODUCT DAMAGE.

## REGULATORY



This appliance shall be installed in accordance with these instructions and all regulatory requirements which exist in your area including those in relation to manual lifting, working at heights and on roofs. Applicable publications and regulations may include:

- AS/NZS 3500 National Plumbing and Drainage
- AS/NZS 3000 Wiring rules
- Building Codes of Australia (BCA)
- Local Occupational Health and Safety (OH&S) regulations
- Local Regulations and Municipal Building Codes

**DO NOT** operate this system before reading the manufacturers instructions.

This appliance must be installed, commissioned and serviced by an authorised person in accordance with all applicable local rules and regulations.

For continued safety of this appliance it must be installed, operated and maintained in accordance with the manufacturer's instructions.

This appliance is heavy, use 2 people or mechanical lifting device. Improper lifting may result in serious injury.

Take care when opening or unpacking this appliance. Failure to do so may result in serious injury or product failure.

**DO NOT** modify the electrical wiring of this appliance. If the control power wiring is damaged or deteriorated then it must be replaced by an authorized person. Failure to do so may result in electric shock, fire, serious injury or product failure.

Removal of the access covers of water heating system will expose 240V wiring and **MUST** Only be removed by an authorised person.

Care should be taken not to touch the pipe work as it may be **HOT!**

**DO NOT** place articles on or against this appliance.

**DO NOT** store chemicals or flammable materials near this appliance.

**DO NOT** operate with collectors or covers removed from this appliance.

**DO NOT** activate pump unless cylinder is full of water.

This appliance is not suitable for use as a domestic spa pool or swimming pool heater.

## NOTICE TO VICTORIAN CONSUMERS



This appliance **MUST BE** installed by a person licensed with the Victorian Building Authority.

**ONLY** a licensed person will have insurance protecting their workmanship.

So make sure you use a licensed person to install this appliance and ask for your Compliance Certificate.

For further information contact the Victorian Building Authority on 1300 815 127

**SAFETY**



This appliance is **NOT** intended for use by persons (including children) with reduced physical, sensory or mental capabilities, or lack of experience and knowledge unless they have been given supervision or instruction concerning use of the appliance by a person responsible for their safety.

Children should be supervised to ensure that they **DO NOT** play with the appliance.

**Hydrogen Gas**

If the hot water heater is not used for two weeks or more, a quantity of hydrogen gas, which is highly flammable, may accumulate in the water heater. To dissipate this safety, it is recommended that a non electrically operated hot tap be turned on for several minutes at a sink, or bath, but not a dishwasher or other appliance. During this procedure there must be no smoking, open flame or any electrical appliance operating nearby. If hydrogen gas is discharged through the tap, it will probably make a sound like air escaping.

**Water Temperature**

To meet regulatory requirements the temperature of stored water **MUST NOT** be less than 60°C. The thermostat on your water heater is factory pre-set to 70°C. The thermostat setting can be adjusted between 60°C and 70°C by an electrician or other suitably qualified trades person.



The thermostat setting must only be adjusted by an Electrician or other suitably qualified trades person.

The access cover to the element and thermostat must only be removed by an Electrician or other suitably qualified trades person.

**SCALD HAZARDS**



**Hot Water can cause scalds.**

**Children, disabled, and the elderly are at the highest risk of being scalded.**

**Feel water temperature before bathing or showering.**

**Scalds from hot water taps can result in severe injuries to young children.**

**Scalds can occur when children are exposed directly to hot water when they are placed into a bath which is too hot.**

**Always.....**

Test the temperature of the water with your elbow before placing your child in the bath, also carefully feel water before bathing or showering yourself.

Supervise children whenever they are in the bathroom.

Make sure that the hot water tap is turned off tightly.

**Consider.....**

Installing child proof tap covers or child resistant taps (both approaches will prevent a small hand being able to turn on the tap).

Installing tempering valves or thermostatic mixing valves which reduce the hot water temperature delivered to the taps. Your local plumbing authority may already require that these be fitted. Contact your installer or local plumbing authority if in doubt.

**Never....**

Leave a toddler in the care of another child. They may not understand the need to have the water temperature set at a safe level.



## SAFETY DEVICES

For safe operation this water heater is fitted with a combination Pressure & Temperature Relief Valve, a thermostat and an over-temperature cut out for each heating element.



**DO NOT tamper with or remove safety devices.**

**DO NOT operate this water heater unless all safety devices are fitted and in working order.**

The operation of the thermal cut out indicates a possibly dangerous situation. **DO NOT** reset the thermal cut out until the water heater has been serviced by a qualified person.

### Pressure & Temperature Relief (PTR) Valve

This valve is located near the top of the water heater and is essential for safe operation.



**DO NOT seal or block the outlet of the PTR valve or its drain pipe.**

**DO NOT** replace the PTR valve with one that has a higher pressure rating than is specified for the water heater.

The PTR valve should be checked for performance or replaced at intervals not exceeding 5 years, or more frequently in areas with a high incidence of water deposits by a qualified person. The easing gear must be operated at least once every six months or more frequently in areas with a high incidence of water deposits.



**Failure to do this may result in the water heater cylinder failing or under certain circumstances, exploding. Water discharged will be very hot. Exercise care to avoid scald injury. If the valve does not seal again when the easing gear is closed, contact Rinnai to arrange inspection by a qualified person.**

It is important you raise and lower the easing gear gently. If the valve does not discharge water when the easing gear lever is lifted, there may be a serious problem and the power supply in the meter box (the switch marked 'Water heater' or 'hot water') or the isolating switch installed near the water heater must be switched off immediately. Contact Rinnai to arrange inspection by a qualified person.

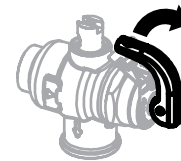

**Gently lift lever until water flows from drain line, lower lever gently to close**

It is normal for the PTR valve to release a small quantity of water through the drain pipe during heating. If the valve dribbles or leaks continuously, try easing the valve gear for a few seconds. This may dislodge any foreign matter and stop leakage. If leakage does not stop there may be a problem as detailed below:

- If there are heavy flows of water until the water heater is cold which then stops until the water reheats there may be a serious problem and the power supply in the meter box (the switch marked 'Water heater' or 'hot water') or the isolating switch installed near the water heater must be switched off immediately. Contact Rinnai to arrange inspection by a qualified person.
- If there is a steady flow for long periods, often at night, it may be as a result of the water pressure exceeding the design pressure of the water heater. Contact your installing plumber as a Pressure Limiting Valve (PLV) may be required.

### Expansion Control Valve (ECV)

An ECV is recommended in all geographical areas where the water supply has a tendency to cause scaling, including South Australia and Western Australia. Local regulatory authorities may require that an ECV be fitted. The ECV is to be supplied and fitted by the installer. Refer to the section Water Quality for more information on scaling water.

If an ECV is fitted, operate the easing gear at least once every six months to remove any deposits and to verify that it is not blocked.

The ECV should be checked for performance or replaced at intervals not exceeding 5 years, or more frequently in areas with a high incidence of water deposits by a qualified person.

It is normal and desirable that the ECV allows a small quantity of water to be discharged through the drain pipe during the heating cycle. If the valve dribbles or leaks continuously, operate the easing gear for a few seconds. This may dislodge any foreign matter and stop leakage. If leakage does not stop Contact Rinnai to arrange inspection by a qualified person.

# IMPORTANT INFORMATION

## ANODE

The water heater is fitted with a sacrificial anode to extend its life. It will slowly dissipate whilst protecting the cylinder. The life of the water heater may be extended by arranging for an authorised person to inspect the anode and replace it if required. It is recommended that the anode be inspected at least every 5 years. The factory fitted Rinnai anode is Magnesium based. This anode is suitable when the total dissolved solids (TDS) content in the water supply does not exceed 600 mg/L, which is the case in most areas. In areas where the total dissolved solids (TDS) content in the water supply exceeds 600 mg/L the Rinnai aluminium based anode is required.

## WATER QUALITY

The water quality of most public supplies is suitable for the water heating system. The water quality from bore wells is generally unsuitable for the water heating system. Refer to the 'Warranty Conditions' for water quality parameters and how they affect the warranty conditions. If in doubt about the water quality, have it checked against the parameters listed in the warranty conditions. If sludge or foreign matter is present in the water supply, a suitable strainer filter should be incorporated in the water supply to the system.

## OPERATIONAL OVERVIEW (How the hot water system works)

**Single Element Model:** A vitreous enamel lined steel cylinder stores water which is heated by a single thermostatically controlled heating element, located at the base of the cylinder. The water heater connects directly to the mains water supply. The heating element can be connected to a Continuous or Off-Peak electricity supply. The continuous supply is appropriate when the water heater capacity is less than the daily usage of hot water. The Off-Peak supply is appropriate when the water heater capacity exceeds the daily usage of hot water. The Off-Peak supply allows heating only for set periods and a volume of water sufficient for daily usage is heated during the set period and stored. The Off-Peak supply is usually cheaper. Electricity supply types and tariffs vary according to the local electricity authority.

**Twin Element Model:** A vitreous enamel lined steel cylinder stores water which is heated by a twin thermostatically controlled heating elements, one element is located at the base of the cylinder, while the other is located near the top. The water heater connects directly to the mains water supply. The bottom heating element heats the whole contents of cylinder and Top heating element (booster) only operates during the high demand periods to heat the upper portion of the contents of the cylinder. The two heating elements are wired for non-simultaneous operation, so that only one heating element can operate at a time. The bottom heating element can be connected to an Off-Peak electricity supply, and the top heating element to a continuous electricity supply.

## Turning Water Heating System 'OFF'

If the water heater is not going to be used for only a few days, we suggest you leave it switched on. If it is necessary to switch off the water heater, the switch is usually marked and located in the electricity meter box of the building.

## Turning Water Heating System 'ON'

Switch on the electric supply to the heating elements. The switch is usually marked and located in the electricity meter box of the building. Water heating will now occur as required. It may take a number of hours before hot water is available.

## DRAINING



Draining **MUST BE** carried out by a qualified person.

Water may be **HOT** during draining.

Drain the water heater as follows:

1. Isolate or turn 'OFF' the water heater at the electricity supply.
2. Close the cold water isolation valve at the inlet to the water heater.
3. Close all hot water taps.
4. Operate the PTR valve easing gear - gently. Operating the PTR valve easing gear will relieve the pressure in the water heater.
5. Undo the cold water inlet union. Attach a hose to the water heater side of the union. Let the other end of the hose go to a drain.
6. Operate the PTR valve easing gear again. This allows air into the water heater and will result in water draining through the hose.

# CARE & MAINTENANCE

## SAVE A SERVICE CALL

Check the items below before requesting a service. Service and parts charges may be incurred where it is found that there is no fault with the water heater and the issue is related to the plumbing installation or is due to the failure of water or electric supplies.

Insufficient or no hot water	
Is the electricity supply connected?	Check that the isolating switch marked "HOT WATER" or "WATER HEATER" at the meter box is switched on. Check also that any isolating switches installed near the water heater are switched on.
	Check the fuse or circuit breaker marked "HOT WATER" or "WATER HEATER" at the meter box. Repeated failure of fuse or tripping of circuit breaker indicates a fault which must be investigated by an authorised trades person.
Is your unit a Twin Element electric water heater?	A twin element model (non-simultaneous) must have a continuous electricity supply to the top heating element. Check that this is the case.
Are you using more hot water than you think?	Often it is not realized how much hot water is actually used. This applies especially to showering. Review hot water usage, especially the time taken for showering, and investigate the use of flow control valves or Water saving shower roses.
Are water heater valves discharging excessively?	Refer to the section "Safety Devices" on page 7.
Thermostat settings?	Check the temperature of hot water delivered with a thermometer placed under the closest outlet (usually the kitchen sink) on a non-tempered hot water line. This test should be done early in the morning after overnight electrical boosting before any hot water is used. The temperature of the water delivered should be at least 55°C (allowing for heat losses in pipe work). If this is not the case, the temperature may need to be increased. Contact your installer or Rinnai to discuss adjusting the thermostat.
No water from the hot tap?	Restriction in the hot tap or failure of the cold water supply to the heater. Check for water flow at the other hot taps and that the cold water isolation valve is fully open.

High Electricity Bills	
If you think your electricity bill is too high, check for these possibilities. <i>If, after investigating, and you still require assistance contact Rinnai.</i>	You may be using more hot water than you think. This applies especially to showering. Review hot water usage, especially the time taken for showering, and investigate the use of flow control valves or 'water saving' shower roses. Investigate recent changes to hot water usage patterns.
	Water heater valves may be discharging excessively. Refer to the section "Safety Devices" on page 7.
	There may be hot water leakages in hot water pipes or taps. Have these checked and rectified by a plumber.
	There may have been changes in electricity tariffs since your last bill.

## PERIODIC MAINTENANCE & SERVICING

If overflow tray and drain are fitted, it is the users responsibility to have these checked periodically to ensure there are no blockages.

The user should operate the easing gear of the ECV and PTR valve (if fitted) every 6 months as described under "Safety Devices" on page 7.

Rinnai service network personnel are fully trained and equipped. If your Rinnai appliance requires servicing contact Rinnai as per the details on the back page of this manual. Rinnai recommends that this commercial appliance be inspected and serviced by a qualified person every 12 months.

The ECV and PTR valve **MUST BE** checked for performance or replaced by a qualified person at intervals not exceeding 5 years or more frequently in areas where the water is classified as scaling water. Refer to both the "Anode" and "Water Quality" on page 8 for Anode selection, inspection and maintenance requirements).

If the electric supply conduit to the water heater is damaged, it **MUST BE** replaced by a qualified person in order to avoid a hazard.

# SPECIFICATIONS

## APPLIANCE COMPONENTS

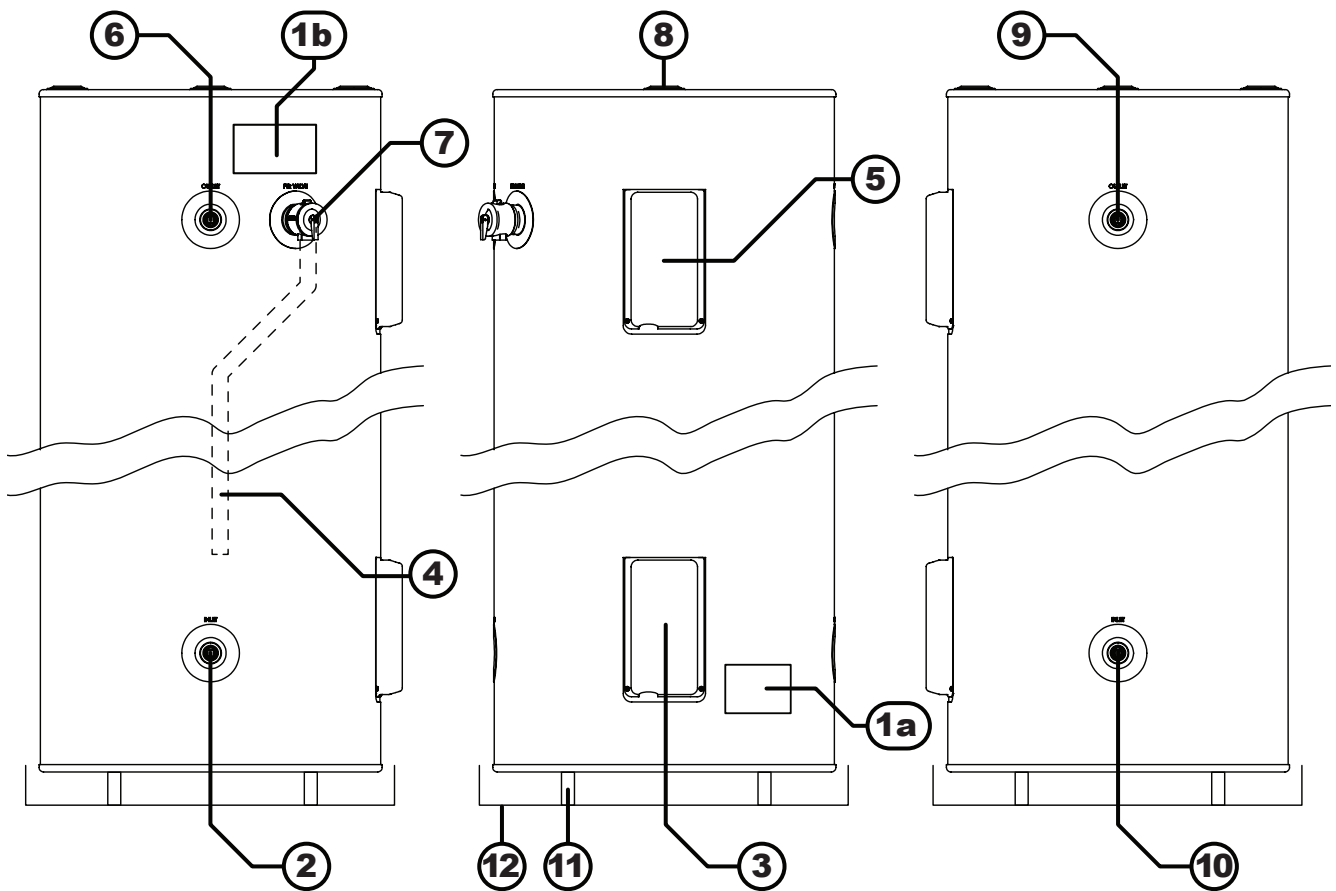

1. Data / Warning labels
2. Left hand cold water inlet  
*Connection RP 3/4" (20mm)*
3. Element / thermostat / electrical supply connection cover \*
4. PTR valve drain pipe  
*Copper only drain in accordance with AS/NZS 3500.4*
5. Element / thermostat cover (*Twin element models only*) \*
6. Left hand hot water outlet  
*Connection RP 3/4" (20mm), use a union connection and insulate hot water pipe*
7. PTR valve connection  
*RP 1/2" (15mm), use supplied PTR Valve*
8. Anode cap
9. Right hand (duplicate) hot water outlet  
*Connection RP 3/4" (20mm), use a union connection and insulate hot water pipe*
10. Right hand (duplicate) cold water inlet
11. Water heater support  
*In accordance with AS/NZS 3500.4*
12. Safe Tray & drain  
*Where required, in accordance with AS/NZS 3500.4*



\* Removal and connection by qualified persons **ONLY**, in accordance with AS/NZS 3000

Valves with pressure ratings other than specified are unsuitable and **MUST NOT** be used.

**WATER HEATER** - located closest to most frequently used outlet - Access for service in the installed position.

**TABLE 1. DIMENSIONS & WEIGHT**

Models	EHFD 160	EFHA 250	EHFA 315
A	1313	1484	1770
B	600	674	674
C	537	605	605
D	1107	1248	1541
E	186	210	210
F	110	135	135
G	n/a	985	1225
Weight (kg)	51	71	91

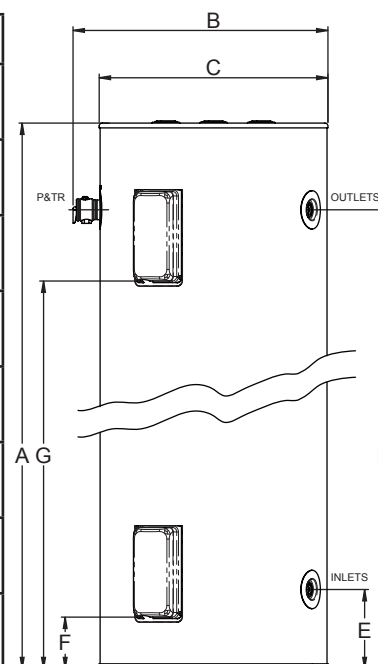

All dimensions are in mm unless otherwise stated

**TABLE 2. RATINGS & OTHER SPECIFICATIONS**

Models		EHFD 160	EFHA 250	EHFA 315				
Cylinder Rated Pressure (kPa)		1000	1000	1000				
PTR Rated Pressure (kPa)		1000	1000	1000				
ECV Rated Pressure (kPa)		850	850	850				
ECV Fitted (kPa)	Fit PLV if mains pressure exceeds	680	680	680				
	Recommended PLV pressure rating	500	500	500				
ECV Not Fitted (kPa)	Fit PLV if mains pressure exceeds	800	800	800				
	Recommended PLV pressure rating	500	500	500				
Rated Capacity Hot Water Litres (l)		160	250	315				
Heating Element (W)	Lower	2400	3600	2400	3600	4800	3600	4800
	Upper	n/a		n/a		3600	4800	3600
Inlet/Outlet Connections		3/4" (20 mm)						



**A PLV is not supplied with these models. A PLV **MUST BE** fitted if the Mains Pressure exceeds the limits shown. If the mains pressure is within the limits shown fitment of the PLV is optional. However, it is recommended that the PLV is fitted in all installations as it aids water and energy conservation.**



# INSTALLATION METHODS

## HOT WATER PLUMBING SYSTEM EXAMPLE - NO TLD

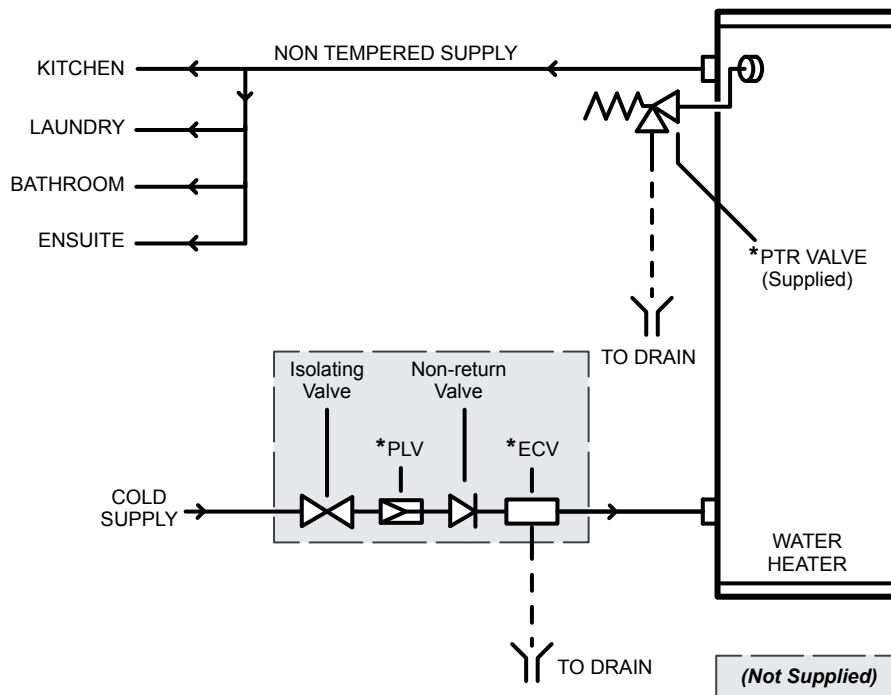

Valves with pressure ratings other than specified are unsuitable and **MUST NOT** be used.  
 \*For ratings see "Table 2. Ratings & Other Specifications" on page 11.

## HOT WATER PLUMBING SYSTEM EXAMPLE - WITH TLD

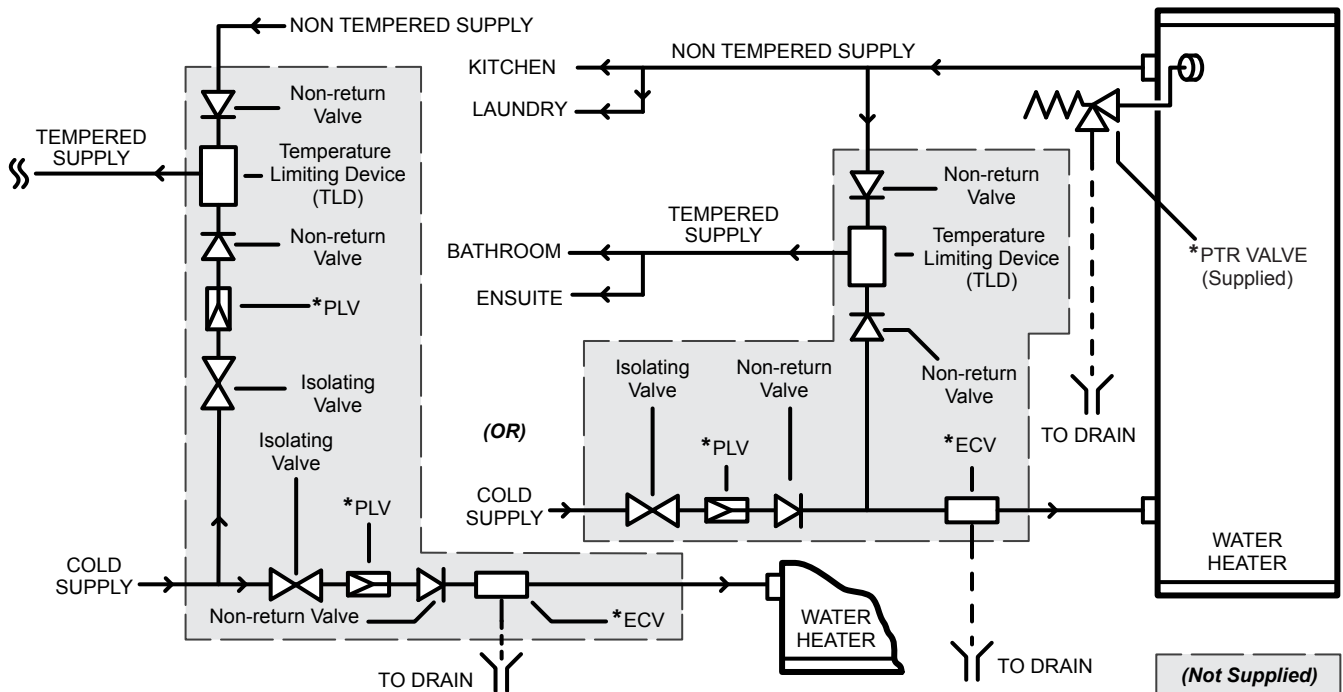

Valves with pressure ratings other than specified are unsuitable and **MUST NOT** be used.  
 \*For ratings see "Table 2. Ratings & Other Specifications" on page 11.

It may be a requirement that the hot and cold water supply pressures to a Temperature Limiting Device (TLD) are equal. If this is the case, a PLV with the same pressure rating as the PLV for the hot water is required for the TLD as shown.



**HOT WATER PLUMBING SYSTEM EXAMPLE / FLOW & RETURN PIPE WORK - NO TLD**

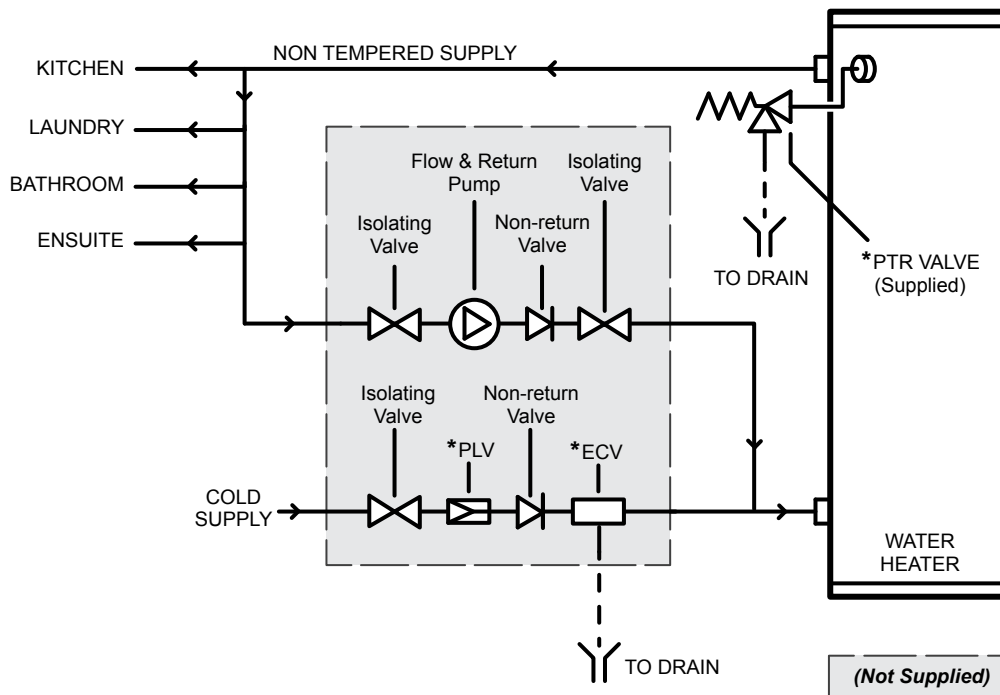

Valves with pressure ratings other than specified are unsuitable and **MUST NOT** be used.  
 \*For ratings see "Table 2. Ratings & Other Specifications" on page 11.

**HOT WATER PLUMBING SYSTEM EXAMPLE / FLOW & RETURN PIPE WORK - WITH TLD**

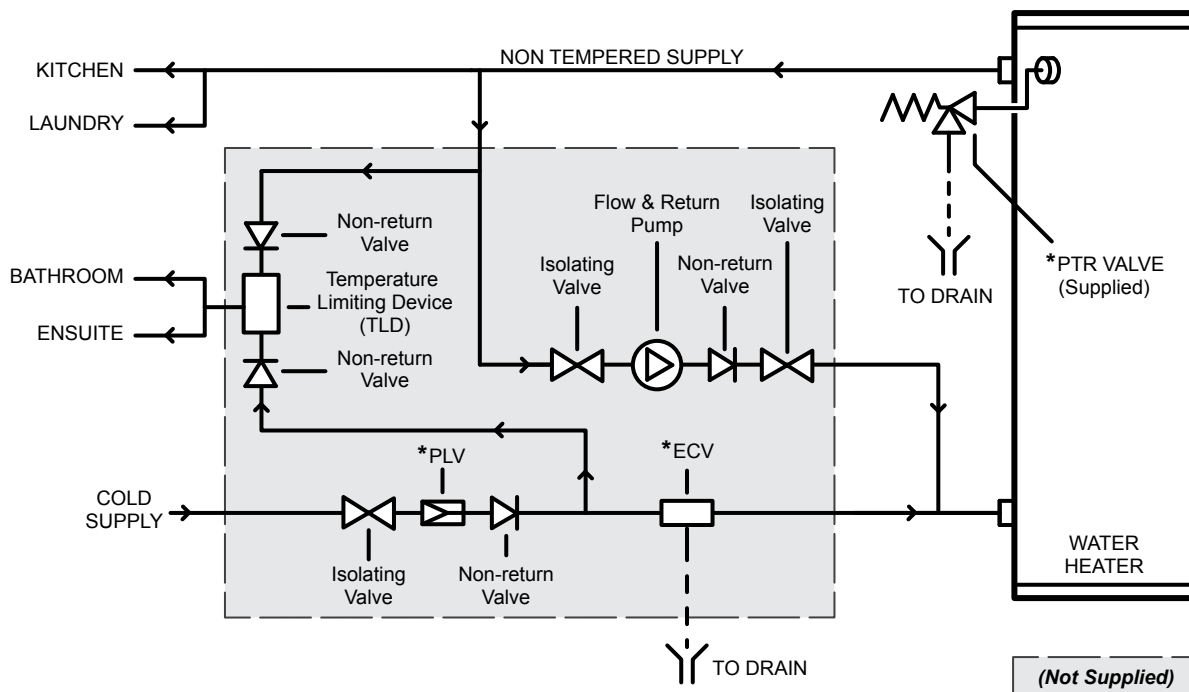

Valves with pressure ratings other than specified are unsuitable and **MUST NOT** be used.  
 \*For ratings see "Table 2. Ratings & Other Specifications" on page 11.

1. This schematic is an example only, variations may also be suitable.
2. Tempered water from a TLD **CANNOT** be re-circulated. The TLD **MUST BE** positioned in a dead leg, branching off the circulated hot water flow and return pipe.



# INSTALLATION

This appliance **MUST BE** installed by a qualified person in accordance with:

- Manufacturers installation instructions
- Current AS/NZS 3000 Wiring Rules
- Current AS/NZS 3500.4 Plumbing and Drainage - Heated Water Services
- All local regulatory requirements

This appliance is **NOT** suitable for use as a spa or swimming pool heater.

## LOCATION

The Rinnai Hotflo (EHFA/EHFD) storage water heater range have an ingress protection rating of IPX4 making them suitable for internal or external installation.

The water heater should be placed as close as practicable to the most frequently used hot water outlet point or points to minimize the delay time for hot water delivery. This will usually be the kitchen tap. For installations where the distance between the water heater and the outlets is considerable, a flow and return system can be used which will minimize the waiting time for hot water delivery.

It is recommended that the water heater is installed at ground or floor level. It **MUST BE** installed in a vertically upright position. The water heater **MUST BE** accessible without the use of a ladder or scaffold. Installation into roof spaces **MUST** comply with local regulatory authority requirements.

Ensure the PTR valve, isolating valves, access covers, thermostats and heating elements have sufficient clearances and are accessible for service and removal. The information on the rating plates **MUST** also be readable.

The water heater **MUST BE** installed in free standing mode on a level and stable base in a manner that is acceptable to local authorities. Avoid situations that may result in pooling of water around the base of the water heater.

Where property damage can occur as a result of water leakage, the water heater **MUST BE** installed with a safe tray (overflow tray) and drain. Construction, installation and draining of the safe tray **MUST** comply with local regulatory requirements and. AS/NZS 3500.4 also requires the use of a safe tray for particular situations.

## WATER QUALITY

The water quality of most public supplies is suitable for the water heater. Water quality from bore wells is generally unsuitable. Refer to the 'Warranty Conditions' for water quality parameters and how they affect warranty. If in doubt about water quality, have it checked against the parameters listed in the warranty conditions.

If sludge or foreign matter is present in the water supply, a suitable strainer or filter should be incorporated in the water supply to the water heater.

Scaling water is defined as having a total hardness in excess of 200 mg/litre (expressed as calcium carbonate) or a Saturation Index in excess of +0.4. Areas that have a scaling water supply include South Australia and Western Australia. In a scaling water supply, calcium carbonate and possibly other compounds are deposited out of the water onto any hot metallic surfaces and form a scale.

In areas of scaling water an ECV **MUST BE** fitted on the cold water line between the non-return valve and the connection to the water heater to protect the PTR valve and the water heater. Local regulatory authorities may require that an ECV be fitted. The ECV is to be supplied and fitted by the installer.

## MAINS PRESSURE

The Hotflo (EHFA/EHFD) electric storage water heater range utilise mains pressure by connecting directly to the mains water supply. If the mains water supply pressure in your area exceeds the rated pressure of the water heater a PLV **MUST BE** fitted.

The mains water supply pressure should be greater than 350kPa for true mains pressure operational performance to be achieved.

## THERMOSTAT SETTING

The thermostat setting can be adjusted between 60°C and 70°C. It has been factory pre-set to 70°C.



The thermostat settings **MUST ONLY** be adjusted by a qualified person.

## REDUCING THE RISK OF SCALDING

This water heater can deliver water at temperatures which can cause scalding. Children, disabled and the elderly are at the highest risk of being scalded.

Local regulatory requirements and the requirements of AS/NZS 3500.4 **MUST BE** considered regarding temperature limitations of hot water delivered to areas used primarily for personal hygiene such as bathrooms and ensuites. The delivery temperature may be limited to 45°C for early childhood centres, primary and secondary schools and nursing homes or similar facilities for the young, aged, sick or people with disabilities and 50°C for all other buildings. These temperatures will reduce the risk of scald injury and can be achieved by the use of a TLD, for example a thermostatic mixing valve or tempering valve.

Rinnai recommend that an approved TLD is fitted into the hot water pipe work from the water heater to areas used primarily for personal hygiene such as bathrooms and ensuites to reduce the risk of scalding.

Refer to the installation configurations "Hot Water Plumbing System Example - With TLD" on page 12 and "Hot Water Plumbing System Example / Flow & Return Pipe Work - With TLD" on page 13.

## PLUMBING CONNECTIONS

### Connections to the water heater

Refer to Specifications for the plumbing connection sizes and location (Table 1) and the specified pressure ratings of valves (Table 2). Refer also to the diagrams under "Installation Configurations".



Valves with pressure ratings other than specified **MUST NOT** be used.

An isolation valve and non-return valve **MUST BE** fitted in the cold water supply to the water heater so the water heater can be isolated. Combination isolation and non-return valve such as 'Duo' or 'Trio' valves are suitable for this purpose.

Isolation valves **MUST NOT** be fitted directly to the appliance. Use disconnection unions between the water heater and the valves to allow the water heater to be disconnected from pipework at a later date.

Purge pipework to remove swarf and other foreign matter before final connection to the water heater to avoid damage to the water heater.

If olive compression fittings are used for connections the olives **MUST BE** metallic such as brass or copper. Only approved thread sealing tape or sealant should be used.

### Water Pipes

Pipe sizing should be carried out by persons competent to do so for each individual installation in accordance with local regulatory requirements and take into consideration the specifications of the water heater.

The cold supply pipe to and hot water pipe from the water heater **MUST BE** insulated in accordance with local regulatory requirements and AS/NZS 3500.4 to optimise performance and energy efficiency. Insulation **MUST BE** weatherproof and UV resistant if exposed.

The hot water pipe from the outlet of the water heater should also be configured in the shape of a "heat trap" to aid energy efficiency in accordance with local regulatory requirements and AS/NZS3500.4.

To prevent damage to the water heater when attaching pipe clips or saddles to the jacket, it is recommended that self drilling screws with a maximum length of 12mm are used. If drilling is required take extreme care **NOT** to penetrate the inner cylinder. Damage to the inner cylinder is **NOT** covered under warranty.

### **Pressure and Temperature Relief (PTR) Valve**

A combination PTR valve is supplied with the water heater. It is an important safety device and **MUST BE** fitted in all installations before the water heater is operated.

**DO NOT** use the valve if the sensing probe has been bent or it is damaged in some other way.

The PTR valve is to be screwed to the connection marked "PTR Valve" at the top of the water heater.

The thread **MUST BE** sealed with an approved sealing tape. Make sure the sealing tape does **NOT** hang over the end of the thread of the valve as this may block the waterway and prevent the valve from operating properly.

To screw the valve into the water heater connection use a wrench on the spanner flats and **NOT** the valve body. Leave the valve outlet pointing downwards. A copper drain pipe **MUST BE** fitted to the valve outlet in accordance with the section "Relief Valve Drain Lines" on the bottom of page 16.

The valve body **MUST BE** insulated in accordance with local regulatory requirements and AS/NZS 3500.4 to optimise performance and energy efficiency. Insulation **MUST BE** applied in a manner that ensures it does **NOT** interfere with the operation of the valve. Insulation material **MUST BE** weatherproof and UV resistant if exposed.

### **Expansion Control Valve (ECV)**

In areas of scaling water an ECV **MUST BE** fitted on the cold water line between the non-return valve and the connection to the water heater to protect the PTR valve and the water heater, as per the diagrams under "Installation Configurations". It **MUST BE** the last valve on the cold inlet before the water heater.

Local regulatory authorities may require that an ECV be fitted. The ECV is to be supplied and fitted by the installer.

Refer to the section Water Quality for more information on scaling water.

A copper drain pipe **MUST BE** fitted to the valve outlet in accordance with the section "Relief Valve Drain Lines" on the bottom of page 16.

The valve body **MUST BE** insulated in accordance with local regulatory requirements and AS/NZS 3500.4 to optimise performance and energy efficiency. Insulation **MUST BE** applied in a manner that ensures it does **NOT** interfere with the operation of the valve. Insulation material **MUST BE** weatherproof and UV resistant if exposed.

### **Pressure Limiting Valve (PLV)**

A PLV is to be fitted if the supply pressure exceeds the limits shown in Table 2 "Ratings & Other Specifications" on page 11 as per the diagrams under "Installation Configurations". The PLV is to be supplied and fitted by the installer.

### **Relief Valve Drain Lines**

Copper drain lines of size DN15 **MUST BE** fitted to the ECV (if fitted) and the PTR valve. Use disconnection unions to connect drain lines to the valves.

The configuration of drain lines **MUST BE** in accordance with local regulatory requirements and the requirements of AS/NZS3500.4.

The length should be as short as possible on a continuous downward slope with no restrictions. Length should **NOT** exceed 9 metres with no more than three 45° bends. If a drain line discharges into a tundish, the drain line from the tundish **MUST NOT** be less than DN20. The drain line from a tundish **MUST** meet the same requirements as drain lines from relief valves.

The drain lines from the PTR valve and ECV (if fitted) from an individual water heater may be interconnected subject to local regulatory authority requirements and AS/NZS3500.4. The termination point **MUST** also comply with local regulatory requirements and AS/NZS3500.4. Drain lines **MUST NOT** discharge into a safe tray.

The outlet of drain lines **MUST NOT** be obstructed and be positioned so that they are readily discernible but **NOT** cause injury, damage or nuisance.

In areas where water pipes are prone to freezing, drain lines **MUST BE** insulated and **NOT** exceed 300mm in length. In this case the drain line **MUST** discharge into a tundish through an air gap of between 75mm and 150 mm.



## HAZARDOUS VOLTAGE. Risk of Electrical Shock.



Isolate all  
sources of supply  
prior to servicing



### ELECTRICAL SUPPLY



Must be installed, maintained and removed by authorised persons in accordance with AS/NZS 3000 and all other relevant local regulations and municipal building codes including OH&S requirements.

Ensure electric wiring is installed properly. Improper installation may cause malfunction, fire, or electric shock.

The unit must be earthed following local electrical codes.

A water heater **NOT** fitted with a power cord & plug **MUST** have the heating element connected to an independent, fused, AC 240V 50 Hz power supply with an isolating switch installed at the switch board, which shall effectively isolate all active supply conductors from the circuit and means for disconnection must be incorporated in the fixed wiring in accordance with the wiring rules.

Ensure the premises wiring to the system is capable of withstanding the system electrical load (refer to Specifications - Table 1 for electrical load details).

The power supply to a single element model can be Off-Peak (overnight), Extended Off-Peak (overnight and day), or Continuous (day).

The power supply to a twin element model should be Off-Peak (overnight) to bottom heating element and Continuous to the top heating element.

Check the available tariffs with the local electricity supplier. The Off-Peak (overnight) is usually the most economical for the customer.

### Electrical Connections



The water heater **MUST BE** filled with water prior to connection to the power supply.



Electrical connection **MUST BE** carried out by a qualified person and in accordance with AS/NZS 3000 'Wiring Rules' and local authority requirements

Disconnect all power prior to installation and commissioning. This appliance is designed for single phase 240 Volts, AC mains electrical operation.

All electrical connections **MUST BE** made by an authorised person and must comply with all local electrical supply regulations and AS/NZS 3000.



The premises wiring to the heater must be capable of withstanding the appliance load.

Electrical access is via a 20 mm hole beneath the element cover for mounting with an approved weatherproof electrical conduit nipple. For entry to the element cover remove the two fixing screws.

Connect all ACTIVE and NEUTRAL wires in accordance with the wiring diagram which is also included at the rear of the element access cover. Ensure the incoming EARTH wire is securely fixed to the earth post provided on the heater case. Inspect and ensure that all wiring links are secure prior to fixing the access cover and turning the POWER ON.

To ensure the Over-temperature and Energy Cut-out is set, press the (red) 'reset' button on the Thermostat.

Wiring Diagrams

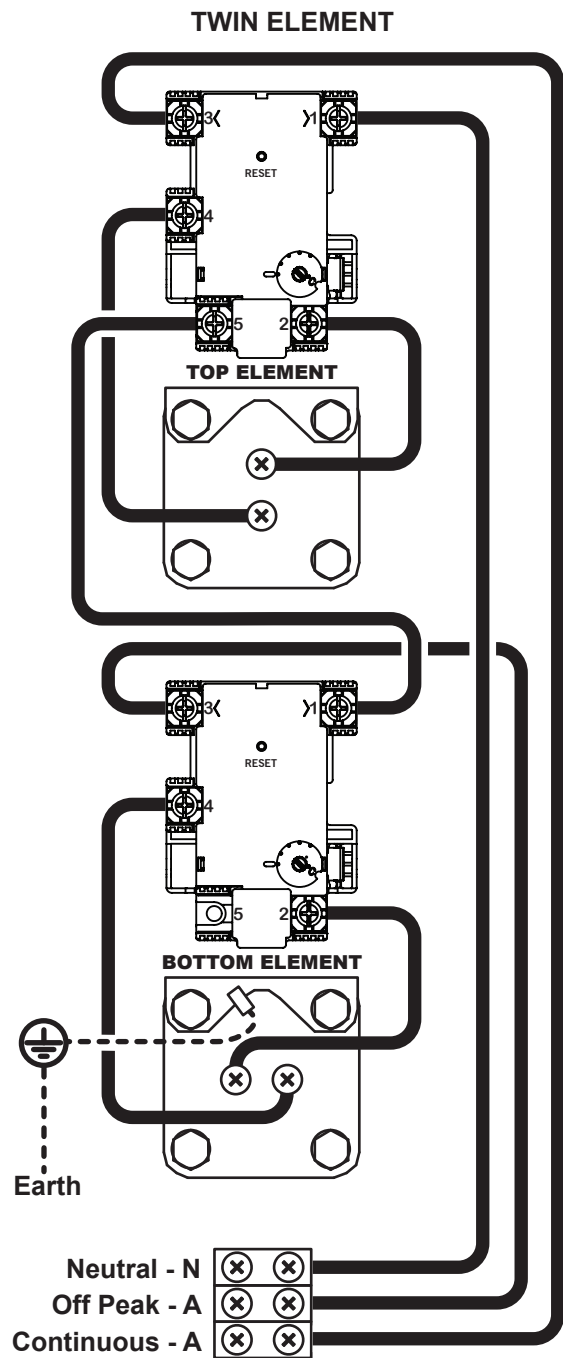
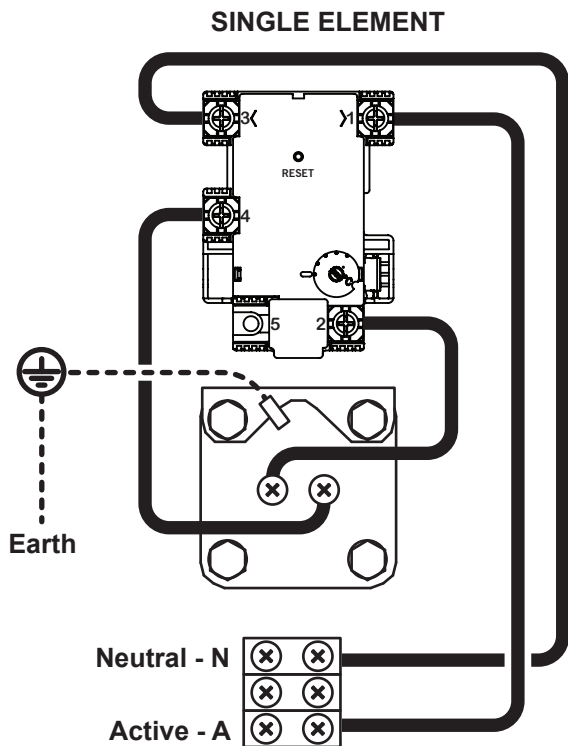

**Thermostat Setting**

The thermostat is adjustable from 60°C to 70°C. Turning the adjustment knob anticlockwise decreases the temperature setting and turning it clockwise increases the temperature setting. The water heater as delivered will have the thermostat preset to 70°C.



Ensure the power supply is switched **OFF** before removing the access cover to the element and thermostat.

The access cover to the element and thermostat **MUST ONLY BE** removed by an Electrician or other suitably qualified trades person.

The thermostat setting **MUST ONLY BE** adjusted by an electrician or other suitably qualified trades person.

After adjustment, press the (red) 'Reset' Button on the thermostats to ensure the over-temperature and energy cut-out is set.





Commissioning activities **MUST BE** carried out by an authorised person.

**DO NOT** switch on the electric power supply until the water heater is filled completely with water.

## **TO FILL & TURN 'ON' THE WATER HEATER**

1. Open all hot water taps in the building, including the shower.
2. Open the cold water isolation valve to water heater. Air will now be forced out of the taps.
3. Close each tap when water runs freely without air bubbles.
4. Check all plumbing connections and pipe work for water leaks.
5. Connect the water heater to the electricity supply, and turn the electric power supply 'ON'.

## **TO TURN 'OFF' THE WATER HEATER**

It may be necessary to turn off a water heater after installation and commissioning, for example during building activities or if the premises are vacant.

1. Isolate or turn 'OFF' the water heater at the electricity supply.
2. Close the cold water isolation valve at the inlet to the water heater.

# Rinnai

**Rinnai Australia Pty. Ltd.** ABN 74 005 138 769

## Head Office

100 Atlantic Drive,  
Keysborough VIC 3173

P.O. Box 460  
Braeside, Victoria 3195

Rinnai has a Service and Spare Parts network with personnel who are fully trained and equipped to give the best service on your Rinnai appliance. If your appliance requires service, please call our National Help Line. Rinnai recommends that this appliance be serviced every year.

**Product Sales and Service - National**  
Phone: 1300 555 545\* Fax: 1300 555 655\*  
**Technical Helpline and Spare Parts**  
National (Mon-Fri 8am - 5.30pm EST)  
Phone: 1300 555 545\* Fax: 1300 300 141\*  
*\*Cost of a local call higher from mobile or public phones.*

E-mail: [enquiry@rinnai.com.au](mailto:enquiry@rinnai.com.au)

For further information visit: [www.rinnai.com.au](http://www.rinnai.com.au)

