

Sears
owner's
manual

MODEL NO.
636.795454

CAUTION:
Read Rules for
Safe Operation
and Instructions
Carefully

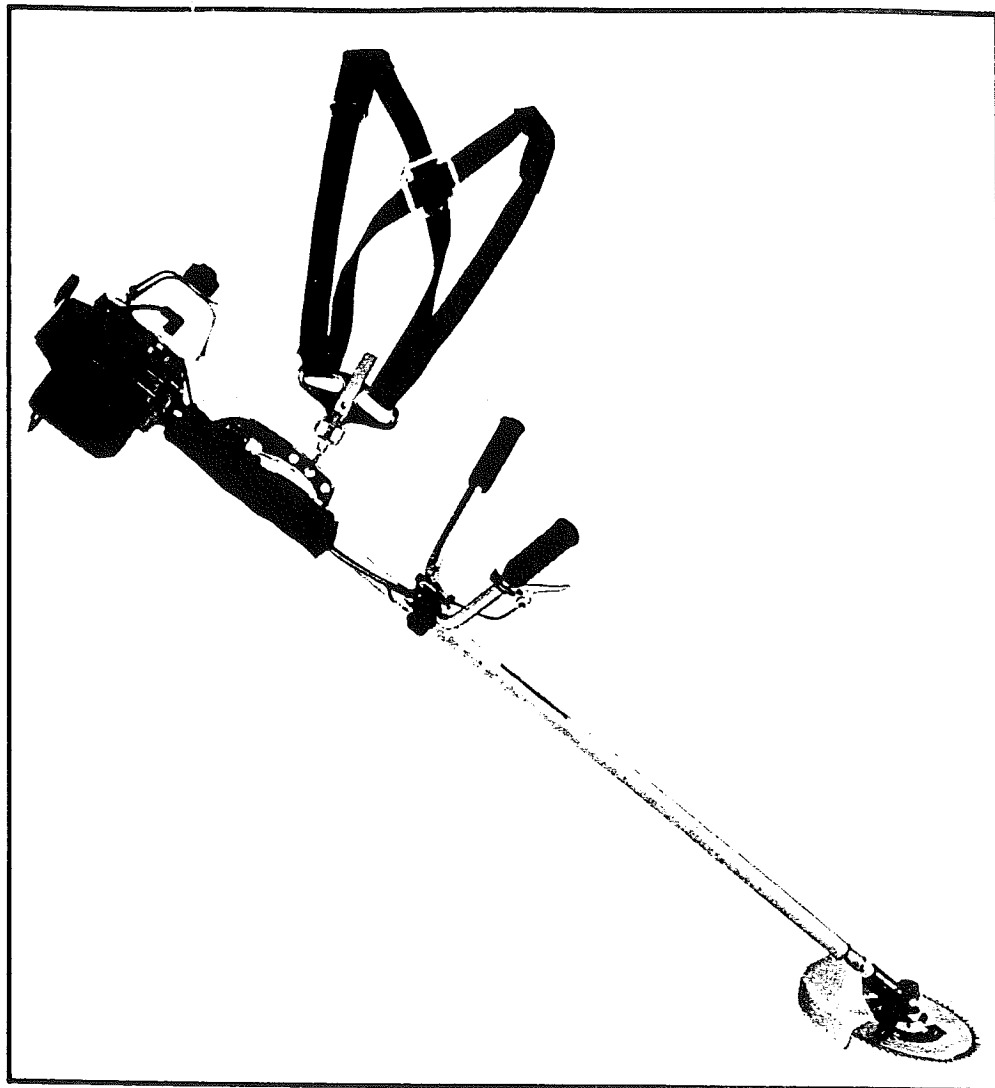

CRAFTSMAN

37.7 cc GAS BRUSHWACKER^{T.M.}

- Assembly
- Maintenance
- Operation
- Repair Parts

Sears, Roebuck and Co., Chicago, Ill. 60684 U.S.A.

**FULL 1 YEAR WARRANTY ON CRAFTSMAN
BRUSHWACKER™. 636. 795454**

If this CRAFTSMAN GAS BRUSHWACKER™. fails to perform properly, due to a defect in material or workmanship within one (1) year from date of purchase, Sears will repair it, free of charge.

If this GAS BRUSHWACKER™. is used for commercial or rental purposes, this warranty applies for only 90 days from date of purchase.

WARRANTY SERVICE IS AVAILABLE BY SIMPLY CONTACTING THE NEAREST SEARS STORE OR SERVICE CENTER, THROUGHOUT THE UNITED STATES.

This warranty gives you specific legal rights, and you may also have other rights which vary from state to state.

Sears, Roebuck & Co.
BSC 41-3
Sears Tower
Chicago, Illinois 60684

SAFETY RULES AND PRECAUTIONS

Proper safety precautions must be observed. Like all power equipment, this unit must be handled carefully. **DO NOT EXPOSE YOURSELF OR OTHERS TO DANGER.** Follow these simple rules:

1. Always wear safety goggles for eye protection. Dress properly, do not wear loose clothing or jewelry that could become caught in moving parts of the unit. Safe footwear should always be worn.
2. Inspect the entire machine for loose parts. (Nuts, bolts, screws, etc.)
3. **DO NOT USE** any attachment with this power head other than those manufactured by the manufacturer of the engine. Serious injury to the user or damage to the engine could result.
4. Keep the handles free of oil and fuel.
5. Always use the proper safety handle and hanging band when cutting.
6. Do not smoke while mixing fuel or filling the tank.
7. Do not mix fuel in an enclosed room or near open flames.
8. Always mix and store the fuel in a properly marked container that is approved for such usage.
9. Never remove the fuel tank cap while the engine is running.
10. Never start or run the engine inside a closed room or building. Fumes from the exhaust contain dangerous carbon monoxide.
11. Never attempt to make engine adjustments while the unit is running and strapped to the operator. Always make engine adjustments with the unit resting on a flat, clear surface.
12. Do not use the unit if it is damaged or poorly adjusted.
13. Inspect the area to be cut and remove all debris that could become entangled in the blade. Also remove any objects that the unit may sling during cutting.
14. Keep children away. Onlookers should be kept at a safe distance from the work area, at least 30 feet.
15. Do not use this unit for any job other than those for which it is intended as described in this manual.
16. Do not use this unit to cut or trim anything over waist high.
17. Do not overreach. Keep proper footing and balance at all times. Do not run unit standing on a ladder or any other unstable footing.
18. Keep hands and feet clear of the blade while unit is in use.
19. Do not run the unit at high speed when not cutting.
20. Do not use the unit when you are tired.
21. Maintain the unit with care. Always keep the blade sharp. Follow instructions for changing accessories.
22. Do not store in a closed area where fuel vapors can reach an open flame from hot water heaters, furnaces, etc.
23. Use only replacement parts that are identical to original equipment parts when servicing the unit. These parts are available from your dealer. The use of any other accessory or attachment may create a potential hazard.



CAUTION: The operation of any BRUSHWACKER™. Trimmer can result in foreign objects being thrown into the eyes, which can result in severe eye damage. Always wear safety glasses or eye shields before commencing power tool operation. We recommend Wide Vision Safety Mask for over spectacles or standard safety glasses, available at Sears Retail or Catalog Stores.

KNOW YOUR BRUSHWACKER™.

Your new BRUSHWACKER™ has been carefully packed at the factory to prevent damage during shipping and storage, however, even with the best of preventative measures, damage does sometimes occur. It is recommended that you follow the check out procedures listed below:

Remove all items from the carton, lay them out and check the parts to be sure that you have everything required for assembly. Also check carefully for any visible damage. (IN THE EVENT THAT SOMETHING IS DAMAGED OR MISSING OR BOTH, NOTIFY YOUR SEARS STORE IMMEDIATELY.)

You should familiarize yourself with the various parts of your BRUSHWACKER™ before attempting to assemble or operate the unit. Refer to drawing below.

SPECIFICATIONS

ENGINE TYPE:	2 Cycle Air Cooled	MUFFLER:	Lo Tone - w/Cover
DISPLACEMENT:	37.7 cc (2.30 Cu. In.)	CLUTCH:	Centrifugal
OPERATING RPM:	6000	FUEL TANK:	1 Liter (2.1 Pints)
IGNITION:	Solid State Ignition	SPARK PLUG:	STD 360942
CARBURETOR:	Horizontal Draft, Float Type	SPARK PLUG GAP:	.024" - .028"
STARTER:	Auto Rewind	LUBRICATION:	Fuel-Oil Mix Between 20 and 25 to 1
ON/OFF SWITCH	Toggle (positive "ON/OFF")	NOTICE:	For the first twenty hours, use the mixing ratio of Between 15 and 20 to 1

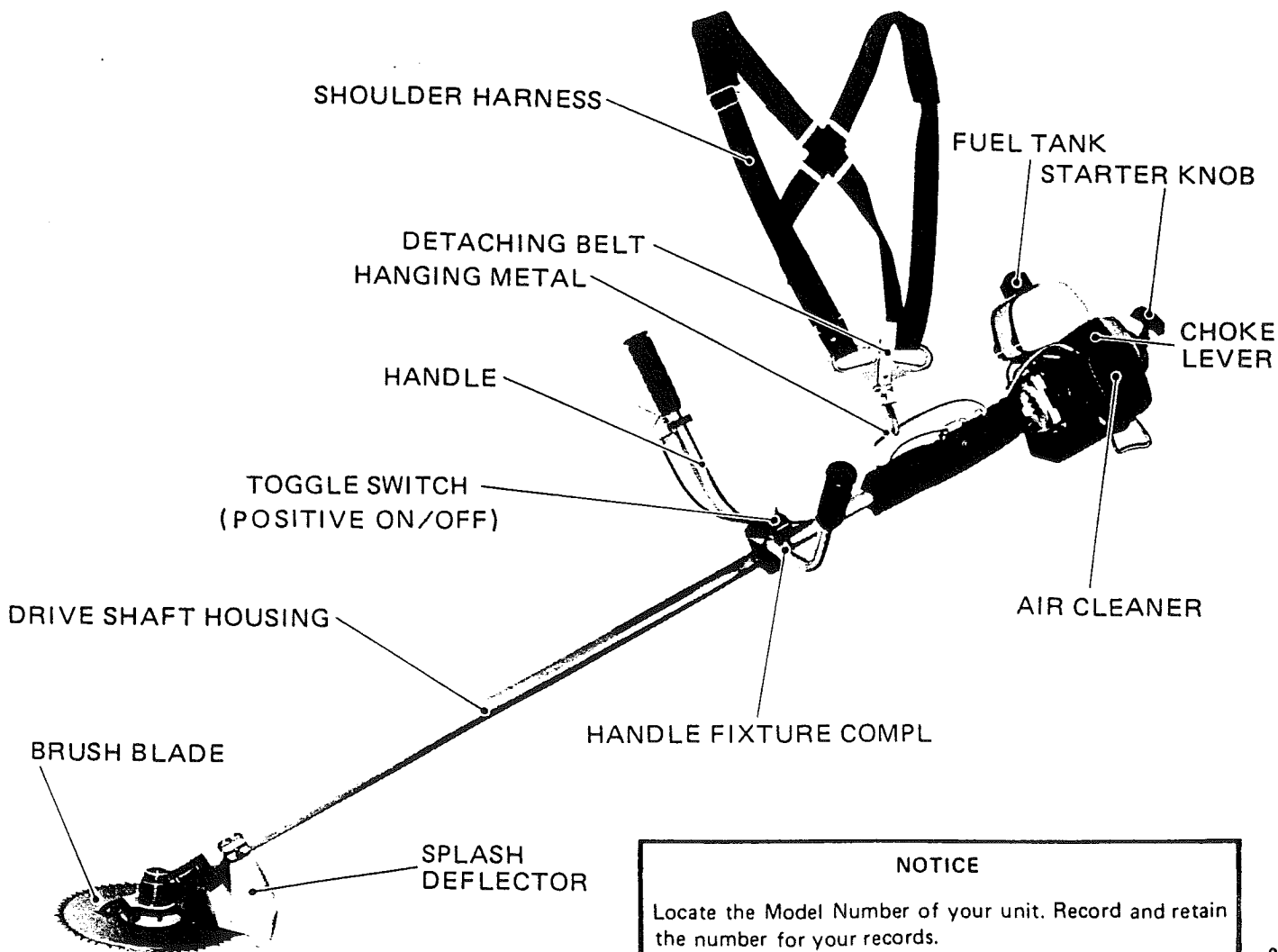

ASSEMBLY INSTRUCTIONS

1. After checking parts, fasten fuel tank and fit drive shaft to engine with four screws. Figure 1.

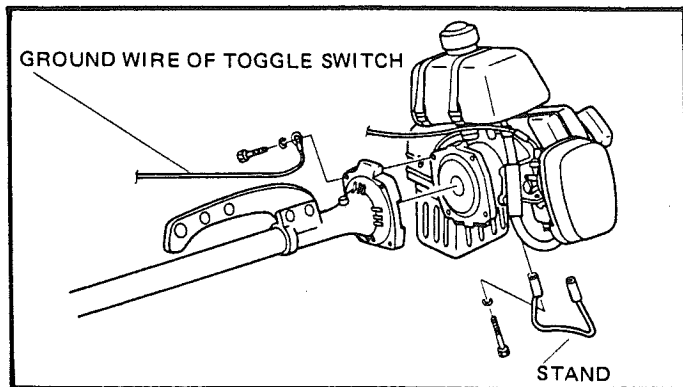

Figure 1

2. Attach stand to engine with two bolts. Figure 1.
3. Clamp the handle bar to the drive shaft. Connect the toggle switch cord with the cord coming from the ignition coil. Figure 2.

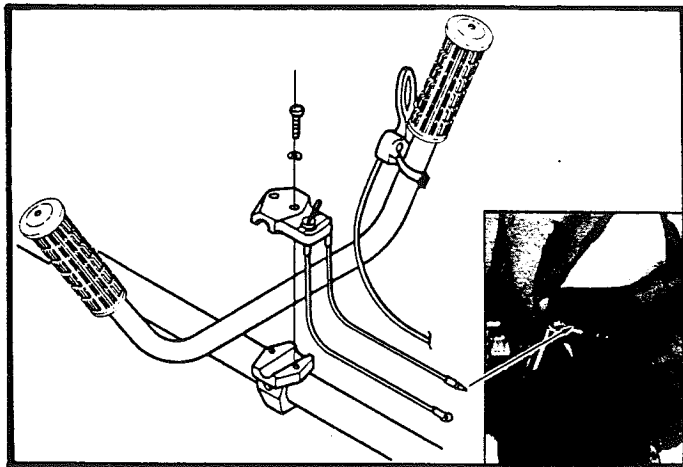

Figure 2

4. Wind the spiral tube round both the throttle wire and the toggle switch cord as in the figure. Attach waist pad. Figure 3.

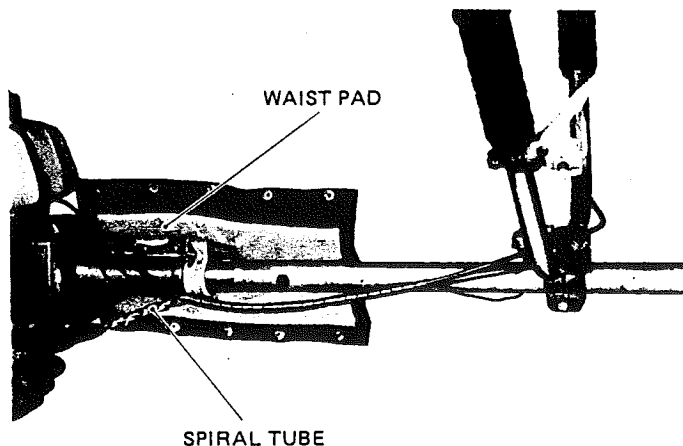

Figure 3

5. SPLASH DEFLECTOR ASSEMBLY

Attach the splash deflector unit to the Drive Shaft Housing using the clamp and screws provided. See figure 4.

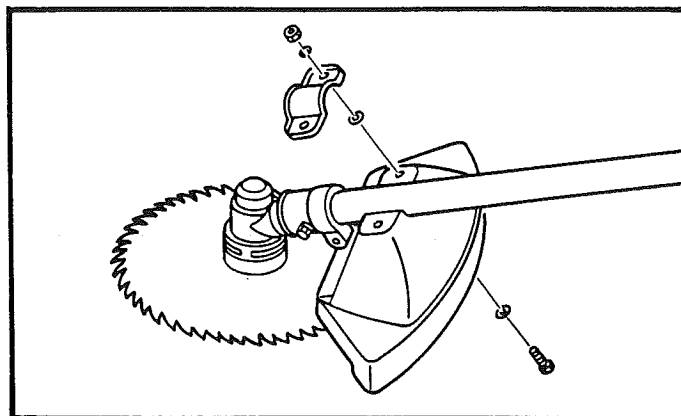

Figure 4

6. You are now ready to mount the blade and Arbor Lock on the end of the drive shaft. **CAUTION:** The teeth on the blade are very sharp. Wear gloves and be careful!

The arbor shaft and nut have left hand threads. Pay particular attention to blade rotation when installing the blade. Blade has counter-clockwise rotation when viewed from the engine end of the machine. When installing the blade, fasten the shaft with lock handle. Figure 5.

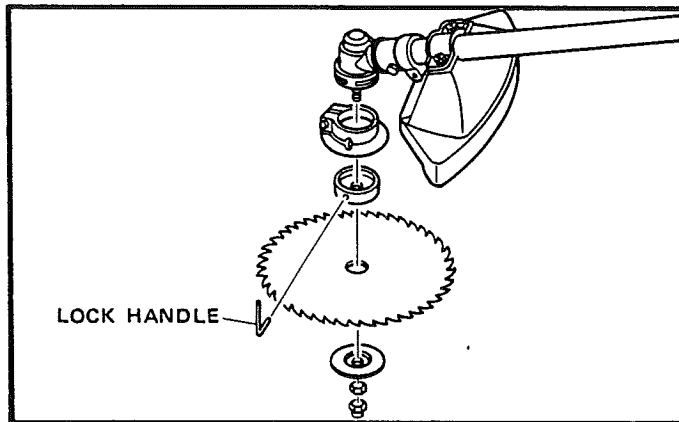

Figure 5

7. SHOULDER HARNESS

The SHOULDER HARNESS clips in one of the holes of the bracket as shown. Adjust so that the blade is parallel to the ground and you are comfortable. Figure 6.

WARNING! WARNING! WARNING!

The shoulder harness must be worn, the safety handle installed properly and both hands kept on the handles at all times while running this unit. Positive control is mandatory for safe operation. **DO NOT EDGE WITH THE METAL BLADE!** Keep blades sharp at all times. Splash deflector must be in place when using brush blades. For blade replacement, use only blades built for this unit. **DO NOT SUBSTITUTE.** Always shut unit off before disconnecting shoulder harness to examine blade. **BEFORE EACH USE,** examine the nuts which hold blade on to determine if they are tight.



Assembly Instructions (cont'd.)



Figure 6

Shoulder harness fitting procedure.

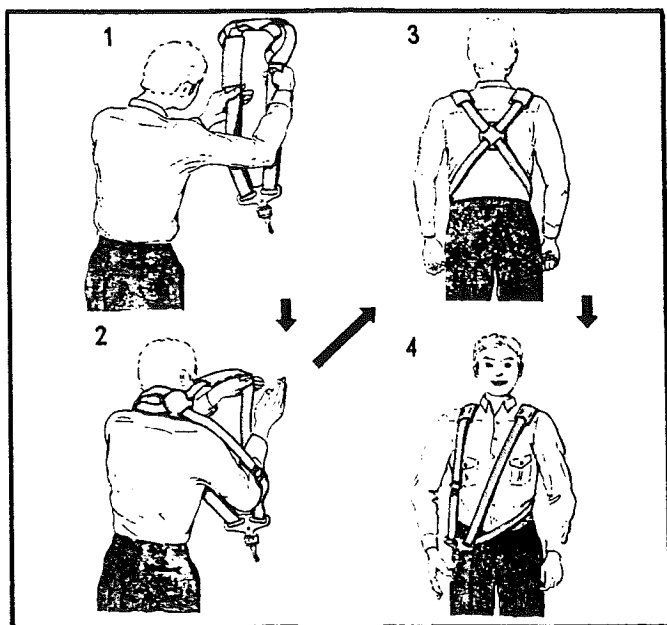

PREPARING FOR OPERATION

Fuel and oil mixture

Inspect the fuel tank and fill with clean, fresh fuel of the proper mixture. This engine requires a mixture of gasoline of between 20 and 25 parts gasoline to 1 part oil (1 gal. gasoline to 6 oz. oil) of regular leaded gasoline. Use 32-36555 Craftsman Engine Oil or a high grade two stroke cycle engine oil. For the first twenty hours, use the mixing ratio of between 15 and 20 to 1. **DO NOT USE (OUTBOARD MOTOR) OIL**
DO NOT MIX GASOLINE AND OIL DIRECTLY IN THE ENGINE FUEL TANK.

IMPORTANT: Failure to follow proper fuel mix instructions could result in serious damage to the engine.

CAUTION:

When preparing fuel mixture, mix only the amount needed for the job you are to do. Do not use fuel mixture that has been stored longer than two (2) months. Fuel mixture stored longer than this will cause hard starting and poor performance. If fuel mix has been stored longer than this time it should be removed and filled with a fresh mixture.

CAUTION! NEVER fill the fuel tank to the inlet port level.

NEVER add fuel to the tank in a closed un-ventilated area.

DO NOT add fuel to this unit close to an open fire or sparks.

BE SURE to wipe off spilled fuel before attempting to start the engine.

DO NOT attempt to refuel an extremely hot engine.

Check points before operation

CHECK for loose bolts, nuts and fittings.

CHECK the air cleaner for dirt. Clean the air filter of all dirt, etc. before the operation.

ENGINE STARTING PROCEDURE

1. When starting the engine, set the toggle switch at "ON".
2. Open the fuel valve. The valve is open when in line with the fuel line and closed when 90° to it. Figure 7.

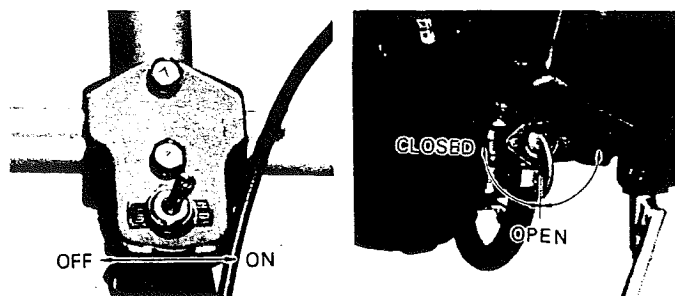

Figure 7

3. The choke control is a "Lever" type. (See Figure 8). To choke the engine, push the choke lever to "CLOSE" (CHOKE) position. NOTE: If the engine is warm, it may be started with the choke lever mid-way between "OPEN" (RUN) and "CLOSE", depending on the individual engine. Figure 8.

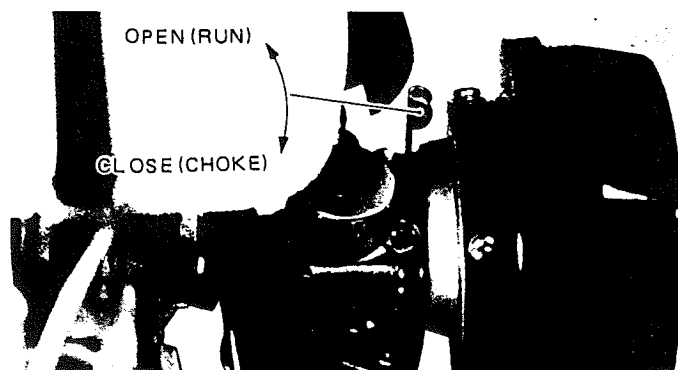

Figure 8

(continued)

Engine Starting Procedure (cont'd)

4. Set the throttle lever at starting position with the locking button of throttle lever. Figure 9.



Figure 9

5. Pull the recoil starter briskly. Figure 10 CAUTION: Gradually return the handle . . . DO NOT LET IT SNAP BACK! Pull the rope in the direction of the starter rotation. DO NOT pull the starter cord all the way out of the drum. NOTE: Use only one-half to two-thirds of your starter cord length for starting.

After the engine starts, push the choke lever to the "OPEN" (RUN) position.

6. After starting the engine, pull the throttle lever and return the locking button of throttle lever.



Figure 10

7. Let the engine warm up by running it at a low rpm (slow speed) for approximately two or three minutes. NOTE: YOU DO NOT HAVE THE ENGINE UNDER LOAD DURING THE WARM UP PERIOD.

By moving the throttle lever, increase the engine speed (rpm) to the required operating rpm before placing the unit under load (cutting).

ALWAYS reduce the engine speed to idle speed when not cutting.

CAUTION!

NEVER OPERATE THE ENGINE AT HIGH RPM WITHOUT LOAD. With throttle fully opened and no load, the engine rpm will be very high which can have an adverse effect on the life of the engine.

Stopping the Engine

1. Reduce the engine rpm to idle.
2. Set the toggle switch at "OFF". Figure 7.
3. After stopping the engine, IMMEDIATELY CLOSE THE FUEL COCK . . . shutting off the fuel supply from the tank to the engine. Figure 7.

Adjustments

SPARK PLUG MAINTENANCE — If the spark plug electrode area has an excess of carbon buildup, the efficiency of the plug will be seriously reduced. REMOVE THE CARBON WITH A SPARK PLUG CLEANER OR WIRE BRUSH.

After cleaning the spark plug RESET THE ELECTRODE GAP TO 0.6/0.7 MM (.024-.028).

Carburetor

Proper adjustment of the carburetor is very important to the operation of this engine. The carburetor has been carefully adjusted at the factory and therefore should not require any further adjustment.

Carburetor Adjustment

Idle speed adjustment is accomplished by turning the throttle stop screw.

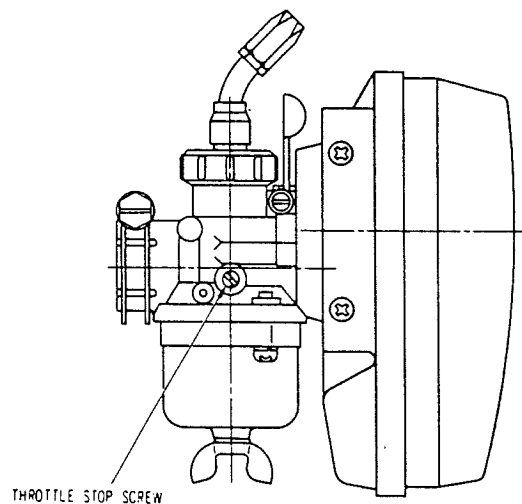

Turning the throttle stop screw clockwise will increase the idle speed. Turning the throttle stop screw counter-clockwise will decrease the idle speed.

For any additional carburetor adjustments take the complete unit to the nearest Sears Service Center.

Preventative Maintenance Check List and Storage Tips

Be sure the engine and all other parts are clean.

Check all nuts, bolts, screws, etc. making sure they are tightened and secured as they should be.

Inspect carefully for any fuel or oil leaks.

Check the air cleaner assembly for excessive dust or dirt. If the filter requires cleaning, use the following procedure: Remove the filter and wash in soap and water or blow off with compressed air. DO NOT clean filter in gasoline or other flammable solvent.

Tips for Long Storage

Drain all fuel from the fuel tank and carburetor. Remove spark plug, pour a teaspoon of oil through the plug hole. Rotate the crankshaft several times by pulling the starter handle slowly. Replace the spark plug and proceed with storage.

BRUSH CUTTER OPERATION

CAUTION:

Shoulder harness must be worn, and both hands kept on the handlebar grips at all times during brush cutter operation. Positive control is mandatory for safe operation. **DO NOT EDGE WITH METAL BLADE!**

The brush blade was exclusively designed for its shear cutting action. It has a much faster cutting ability than conventional, bar type, rotary blades. The brush cutter blade will effectively cut all growth, up to 2" in diameter, flush to the ground, leaving no unsightly or dangerous stumpage.

For clearing large areas the unit should be used similar to the mowing action, or a swing scythe applying large semi-circular swings of 6-7 feet advancing forward approximately five inches with each swing. Cutting heavier growth with the brush blade will require slower action. After you are acquainted with this type cutting action . . . you will want to control the swinging with the hip rather than to put the full workload on the arms and hands. Avoid "WRAPPING" when cutting some types of growth such as wire grass, Johnson grass, dead, dry, long stem weeds, grass or vines; there is a possibility of this material "WRAPPING" around the blade shaft. This action can stall the blade and cause the clutch to slip. To avoid this problem, the unit should be operated at full throttle, swinging the machine into the materials to be cut and avoiding the material just cut, as you make the return swing.

IMPORTANT:

Clean and inspect cutter shaft periodically, remove debris, etc. to insure optimum operation.

CAUTION

Stop engine before removing grass or weed wrappings.

Sharpening the brush blade . . . the brush blade should be kept sharp at all times. When cutting for any length of time keep a file handy; a few strokes now and then will keep the blade sharp and cutting precisely. **CAUTION:** Always shut the engine down to sharpen the blade. When sharpening the blade in the shop be sure it is straight. Lay the blade on a flat surface to determine if it is straight. Always replace a bent blade, do not attempt to straighten and re-use.

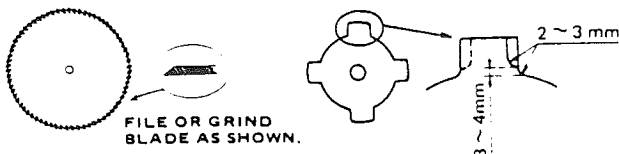

Use the 4-tooth blade only for mowing. If 4-tooth blade is worn out, grind the base of blade into round curve as shown above.

Emergency measure during operation

In case of emergency, pull the detaching belt upward strongly and the machine will be detached from the body.

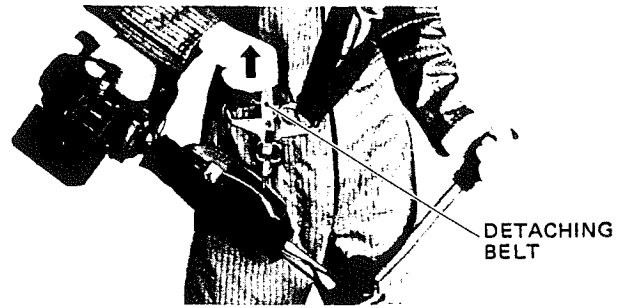

Caution! Lubrication points Figure 11

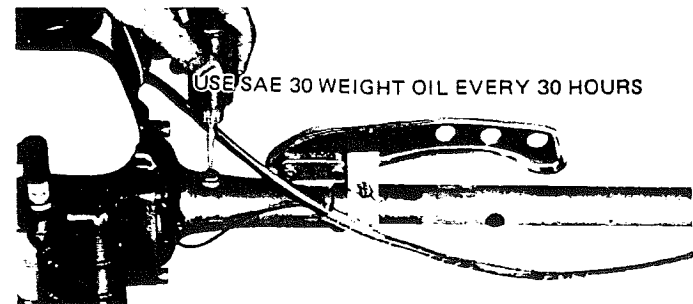
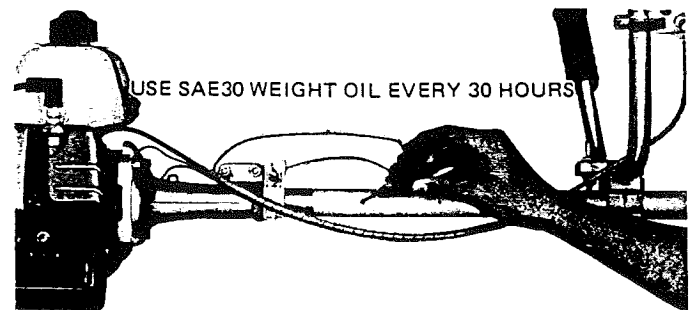

LITHIUM WHITE GREASE and SAE 30 weight Oil are available at SEARS, ROEBUCK AND CO. Figure 12

NYLON LINE TRIMMER INSTRUCTIONS

HOW TO USE THE LINE TRIMMER

The Line Trimmer is designed for trimming and light edging work. It uses only the (very) tip of a monofilament nylon line specially-treated for longer wear. The life of the cutting line depends upon the type of surface against which you are cutting. It will wear faster when you are cutting against rocks, bricks, concrete, metal fences, etc. than it will against trees or wooden fences. The line may cut tender bark of trees or shrubs and could scar fences. Learning the proper technique of cutting around objects is very important.

SAFETY RULES AND PRECAUTIONS

Proper safety precautions must be observed. The Line Trimmer does not have fast-moving, sharp metal blades but, like all power equipment, must be handled carefully. **DO NOT EXPOSE YOURSELF OR OTHERS TO DANGER.** Follow these simple rules:

1. Always wear safety goggles for eye protection. Dress properly, do not wear loose clothing or jewelry that could become caught in moving parts of the unit. Safe footwear should always be worn.
2. Inspect the entire machine for loose parts. (Nuts, bolts, screws, etc.)
3. **NEVER USE WIRE IN PLACE OF THE MONOFILAMENT CUTTING LINE.** The tip will break off during cutting and could become a dangerous missile.
4. Keep the handles free of oil and fuel.
5. Do not smoke while mixing fuel or filling the tank.
6. Do not mix fuel in an enclosed room or near open flames.
7. Always mix and store the fuel in a properly marked container that is approved for such usage.
8. Never remove the fuel tank cap while the engine is running.
9. Never start or run the engine inside a closed room or building. Fumes from the exhaust contain dangerous carbon monoxide.
10. Never attempt to make engine adjustments while the unit is running and strapped to the operator. Always make engine adjustments with the unit resting on a flat, clear surface.
11. Do not use the unit if it is damaged or poorly adjusted.
12. Inspect the area to be cut and remove all debris that could become entangled in the nylon cutting head. Also remove any objects that the unit may sling during cutting.
13. Keep children away. Onlookers should be kept at a safe distance from the work area, at least 30 feet.
14. Do not use this unit for any job other than those for which it is intended as described in this manual.
15. Do not use this unit to cut or trim anything over waist high.
16. Do not overreach. Keep proper footing and balance at all times. Do not run unit standing on a ladder or any other unstable footing.
17. Keep hands and feet clear of the nylon cutting head while unit is in use.
18. Do not run the unit at high speed when not cutting.
19. Do not use the unit when you are tired.
20. Maintain the unit with care. Always keep the cutting line at the proper length and the blade sharp. Follow instructions for changing accessories.
21. Do not store in a closed area where fuel vapors can reach an open flame from hot water heaters, furnaces, etc.
22. Use only replacement parts that are identical to original equipment parts when servicing the unit. These parts are available from your dealer. The use of any other accessory or attachment may create a potential hazard.

ASSEMBLY

To assemble your unit, follow the procedures listed below:

1. **NYLON CUTTING HEAD - LINE TRIMMER**
Assemble cup washer, and nylon cutting head as shown in Figure 13. Align the hole in the lower head with the hole in the cup washer. Insert the Lock Handle thru the Holes as shown, locking the drive shaft. While holding on to the Lock Handle, screw the nylon cutting head on by turning in the direction shown.

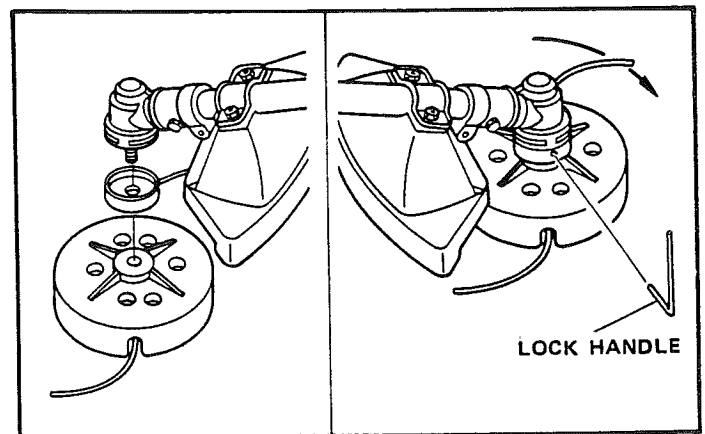

Figure 13

NOTE: For nylon cutting head removal, reverse the procedure. By turning the nylon cutting head in the opposite direction.

ENGINE OPERATION

To obtain maximum engine performance and efficiency, observe the following recommendations:

1. Always accelerate the engine to the desired cutting line speed before cutting.
2. Never operate the engine at a higher speed than necessary, as this decreases the Line Life.

Engine Operation (cont'd.)

3. Always release the trigger and allow the engine to return to idle speed when not cutting.
4. The carburetor has been carefully adjusted at the factory and should not require any further adjustment. For carburetor adjustment, see ENGINE ADJUSTMENTS section in this manual.
5. To stop engine, move the toggle switch to the "OFF" position. Figure 7.

Proper length of cutting line is 7 inches as measured from eyelet to end of line.

CUTTING PROCEDURES

Always remember, "the tip of the line does the cutting." You will achieve better results by not crowding the line into the cutting area. Allowing the unit to trim at its own pace, the right way and wrong way is illustrated in figures 14 and 15.

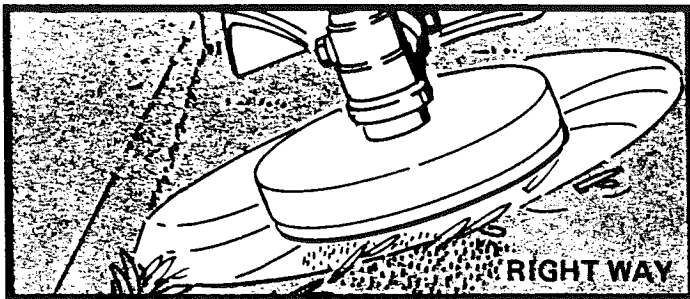

Figure 14

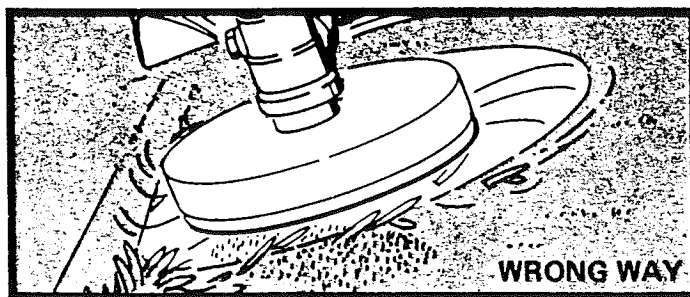

Figure 15

CAUTION

Operating any line trimmer could throw objects into the eyes. This could cause severe eye damage. Always wear safety glasses or eye shields during operation.

Your trimmer is a versatile tool which can easily perform the following lawn care operations:

A. TRIMMING

The proper trimming position is shown in figure 16. Maintaining a 30 degree angle to the cutting area allows for more efficient trimming. Do not force the cutting line into the work area. Allow the tip of the line to do the cutting.



Figure 16

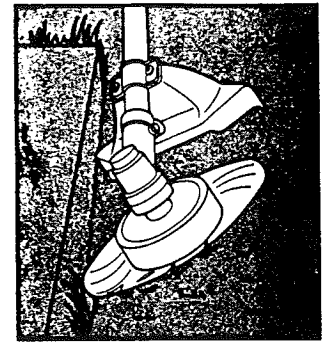

B. MOWING

Your trimmer is ideal for mowing in places conventional lawn mowers cannot reach. The proper position for mowing is shown in figure 17. In this position, the cutting line is parallel to the ground. With practice, this technique will provide the results illustrated. When mowing, avoid pressing the head into the ground as this can cause damage to your unit.

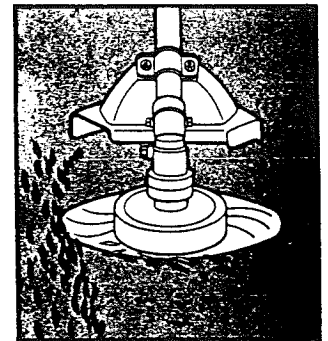

Figure 17

C. EDGING

Adjust the drive tube and handle to position the cutting line as shown in figure 18.

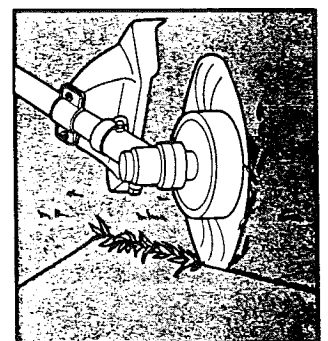

Figure 18

WARNING!

Never lean over the nylon cutting head. Rocks or other debris could be thrown into eyes and face and cause serious injury or blindness. ALWAYS WEAR SAFETY GOGGLES FOR EYE PROTECTION

D. SCALPING

To remove all unwanted vegetation around trees, posts, monuments, etc., maintain a 30 degree angle with the nylon cutting head and allow the tip of the cutting line to strike the ground. Figure 19.

NOTE: Increased line wear is to be expected when using the edging or scalping techniques.

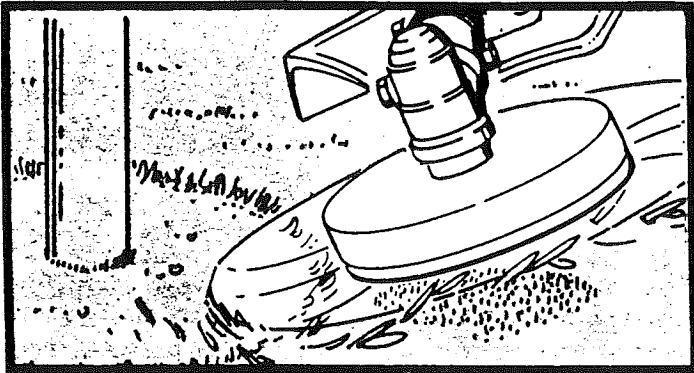

Figure 19

E. SWEEPING

For quick and easy clean up, extend the line to approximately 7" and "sweep" the cutting debris from a walk or driveway. Move the unit from side to side, keeping the nylon cutting head parallel to the surface being swept, as shown in figure 20.

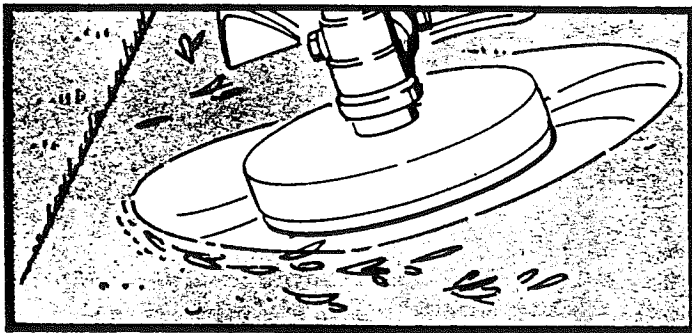

Figure 20

LINE & SPOOL MAINTENANCE

A. NYLON CUTTING HEAD

1. The nylon cutting head supplied with this unit is a manual type.

B. LINE ADJUSTMENT

1. Remember that line wear is as normal as the dulling of a metal blade. The life of the line will depend on your cutting technique and the surface against which you are trimming. Do not operate at a higher speed than is necessary to perform the required cutting.
2. When the line wears down, loosen knob on bottom of head by turning counter clockwise four turns. Then by gripping lower ring, pull down and turn counter clockwise at the same time to the next notch, or amount desired. Retighten knob. Figure 21.

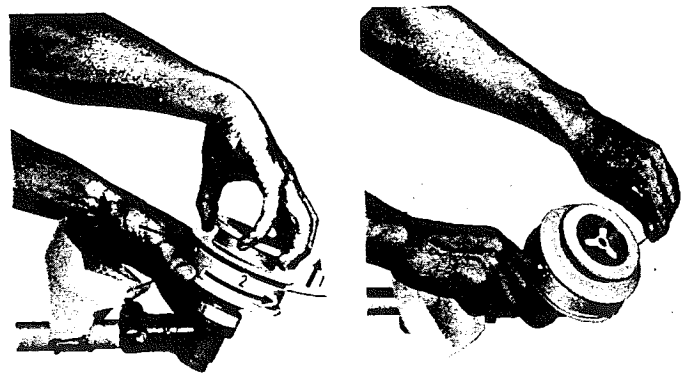

Figure 21

C. THE SPOOL

When it becomes necessary to rewind or replace the spool, the following procedure should be used:

1. Remove knob all the way from bottom of head. Figure 22.



Figure 22

2. Separate interspool from housing. Figure 23.

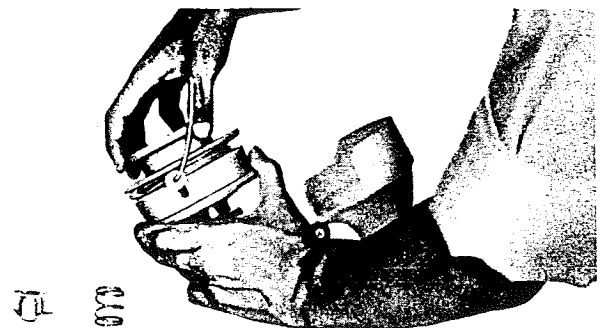

Figure 23

3. NOTE two small holes on interspool. Equal amounts of cord should be indexed at both sides of interspool by inserting nylon cutting cord in one hole and guiding it through the center of spool and out the other side. Following arrow on bottom of interspool, with nylon in direction of arrow. Do not over fill interspool. Capacity of nylon cutting cord is 30 feet and diameter of cutting cord is .080". Figure 24.

Line & Spool Maintenance (cont'd)

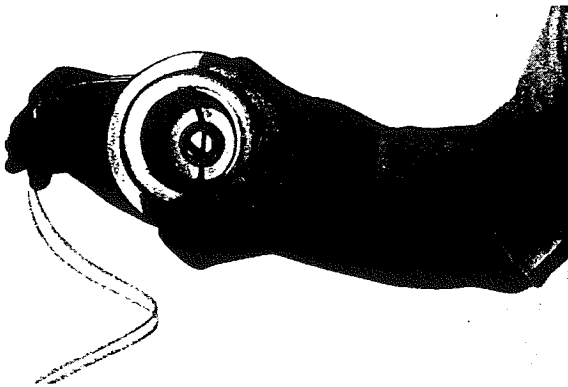

Figure 24

- There are two eyelets, one on each side. After the nylon cord has been threaded through eyelets with thick side facing shaft holt, (may not be applicable on all heads), inset eyelets in side slots of housing while inserting interspool. Thus snapping together both interspool and eyelets in housing with one motion. Clip ends of nylon to equal lengths. Thread knob back on shaft and retighten. See figure 25.

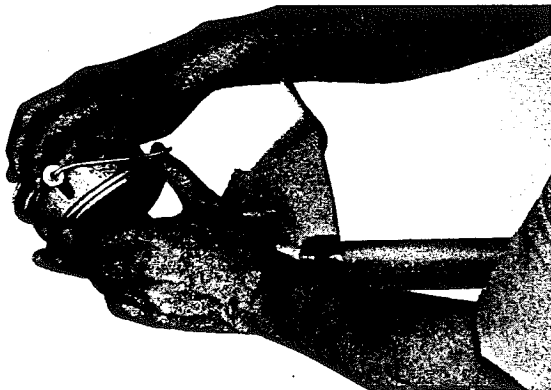

Figure 25

Caution: Nylon cutting cord must be one continuous length, with interspool centered! If separate pieces are used on each side serious injury may result as you near the end of use on nylon cord. Eyelets must be used or the line can cut through the spool housing and possibly destroy the operation of the nylon cutting head.

GENERAL MAINTENANCE

- LUBRICATION**
FOLLOW INSTRUCTIONS! After every 10 hours of operation, remove the plug and fill gear box with grease.

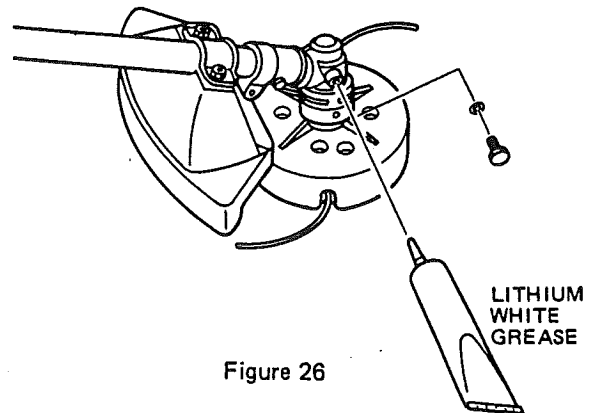
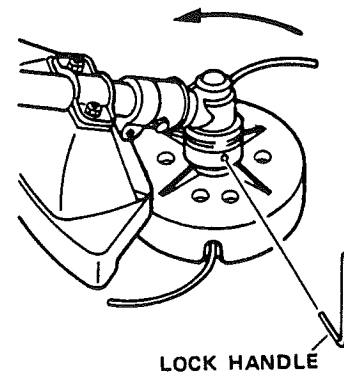

Figure 26

Removing the Trimmer Head

To remove the Trimmer Head (nylon cutting head) do this: Align the hole in the lower head with the hole in the cup washer. Insert the Lock Handle which is included in the BRUSHWACKER™ tool kit thru the hole as shown thus locking the drive shaft. Holding on to the Lock Handle, unscrew the Universal Head by turning in the direction shown.

TURN THIS WAY TO REMOVE.



Provided in tool kit.
Figure 31 Key 24 on page 18.
Figure 27

SEARS BRUSHWACKER™. PARTS LIST - MODEL 636. 795454

Figure 28

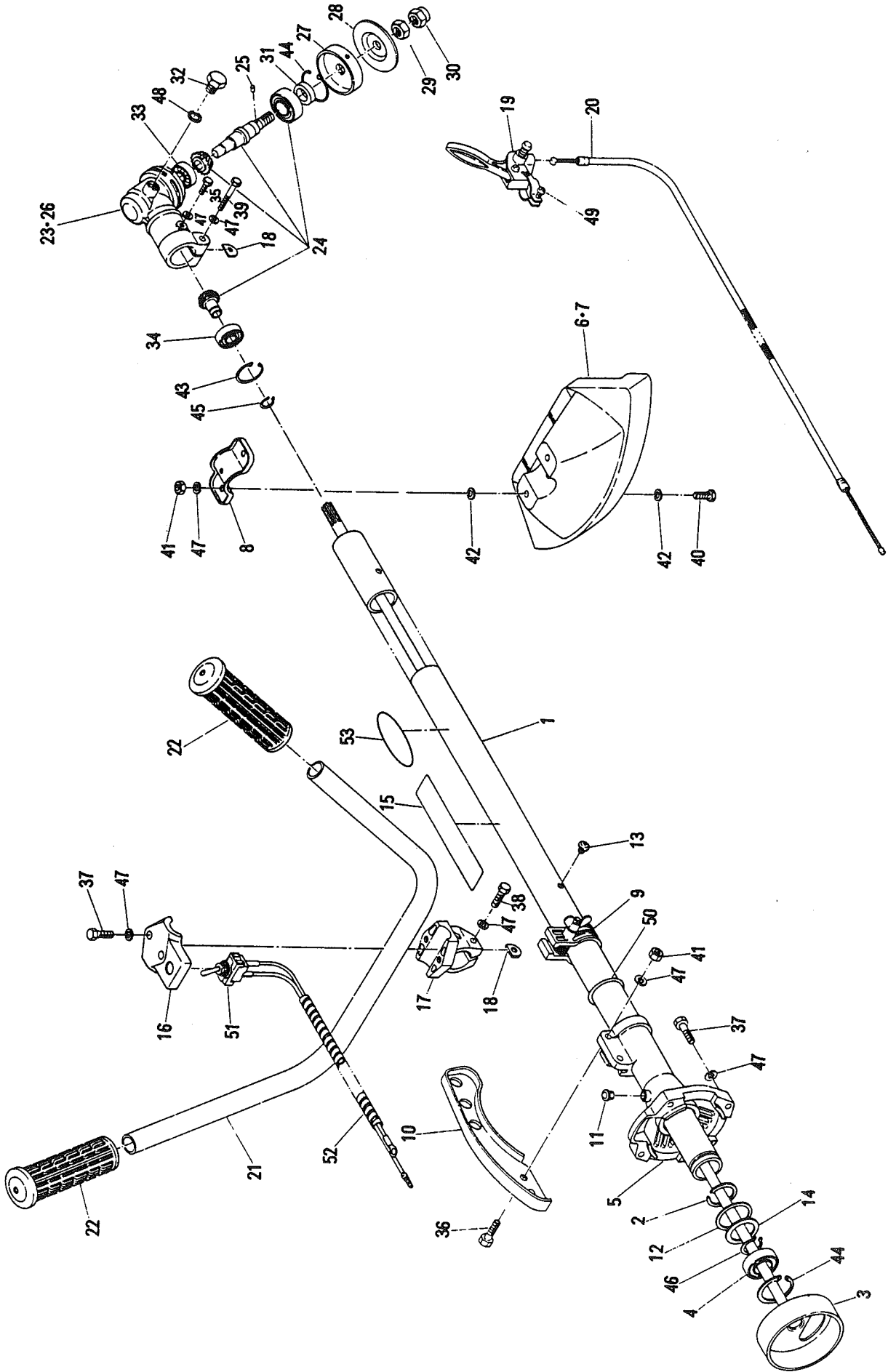

SEARS BRUSHWACKER™ PARTS LIST - MODEL 636. 795454

Figure 28

KEY NO.	PART NO.	QTY.	DESCRIPTION	KEY NO.	PART NO.	QTY.	DESCRIPTION
1	NB03D-099/1	1	Pipe case compl. (incl. 2)	40	00170-0625-0	2	Bolt (cross-recessed)
2	NB03-121	1	Snap ring (outer)	41	00218-0600-0	4	Nut
3	NB04D-098A	1	Long shaft ass'y (incl. 4, 44, 46)	42	00312-0600-0	4	Washer
4	0600-17985-0	1	Ball bearing	43	00314-2800-0	1	Snap ring (inner)
5	NB03D-091/1	1	Pipe case holder compl. (incl. 50)	44	00314-3500-0	2	Snap ring (inner)
6	NB03D-0501A	1	Splash deflector unit (incl. 7,8,40,41,42,47)	45	00315-1200-0	1	Snap ring (outer)
7	NB03D-5101A	1	Splash deflector	46	00315-1700-0	1	Snap ring (outer)
8	NB03D-5102	1	Splash deflector fixture	47	00320-0600-0	14	Spring washer
9	NB03D-057	1	Detent unit	48	00371-1000-0	1	Gasket (fiber)
10	NB03-109/2	1	Hanging metal	49	00431-0520-0	1	Screw (pan head)
11	NB03-110	1	Oil cup	50	00626-3028-0	1	O-ring
12	NB03-122	1	Washer	51	NB03D-0420	1	Toggle switch compl.
13	NB03D-133A	1	Blank plug	52	NB03D-4130A	1	Spiral tube
14	0230-25999-0	0 Or 1	Spacer	53	NB04D-9124	1	Label
15	NB04D-9123	1	Label				
16	NB03D-4110/2	1	Handle fixture A				
17	NB03-403/3	1	Handle fixture B				
18	0210-06999-0	2	Gasket (fiber)				
19	NB03D-014A	1	Throttle lever ass'y				
20	NB03-094A	1	Throttle wire compl.				
21	NB04-401D	1	Handle				
22	NB04D-4120	2	Grip				
23	NB04-058E	1	Cutter head unit (incl. 18,24 thru 35,39, 43,44,45,47,48)				
24	NB04D-068A	1	Cutter shaft set (incl. 25)				
25	0310-04999-0	1	Dowel pin				
26	NB03-301/7	1	Gear case				
27	NB03D-3110	1	Cup washer				
28	NB03D-3111A	1	Clamp washer				
29	NB03-310/2	1	Clamping nut				
30	NB03-311/1	1	Cap nut				
31	0230-15998-0	1	Spacer				
32	0400-10998-1	1	Plug				
33	0600-10998-0	1	Ball bearing				
34	0600-12994-0	1	Ball bearing				
35	00166-0612-0	2	Bolt				
36	00166-0620-0	2	Bolt				
37	00166-0625-0	6	Bolt				
38	00166-0630-0	1	Bolt				
39	00167-0635-0	1	Bolt				

SEARS BRUSHWACKER™ PARTS LIST - MODEL 636 .795454

Figure 29

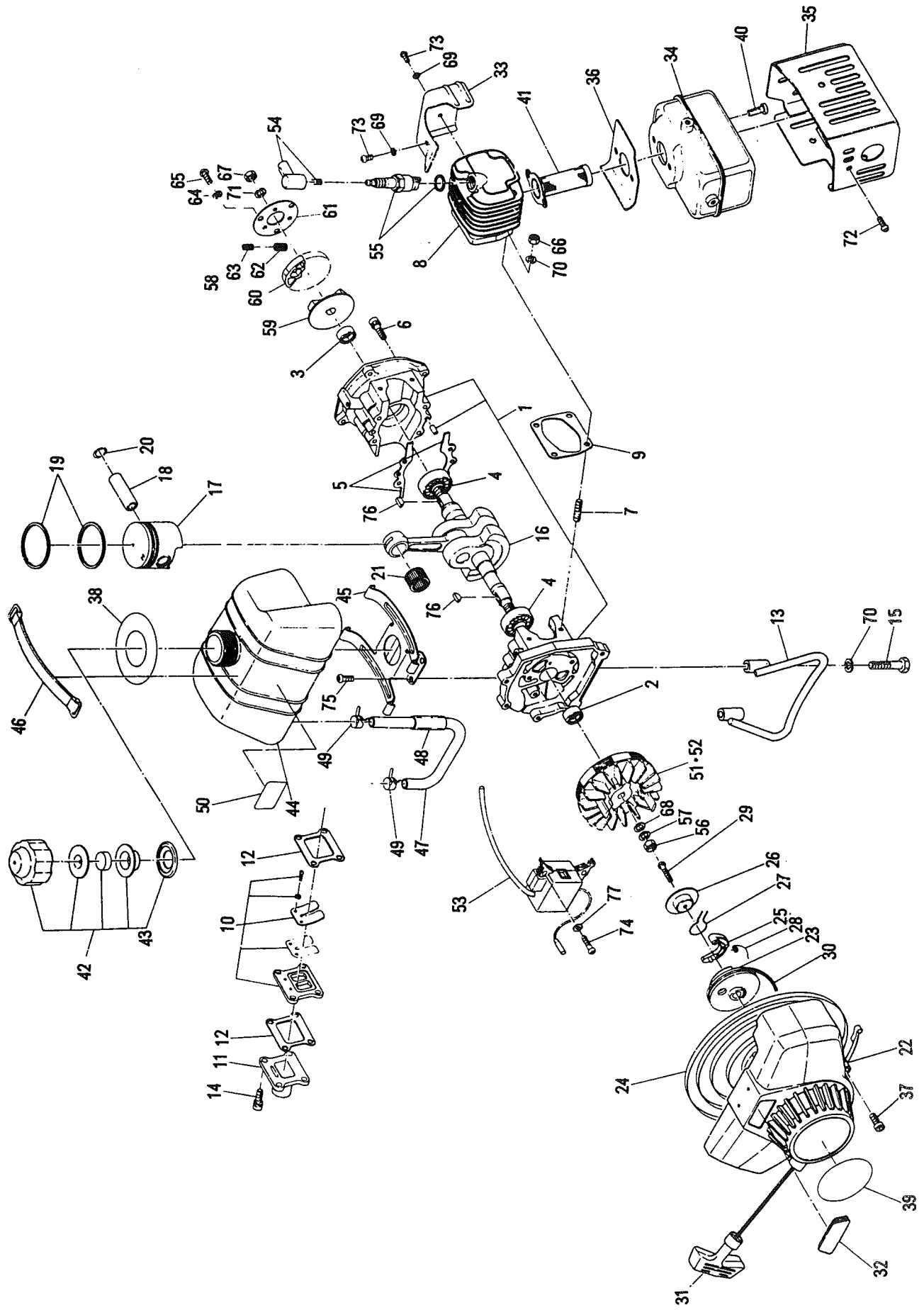

SEARS BRUSHWACKER™. PARTS LIST - MODEL 636. 795454

Figure 29

KEY NO.	PART NO.	QTY.	DESCRIPTION	KEY NO.	PART NO.	QTY.	DESCRIPTION
1	EC04-072	1	Crank case compl. (incl. 2 thru 7)	40	0119-06999-0	2	Bolt (socket head)
2	0440-12999-1	1	Oil seal (front)	41	EC04-0372	1	Spark arrester ass'y
3	0440-15997-1	1	Oil seal (rear)	42	EC02-083	1	Fuel tank cap compl. (incl. 43)
4	0600-15988-0	2	Ball bearing	43	EC02-644	1	Packing
5	EC03-071	1	Crank case packing set	44	EC04-6131	1	Fuel tank
6	0119-05994-0	4	Bolt (socket head)	45	EC03-303D	1	Fuel tank stand
7	0105-06994-0	4	Stud	46	EC04-304A	2	Tank band
8	EC04-1051	1	Cylinder	47	EC03-6101	1	Fuel pipe
9	EC03-109A	1	Cylinder packing	48	EC03-6103	1	Protective pipe
10	EC03-091	1	Lead compl.	49	0561-13998-2	2	Hose clamp
11	EC03-104B	1	Carburetor bracket	50	EC03-9110	1	Label (caution)
12	EC03-115	2	Lead bracket packing	51	EC04-0704A	1	Solid state magnet compl. (incl. 52, 53)
13	NB03D-523	1	Stand	52	11100080020	1	Magnet wheel
14	0119-05995-0	4	Bolt (socket head)	53	11400170050	1	Solid state unit
15	00166-0640-0	2	Bolt	54	KM61-088C	1	Plug cap compl.
16	EC04-062	1	Crankshaft compl.	55	0650-14995-0	1	Spark plug (NGK B7HS)
17	EC04-206/2B	1	Piston	56	0170-08996-0	1	Nut (left)
18	EC04-207A	1	Piston pin	57	0203-08999-0	1	Spring washer (left)
19	EC04-210A	2	Piston ring	58	NB03D-0201A	1	Clutch compl. (incl. 59 thru 65)
20	0565-11999-0	2	Clip	59	NB03-203	1	Retainer
21	0610-12996-1	1	Needle bearing	60	NB03D-2101	3	Clutch shoe
22	EC04-0510G	1	Recoil starter compl. (incl. 23 thru 31)	61	NB03D-204A	1	Shoe keep plate
23	A54103200100	1	Reel	62	NB03-208	3	Spring A
24	A60003200000	1	Spiral spring	63	NB03-209	3	Spring B
25	A55003210001	1	Ratchet	64	00320-05000-0	3	Spring washer
26	A56003200090	1	Friction compl.	65	00431-0510-0	3	Screw (pan head)
27	A60102600000	1	Friction spring	66	00218-0600-0	4	Nut
28	A60503210000	1	Return spring	67	00228-0800-0	1	Nut
29	141051251002	1	Bind screw	68	00310-0800-0	1	Washer
30	A57120950000	1	Starter rope	69	00320-0400-0	2	Spring washer
31	A30501100001	1	Starter knob compl.	70	00320-0600-0	6	Spring washer
32	EC04-5108	1	Rubber plug	71	00320-0800-0	1	Spring washer
33	EC03-5121G	1	Cylinder cover	72	0140-05996-0	4	Screw
34	EC03-0367	1	Fire safety muffler	73	00431-0408-0	2	Screw (pan head)
35	EC03-0305	1	Fire safety muffler cover ass'y	74	00431-0416-0	2	Screw (pan head)
36	EC03-3122	1	Fire safety muffler gasket	75	00431-0512-0	3	Screw (pan head)
37	0119-05999-0	3	Bolt (socket head)	76	00532-0310-0	2	Woodruff key
38	EC04-9109	1	Mixture label	77	00311-0400-0	2	Washer
39	NB04D-9122/2	1	Label				

SEARS BRUSHWACKER™. PARTS LIST - MODEL 636 . 795454

Figure 30

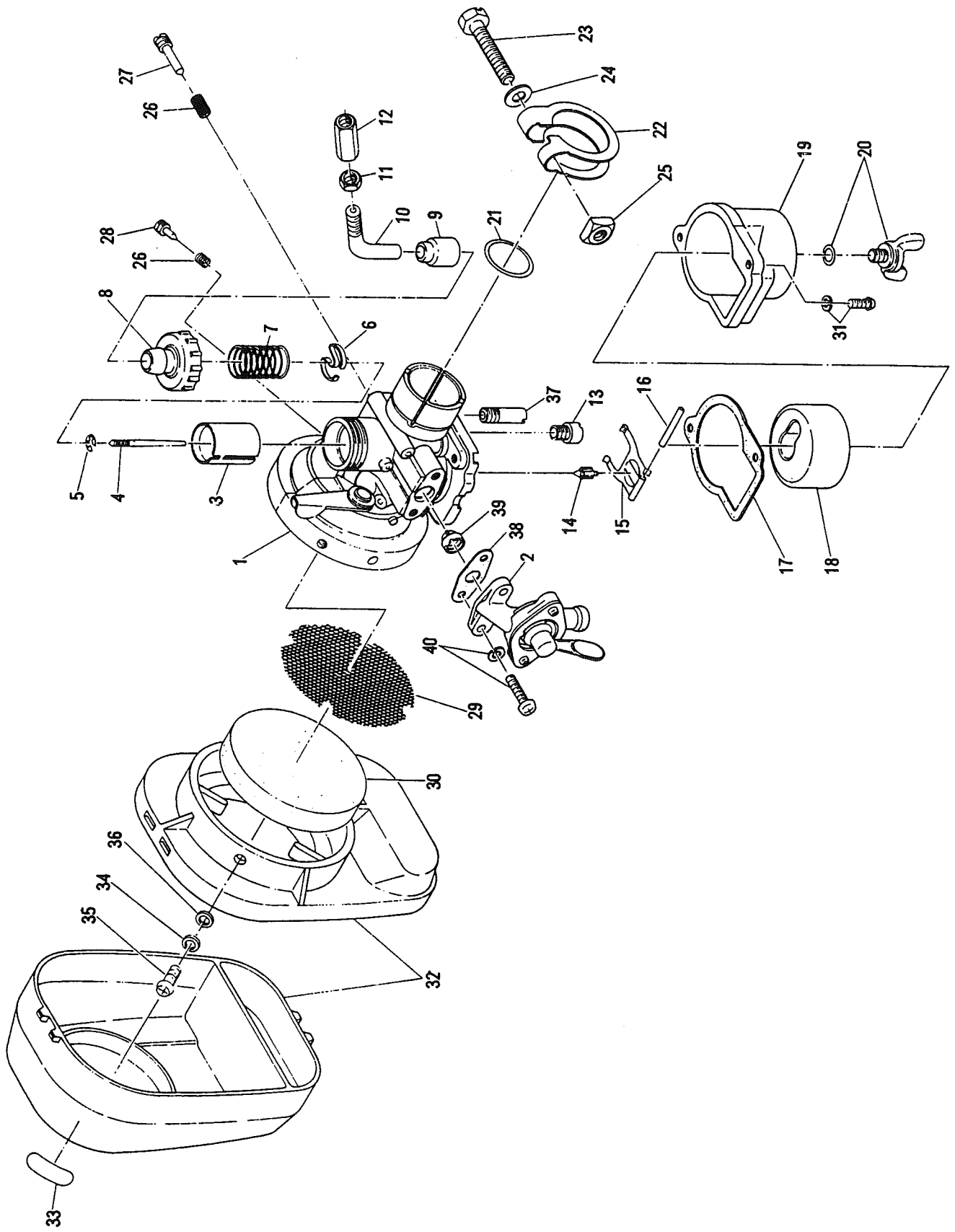

SEARS BRUSHWACKER™. PARTS LIST - MODEL 636. 795454

Figure 30

KEY NO.	PART NO.	QTY.	DESCRIPTION
1	EC04-0663	1	Carburetor compl. (incl. 2 thru 31, 37 thru 40)
2	CK/31	1	Cock body ass'y
3	VM15/151B	1	Piston valve (#1.5)
4	J8-3N06	1	Jet needle
5	MD14/40	1	E-ring
6	VM14C1/38B	1	Spring seat
7	VM15/24A	1	Spring
8	VM16/200	1	Top
9	VM12/43	1	Cap
10	MD13/44	1	Cable guide
11	M21/15	1	Lock nut
12	VM24/148	1	Cable adjuster
13	N102-221	1	Main jet (#70)
14	VM15/173	1	Needle ass'y
15	VM15/353	1	Float arm
16	VM15/264	1	Pin
17	VM15/351	1	Gasket
18	VM13/139	1	Float
19	VM13/188	1	Float chamber body
20	EC03-S0010	1	Guide screw
21	VM13/68A	1	O-ring
22	VM13/211	1	Clip
23	B2-0630	1	Bolt
24	B34/83	1	Washer
25	389/067	1	Square nut
26	M12F/46A	2	Spring
27	VM15/30	1	Throttle stop screw
28	MD16/15A	1	Air screw
29	VM13/98A	1	Net
30	VM13/121	1	Filter
31	CW2-0416	2	Spring washer cross screw
32	EC03-0338	1	Silencer compl. (incl. 33)
33	0737-30995-0	1	Label
34	00320-0400-0	4	Spring washer
35	00431-0410-0	4	Screw (pan head)
36	00310-0400-0	4	Washer
37	VM13/164	1	Pilot jet (#35)
38	VM15/348	1	Gasket
39	VM13/210	1	Filter
40	CW2-0414	2	Spring washer screw

SEARS BRUSHWACKER™ PARTS LIST - MODEL 636 . 795454

Figure 31

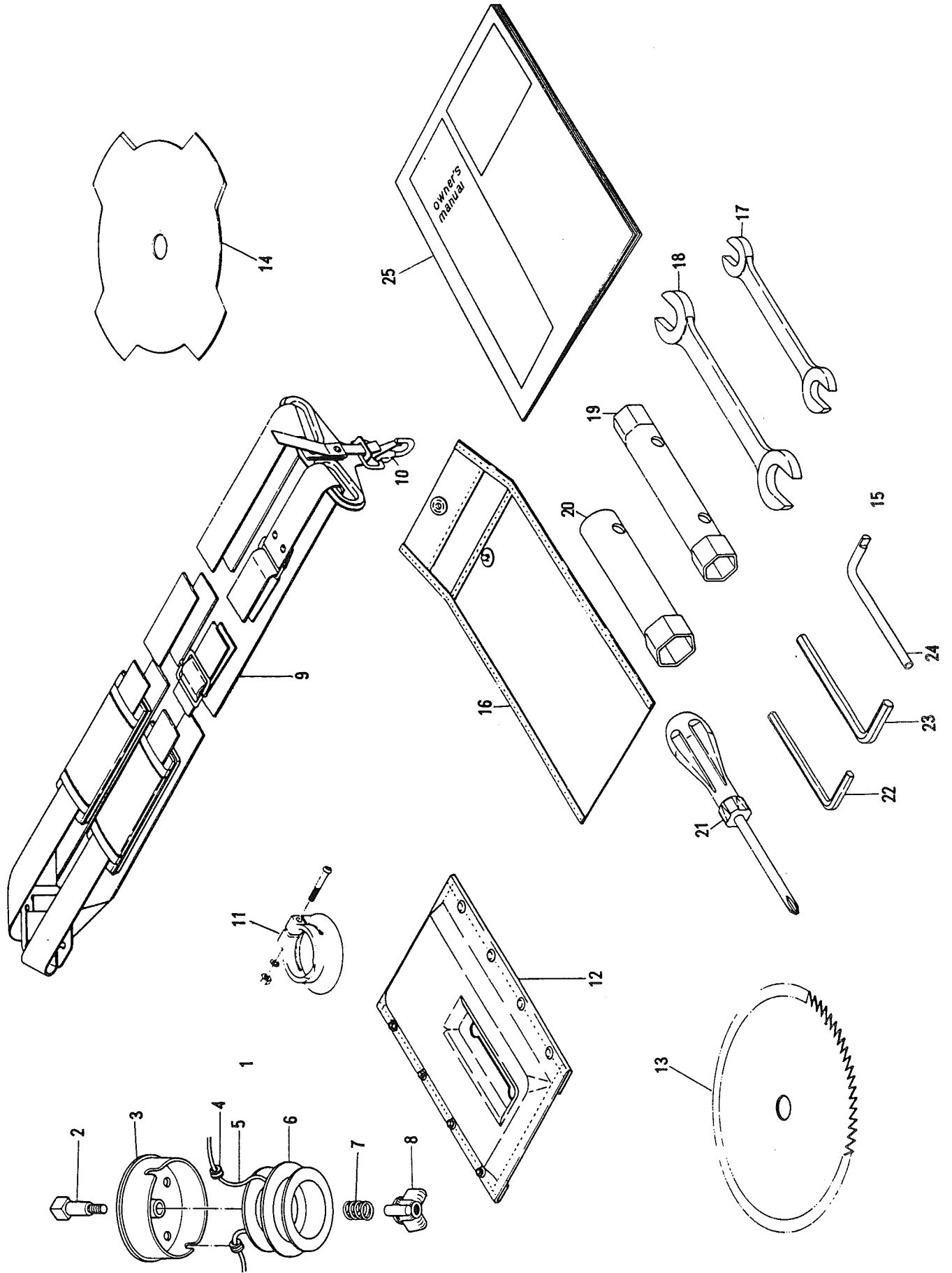

SEARS BRUSHWACKER™. PARTS LIST - MODEL 636. 795454

Figure 31

KEY NO.	PART NO.	QTY.	DESCRIPTION
1	NB04D-0520	1	Nylon cutting head kit (incl. 2 thru 8)
2	NB04D-5120	1	Shaft bolt
3	NB04D-5121	1	Spool housing
4	NB04D-5122	2	Eyelets
5	NB04D-5123	1	Nylon cutting
6	NB04D-5124	1	Interspool
7	NB04D-5125	1	Spring
8	NB04D-5126	1	Knob
9	NB03D-092C	1	Shoulder harness compl. (incl. 10)
10	NB03D-937A	1	Hook
11	NB03C-066/1B	1	Arbor lock
12	NB04CII-908C	1	Waist pad
13	NB04D-8101D	1	10" multi tooth heavy brush blade
14	NB04D-8102A	1	10" weed blade
15	NB04C-093C	1	Tool kit (incl. 16 thru 24)
16	0700-00996-0	1	Tool bag
17	0710-10500-1	1	Double-end wrench(10 x 12 M/M Approx. 26 ¹ / ₆₄ " x 31 ¹ / ₆₄ "
18	0710-14999-1	1	Double-end wrench(14 x 17 M/M Approx. 36 ¹ / ₆₄ " x 43 ¹ / ₆₄ "
19	0712-14999-1	1	Box wrench(14 x 17 M/M Approx. 36 ¹ / ₆₄ " x 43 ¹ / ₆₄ "
20	0713-21999-1	1	Box wrench(21 M/M Approx. 54 ¹ / ₆₄ "
21	0715-06998-1	1	Plus driver
22	0717-04999-0	1	Wrench-socket head(4 M/M Approx. 10 ¹ / ₆₄ "
23	0717-05999-0	1	Wrench-socket head(5 M/M Approx. 13 ¹ / ₆₄ "
24	NB03-920	1	Lock handle
25	NB04D-9150/3	1	Owner's manual

Sears

**MODEL NO.
636.795454**

How to Order Repair Parts

**SEARS SERVICE
IS AT YOUR SERVICE**

The Model Number will be found on the top of recoil starter. Always mention the Model Number when requesting service or repair parts for your unit.

All parts listed herein may be ordered from any SEARS, ROEBUCK AND CO. OR SIMPSONS-SEARS LIMITED retail or catalog store.

WHEN ORDERING REPAIR PARTS, ALWAYS GIVE THE FOLLOWING INFORMATION AS SHOWN IN THIS LIST.

1. The PART NUMBER
2. The MODEL NUMBER of the BRUSHWACKER™. 636. 795454
3. The PART DESCRIPTION
4. The NAME OF ITEM— 37.7cc Gas BRUSHWACKER™.

If the parts you need are not stocked locally, your order will be electronically transmitted to a Sears Repair Parts Distribution center for expedited handling



When you buy merchandise from Sears you get an extra something that nobody else can offer . . . Sears Service.

Across town or across the country, Sears Service follows you, providing trustworthy, competent service technicians using only Sears specified factory parts.

Your Sears Merchandise Takes on added value when you discover that Sears has Service Units throughout the country. Each is staffed by Sears-Trained, professional technicians using Sears approved methods.

Sears, Roebuck and Co., Chicago, Ill. 60684 U.S.A.