

KOLSOL®

Your excellent helper in cable test!

INSTRUCTION MANUAL

Underground Wire Locator



Your excellent helper in cable test!



F02



F02 Pro



REV5.0

Contents

1.DESCRPTION	1
1.1 Function comparision.....	1
1.2 Glossary.....	2
1.3 Specification	4
2.OPERATION	6
A.Transmitter Connection	6
B.Locating & Tracking Buried Wires	6
C.Measuring Depth	7
D.Tracking Behind Walls	7
E.Locating Circuit Breaker	8
F. Pinpointing Drill Sites	9
G.Determining which receptacles are on specific circuits..	10
H.Locating Alarm, Sound & Computer Wires	10
II. External Earphone	10
J.Locating Hidden Receptacles	10
K.White LED Flash Light	10
4.MAINTENANCE	11

1. DESCRIPTION

1. The Underground Wire Locator is designed to locate the path of non-energized wires behind walls and underground. it is also capable of locating a specific circuit breaker, pinpointing wires before drilling and verifying dig sites underground.
2. The unit consists of a transmitter, equipped with a thumb wheel switch for turning the unit on and adjusting the output level, Push the switch to select to test “Cable Scan”.
3. The receiver, is equipped with a thumb wheel switch for turning the unit on and adjusting the receiver gain.
4. The alligator clip leads are available to connect to wires.

WARNINGS:

1. Only to locate non-energized Cable or low-voltage less than 24V.
2. Capable to detect single-core wires or parallel double-core wires, Not for multi-strand wires!!!
3. Better not to used on irrigation or sprinkler valve

1.1.Function comparision

Description	NF-F02	F02 Pro
Trace underground cable pipe	√	√
Depth range	2 feet	3 feet
Max cable length	1000 feet	2000 feet
Working environment	0-24V	0-24V
Power supply	9V battery	3.7V Lithium battery
Color	Yellow	Dark blue

1.2. Glossary

Item No: F02



1	Thumb Wheel Switch	7	Push For Lamp
2	Transmitter power indicator	8	Antenna
3	Transmitter Switch	9	LED Flash Light
4	Status indicator	10	Earphone Jack
5	Alligator Clips & Leads	11	Thumb Wheel Switch
6	Receiver power indicator	12	ON/OFF Switch

Item No: F02 Pro

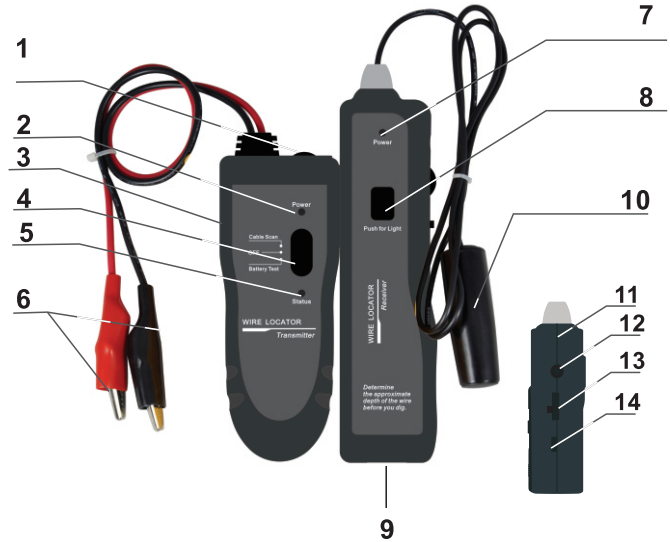

1	Thumb Wheel Switch	8	Push For Lamp
2	Transmitter power indicator	9	Charging Port
3	Charging Port	10	Antenna
4	Transmitter Switch	11	LED Flash Light
5	Status indicator	12	Earphone Jack
6	Alligator Clips & Leads	13	Thumb Wheel Switch
7	Receiver power indicator	14	ON/OFF Switch

1.3. Specifications

F02 Transmitter specification	
Tone frequency	200kHz
The Max length distance	1000 feet
The Max depth distance	2 feet
The Max. working current	Less than 70mA
Max. signal voltage	15Vp-p
Signal display	Tone
Battery type	DC9.0V (NEDA 1604/6F22) x 1 pc
Dimensions (LxWxD)	49 x 135 x 33mm
F02 Receiver specification	
Frequency	200kHz
The Max. working current	Less than 70mA
Earphone jack	1
Battery type	DC9.0V (NEDA 1604/6F22) x 1 pc
Dimensions (LxWxD)	43 x 168 x 27mm

F02 Pro Transmitter specification	
Tone frequency	200kHz
The Max length distance	2000 feet
The Max depth distance	3 feet
The Max. working current	Less than 70mA
Max. signal voltage	15Vp-p
Signal display	Tone
Battery type	Lithium battery 3.7V 1500mAh
Dimensions (LxWxD)	49 x 135 x 33mm
F02 Pro Receiver specification	
Frequency	200kHz
The Max. working current	Less than 70mA
Earphone jack	1
Battery type	Lithium battery 3.7V 1500mAh
Dimensions (LxWxD)	43 x 168 x 27mm

2. OPERATION

A. Transmitter Connection

To locate non-energized cable, Push transmitter switch to “Cable Scan” . There are two options for connection. You can connect the red lead of the transmitter to the cable and the black lead to grounded earth or you can connect one conductor with grounded earth of a non-shielded drop wire. You can also connect two conductors to non-shielded drop wire.

B. Locating & Tracking Buried Wires

To locate buried electrical wires, CATV coax, telephone drops, irrigation control wires or metallic pipes, Push transmitter switch to “Cable Scan” attach the black alligator clip lead to an independent grounded earth with a grounding stake or screwdriver. Do not connect to common ground such as a metal water pipe or the pedestal ground as they can cause cancellation of the reflected signal or produce false locating signals.

The red lead is attached to the cable or metallic pipe in the following manner:

1. Non-energized Electrical Wires: Attach the red alligator clip lead to wires.
2. CATV Coax: Attach the red lead to the shield. This avoids signal disruption.
3. Telephone Drops: Attach red lead to sheath. This avoids signal disruption.
4. Irrigation Controller Wires: Attach the red lead to common wire or station wire.
5. Gas Pipes with Pilot Wire: Attach the red lead to pilot wire.
6. Metallic Pipes: Attach red lead to pipe.

Then turn thumb wheel switch to high tone. swing the antenna from the receiver over the ground and swing it back and forth. There is an obvious and easily heard humming sound when the antenna is on either near side of the wire (2-5cm away from the above wire). The tone would become high-pitched if the antenna is directly above the wire or far away from the wire. Proceed along the path following the “null” direction. This takes 80% skill and patience, 20% science and theory.

C. Measuring Depth

Once the path has been determined, mark the ground at a null point along the path. Hold the receiver antenna at a 45-degree angle to the ground and move at a right angle away from the path of the wire until another null is found. Mark this point. The distance between the two marks is the approximate depth of the wire. (Fig.01)

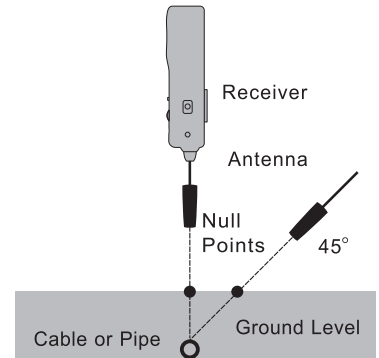

Fig • 01-Measuring Depth

D. Tracking Behind Walls

Hold the receiver in one hand and the antenna in the other. Position the antenna flat along the wall and at a right angle to the wire, approximately five feet away from the transmitter. Gently sweep around the subject area until a PEAK signal is found. Follow the PEAK signal to track the path of the wire.

Peak signal will become weaker as the antenna gets further away from the path of the wire. Adjust the receiver gain first, then if necessary, also adjust the transmitter output for best results.

(Fig.02)

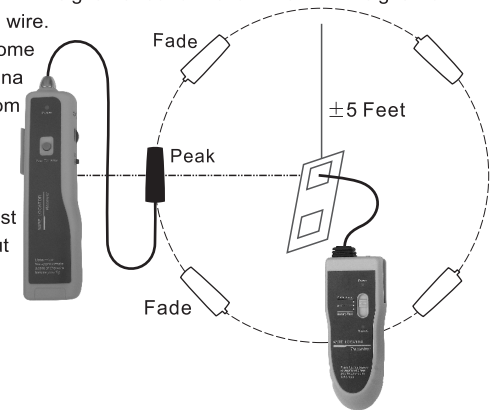

E. Locating Circuit Breakers

(Light Commercial & Residential Applications)

To locate the circuit breaker for a specific outlet, the hookup procedure is the same. Proceed to the breaker box and remove the panel so the wires leading into the breakers are exposed and turn the receiver on the high tone.

NOTE: Due to varying installation techniques, the signal might be strong on more than one wire on the same phase and AC interference or computer data buzz may be present. Scan each breaker wire by pointing the antenna at the wires.

The wire in question will have a distinct NULL (absence of tone) when the antenna tip is on the subject wire with tone on either side. (Fig.03)

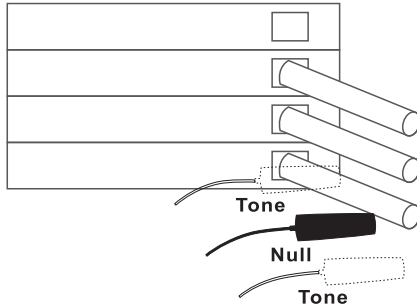

Fig • 03-Locating Circuit Breakers

Check signal strength on each subject wire by sliding the antenna in and out along each side of these wires. The loudest signal will be received

when the wire is received approximately one inch from the tip of the antenna. Choose the loudest, clearest conductor and with the antenna still held against the suspect wire, turn the breaker off. The signal will cease, positively identifying that breaker. (Fig.04)

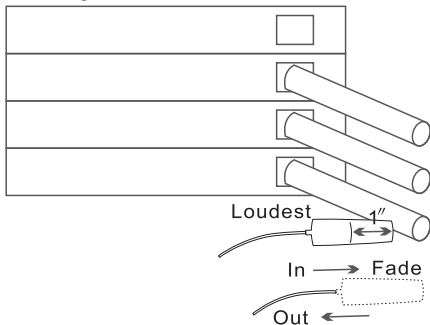

Fig • 04-Locating Circuit Breakers

CAUTION: DO NOT TURN OFF BREAKER IF CONNECTED TO EQUIPMENT THAT CANNOT BE INTERRUPTED.

To identify the phase feeding the breaker in question, scan all phases entering the breaker box.

Tone will be heard along the sides of the phase carrying the signal with a null directly over it. (Fig.05)

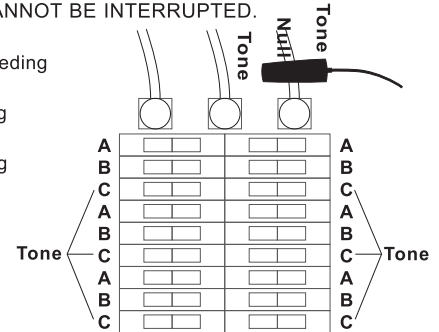

Fig • 05-Identifying The Phase

F. Pinpointing Drill Sites

Set up the transmitter as described in Figure 01 and attach to the nearest receptacle. Locate and mark the path of any signal near your drill site. If you have reason to believe that other installations are present near your drill site, use procedures outlined in Section 2C, Locating and Tracking Buried Wires.

The signal generated by the transmitter can be detected through walls and ceilings.

To pinpoint the transmitter's location (specific point), wrap the alligator clip leads around the transmitter, short the leads together, turn transmitter on and secure it to the opposite side of the wall or ceiling with tape. Scan the wall with the antenna flat against the wall. The peak signal will be heard when the antenna passes directly over the transmitter location. (Fig.06)

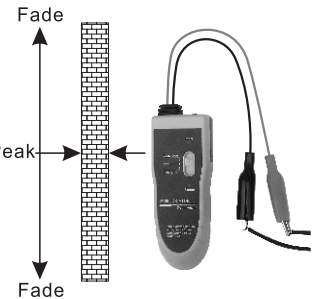

Fig • 06-Pinpointing Drill Sites

G. Determining Which Receptacles are on Specific Circuits

Set up transmitter as outlined in Figure 01 and radius adjacent outlets with antenna. You will have a tone at the receptacle/outlet if it is in the circuit. If a clear signal is not received, that outlet is not part of the circuit you are detecting.

H. Locating Alarm, Sound & Computer Wires

To locate other wires, it is best to disconnect the wire in question and directly attach only one transmitter lead to the subject wire, letting the other lead hang. Trace the path as outlined in, then trace the part of wire.

I. External Earphone

User can connect a 3.5mm earphone to the Receiver Earphone Jack Under noisy environment to improve the operating efficiency.(Fig.07)



Fig • 07

J. Locating Hidden Receptacles

To locate receptacles that have been covered up by drywall, attach one transmitter lead to the wire at the breaker and let the other lead hang. Scan the walls in the room with the antenna flat against the wall following the path or peak signal. The signal will be lost or fade rapidly once the tone get closer to the end of the wire.

K. White LED Flash Light

User can activate LED flash light if user press the “Push To Lamp” button.(Fig.08)



Fig • 08

4. MAINTENANCE

The only field service required for maintaining proper operation is the periodic replacement of the batteries in the transmitter and receiver.

A. Battery Replacement



WARNING

Before opening the case, remove the test leads from the circuit and shut off the unit. Failure to observe these warnings can result in severe injury or death.

Power Charging for lithium battery (only for F02 Pro)

The power supply for transmitter and receiver are both 3.7V Rechargeable battery. When finishing charging, the transmitter can work continuously for over 4hs, receiver can work for 7hs. The rechargeable battery avoids the trouble of replacing 9V battery again and again.

F02 Pro Transmitter

When charging for the battery, the CHG indicator turns red. If fully charged, the indicator will turn green. When low battery(<3.5V), the light will flash.

F02 Pro Receiver

When charging for the battery, the CHG indicator turns on. If fully charged, the indicator will be off. When operating the receiver, low battery(<3.5V), the indicator will turn on.

B. Cleaning

Periodically wipe with a damp cloth and mild detergent; do not use abrasives or solvents.

C. Service

Should you need for any reason to return the tester for repair or replacement take prior agreements with the local distributor from whom you purchased the item. Use only original packaging for any transit of shipment. The manufacturer will not be responsible for any damage to persons or things.

End of life



Caution:

This symbol indicates the equipment and its accessories shall be subject to a separate collection and correct disposal.

KOLSOL®
www.kolsol.net