

Drop Ins

**8100-EFP, N8000, N8000N, N8000-R, N8100BP,
N8100-BRP, N8100-FAP, N8200P, N8200GP, N8200-
STP, N8600P, N8700-D, N8700-DESP, N8700-R, N8800
Cold Pans & Hot Food Wells**

Original Instructions Installation, Operation and Maintenance Manual

This manual is updated as new information and models are released. Visit our website for the latest manual.



⚠ Caution

Read this instruction before operating this equipment.

Original Document

Part Number 9291458D 02/24

Safety Notices

⚠ Warning

Read this manual thoroughly before operating, installing or performing maintenance on the equipment. Failure to follow instructions in this manual can cause property damage, injury or death.

⚠ DANGER

Keep power cord AWAY from HEATED surfaces. DO NOT immerse power cord or plug in water. DO NOT let power cord hang over edge of table or counter.

⚠ DANGER

Do not lift the condensing unit by the refrigerant tubing or other components. These features will not support the condensing unit weight. Injury and unit damage may occur!

⚠ DANGER

Do not install or operate equipment that has been misused, abused, neglected, damaged, or altered/modified from that of original manufactured specifications.

⚠ DANGER

All utility connections and fixtures must be maintained in accordance with Local and national codes.

⚠ Warning

This appliance is not intended for use by persons (including children) with reduced physical, sensory or mental capabilities, or lack of experience and knowledge, unless they have been given supervision concerning use of the appliance by a person responsible for their safety. Do not allow children to play with this appliance.

⚠ Warning

Do not store or use gasoline or other flammable vapors or liquids inside or within the vicinity of this or any other appliance. Never use flammable oil soaked cloths or combustible cleaning solutions, for cleaning.

⚠ Warning

Authorized Service Representatives are obligated to follow industry standard safety procedures, including, but not limited to, local/national regulations for disconnection / lock out / tag out procedures for all utilities including electric, gas, water and steam.

⚠ Warning

This product contains chemicals known to the State of California to cause cancer and/or birth defects or other reproductive harm. Operation, installation, and servicing of this product could expose you to airborne particles of glasswool or ceramic fibers, crystalline silica, and/or carbon monoxide. Inhalation of airborne particles of glasswool or ceramic fibers is known to the State of California to cause cancer. Inhalation of carbon monoxide is known to the State of California to cause birth defects or other reproductive harm.

⚠ Warning

Do not use electrical appliances inside the food storage compartments of the appliance, unless they are of the type recommended by the manufacturer.

⚠ Warning

Use caution when handling metal surface edges of all equipment.

⚠ Warning

DO NOT touch refrigeration lines inside units; some may exceed temperatures of 200°F (93.3°C).

Note

Proper installation, care and maintenance are essential for maximum performance and trouble-free operation of your equipment. Visit our website www.wbtkitchencare.com for manual updates, translations, or contact information for service agents in your area.

Notice

Climatic class 4 is defined as ambient conditions of 30°C and 55% relative humidity, according to ISO 23953-2.

Note

These appliances are intended to be used for commercial applications, for example in kitchens of restaurants, canteens, hospitals and in commercial enterprises such as bakeries, butcheries, etc., but not for continuous mass production of food.

Notice

Climatic class 4 is defined as ambient conditions of 30°C and 55% relative humidity, according to ISO 23953-2.

Note

These appliances are intended for commercial/industrial use only. They are not intended for household use.

Notice

This product utilizes Ecomate blowing agent methyl formate

Notice

These units are intended to hold previously cooked product at a food safe temperature during time of serving. This product is **NOT** intended for cooking or increasing the temperature of held product. Improper use of unit may result in shorter unit lifespan.

Table of Contents

Section 1 General Information

Model Numbers	5
Serial Number Location	6
Warranty Information	6
Regulatory Certifications	6
Domestic Models.....	6
Export Models	6

Section 2 Installation

Location	8
Weight Of Equipment	8
Dimensions	10
Clearance Requirements	12
Cutout Installation Dimensions	13
Curved Drop-In Cutout Details.....	16
Drop-In Counter Installation	17
Ice Cooled Drop-In Units	17
8100P Series Self-Contained Refrigerated Drop-In Units	18
8100P Series Forced-Air Refrigerated Drop-In Units	22
8200P Series Self-Contained Refrigerated Drop-In Units.....	24
8600P Self-Contained Combo Hot/Cold Drop-In Units	26
8700 Hot Food Well Drop-In Units	28
Electrical Service	29
Voltage	29
Ground Fault Circuit Interrupter	29
Rated Amperages, Horsepower, Voltage & Power Cord Chart.....	29
Refrigeration	31
Optional Auto Fill Installation	32
Applicable to N8600 & N8800 Models	32
Applicable to N8700 Models.....	32

Section 3 Operation

Product Quality in Cold Pans	34
8100-EF(N)P Series Operation	35
Temperature Control & Display	35
Changing Display from Fahrenheit to Celsius on ERC112 Control	36
N8100BP, N8100-BRP & N8100NBP Operation	37
N8100-FAP Operation	38
N8200P & N8200-STP Operation	38
Operation N8200GP	38
8600P Hot/Cold Series Operation	39
N8700-D, N8700N, N8700-R & N8800 Series Operation	40
N8700-DESP Operation	41



**Section 4
Maintenance**

Cleaning and Sanitizing Procedures.....42
 General..... 42
 Exterior Cleaning..... 43
 Cleaning the Condenser Coil 43
 N8100-FA Series Drain Maintenance..... 43



Section 1

General Information

Model Numbers

8100-EFP Series		
LiquiTec® Eutetic Fluid Refrigerated Cold Pans - R290		
8118-EFP	8132-EFP	8145-EFP
8159-EFP	8172-EFP	8186-EFP
8100-EF-E Export Series		
LiquiTec® Eutetic Fluid Refrigerated Cold Pans - R404A		
8118-EF-E	8132-EF-E	8145-EF-E
8159-EF-E	8172-EF-E	8186-EF-E
8100-EFNP Series		
LiquiTec® Slim Line Eutetic Fluid Refrigerated Cold Pans - R290		
8148-EFNP	8169-EFNP	8191-EFNP
8100-EFN-E Export Series		
LiquiTec® Slim Line Eutetic Fluid Refrigerated Cold Pans - R404A		
8148-EFN-E	8169-EFN-E	8191-EFN-E
N8000 Series		
Ice Cooled Cold Pans		
N8018	N8030	N8043
N8056	N8069	N8081
N8000N Series		
Narrow Ice Cooled Cold Pans		
N8046N	N8068N	
N8000-R Series		
Curved Ice Cooled Cold Pans		
N8044-R	N8059-R	N8076-R
N8094-R		
N8100BP Series		
Self-Contained Mechanically Cooled Pans - R290		
N8118BP	N8130BP	N8143BP
N8156BP	N8169BP	N8181BP
N8100B-E Export Series		
Self-Contained Mechanically Cooled Pans - R404A		
N8118B-E	N8130B-E	N8143B-E
N8100B-E Export Series		
Self-Contained Mechanically Cooled Pans - R134A		
N8156B-E	N8169B-E	
N8100BRP Series		
Curved Self-Contained Mechanically Cooled Pans - R290		
N8144-BRP	N8159-BRP	N8176-BRP
N8194-BRP		
N8100-FAP Series		
Forced Air Drop-In Mechanically Cooled Cold Pans - R290		
N8131-FAP	N8144-FAP	N8157-FAP
N8169-FAP	N8182-FAP	
N8100NBP Series		
Self-Contained Mechanically Cooled Pans Narrow Style - R290		
N8146NBP	N8168NBP	
N8100NB-E Export Series		
Self-Contained Mechanically Cooled Pans Narrow Style - R404A		
N8146NB-E	N8168NB-E	

N8200P Series		
Self-Contained Frost Tops - R290		
N8231P	N8245P	N8259P
N8273P	N8287P	
N8200-E Export Series		
Self-Contained Frost Tops - R404A		
N8231-E	N8245-E	N8259-E
N8273-E	N8287-E	
N8200GP Series		
Self-Contained Granite Cold Slabs - R290		
N8231GP	N8245GP	N8259GP
N8273GP		
N8200G-E Export Series		
Self-Contained Granite Cold Slabs - R404A		
N8231G-E	N8245G-E	N8259G-E
N8200-STP Series		
Self-Contained Frost Tops - R290		
N8230-STP	N8240-STP	N8256-STP
N8258-STP	N8275-STP	
N8600P Series		
Self Contained Combination Hot/Cold Food Wells - R290		
N8630P	N8643P	N8656P
N8669P	N8681P	
N8700D Series		
Individually Controlled Heated Food Wells		
N8717-D	N8731-D	N8745-D
N8759-D	N8773-D	N8787-D
N8700D-E Export Series		
Individually Controlled Heated Food Wells		
N8717-D-E	N8731-D-E	N8745-D-E
N8759-D-E	N8773-D-E	N8787-D-E
N8700DESP Series		
Individually Controlled Energy Savings Heated Food Wells		
N8717-DESP	N8731-DESP	N8745-DESP
N8759-DESP	N8773-DESP	N8787-DESP
N8700-D-ESP-E Export Series		
Individually Controlled Energy Savings Heated Food Wells		
N8717-D-ESP-E	N8731-D-ESP-E	N8745-D-ESP-E
N8759-D-ESP-E	N8773-D-ESP-E	N8787-D-ESP-E
N8700N Series		
Individually Controlled Heated Narrow Food Wells		
N8746ND	N8768N	N8768ND
N8700-R Series		
Curved Individually Controlled Heated Food Wells		
N8744-R	N8759-R	N8776-R
N8794-R		
N8800 Series		
Single Tank Electric Hot Food Wells		
N8831	N8845	N8859
N8873	N8887	
N8800-E Export Series		
Single Tank Electric Hot Food Wells		
N8831-E	N8845-E	N8859-E
N8873-E	N8887-E	

† Drop-In FlexiWell & FlexiTop Models N8600-FWP and N8200-FTP are within the FlexiWell manual 9291544



Serial Number Location

The serial number is listed on the serial tag. If applicable it will also list the refrigerant used and the amount of charge.

- The serial tag on self-contained refrigerated units is located near the condensing unit.
- The serial tag on ice cooled units and remote refrigerated units is on the outside bottom of the food well.
- On hot food pans and hot/cold combination pans, the serial tag is located on the back of the control raceway or remote panel.

Always have the serial number of your unit available when calling for parts or service.

Warranty Information

- Register your product for warranty,
- Verify warranty information,
- View and download a copy of your warranty, at www.delfield.com/warranty

Service

For parts and service consult Welbilt KitchenCare at 1-844-724-CARE



Regulatory Certifications

DOMESTIC MODELS

All domestic models are certified by:



-  National Sanitation Foundation (NSF)

All domestic electrical models are certified by:

-  Underwriters Laboratories (UL)
-  Underwriters Laboratories of Canada (cUL)

EXPORT MODELS

230-240Volt, 50Hertz, 1Phase models are certified by:

-  National Sanitation Foundation (NSF)
-  Technical Inspection Association
-  European Conformity

Section 2 Installation

DANGER

Installation must comply with all applicable fire and health codes in your jurisdiction.

DANGER

Use appropriate safety equipment during installation and servicing.

Warning

Remove all removable panels before lifting and installing.

Warning

If a refrigerated base does not have a condensate evaporator supplied, you must connect the condensate line to a suitable drain. Otherwise, water will collect on the floor, causing a potentially hazardous situation.

Warning

Moisture collecting from improper drainage can create a slippery surface on the floor and a hazard to employees. It is the owner's responsibility to provide a container or outlet for drainage.

Warning

Do not damage the refrigeration circuit when installing, maintaining or servicing the unit.

Warning

This equipment must be positioned so that the plug is accessible unless other means for disconnection from the power supply (e.g., circuit breaker or disconnect switch) is provided.

Warning

Adequate means must be provided to limit the movement of this appliance without depending on or transmitting stress to the electrical conduit.

Warning

To avoid instability the installation area must be capable of supporting the combined weight of the equipment and product. Additionally the equipment must be level side to side and front to back.

Warning

This equipment is intended for indoor use only. Do not install or operate this equipment in outdoor areas.

Caution

The units with LiquiTec technology cold pans contain a non-toxic eutectic fluid within a sealed inner liner. This fluid may leak if the tank is punctured so care must be taken when uncrating and setting in place. The eutectic fluid is non-toxic and may be flushed down a disposal drain. Units with a Eutectic Fluid Cold Pan require the same precautions. The fluid is NOT refillable and loss of fluid due to a puncture would cause irreparable damage. If the LiquiTec unit cold pans leak, immediately call the Delfield service department directly at 1-800-733-8821 not your local service agent.

Caution

Do not position the air intake vent near steam or heat exhaust of another appliance.

Note

This symbol indicates the location of the equipotential bonding conductor connection.



Note

This symbol indicates a hot surface that can cause injury to persons..



Location

The location selected for the equipment must meet the following criteria. If any of these criteria are not met, select another location.

- Units are intended for indoor use only.
- The location MUST be level, stable and capable of supporting the weight of the equipment.
- The location MUST be free from and clear of combustibile materials.
- Equipment MUST be level both front to back and side to side.
- Position the equipment so it will not tip or slide.
- Recommended air temperature is 41° - 86°F (5° - 30°C).
- Proper air supply for ventilation is REQUIRED AND CRITICAL for safe and efficient operation. Refer to Clearance Requirements chart on page 13.
- Do not obstruct the flow of ventilation air. Make sure the air vents of the equipment are not blocked.
- Do not install the equipment directly over a drain. Steam rising up out of the drain will adversely affect operation, air circulation, and damage electrical / electronic components.

Weight Of Equipment

Model	Ship Weight
8100-EFP Series	
8118-EFP	169lbs (77kg)
8132-EFP	215lbs (98kg)
8145-EFP	265lbs (120kg)
8159-EFP	285lbs (130kg)
8172-EFP	295lbs (134kg)
8186-EFP	394lbs (179kg)
8100-EF-E Export Series	
8118-EF-E	169lbs (77kg)
8132-EF-E	215lbs (98kg)
8145-EF-E	265lbs (120kg)
8159-EF-E	285lbs (130kg)
8172-EF-E	295lbs (134kg)
8186-EF-E	394lbs (179kg)
8100-EFNP Series	
8148-EFNP	235lbs (107kg)
8169-EFNP	285lbs (130kg)
8191-EFNP	295lbs (134kg)
8100-EFN-E Export Series	
8148-EFN-E	235lbs (107kg)
8169-EFN-E	285lbs (130kg)
8191-EFN-E	295lbs (134kg)
N8000 Series	
N8018	38lbs (17kg)
N8030	84lbs (38kg)
N8043	110lbs (50kg)
N8056	139lbs (63kg)
N8069	160lbs (73kg)
N8081	197lbs (89kg)
N8000N Series	
N8046N	100lbs (45kg)
N8068N	120lbs (55kg)
N8000-R Series	
N8044-R	100lbs (45kg)
N8059-R	118lbs (53kg)
N8076-R	145lbs (65kg)
N8094-R	164lbs (74kg)
N8100BP Series	
N8118BP	100lbs (45kg)
N8130BP	140lbs (64kg)
N8143BP	173lbs (78kg)
N8156BP	205lbs (93kg)
N8169BP	225lbs (102kg)
N8181BP	258lbs (117kg)
N8100B-E Export Series - R404A	
N8118B-E	100lbs (45kg)
N8130B-E	140lbs (64kg)
N8143B-E	173lbs (78kg)
N8100B-E Export Series - R134A	
N8156B-E	205lbs (93kg)
N8169B-E	225lbs (102kg)
N8100BRP Series	
N8144-BRP	161lbs (72kg)
N8159-BRP	184lbs (83kg)
N8176-BRP	233lbs (105kg)
N8194-BRP	243lbs (109kg)



Model	Ship Weight
N8100-FAP Series	
N8131-FAP	168lbs (76kg)
N8144-FAP	175lbs (79kg)
N8157-FAP	225lbs (102kg)
N8169-FAP	235lbs (107kg)
N8182-FAP	406lbs (184kg)
N8100NBP Series	
N8146NBP	175lbs (80kg)
N8168NBP	240lbs (109kg)
N8100NB-E Export Series	
N8146NB-E	175lbs (80kg)
N8168NB-E	240lbs (109kg)
N8200P Series	
N8231P	142lbs (64kg)
N8245P	168lbs (76kg)
N8259P	193lbs (88kg)
N8273P	209lbs (95kg)
N8287P	239lbs (108kg)
N8200-E Export Series	
N8231-E	142lbs (64kg)
N8245-E	168lbs (76kg)
N8259-E	193lbs (88kg)
N8273-E	209lbs (95kg)
N8287-E	239lbs (108kg)
N8200GP Series	
N8231GP	219lbs (99kg)
N8245GP	284lbs (129kg)
N8259GP	338lbs (153kg)
N8273GP	425lbs (193kg)
N8200G-E Export Series	
N8231G-E	219lbs (99kg)
N8245G-E	284lbs (129kg)
N8259G-E	338lbs (153kg)
N8200-STP Series	
N8230-STP	142lbs (64kg)
N8240-STP	168lbs (76kg)
N8256-STP	193lbs (88kg)
N8258-STP	209lbs (95kg)
N8275-STP	239lbs (108kg)
N8600P Series	
N8630P	164lbs (74kg)
N8643P	198lbs (90kg)
N8656P	233lbs (106kg)
N8669P	266lbs (121kg)
N8681P	301lbs (137kg)
N8700D Series	
N8717-D	41lbs (19kg)
N8731-D	99lbs (45kg)
N8745-D	134lbs (61kg)
N8759-D	166lbs (75kg)
N8773-D	186lbs (84kg)
N8787-D	236lbs (107kg)
N8700D-E Export Series	
N8717-D-E	41lbs (19kg)
N8731-D-E	99lbs (45kg)
N8745-D-E	134lbs (61kg)
N8759-D-E	166lbs (75kg)
N8773-D-E	186lbs (84kg)
N8787-D-E	236lbs (107kg)

Model	Ship Weight
N8700DESP Series	
N8717-DESP	41lbs (19kg)
N8731-DESP	99lbs (45kg)
N8745-DESP	134lbs (61kg)
N8759-DESP	166lbs (75kg)
N8773-DESP	186lbs (84kg)
N8787-DESP	236lbs (107kg)
N8700-D-ESP-E Export Series	
N8717-D-ESP-E	41lbs (19kg)
N8731-D-ESP-E	99lbs (45kg)
N8745-D-ESP-E	134lbs (61kg)
N8759-D-ESP-E	166lbs (75kg)
N8773-D-ESP-E	186lbs (84kg)
N8787-D-ESP-E	236lbs (107kg)
N8700N Series	
N8746ND	100lbs (45kg)
N8768N	130lbs (59kg)
N8768ND	130lbs (59kg)
N8700-R Series	
N8744-R	99lbs (45kg)
N8759-R	134lbs (61kg)
N8776-R	166lbs (75kg)
N8794-R	186lbs (84kg)
N8800 Series	
N8831	100lbs (45kg)
N8845	136lbs (62kg)
N8859	158lbs (72kg)
N8873	195lbs (88kg)
N8887	224lbs (102kg)
N8800-E Export Series	
N8831-E	100lbs (45kg)
N8845-E	136lbs (62kg)
N8859-E	158lbs (72kg)
N8873-E	195lbs (88kg)
N8887-E	224lbs (102kg)

† Drop-In FlexiWell & FlexiTop Models N8600-FWP and N8200-FTP are within the FlexiWell manual 9291544



Dimensions

Model	Length	Depth	Height	12x20 Pans
8100-EFP Series				
8118-EFP	18.20" (46cm)	26" (66cm)	23.25" (59cm)	1
8132-EFP	31.76" (81cm)	26" (66cm)	23.25" (59cm)	2
8145-EFP	45.32" (115cm)	26" (66cm)	23.25" (59cm)	3
8159-EFP	58.88" (150cm)	26" (66cm)	23.25" (59cm)	4
8172-EFP	72.44" (184cm)	26" (66cm)	23.25" (59cm)	5
8186-EFP	86" (218cm)	26" (66cm)	23.25" (59cm)	6
8100-EF-E Export Series				
8118-EF-E	18.20" (46cm)	26" (66cm)	23.25" (59cm)	1
8132-EF-E	31.76" (81cm)	26" (66cm)	23.25" (59cm)	2
8145-EF-E	45.32" (115cm)	26" (66cm)	23.25" (59cm)	3
8159-EF-E	58.88" (150cm)	26" (66cm)	23.25" (59cm)	4
8172-EF-E	72.44" (184cm)	26" (66cm)	23.25" (59cm)	5
8186-EF-E	86" (218cm)	26" (66cm)	23.25" (59cm)	6
8100-EFNP Series				
8148-EFNP	47.66" (121cm)	18" (46cm)	23.25" (59cm)	2
8169-EFNP	69.22" (176cm)	18" (46cm)	23.25" (59cm)	3
8191-EFNP	90.78" (231cm)	18" (46cm)	23.25" (59cm)	4
8100-EFN-E Export Series				
8148-EFN-E	47.66" (121cm)	18" (46cm)	23.25" (59cm)	2
8169-EFN-E	69.22" (176cm)	18" (46cm)	23.25" (59cm)	3
8191-EFN-E	90.78" (231cm)	18" (46cm)	23.25" (59cm)	4
N8000 Series				
N8018	18" (46cm)	26" (66cm)	10.75" (27cm)	1
N8030	30.75" (78cm)	26" (66cm)	10.75" (27cm)	2
N8043	43.5" (110cm)	26" (66cm)	10.75" (27cm)	3
N8056	56.25" (143cm)	26" (66cm)	10.75" (27cm)	4
N8069	69" (175cm)	26" (66cm)	10.75" (27cm)	5
N8081	81.75" (208cm)	26" (66cm)	10.75" (27cm)	6

Model	Length	Depth	Height	12x20 Pans
N8000N Series				
N8046N	46.75" (119cm)	18" (46cm)	10.75" (27cm)	2
N8068N	67.5" (171cm)	18" (46cm)	10.75" (27cm)	3
N8000-R Series				
N8044-R	40.48" (103cm)	26.05" (66cm)	10.77" (27cm)	2
N8059-R	57.22" (145cm)	26.05" (66cm)	10.77" (27cm)	3
N8076-R	73.68" (187cm)	26.05" (66cm)	10.77" (27cm)	4
N8094-R	89.89" (228cm)	26.05" (66cm)	10.77" (27cm)	5
N8100B Series				
N8118B	18" (46cm)	26" (66cm)	21.87" (56cm)	1
N8130B	30.75" (78cm)	26" (66cm)	21.87" (56cm)	2
N8143B	43.5" (110cm)	26" (66cm)	21.87" (56cm)	3
N8156B	56.25" (143cm)	26" (66cm)	21.87" (56cm)	4
N8169B	69" (175cm)	26" (66cm)	21.87" (56cm)	5
N8181B	81.75" (208cm)	26" (66cm)	21.87" (56cm)	6
N8100B-E Export Series - R404A				
N8118B-E	18" (46cm)	26" (66cm)	21.87" (56cm)	1
N8130B-E	30.75" (78cm)	26" (66cm)	21.87" (56cm)	2
N8143B-E	43.5" (110cm)	26" (66cm)	21.87" (56cm)	3
N8100B-E Export Series - R134A				
N8156B-E	56.25" (143cm)	26" (66cm)	21.87" (56cm)	4
N8169B-E	69" (175cm)	26" (66cm)	21.87" (56cm)	5
N8100BRP Series				
N8144-BRP	40.43" (103cm)	26.05" (66cm)	21.81" (55cm)	2
N8159-BRP	57.22" (145cm)	26.05" (66cm)	21.81" (55cm)	3
N8176-BRP	73.68" (187cm)	26.05" (66cm)	21.81" (55cm)	4
N8194-BRP	89.86" (228cm)	26.05" (66cm)	21.81" (55cm)	5
N8100-FAP Series				
N8131-FAP	31.25" (79cm)	26.67" (68cm)	26.62" (68cm)	2
N8144-FAP	44" (112cm)	26.67" (68cm)	26.62" (68cm)	3
N8157-FAP	56.75" (144cm)	26.67" (68cm)	26.62" (68cm)	4
N8169-FAP	69.5" (177cm)	26.67" (68cm)	28.62" (73cm)	5
N8182-FAP	82.25" (209cm)	26.67" (68cm)	28.62" (73cm)	6



Model	Length	Depth	Height	12x20 Pans
N8100NBP Series				
N8146NBP	46.75" (119cm)	18" (46cm)	21.81" (55cm)	2
N8168NBP	67.5" (171cm)	18" (46cm)	21.81" (55cm)	3
N8100NB-E Export Series				
N8146NB-E	46.75" (119cm)	18" (46cm)	21.81" (55cm)	2
N8168NB-E	67.5" (171cm)	18" (46cm)	21.81" (55cm)	3
N8200P Series				
N8231P	31.75" (81cm)	26" (66cm)	15.75" (40cm)	NA
N8245P	45.63" (116cm)	26" (66cm)	15.75" (40cm)	NA
N8259P	59.5" (151cm)	26" (66cm)	15.75" (40cm)	NA
N8273P	73.38" (186cm)	26" (66cm)	15.75" (40cm)	NA
N8287P	87.25" (222cm)	26" (66cm)	15.75" (40cm)	NA
N8200-E Export Series				
N8231-E	31.75" (81cm)	26" (66cm)	15.75" (40cm)	NA
N8245-E	45.63" (116cm)	26" (66cm)	15.75" (40cm)	NA
N8259-E	59.5" (151cm)	26" (66cm)	15.75" (40cm)	NA
N8273-E	73.38" (186cm)	26" (66cm)	15.75" (40cm)	NA
N8287-E	87.25" (222cm)	26" (66cm)	15.75" (40cm)	NA
N8200GP Series				
N8231GP	31.75" (81cm)	25.87" (66cm)	19" (48cm)	NA
N8245GP	45.63" (116cm)	25.87" (66cm)	19" (48cm)	NA
N8259GP	59.5" (151cm)	25.87" (66cm)	19" (48cm)	NA
N8273GP	73.38" (186cm)	25.87" (66cm)	19" (48cm)	NA
N8200G-E Export Series				
N8231G-E	31.75" (81cm)	25.87" (66cm)	19" (48cm)	NA
N8245G-E	45.63" (116cm)	25.87" (66cm)	19" (48cm)	NA
N8259G-E	59.5" (151cm)	25.87" (66cm)	19" (48cm)	NA
N8200-STP Series				
N8230-STP	29.60" (75cm)	22" (56cm)	15.70" (40cm)	NA
N8240-STP	39.70" (101cm)	29.60" (75cm)	15.70" (40cm)	NA
N8256-STP	55.60" (141cm)	22" (56cm)	15.70" (40cm)	NA
N8258-STP	57.60" (146cm)	29.60" (75cm)	15.70" (40cm)	NA
N8275-STP	75.50" (192cm)	29.60" (75cm)	15.70" (40cm)	NA

Model	Length	Depth	Height	12x20 Pans
N8600P Series				
N8630P	30.75" (78cm)	26" (66cm)	23.75" (60cm)	2
N8643P	43.5" (110cm)	26" (66cm)	23.75" (60cm)	3
N8656P	56.25" (143cm)	26" (66cm)	23.75" (60cm)	4
N8669P	69" (175cm)	26" (66cm)	23.75" (60cm)	5
N8681P	81.75" (208cm)	26" (66cm)	23.75" (60cm)	6
N8700D Series				
N8717-D	17.88" (45cm)	26" (66cm)	9.5" (24cm)*	1
N8731-D	31.75" (81cm)	26" (66cm)	9.5" (24cm)*	2
N8745-D	45.63" (116cm)	26" (66cm)	9.5" (24cm)*	3
N8759-D	59.5" (151cm)	26" (66cm)	9.5" (24cm)*	4
N8773-D	73.38" (186cm)	26" (66cm)	9.5" (24cm)*	5
N8787-D	87.25" (222cm)	26" (66cm)	9.5" (24cm)*	6
*14" Overall height including drain connection				
N8700D-E Export Series				
N8717-D-E	17.88" (45cm)	26" (66cm)	9.5" (24cm)*	1
N8731-D-E	31.75" (81cm)	26" (66cm)	9.5" (24cm)*	2
N8745-D-E	45.63" (116cm)	26" (66cm)	9.5" (24cm)*	3
N8759-D-E	59.5" (151cm)	26" (66cm)	9.5" (24cm)*	4
N8773-D-E	73.38" (186cm)	26" (66cm)	9.5" (24cm)*	5
N8787-D-E	87.25" (222cm)	26" (66cm)	9.5" (24cm)*	6
*14" Overall height including drain connection				
N8700DESP Series				
N8717-DESP	17.89" (45cm)	26" (66cm)	9.5" (24cm)*	1
N8731-DESP	31.76" (81cm)	26" (66cm)	9.5" (24cm)*	2
N8745-DESP	45.63" (116cm)	26" (66cm)	9.5" (24cm)*	3
N8759-DESP	59.50" (151cm)	26" (66cm)	9.5" (24cm)*	4
N8773-DESP	73.37" (186cm)	26" (66cm)	9.5" (24cm)*	5
N8787-DESP	87.24" (222cm)	26" (66cm)	9.5" (24cm)*	6
*14" Overall height including drain connection				



Model	Length	Depth	Height	12x20 Pans
N8700-D-ESP-E Export Series				
N8717-D-ESP-E	17.89" (45cm)	26" (66cm)	9.5" (24cm)*	1
N8731-D-ESP-E	31.76" (81cm)	26" (66cm)	9.5" (24cm)*	2
N8745-D-ESP-E	45.63" (116cm)	26" (66cm)	9.5" (24cm)*	3
N8759-D-ESP-E	59.50" (151cm)	26" (66cm)	9.5" (24cm)*	4
N8773-D-ESP-E	73.37" (186cm)	26" (66cm)	9.5" (24cm)*	5
N8787-D-ESP-E	87.24" (222cm)	26" (66cm)	9.5" (24cm)*	6
*14" Overall height including drain connection				
N8700N Series				
N8746ND	45.61" (116cm)	15.87" (40cm)	9.5" (24cm)*	2
N8768N	67.48" (172cm)	15.87" (40cm)	9.5" (24cm)*	3
N8768ND	67.48" (172cm)	15.87" (40cm)	9.5" (24cm)*	3
N8700-R Series				
N8744-R	40.48" (103cm)	26.05" (66cm)	9.5" (24cm)*	2
N8759-R	57.22" (145cm)	26.05" (66cm)	9.5" (24cm)*	3
N8776-R	73.68" (187cm)	26" (66cm)	9.5" (24cm)*	4
N8794-R	89.80" (228cm)	25.91" (66cm)	9.5" (24cm)*	5
*14" Overall height including drain connection				
N8800 Series				
N8831	31.75" (81cm)	26" (66cm)	11" (28cm)	2
N8845	45.63" (116cm)	26" (66cm)	11" (28cm)	3
N8859	59.5" (151cm)	26" (66cm)	11" (28cm)	4
N8873	73.38" (186cm)	26" (66cm)	11" (28cm)	5
N8887	87.25" (222cm)	26" (66cm)	11" (28cm)	6
N8800-E Export Series				
N8831-E	31.75" (81cm)	26" (66cm)	11" (28cm)	2
N8845-E	45.63" (116cm)	26" (66cm)	11" (28cm)	3
N8859-E	59.5" (151cm)	26" (66cm)	11" (289cm)	4
N8873-E	73.38" (186cm)	26" (66cm)	11" (289cm)	5
N8887-E	87.25" (222cm)	26" (66cm)	11" (28cm)	6

† Drop-In FlexiWell & FlexiTop Models N8600-FWP and N8200-FTP are within the FlexiWell manual 9291544

Clearance Requirements

⚠ DANGER

Minimum clearance requirements are the same for noncombustible locations as for combustible locations. The flooring under the appliance must be made of a noncombustible material.

⚠ DANGER

Risk of fire/shock. All minimum clearances must be maintained. Do not obstruct vents or openings.

Heated & Combination Hot/Cold Food Wells Bottom & Side Clearance
3" (76mm)
Cooled Pans, Frost Tops & Granite Cold Slabs Clearance
0" (0cm)

- Keep the vents clean and free of obstruction.



Cutout Installation Dimensions

Model	Counter Cutout Dimensions	Control Panel Cutout Dimensions
8100-EFP Series		
8118-EFP	17" x 25" (43cm x 64cm)	NA
8132-EFP	30.75" x 25" (78cm x 64cm)	NA
8145-EFP	44.25" x 25" (112cm x 64cm)	NA
8159-EFP	57.87" x 25" (147cm x 64cm)	NA
8172-EFP	71.5" x 25" (182cm x 64cm)	NA
8186-EFP	85" x 25" (216cm x 64cm)	NA
8100-EF-E Export Series		
8118-EF-E	17" x 25" (43cm x 64cm)	NA
8132-EF-E	30.75" x 25" (78cm x 64cm)	NA
8145-EF-E	44.25" x 25" (112cm x 64cm)	NA
8159-EF-E	57.87" x 25" (147cm x 64cm)	NA
8172-EF-E	71.5" x 25" (182cm x 64cm)	NA
8186-EF-E	85" x 25" (216cm x 64cm)	NA
8100-EFNP Series		
8148-EFNP	46.88" x 17.25" (119cm x 44cm)	NA
8169-EFNP	68.5" x 17.25" (174cm x 44cm)	NA
8191-EFNP	90" x 17.25" (229cm x 44cm)	NA
8100-EFN-E Export Series		
8148-EFN-E	46.88" x 17.25" (119cm x 44cm)	NA
8169-EFN-E	68.5" x 17.25" (174cm x 44cm)	NA
8191-EFN-E	90" x 17.25" (229cm x 44cm)	NA
N8000 Series		
N8018	17" x 25" (43cm x 64cm)	NA
N8030	29.75" x 25" (76cm x 64cm)	NA
N8043	42.5" x 25" (108cm x 64cm)	NA
N8056	55.25" x 25" (140cm x 64cm)	NA
N8069	68" x 25" (173cm x 64cm)	NA
N8081	80.75" x 25" (205cm x 64cm)	NA

Model	Counter Cutout Dimensions	Control Panel Cutout Dimensions
N8000N Series		
N8046N	45.75" x 17" (116cm x 43cm)	NA
N8068N	66.50" x 17" (169cm x 43cm)	NA
N8000-R Series		
N8044-R	See drawing on page 17	NA
N8059-R	See drawing on page 17	NA
N8076-R	See drawing on page 17	NA
N8094-R	See drawing on page 17	NA
N8100BP Series		
N8118BP	17" X 25" (43cm x 64cm)	NA
N8130BP	29.75" x 25" (76cm x 64cm)	NA
N8143BP	42.50" X 25" (108cm x 64cm)	NA
N8156BP	55.25" x 25" (140cm x 64cm)	NA
N8169BP	68" X 25" (173cm x 64cm)	NA
N8181BP	80.75" x 25" (205cm x 64cm)	NA
N8100B-E Export Series - R404A		
N8118B-E	17" X 25" (43cm x 64cm)	NA
N8130B-E	29.75" x 25" (76cm x 64cm)	NA
N8143B-E	42.50" X 25" (108cm x 64cm)	NA
N8100B-E Export Series - R134A		
N8156B-E	55.25" x 25" (140cm x 64cm)	NA
N8169B-E	68" X 25" (173cm x 64cm)	NA
N8100-BRP Series		
N8144-BRP	See drawing on page 17	NA
N8159-BRP	See drawing on page 17	NA
N8176-BRP	See drawing on page 17	NA
N8194-BRP	See drawing on page 17	NA

Model	Counter Cutout Dimensions	Control Panel Cutout Dimensions
N8100FAP Series		
N8131-FAP	30.25" x 25.5" (77cm x 65cm)	NA
N8144-FAP	43" x 25.5" (109cm x 65cm)	NA
N8157-FAP	55.75" x 25.5" (142cm x 65cm)	NA
N8169-FAP	68.5" x 25.5" (174cm x 65cm)	NA
N8182-FAP	81.25" x 25.5" (206cm x 65cm)	NA
N8100NBP Series		
N8146NBP	45.75" x 17" (116cm x 43cm)	NA
N8168NBP	66.5" x 17" (169cm x 43cm)	NA
N8100NB-E Export Series		
N8146NB-E	45.75" x 17" (116cm x 43cm)	NA
N8168NB-E	66.5" x 17" (169cm x 43cm)	NA
N8200P Series		
N8231P	30.75" x 25" (78cm x 64cm)	NA
N8245P	44.63" x 25" (113cm x 64cm)	NA
N8259P	58.50" x 25" (149cm x 64cm)	NA
N8273P	72.38" x 25" (184cm x 64cm)	NA
N8287P	86.25" x 25" (219cm x 64cm)	NA
N8200-E Export Series		
N8231-E	30.75" x 25" (78cm x 64cm)	NA
N8245-E	44.63" x 25" (113cm x 64cm)	NA
N8259-E	58.50" x 25" (149cm x 64cm)	NA
N8273-E	72.38" x 25" (184cm x 64cm)	NA
N8287-E	86.25" x 25" (219cm x 64cm)	NA
N8200GP Series		
N8231GP	30.75" X 25" (78cm x 64cm)	NA
N8245GP	44.63" x 25" (113cm x 64cm)	NA
N8259GP	58.5" x 25" (149cm x 64cm)	NA
N8273GP	72.38" x 25" (184cm x 64cm)	NA

Model	Counter Cutout Dimensions	Control Panel Cutout Dimensions
N8200G-E Export Series		
N8231G-E	30.75" X 25" (78cm x 64cm)	NA
N8245G-E	44.63" x 25" (113cm x 64cm)	NA
N8259G-E	58.5" x 25" (149cm x 64cm)	NA
N8200-STP Series		
N8230-STP	28.60" x 21.10" (73cm x 54cm)	NA
N8240-STP	38.65" x 28.75" (98cm x 73cm)	NA
N8256-STP	54.60" x 21.10" (139cm x 54cm)	NA
N8258-STP	56.60" x 28.75" (144cm x 73cm)	NA
N8275-STP	74.50" x 28.75" (189cm x 73cm)	NA
N8600P Series		
N8630P	29.75" X 25" (76cm x 64cm)	12.25" x 4.25" x 7" (31cm x 11cm x 18cm)
N8643P	42.50" x 25" (108cm x 64cm)	12.25" x 4.25" x 7" (31cm x 11cm x 18cm)
N8656P	55.25" x 25" (140cm x 64cm)	12.25" x 4.25" x 7" (31cm x 11cm x 18cm)
N8669P	68" x 25" (173cm x 64cm)	12.25" x 4.25" x 7" (31cm x 11cm x 18cm)
N8681P	80.75" x 25" (205cm x 64cm)	12.25" x 4.25" x 7" (31cm x 11cm x 18cm)
N8700D Series		
N8717-D	16.88" X 25" (43cm x 64cm)	7" x 4.62" x 7" (18cm x 12cm x 18cm)
N8731-D	30.75" x 25" (78cm x 64cm)	10.31" x 4.62" x 7" (26cm x 12cm x 18cm)
N8745-D	44.62" x 25" (113cm x 64cm)	14.5" x 4.62" x 7" (37cm x 12cm x 18cm)
N8759-D	58.5" x 25" (149cm x 64cm)	18.69" x 4.62" x 7" (47cm x 12cm x 18cm)
N8773-D	72.37" x 25" (184cm x 64cm)	22.88" x 4.62" x 7" (58cm x 12cm x 18cm)
N8787-D	86.25" x 25" (219cm x 64cm)	27" x 4.62" x 7" (69cm x 12cm x 18cm)
N8700D-E Export Series		
N8717-D-E	16.88" X 25" (43cm x 64cm)	7" x 4.62" x 7" (18cm x 12cm x 18cm)
N8731-D-E	30.75" x 25" (78cm x 64cm)	10.31" x 4.62" x 7" (26cm x 12cm x 18cm)
N8745-D-E	44.62" x 25" (113cm x 64cm)	14.5" x 4.62" x 7" (37cm x 12cm x 18cm)
N8759-D-E	58.5" x 25" (149cm x 64cm)	18.69" x 4.62" x 7" (47cm x 12cm x 18cm)
N8773-D-E	72.37" x 25" (184cm x 64cm)	22.88" x 4.62" x 7" (58cm x 12cm x 18cm)
N8787-D-E	86.25" x 25" (219cm x 64cm)	27" x 4.62" x 7" (69cm x 12cm x 18cm)

Model	Counter Cutout Dimensions	Control Panel Cutout Dimensions
N8700DESP Series		
N8717-DESP	16.87" X 25" (43cm x 64cm)	5" x 6.88" x 7.50" (13cm x 17cm x 19cm)
N8731-DESP	30.75" x 25" (78cm x 64cm)	5" x 11.88" x 7.50" (13cm x 30cm x 19cm)
N8745-DESP	44.62" x 25" (113cm x 64cm)	5" x 17.38" x 7.50" (13cm x 44cm x 19cm)
N8759-DESP	58.50" x 25" (149cm x 64cm)	5" x 22.88" x 7.50" (13cm x 58cm x 19cm)
N8773-DESP	72.37" x 25" (184cm x 64cm)	5" x 28.38" x 7.50" (13cm x 72cm x 19cm)
N8787-DESP	86.25" x 25" (219cm x 64cm)	5" x 33.88" x 7.50" (13cm x 86cm x 19cm)
N8700-D-ESP-E Export Series		
N8717-D-ESP-E	16.87" X 25" (43cm x 64cm)	5" x 6.88" x 7.50" (13cm x 17cm x 19cm)
N8731-D-ESP-E	30.75" x 25" (78cm x 64cm)	5" x 11.88" x 7.50" (13cm x 30cm x 19cm)
N8745-D-ESP-E	44.62" x 25" (113cm x 64cm)	5" x 17.38" x 7.50" (13cm x 44cm x 19cm)
N8759-D-ESP-E	58.50" x 25" (149cm x 64cm)	5" x 22.88" x 7.50" (13cm x 58cm x 19cm)
N8773-D-ESP-E	72.37" x 25" (184cm x 64cm)	5" x 28.38" x 7.50" (13cm x 72cm x 19cm)
N8787-D-ESP-E	86.25" x 25" (219cm x 64cm)	5" x 33.88" x 7.50" (13cm x 86cm x 19cm)
N8700N Series		
N8746ND	44.62" x 15.0" (113cm x 38cm)	10.31" x 4.62" x 7" (26cm x 12cm x 18cm)
N8768N	66.50" x 15.0" (169cm x 38cm)	14.50" x 4.62" x 7" (37cm x 12cm x 18cm)
N8768ND	66.50" x 15.0" (169cm x 38cm)	14.50" x 4.62" x 7" (37cm x 12cm x 18cm)
N8700-R Series		
N8744-R	See drawing on page 17	10.31" x 4.62" x 7" (26cm x 12cm x 18cm)
N8759-R	See drawing on page 17	14.5" x 4.62" x 7" (37cm x 12cm x 18cm)
N8776-R	See drawing on page 17	18.69" x 4.62" x 7" (47cm x 12cm x 18cm)
N8794-R	See drawing on page 17	22.88" x 4.62" x 7" (58cm x 12cm x 18cm)
N8800 Series		
N8831	30.75" X 25" (78cm x 64cm)	12.25" x 4.25" x 7" (31cm x 11cm x 18cm)
N8845	44.63" x 25" (113cm x 64cm)	12.25" x 4.25" x 7" (31cm x 11cm x 18cm)
N8859	58.5" x 25" (149cm x 64cm)	12.25" x 4.25" x 7" (31cm x 11cm x 18cm)
N8873	72.38" x 25" (184cm x 64cm)	12.25" x 4.25" x 7" (31cm x 11cm x 18cm)
N8887	86.25" x 25" (219cm x 64cm)	12.25" x 4.25" x 7" (31cm x 11cm x 18cm)

Model	Counter Cutout Dimensions	Control Panel Cutout Dimensions
N8800-E Export Series		
N8831-E	30.75" X 25" (78cm x 64cm)	12.25" x 4.25" x 7" (31cm x 11cm x 18cm)
N8845-E	44.63" x 25" (113cm x 64cm)	12.25" x 4.25" x 7" (31cm x 11cm x 18cm)
N8859-E	58.5" x 25" (149cm x 64cm)	12.25" x 4.25" x 7" (31cm x 11cm x 18cm)
N8873-E	72.38" x 25" (184cm x 64cm)	12.25" x 4.25" x 7" (31cm x 11cm x 18cm)
N8887-E	86.25" x 25" (219cm x 64cm)	12.25" x 4.25" x 7" (31cm x 11cm x 18cm)

† Drop-In FlexiWell & FlexiTop Models N8600-FWP and N8200-FTP are within the FlexiWell manual 9291544

CURVED DROP-IN CUTOUT DETAILS

2 pan standard curved drop-in cutout detail for models:

- N8044-R
- N8144-BRP
- N8744-R

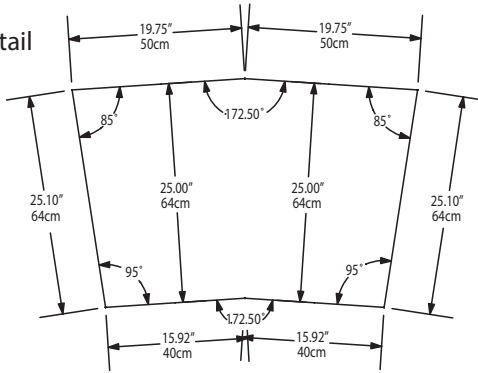

3 pan standard curved drop-in cutout detail for models:

- N8059-R
- N8159-BRP
- N8759-R

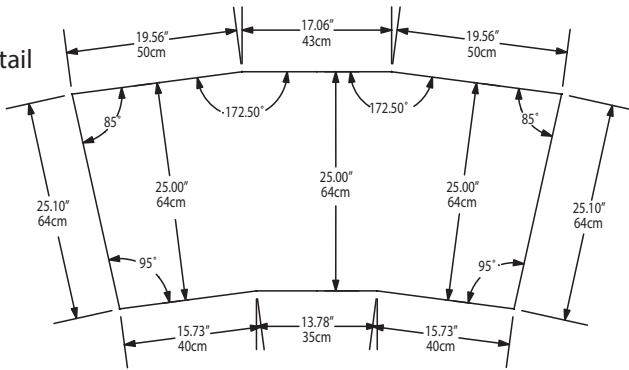

4 pan standard curved drop-in cutout detail for models:

- N8076-R
- N8176-BRP
- N8776-R

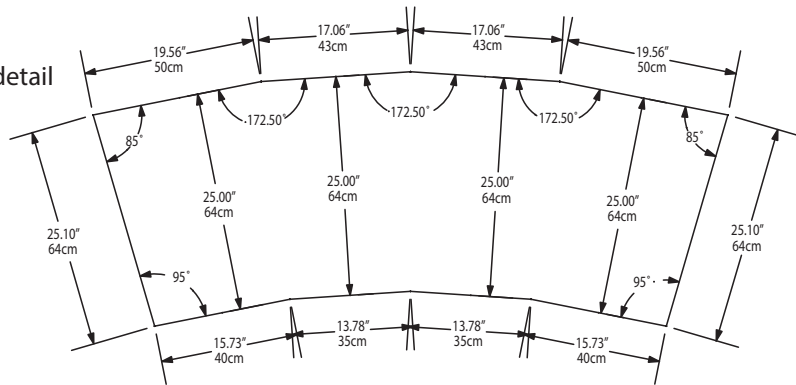

5 pan standard curved drop-in cutout detail or models:

- N8094-R
- N8194-BRP
- N8794-R

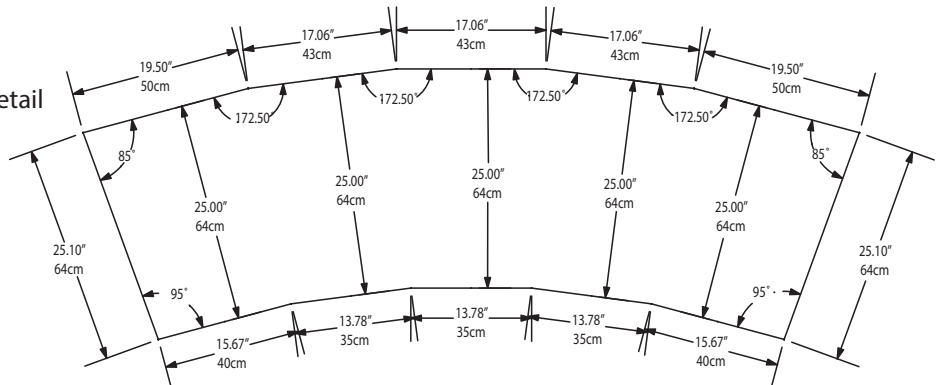

Drop-In Counter Installation

ICE COOLED DROP-IN UNITS

N8000, N8000N, N8000-R

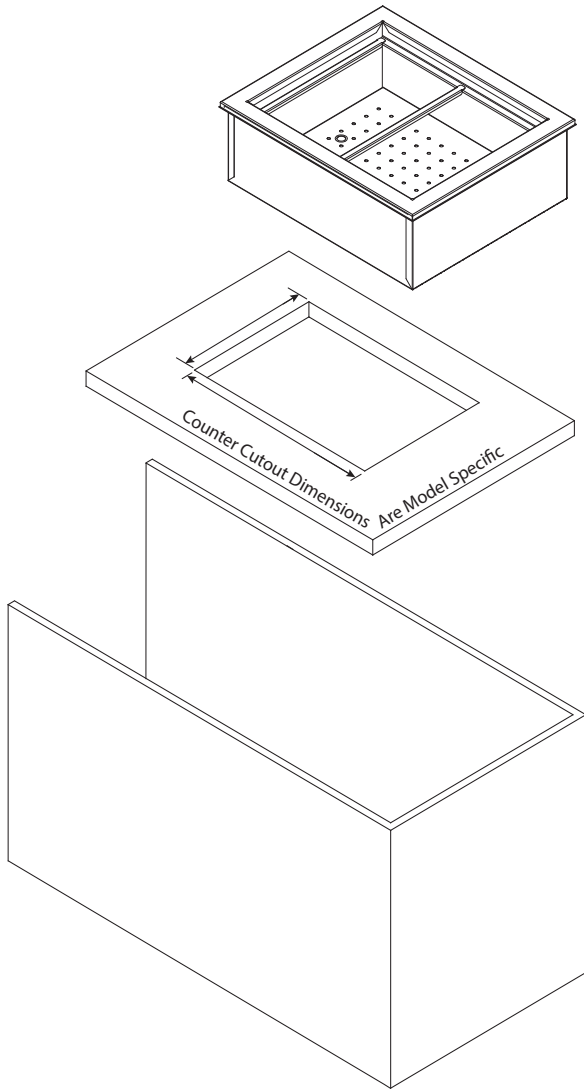

1. Place the ice cooled drop-in unit through the counter cutout.
2. A gasket is installed in the flange of each unit. The weight of the unit on the gasket forms a seal preventing liquids from seeping into the cut-out opening.
3. The 1" diameter drain on N8000, N8000N, N8000-R models is shipped loose and must be connected during installation.
 - A. Provided 1" (25mm) drain, nut and washer must be field installed to an appropriate container or floor drain following local code requirements. Sinks come standard with 1-1/2" basket strainer assemblies.



- B. Remove/drill foam out of drain hole.



- C. Apply thin ring of plumbers putty around the drain.
 - D. From the inside drop the drain into the drain hole.



- E. From the outside secure the drain with the washer and nut.



- F. Tighten the nut with channel locks, use a fork to hold the drain in place if necessary.
 - G. Clean up excess plumbers putty.

SELF-CONTAINED REFRIGERATED DROP-IN UNITS

8100-EFNP, N8100BP

For any non-standard installation consult the factory.

1. Install a GFCI receptacle a minimum of 14" (36cm) up from the cabinet bottom inside the partitions. We recommend installing a remote located power switch for ease of use.
2. Cabinet interior minimum dimensions:

Dimension	8148-EFNP	N8168-EFNP	8191-EFNP
A	46.87"/199cm	68.5"/174cm	90"/229cm
B	19"/48cm	19"/48cm	19"/48cm
C	26"/66cm	26"/66cm	26"/66cm
D	46.87"/199cm	68.5"/174cm	90"/229cm
E	17.25"/44cm	17.25"/44cm	17.25"/44cm
F	Min. 2.75"/7cm - Max. 4.75"/12cm		

Dimension	N8118BP	N8130BP	N8143BP
A	22.38"/57cm	29.75"/76cm	42.5"/108cm
B	27.75"/70cm	27.75"/70cm	27.75"/70cm
C	26"/66cm	26"/66cm	26"/66cm
D	17"/43cm	29.75"/76cm	42.5"/108cm
E	25"/64cm	25"/64cm	25"/64cm
F	Min. 2.75"/7cm - Max. 4.75"/12cm		

Dimension	N8156BP	N8169BP	N8181BP
A	55.25"/140cm	68"/173cm	80.75"/205cm
B	27.75"/70cm	27.75"/70cm	27.75"/70cm
C	26"/66cm	26"/66cm	26"/66cm
D	55.25"/140cm	68"/173cm	80.75"/205cm
E	25"/64cm	25"/64cm	25"/64cm
F	Min. 2.75"/7cm - Max. 4.75"/12cm		

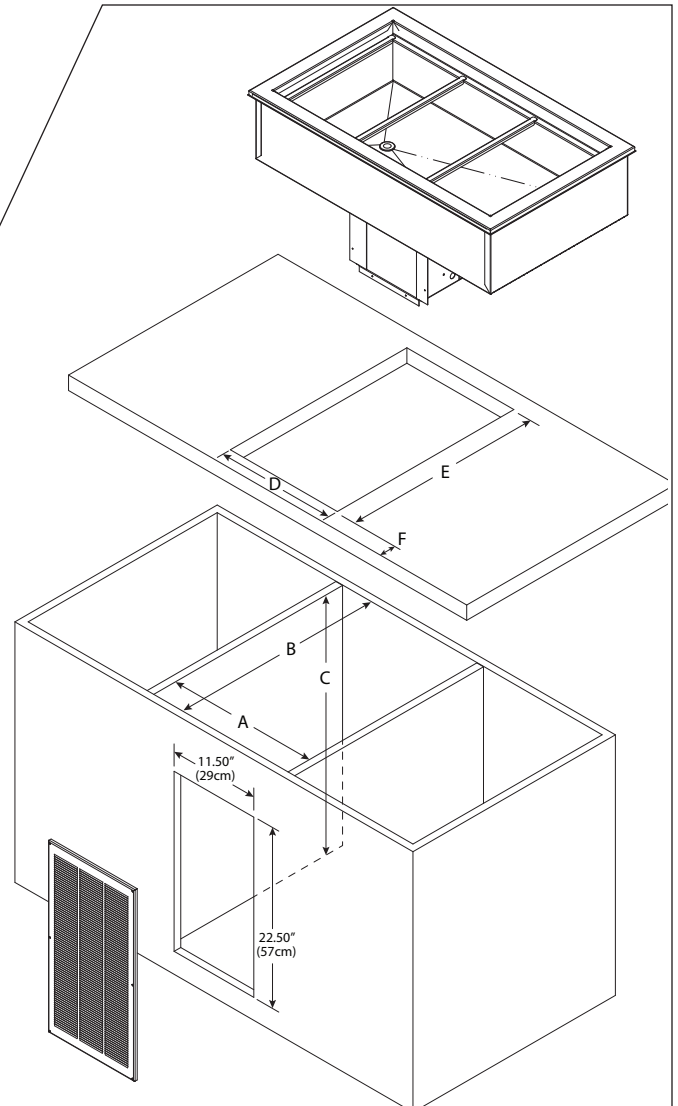

3. Place the condensing unit through the counter cutout.
4. Extend the telescoping duct from the front of the condensing unit to the back of the louver. This will prevent recirculation of discharge air. Export models do not have a telescoping duct, skip to step 6.

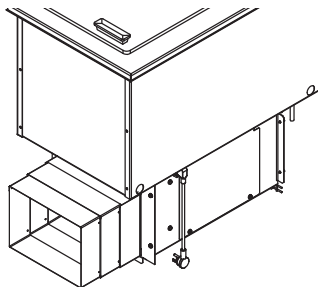

5. Put eight provided screws through the telescoping duct side walls to hold it at the desired depth.

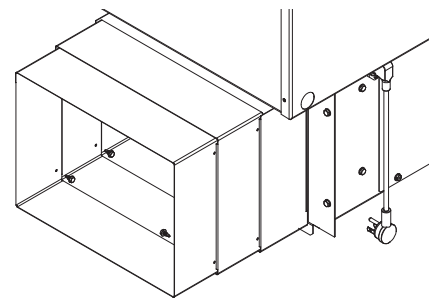

**Use Screws to Secure Desired Depth
3 of 8 Screws Shown**

6. Partitions must fully extend front to back and top to bottom.
7. Louver cutout must extend to bottom of cabinet and align with condenser face.

NOTE: The louver provided must be installed in front of



the condensing unit's finned coil. Any restriction to the proper air flow will void the compressor warranty.

- Louver measures 13.00" x 25.00" (33cm x 64cm).
- Louver Cutout Size is 11.50" x 22.50" (29cm x 57cm) (typical installation).

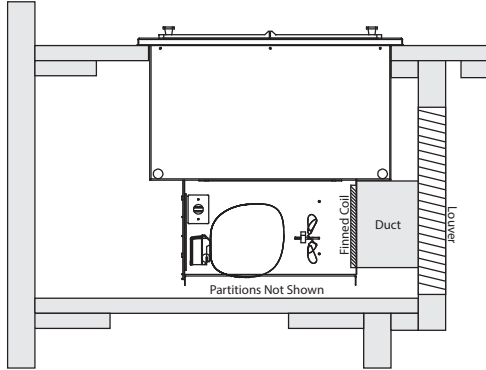

Typical Counter Cabinet

8. The 1" diameter drain on N8100BP, N8100-EFNP and N8100P models is shipped loose and must be connected during installation.
 - Provided 1" (25mm) drain, nut and washer must be field installed to an appropriate container or floor drain following local code requirements. Sinks come standard with 1-1/2" basket strainer assemblies.



- Remove/drill foam out of drain hole.



- Apply thin ring of plumbers putty around the drain.
- From the inside drop the drain into the drain hole.



- From the outside secure the drain with the washer and nut.

- Tighten the nut with channel locks, use a fork to hold the drain in place if necessary.
- Clean up excess plumbers putty.

Suggested Drainage Trap

Units may increase in performance if they have a drainage trap or shut-off valve installed. Installing the trap will stop warm air being introduced into the dry well of the unit.

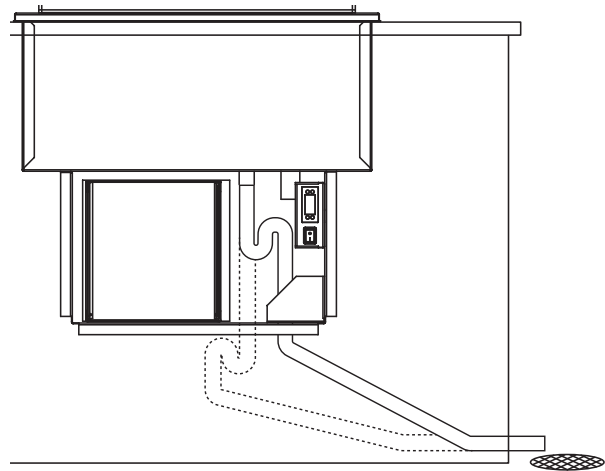

Rotating Condensing Unit

If the condensing unit is to be rotated 90 degrees you will need to supply an air flow divider which would be based on size of cabinet.

- Divider must partition cabinet on left and right side of louver to eliminate air recirculation.
- Divider to run the full height and width of the cabinet with cutout in the middle to accept drop-in.
- Divider can be made with any available material

8118-EFP Air Divider Build
Customer is responsible

N8118BP Air Divider Build
Customer is responsible

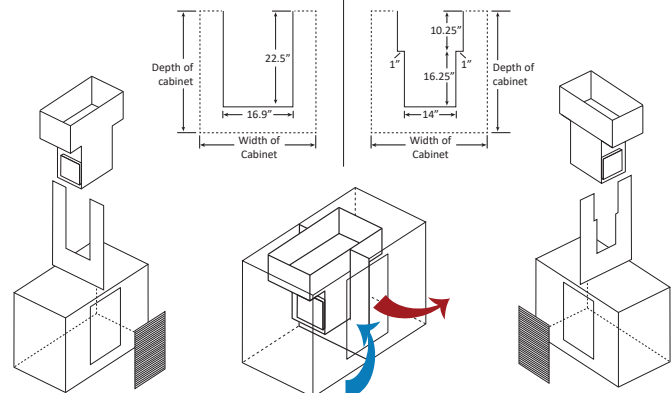

Dotted line is the interior dimension of cabinet. These dimensions are unknown and evaluated case by case upon installation.



SELF-CONTAINED REFRIGERATED DROP-IN UNITS
8100BRP, N8100-EFP

For any non-standard installation consult the factory.

1. Install a GFCI receptacle a minimum of 14" (36cm) up from the cabinet bottom inside the partitions. We recommend installing a remote located power switch for ease of use.
2. Cabinet interior minimum dimensions:

Dimension	N8146BRP	N8168BRP
A	45.75"/116cm	66.5"/169cm
B	19"/48cm	19"/48cm
C	26"/66cm	26"/66cm
D	45.75"/116cm	66.5"/169cm
E	17"/43cm	17"/43cm
F	Min. 2.75"/7cm - Max. 4.75"/12cm	

Dimension	N8118-EFP	N8132-EFP	N8145-EFP
A	22.38"/57cm	30.75"/78cm	44.25"/112cm
B	27.75"/70cm	27.75"/70cm	27.75"/70cm
C	26"/66cm	26"/66cm	26"/66cm
D	17"/43cm	30.75"/78cm	44.25"/112cm
E	25"/64cm	25"/64cm	25"/64cm
F	Min. 2.75"/7cm - Max. 4.75"/12cm		

Dimension	N8159-EFP	N8172-EFP	N8186_EFP
A	57.87"/147cm	71.5"/182cm	85"/216cm
B	27.75"/70cm	27.75"/70cm	27.75"/70cm
C	26"/66cm	26"/66cm	26"/66cm
D	57.87"/147cm	71.5"/182cm	85"/216cm
E	25"/64cm	25"/64cm	25"/64cm
F	Min. 2.75"/7cm - Max. 4.75"/12cm		

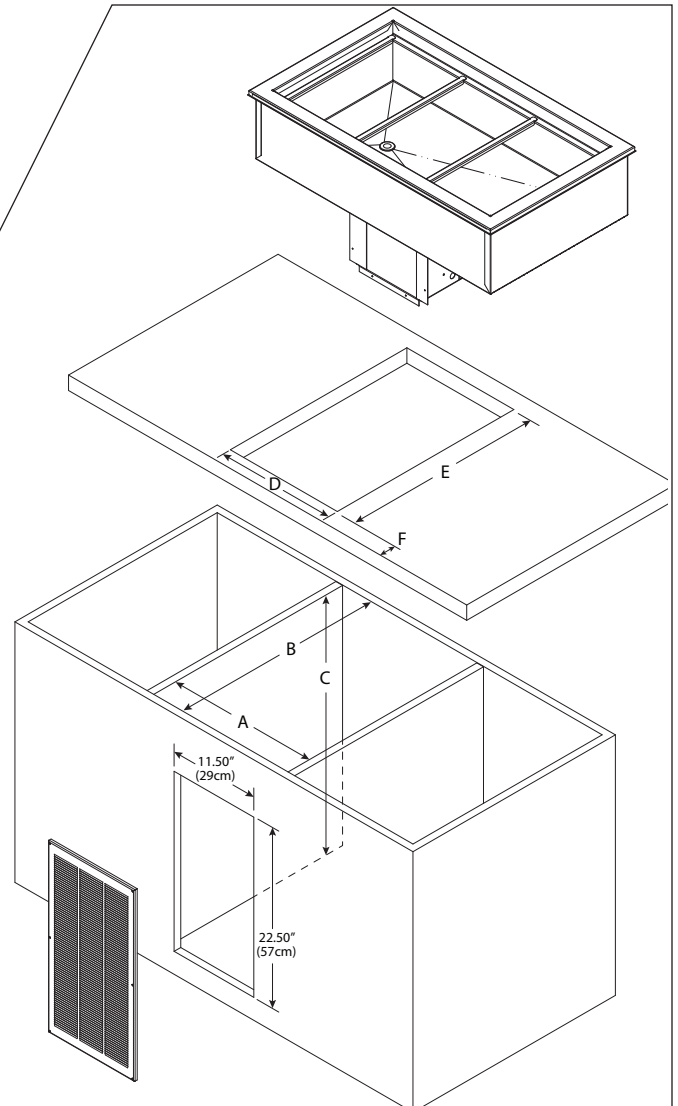

3. Place the condensing unit through the counter cutout.
4. Extend the telescoping duct from the front of the condensing unit to the back of the louver. This will prevent recirculation of discharge air. Export models do not have a telescoping duct, skip to step 6.

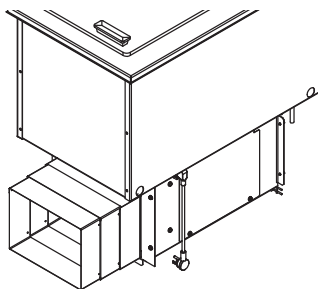

5. Put eight provided screws through the telescoping duct side walls to hold it at the desired depth.

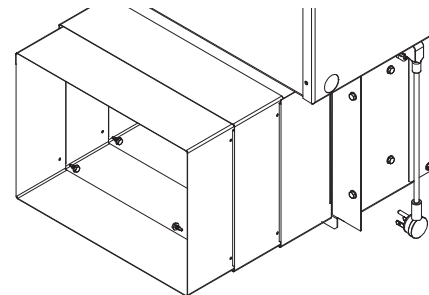

**Use Screws to Secure Desired Depth
 3 of 8 Screws Shown**

6. Partitions must fully extend front to back and top to bottom.
7. Louver cutout must extend to bottom of cabinet and align with condenser face.

NOTE: The louver provided must be installed in front of



the condensing unit's finned coil. Any restriction to the proper air flow will void the compressor warranty.

- Louver measures 13.00" x 25.00" (33cm x 64cm).
- Louver Cutout Size is 11.50" x 22.50" (29cm x 57cm) (typical installation).

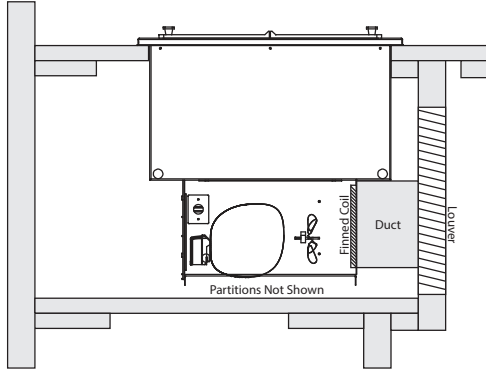

Typical Counter Cabinet

8. The 1" diameter drain on N8100-BRP and N8100EFP models is shipped loose and must be connected during installation.
 - A. Provided 1" (25mm) drain, nut and washer must be field installed to an appropriate container or floor drain following local code requirements. Sinks come standard with 1-1/2" basket strainer assemblies.



- B. Remove/drill foam out of drain hole.



- C. Apply thin ring of plumbers putty around the drain.
 - D. From the inside drop the drain into the drain hole.



- E. From the outside secure the drain with the washer and nut.



- F. Tighten the nut with channel locks, use a fork to hold the drain in place if necessary.
 - G. Clean up excess plumbers putty.

Suggested Drainage Trap

Units may increase in performance if they have a drainage trap or shut-off valve installed. Installing the trap will stop warm air being introduced into the dry well of the unit.

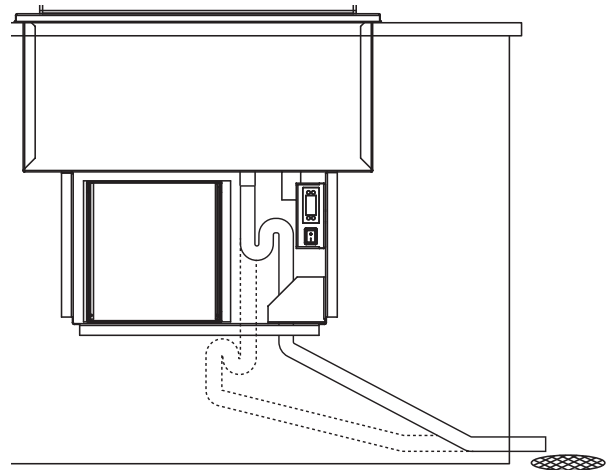

SELF-CONTAINED REFRIGERATED DROP-IN UNITS

8100-FAP

For any non-standard installation consult the factory.

1. Install a GFCI receptacle a minimum of 14" (36cm) up from the cabinet bottom inside the partitions. We recommend installing a remote located power switch for ease of use.
2. Cabinet interior minimum dimensions:

Dimension	N8131-FAP	N8144-FAP
A	30.25"/77cm	43"/109cm
B	27.75"/70cm	27.75"/70cm
C	26"/66cm	26"/66cm
D	30.25"/77cm	43"/109cm
E	25.5"/65cm	25.5"/65cm
F	Min. 2.75"/7cm - Max. 4.75"/12cm	
G	12"	
H	23.50"	

Dimension	N8157-FAP	N8169-FAP	N8182-FAP
A	55.75"/142cm	68.5"/174cm	81.25"/206cm
B	27.75"/70cm	27.75"/70cm	27.75"/70cm
C	26"/66cm	26"/66cm	26"/66cm
D	55.75"/142cm	68.5"/174cm	81.25"/206cm
E	25.5"/65cm	25.5"/65cm	25.5"/65cm
F	Min. 2.75"/7cm - Max. 4.75"/12cm		
G	15.75"		
H	23.50"		

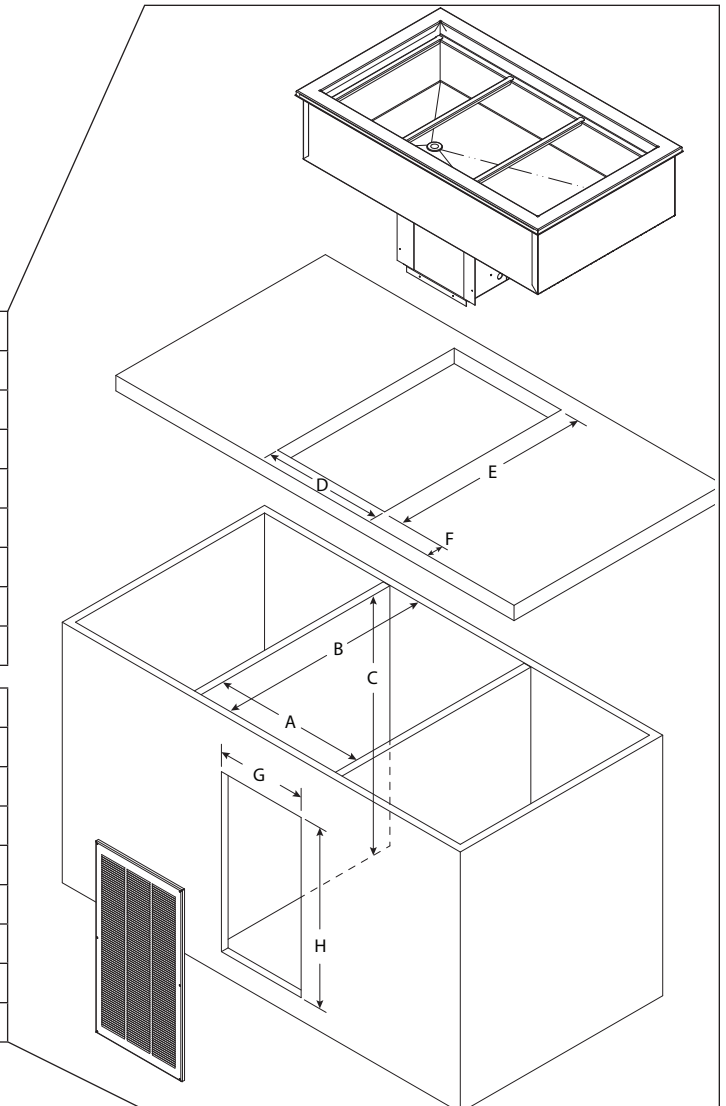

3. Place the condensing unit through the counter cutout.
4. Extend the telescoping duct from the front of the condensing unit to the back of the louver. This will prevent recirculation of discharge air. Export models do not have a telescoping duct, skip to step 6.

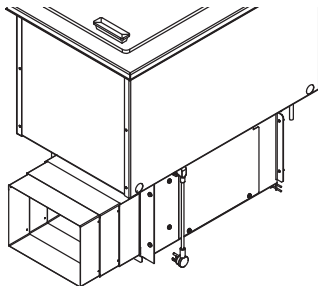

5. Put eight provided screws through the telescoping duct side walls to hold it at the desired depth.

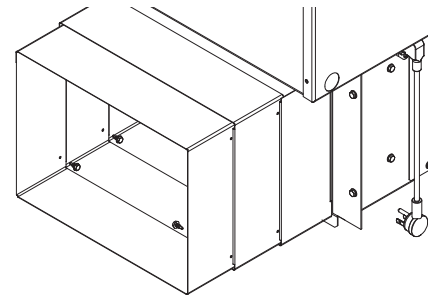

**Use Screws to Secure Desired Depth
3 of 8 Screws Shown**

6. Partitions must fully extend front to back and top to bottom.
7. Louver cutout must extend to bottom of cabinet and align with condenser face.

NOTE: The louver provided must be installed in front of



the 1" diameter drain on N8100-FAP models is shipped loose and must be connected during installation. N8157-FAP, N8169-FAP and N8182-FAP have two 1" drains.

- A. Provided 1" (25mm) drain, nut and washer must be field installed to an appropriate container or floor drain following local code requirements. Sinks come standard with 1-1/2" basket strainer assemblies.



- B. Remove/drill foam out of drain hole.



- C. Apply thin ring of plumbers putty around the drain.
- D. From the inside drop the drain into the drain hole.



- E. From the outside secure the drain with the washer and nut.

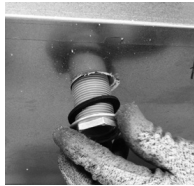

- F. Tighten the nut with channel locks, use a fork to hold the drain in place if necessary.
- G. Clean up excess plumbers putty.

- 8. Inside the well, the fan assembly has standoff brackets with tabs. The tabs should be bent up.
- 9. Place the coil assembly cover slots over the bracket tabs. This will secure the cover is in the correct location and will not disrupt the air flow.
- 10. The upright air diffuser will only fit one way on the drain side.

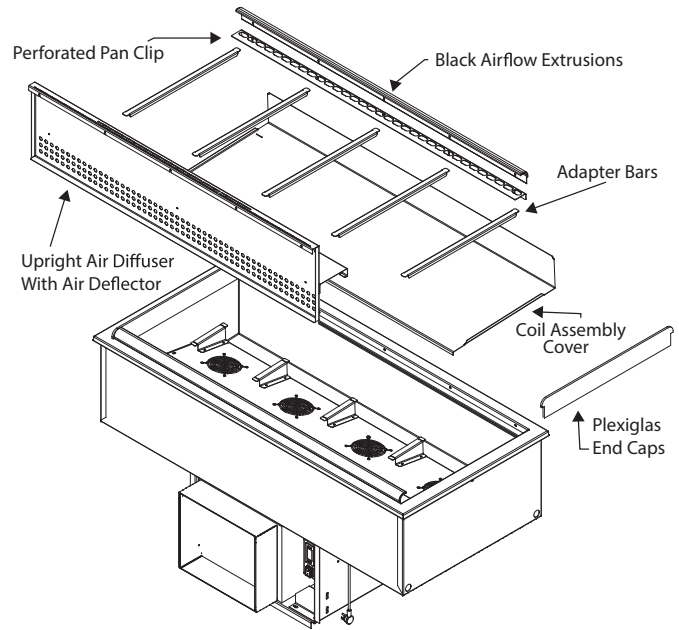

NOTE

FAP Drainage Trap

An FAP unit should have a drainage trap installed to ensure proper operation. Failure to install the trap will result in warm air being introduced into the well of the unit. If not installed immediately under the unit, the trap should be installed just below the compressor frame.

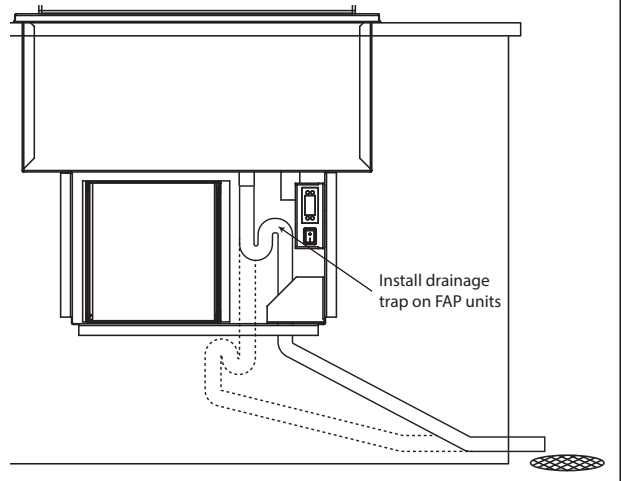

SELF-CONTAINED REFRIGERATED DROP-IN UNITS
N8200P, N8200-GP, N8200-STP

For any non-standard installation consult the factory.

1. Install a GFCI receptacle a minimum of 14" (36cm) up from the cabinet bottom inside the partitions. We recommend installing a remote located power switch for ease of use
2. Cabinet interior minimum dimensions:

Dimension	N8231P/GP	N8245P/GP	N8259P/GP
A	30.75"/78cm	44.25"/112cm	58.5"/149cm
B	27.75"/70cm	27.75"/70cm	27.75"/70cm
C	26"/66cm	26"/66cm	26"/66cm
D	30.75"/78cm	44.25"/112cm	58.5"/149cm
E	25"/64cm	25"/64cm	25"/64cm
F	Min. 2.75"/7cm - Max. 4.75"/12cm		

Dimension	N8273P/GP	N8287P/GP	
A	72.38"/184cm	86.25"/219cm	
B	27.75"/70cm	27.75"/70cm	
C	26"/66cm	26"/66cm	
D	72.38"/184cm	86.25"/219cm	
E	25"/64cm	25"/64cm	
F	Min. 2.75"/7cm - Max. 4.75"/12cm		

Dimension	N8230-STP	N8240-STP	N8256-STP
A	28.6"/73cm	38.65"/98cm	54.6"/139cm
B	27.75"/70cm	27.75"/70cm	27.75"/70cm
C	26"/66cm	26"/66cm	26"/66cm
D	28.6"/73cm	38.65"/98cm	54.6"/139cm
E	21.12"/54cm	28.75"/73cm	21.12"/54cm
F	Min. 2.75"/7cm - Max. 4.75"/12cm		

Dimension	N8258-STP	N8275-STP	
A	56.6"/144cm	74.5"/189cm	
B	27.75"/70cm	27.75"/70cm	
C	26"/66cm	26"/66cm	
D	56.6"/144cm	74.5"/189cm	
E	28.75"/73cm	28.75"/73cm	
F	Min. 2.75"/7cm - Max. 4.75"/12cm		

3. Place the condensing unit through the counter cutout.
4. Extend the telescoping duct from the front of the condensing unit to the back of the louver. This will prevent recirculation of discharge air. Export models do not have a telescoping duct, skip to step 6.

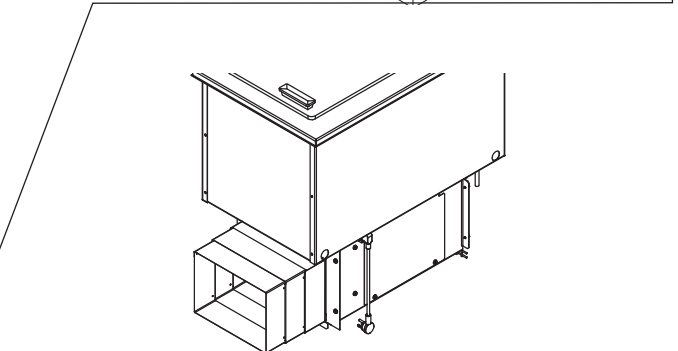
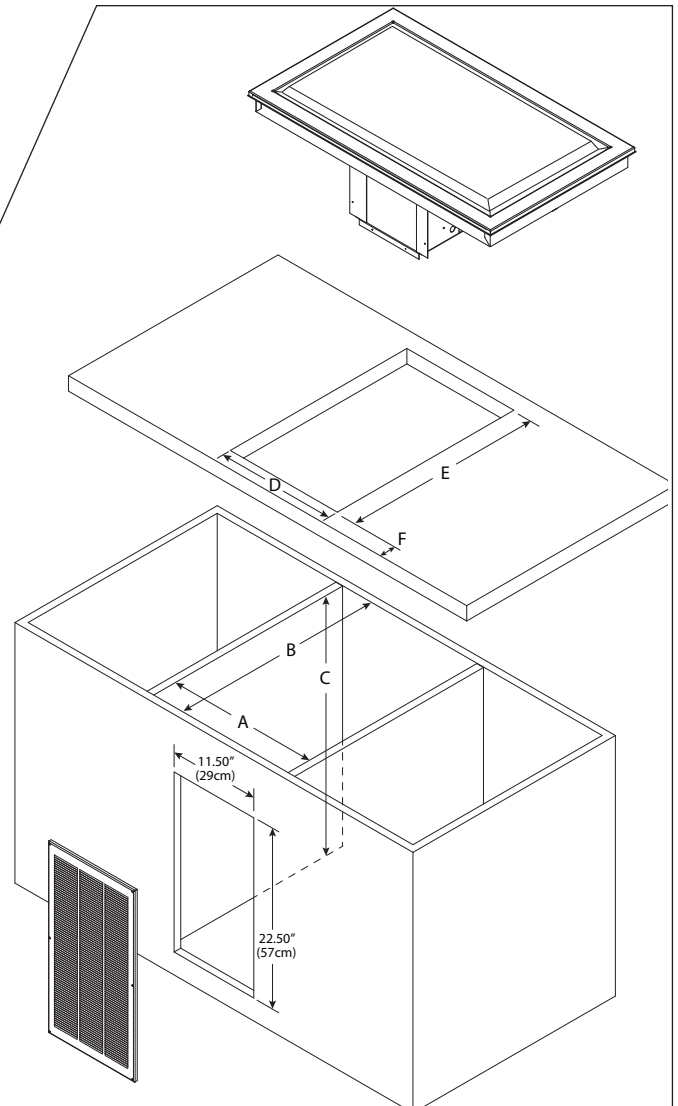

5. Put eight provided screws through the telescoping duct side walls to hold it at the desired depth.



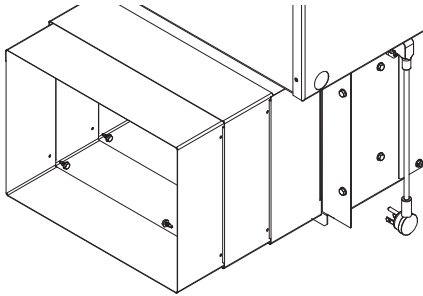

**Use Screws to Secure Desired Depth
3 of 8 Screws Shown**

6. Partitions must fully extend front to back and top to bottom.
7. Louver cutout must extend to bottom of cabinet and align with condenser face.

NOTE: The louver provided must be installed in front of the condensing unit's finned coil. Any restriction to the proper air flow will void the compressor warranty.

- Louver measures 13.00" x 25.00" (33cm x 64cm).
- Louver Cutout Size is 11.50" x 22.50" (29cm x 57cm) (typical installation).

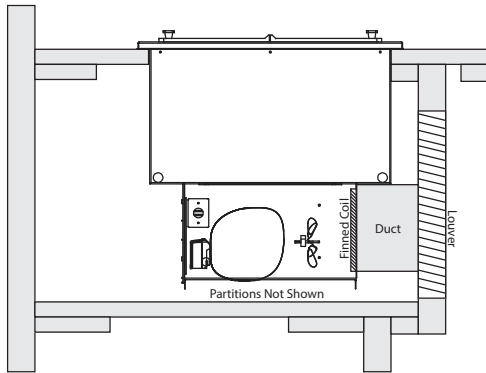

Drainage

N8200P and N8200-STP have a 1/2" drain.

N8200-GP have a 3/4" drain located on end/center.

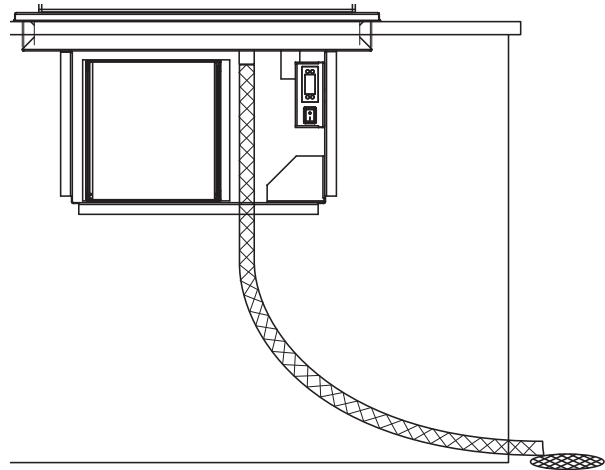

† Drop-In FlexiWell & FlexiTop Models N8600-FWP and N8200-FTP are within the FlexiWell manual 9291544



**SELF-CONTAINED COMBO HOT/COLD DROP-IN UNITS
N8600P**

For any non-standard installation consult the factory.

1. Cabinet interior minimum dimensions:

Dimension	N8630P	N8643P	N8656P
A	29.75"/76cm	42.5"/108cm	55.25"/140cm
B	29"/74cm	29"/74cm	29"/74cm
C	28"/71cm	28"/71cm	28"/71cm
D	29.75"/76cm	42.5"/108cm	55.5"/140cm
E	25"/64cm	25"/64cm	25"/64cm
F	4.75"/12cm	Min. 2.75"/7cm - Max. 4.75"/12cm	

Dimension	N8669P	N8681P	N86120P
A	68"/173cm	80.75"/205cm	101.75"/258cm
B	29"/74cm	29"/74cm	29"/74cm
C	28"/71cm	28"/71cm	28"/71cm
D	68"/173cm	80.75"/205cm	101.75"/258cm
E	25"/64cm	25"/64cm	25"/64cm
F	4.75"/12cm	Min. 2.75"/7cm - Max. 4.75"/12cm	

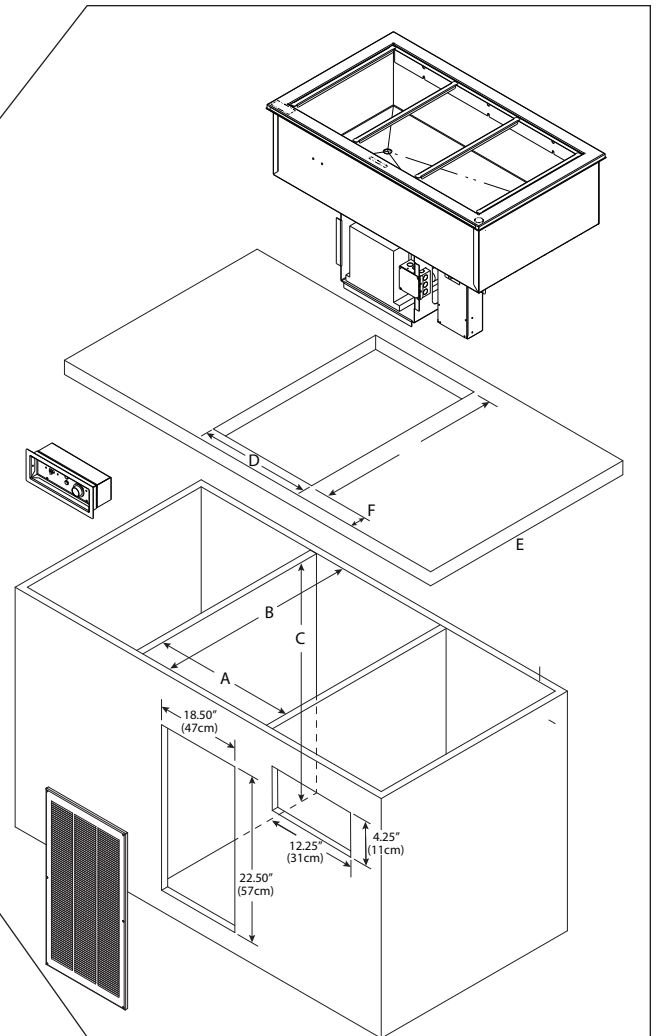

2. Place the condensing unit through the counter cutout.
3. Extend the telescoping duct from the front of the condensing unit to the back of the louver. This will prevent recirculation of discharge air. Export models do not have a telescoping duct, skip to step 6.

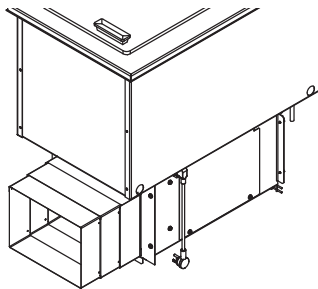

4. Put eight provided screws through the telescoping duct side walls to hold it at the desired depth.

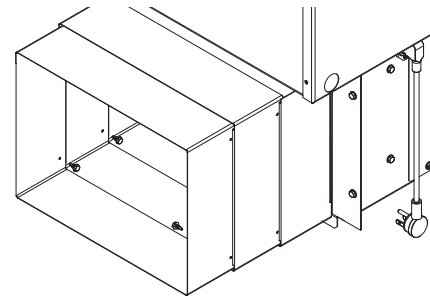

**Use Screws to Secure Desired Depth
3 of 8 Screws Shown**

5. Partitions must fully extend front to back and top to bottom.
6. Louver cutout must extend to bottom of cabinet and align with condenser face.

NOTE: The louver provided must be installed in front of



NOTE: CONT: the condensing unit's finned coil.
Any restriction to the proper air flow will void the compressor warranty.

- Louver measures 20.00" x 25.00" (51cm x 64cm).
- Louver Cutout Size is 18.50" x 22.50" (47cm x 57cm) (typical installation).

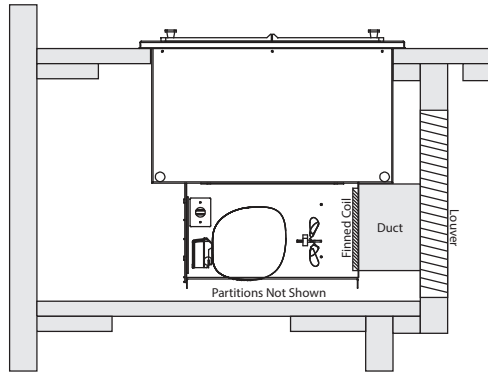

NOTE: For units equipped with an Auto Fill system the Auto Fill activation switch must be installed a minimum of 14" up from the cabinet bottom.

NOTE: For units equipped with an Auto Fill system the bottom of the unit must be a minimum of 4" up from the cabinet bottom.

Suggested Drainage Trap

Units may increase in performance if they have a drainage trap or shut-off valve installed. Installing the trap will stop warm air being introduced into the dry well of the unit.

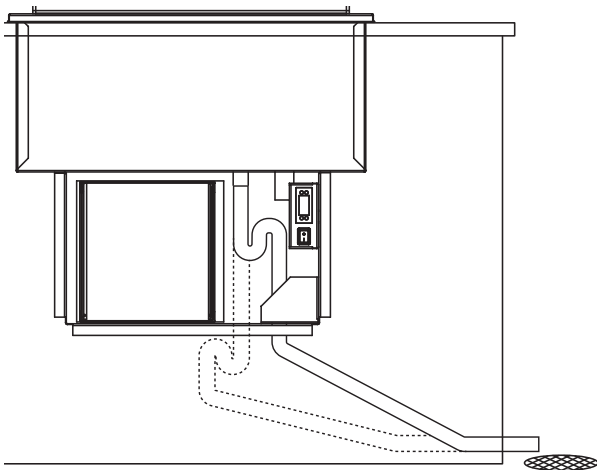

† Drop-In FlexiWell & FlexiTop Models N8600-FWP and N8200-FTP are within the FlexiWell manual 9291544

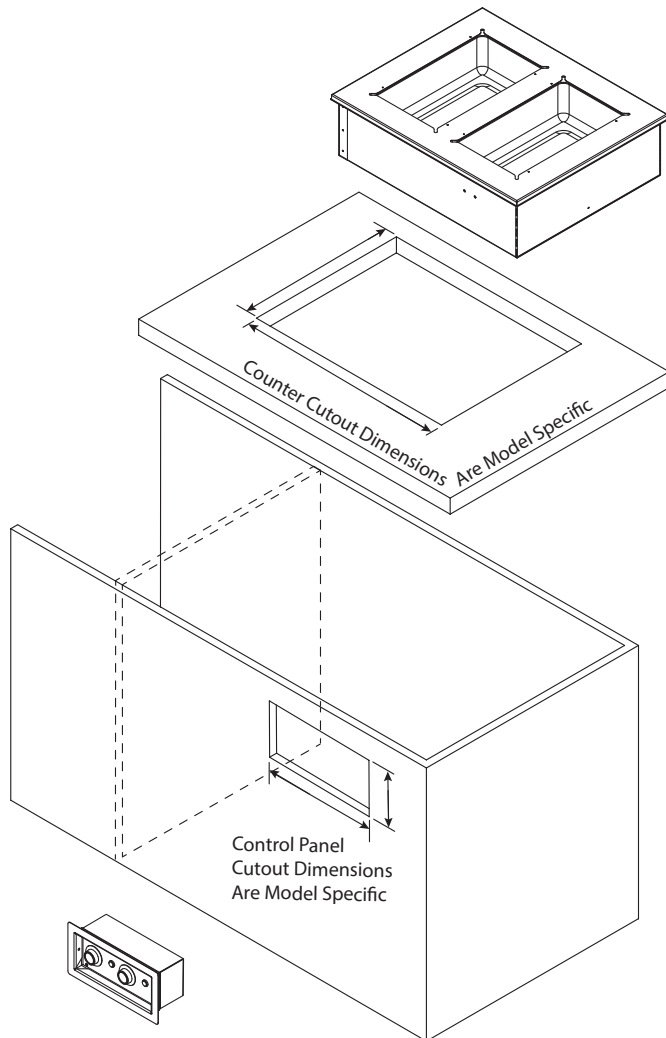
HOT FOOD WELL DROP-IN UNITS**N8700-D, N8700-DESP, N8700N, N8700-R, N8800**

1. Orient the control panel with the indicator light for each control to the right of the control.
 - N8700 series units have 48" (122cm) of conduit.
 - N8800 Series units have 34" (86cm) of conduit.
2. N8700 control panel is designed to be installed on the side opposite the drains.
 - Installed on the same side as the drains, the control panel will either be upside down or the knobs will control the opposite wells.



Infinite control shown, directions also apply to digital control

3. Place the control panel into the cutout from inside the cabinet. Place the collar into the cutout from outside the cabinet. Secure with two screws.
4. Place the hot food well drop-in unit through the counter cutout.
5. A gasket is installed in the flange of each unit. The weight of the unit on the gasket forms a seal preventing liquids from seeping into the cut-out opening.
6. Plumb to a floor drain.
 - All N8700 series are equipped with 1/2" (13mm) female NPT drains, one per well located right rear corner, manifold to 1/2" (13mm) gate valve.
 - N8800 wells are sloped to a 1" (25mm) male NPT stainless steel drain. Use a 1" female coupling.

Electrical Service

⚠ DANGER

Check all wiring connections, including factory terminals, before operation. Connections can become loose during shipment and installation.

⚠ Warning

This appliance must be grounded and all field wiring must conform to all applicable local and national codes. Refer to rating plate for proper voltage. It is the responsibility of the end user to provide the disconnect means to satisfy the authority having jurisdiction.

VOLTAGE

All electrical work, including wire routing and grounding, must conform to local, state and national electrical codes.

The following precautions must be observed:

- The equipment must be grounded.
- A separate fuse/circuit breaker must be provided for each unit.
- A qualified electrician must determine proper wire size dependent upon location, materials used and length of run (minimum circuit ampacity can be used to help select the wire size).
- The maximum allowable voltage variation is ±10% of the rated voltage at equipment start-up (when the electrical load is highest).
- Check all green ground screws, cables and wire connections to verify they are tight before start-up.

GROUND FAULT CIRCUIT INTERRUPTER

Ground Fault Circuit Interrupter (GFCI/GFI) protection is a system that shuts down the electric circuit (opens it) when it senses an unexpected loss of power, presumably to ground. Manitowoc does not recommend the use of GFCI/GFI circuit protection to energize our equipment. If code requires the use of a GFCI/GFI then you must follow the local code. The circuit must be dedicated, sized properly and there must be a panel GFCI/GFI breaker. We do not recommend the use of GFCI/GFI outlets to energize our equipment as they are known for more intermittent nuisance trips than panel breakers.

Note

These appliances will operate within the marked rated voltage range without adjustment.

RATED AMPERAGES, HORSEPOWER, VOLTAGE & POWER CORD CHART

Units with plugs are supplied with approximately 6ft (183cm) cords.

Model	V, Hz, Ph	Amps	H.P.	Plug
8100-EFP Series R290				
8118-EFP	115, 60, 1	2.4	1/5	NEMA 5-15P
8132-EFP	115, 60, 1	2.4	1/5	NEMA 5-15P
8145-EFP	115, 60, 1	3.7	1/4	NEMA 5-15P
8159-EFP	115, 60, 1	3.7	1/4	NEMA 5-15P
8172-EFP	115, 60, 1	4.8	1/3	NEMA 5-15P
8186-EFP	115, 60, 1	4.8	1/3	NEMA 5-15P
8100-EF-E Export Series				
8118-EF-E	230-240, 50, 1	2.5 Amps / 600 Watts	1/4	Varies Per Destination
8132-EF-E				
8145-EF-E				
8159-EF-E				
8172-EF-E				
8186-EF-E				
8100-EFNP Series R290				
8148-EFNP	115, 60, 1	2.4	1/5	NEMA 5-15P
8169-EFNP		3.7	1/4	
8191-EFNP		4.8	1/3	
8100-EFN-E Export Series				
8148-EFN-E	230-240, 50, 1	2.5 Amps / 600 Watts	1/4	Varies Per Destination
8169-EFN-E				
8191-EFN-E				
N8000 Series - NA				
N8000N Series - NA				
N8000-R Series - NA				
N8100BP Series - R290				
N8118BP	115, 60, 1	2.0	1/5	NEMA 5-15P
N8130BP	115, 60, 1	2.0	1/5	NEMA 5-15P
N8143BP	115, 60, 1	3.1	1/4	NEMA 5-15P
N8156BP	115, 60, 1	3.1	1/4	NEMA 5-15P
N8169BP	115, 60, 1	3.1	1/4	NEMA 5-15P
N8181BP	115, 60, 1	4.6	1/3	NEMA 5-15P
N8100B-E Export Series - R404A				
N8118B-E	230-240, 50, 1	1.5 Amps / 360 Watts	1/5	Varies Per Destination
N8130B-E				
N8143B-E				
N8100B-E Export Series - R134A				
N8156B-E	230-240, 50, 1	2.5 Amps / 600 Watts	1/4	Varies Per Destination
N8169B-E				
N8100BRP Series - R290				
N8144-BRP	115, 60, 1	2.4	1/5	NEMA 5-15P
N8159-BRP	115, 60, 1	3.7	1/4	NEMA 5-15P
N8176-BRP	115, 60, 1	3.7	1/4	NEMA 5-15P
N8194-BRP	115, 60, 1	3.7	1/4	NEMA 5-15P
N8100-FAP Series - R290				
N8131-FAP	115, 60, 1	4.7	1/4	NEMA 5-15P
N8144-FAP	115, 60, 1	4.7	1/4	NEMA 5-15P
N8157-FAP	115, 60, 1	9.3	1/2	NEMA 5-15P
N8169-FAP	115, 60, 1	9.3	1/2	NEMA 5-15P
N8182-FAP	115, 60, 1	9.3	1/2	NEMA 5-15P
N8100NB Series - R290				
N8146NBP	115, 60, 1	2	1/5	NEMA 5-15P
N8168NBP	115, 60, 1	3.1	1/4	NEMA 5-15P



Model	V, Hz, Ph	Amps	H.P.	Plug
N8100NB-E Export Series				
N8146NB-E N8168NB-E	230-240, 50, 1	1.5 Amps / 360 Watts	1/5	Varies Per Destination
N8200P Series				
N8231P	115, 60, 1	2.4	1/5	NEMA 5-15P
N8245P	115, 60, 1	2.4	1/5	NEMA 5-15P
N8259P	115, 60, 1	3.7	1/4	NEMA 5-15P
N8273P	115, 60, 1	3.7	1/4	NEMA 5-15P
N8287P	115, 60, 1	4.8	1/3	NEMA 5-15P
N8200-E Export Series				
N8231-E	230-240, 50, 1	1.5 Amps / 360 Watts	1/5	Varies Per Destination
N8245-E	230-240, 50, 1	1.5 Amps / 360 Watts	1/5	Varies Per Destination
N8259-E	230-240, 50, 1	2.5 Amps / 600 Watts	1/4	Varies Per Destination
N8273-E	230-240, 50, 1	2.5 Amps / 600 Watts	1/4	Varies Per Destination
N8287-E	230-240, 50, 1	2.8 Amps / 650 Watts	1/3	Varies Per Destination
N8200GP Series				
N8231GP	115, 60, 1	2.4	1/5	NEMA 5-15P
N8245GP	115, 60, 1	3.7	1/4	NEMA 5-15P
N8259GP	115, 60, 1	4.8	1/3	NEMA 5-15P
N8273GP	115, 60, 1	4.8	1/3	NEMA 5-15P
N8200G-E Export Series				
N8231G-E	230-240, 50, 1	1.5 Amps / 360 Watts	1/5	Varies Per Destination
N8245G-E	230-240, 50, 1	1.5 Amps / 360 Watts	1/5	Varies Per Destination
N8259G-E	230-240, 50, 1	2.8 Amps / 672 Watts	1/3	Varies Per Destination
N8200-STP Series				
N8230-STP	115, 60, 1	2.4	1/5	NEMA 5-15P
N8240-STP		2.4	1/5	
N8256-STP		3.7	1/4	
N8258-STP		3.7	1/4	
N8275-STP		4.8	1/3	
N8600P Series				
N8630P	120, 60, 1	24.0	1/4	Hard Wire
N8643P	120/240, 60, 1	21.0	1/4	Hard Wire
N8656P	120/240, 60, 1	21.0	1/4	Hard Wire
N8669P	120/240, 60, 1	43.0	1/4	Hard Wire
N8681P	120/240, 60, 1	43.0	1/3	Hard Wire
N8700D Series				
N8717-D	120, 60, 1	8.3	NA	Hard Wire
N8731-D	120, 60, 1	16.6	NA	Hard Wire
N8745-D	208-230, 60, 1	15.0/16.0	NA	Hard Wire
N8759-D	208-230, 60, 1	20.0/22.0	NA	Hard Wire
N8773-D	208-230, 60, 1	24.0/27.0	NA	Hard Wire
N8787-D	208-230, 60, 1	29.0/32.0	NA	Hard Wire

Model	V, Hz, Ph	Amps	H.P.	Plug
N8700D-E Export Series				
N8717-D-E	240, 50, 1	6.0 Amps / 1450 Watts	NA	Hard Wire
N8731-D-E	240, 50, 1	12.1 Amps / 2900 Watts	NA	Hard Wire
N8745-D-E	240, 50, 1	18.1 Amps/ 4350 Watts	NA	Hard Wire
N8759-D-E	240, 50, 1	24.2 Amps / 5800 Watts	NA	Hard Wire
N8773-D-E	240, 50, 1	30.2 Amps / 7250 Watts	NA	Hard Wire
N8787-D-E	240, 50, 1	36.3 Amps / 8700 Watts	NA	Hard Wire
N8700DESP Series				
N8717-DESP	208-230, 60, 1	2.4/2.7	NA	Hard Wire
N8731-DESP	208-230, 60, 1	4.8/5.4	NA	Hard Wire
N8745-DESP	208-230, 60, 1	7.2/8.1	NA	Hard Wire
N8759-DESP	208-230, 60, 1	9.6/10.8	NA	Hard Wire
N8773-DESP	208-230, 60, 1	12.0/13.5	NA	Hard Wire
N8787-DESP	208-230, 60, 1	14.4/16.2	NA	Hard Wire
N8700-D-ESP-E Export Series				
N8717-D-ESP-E	240, 50, 1	2.1 Amps / 500 Watts	NA	Hard Wire
N8731-D-ESP-E	240, 50, 1	4.2 Amps / 1000 Watts	NA	Hard Wire
N8745-D-ESP-E	240, 50, 1	6.3 Amps / 1500 Watts	NA	Hard Wire
N8759-D-ESP-E	240, 50, 1	8.4 Amps / 2000 Watts	NA	Hard Wire
N8773-D-ESP-E	240, 50, 1	10.5 Amps / 2500 Watts	NA	Hard Wire
N8787-D-ESP-E	240, 50, 1	12.6 Amps / 3000 Watts	NA	Hard Wire
N8700N Series				
N8746ND	120, 60, 1	17.0	NA	Hard Wire
N8768N	208-230, 60, 1	15.0/16.0	NA	Hard Wire
N8768ND	208-230, 60, 1	15.0/16.0	NA	Hard Wire
N8700-R Series				
N8744-R	120, 60, 1	16.6	NA	Hard Wire
N8759-R	208-230, 60, 1	15.0/16.0	NA	Hard Wire
N8776-R	208-230, 60, 1	20.0/22.0	NA	Hard Wire
N8794-R	208-230, 60, 1	24.0/27.0	NA	Hard Wire
N8800 Series				
N8831	120, 60, 1	17.0	NA	Hard Wire
N8845	208-230, 60, 1	15.0/16.0	NA	Hard Wire
N8859	208-230, 60, 1	20.0/22.0	NA	Hard Wire
N8873	208-230, 60, 1	24.0/27.0	NA	Hard Wire
N8887	208-230, 60, 1	29.0/32.0	NA	Hard Wire
N8800-E Export Series				
N8831-E	240, 50, 1	12.1 Amps / 2900 Watts	NA	Hard Wire
N8845-E	240, 50, 1	18.1 Amps/ 4350 Watts	NA	Hard Wire
N8859-E	240, 50, 1	24.2 Amps / 5800 Watts	NA	Hard Wire
N8873-E	240, 50, 1	30.2 Amps / 7250 Watts	NA	Hard Wire
N8887-E	240, 50, 1	36.3 Amps / 8700 Watts	NA	Hard Wire



Refrigeration

Temperature Class for all Export units is N.

Model	BTU Load	Evap BTU/TD/ TEMP	Sys Cap	Refrig. Charge
8100-EFP Series				
8118-EFP	218	12/55°/-20°	662	120g
8132-EFP	408	22/42°/-7°	902	120g
8145-EFP	598	31/43°/-8°	1323	120g
8159-EFP	788	41/37°/-2°	1483	120g
8172-EFP	979	50/39°/-4°	1939	150g
8186-EFP	1169	60/35°/0°	2084	150g
8100-EF-E Export Series				
8118-EF-E	204	19/50°/-15°	928	454g
8132-EF-E	379	26/42°/-7°	1112	454g
8145-EF-E	569	35/36°/-1°	1259	454g
8159-EF-E	758	43/32°/3°	1373	454g
8172-EF-E	948	51/29°/6°	1469	454g
8186-EF-E	1138	59/26°/9°	1529	454g
8100-EFNP Series				
8148-EFNP	408	21/42°/-7°	895	120g
8169-EFNP	535	28/45°/-10°	1263	120g
8191-EFNP	788	42/36°/1°	1505	120g
8100-EFN-E Export Series				
8148-EFN-E	379	26/42°/-7°	1112	454g
8169-EFN-E	569	35/36°/-1°	1259	454g
8191-EFN-E	758	43/32°/13°	1373	454g
N8000 Series NA				
N8000N Series - NA				
N8000-R Series - NA				
N8100BP Series				
N8118BP	181	11/55°/-17°	593	60g
N8130BP	346	15/47°/-9°	713	60g
N8143BP	512	19/52°/-14°	1014	60g
N8156BP	678	24/48°/-10°	1126	75g
N8169BP	844	25/44°/-6°	1220	75g
N8181BP	1010	32/51°/-13°	1627	90g
N8100B-E Export Series - R404A				
N8118B-E	204	19/38°/-3°	708	454g
N8130B-E	379	26/31°/4°	812	454g
N8143B-E	569	35/26°/9°	889	454g
N8100B-E Export Series - R134A				
N8156B-E	758	43/32°/3°	1373	454g
N8169B-E	948	51/29°/6°	1469	454g
N8100BRP Series				
N8144-BRP	455	15/52°/-14°	779	120g
N8159-BRP	670	19/55°/-17°	1066	120g
N8176-BRP	889	24/51°/-13°	1192	120g
N8194-BRP	1108	28/47°/-9°	1297	120g
N8100-FAP Series				
N8131-FAP	996	144/16°/18°	2354	150g
N8144-FAP	1137	144/16°/18°	2354	150g
N8157-FAP	2294	289/16°/18°	4749	150g
N8169-FAP	2412	289/16°/18°	4749	150g
N8182-FAP	2507	289/16°/18°	4749	150g
N8100NBP Series				
N8146NBP	352	15/47°/-9°	707	60g
N8168NBP	522	19/41°/-3°	797	65g
N8100NB-E Export Series				
N8146NB-E	454	17/40°/-5°	680	454g
N8168NB-E	676	26/31°/4°	804	454g

Model	BTU Load	Evap BTU/TD/ TEMP	Sys Cap	Refrig. Charge
N8200P Series				
N8231P	545	30/26°/-17°	759	120g
N8245P	876	46/19°/-10°	878	120g
N8259P	1208	63/20°/-11°	1274	120g
N8273P	1539	78/17°/-8°	1358	120g
N8287P	1871	95/19°/-10°	1776	150g
N8200-E Export Series				
N8231-E	379	26/42°/-7°	1112	454g
N8245-E	569	35/36°/-1°	1259	454g
N8259-E	758	43/32°/3°	1373	454g
N8273-E	948	51/29°/6°	1469	454g
N8287-E	1138	59/30°/5°	1787	454g
N8200GP Series				
N8231GP	1867	39/25°/-5°	974	120g
N8245GP	2880	59/25°/-5°	1452	120g
N8259GP	3892	79/25°/-5°	1960	150g
N8273GP	4905	99/21°/-1°	2098	150g
N8200G-E Export Series				
N8231G-E	379	26/42°/-7°	1112	454g
N8245G-E	569	35/36°/-1°	1259	454g
N8259G-E	758	43/37°/-2°	1572	454g
N8200-STP Series				
N8230-STP	532	32/23°/-17°	749	120g
N8240-STP	1063	62/15°/-9°	904	120g
N8256-STP	1078	63/19°/-13°	1220	120g
N8258-STP	1600	91/15°/-9°	1344	120g
N8275-STP	2136	121/15°/-9°	1802	150g
N8600P Series				
N8630P	465	17/47°/-11°	819	120g
N8643P	688	22/42°/-6°	923	120g
N8656P	913	27/46°/-10°	1250	120g
N8669P	1137	32/42°/-6°	1352	120g
N8681P	1361	37/46°/-10°	1690	150g
N8700D Series - NA				
N8700D-E Export Series - NA				
N8700DESP Series - NA				
N8700-D-ESP-E Export Series - NA				
N8700N Series - NA				
N8700-R Series - NA				
N8800 Series - NA				
N8800-E Export Series				

† Drop-In FlexiWell & FlexiTop Models N8600-FWP and N8200-FTP are within the FlexiWell manual 9291544



Optional Top-Off Auto Fill Installation

- Option is a loose parts kit. Field installation requires a plumber.

APPLICABLE TO N8600 & N8800 MODELS

1. Locate mounting holes on outside operator drop-in body and mount float and bracket using thumb screws.
2. Install drain plumbing as shown.
3. Connect clear plastic tubing to 1/2" copper stub and connect to the float. Use hose clamps to secure.
4. Connect fill line to 1/4" compression fitting.
5. Loosen thumb screws to achieve desired water level.

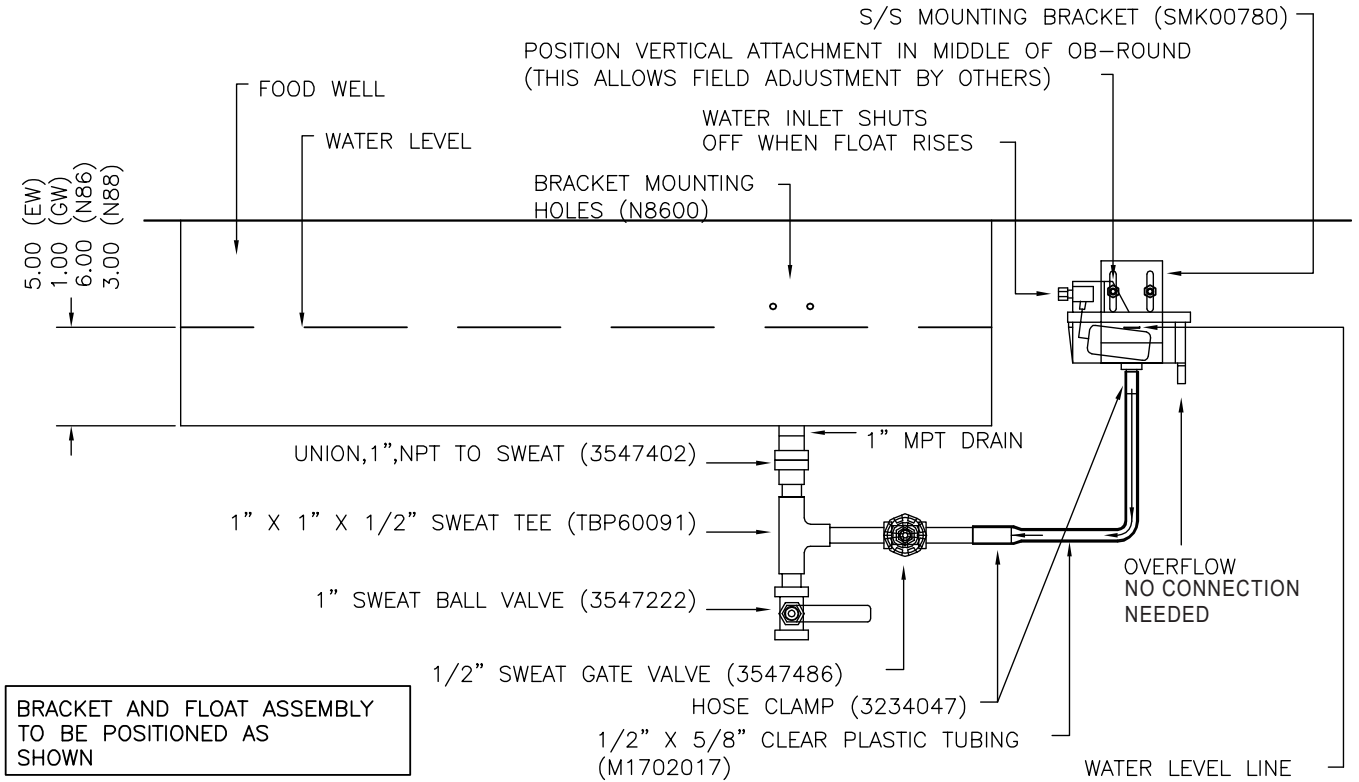

APPLICABLE TO N8700 MODELS

1. Locate mounting holes on outside operator drop-in body and mount float and bracket using thumb screws.
2. Install drain plumbing as shown.
3. Connect clear plastic tubing to 1/2" copper stub and connect to the float. Use hose clamps to secure.
4. Connect fill line to 1/4" compression fitting.
5. Loosen thumb screws to achieve desired water level.

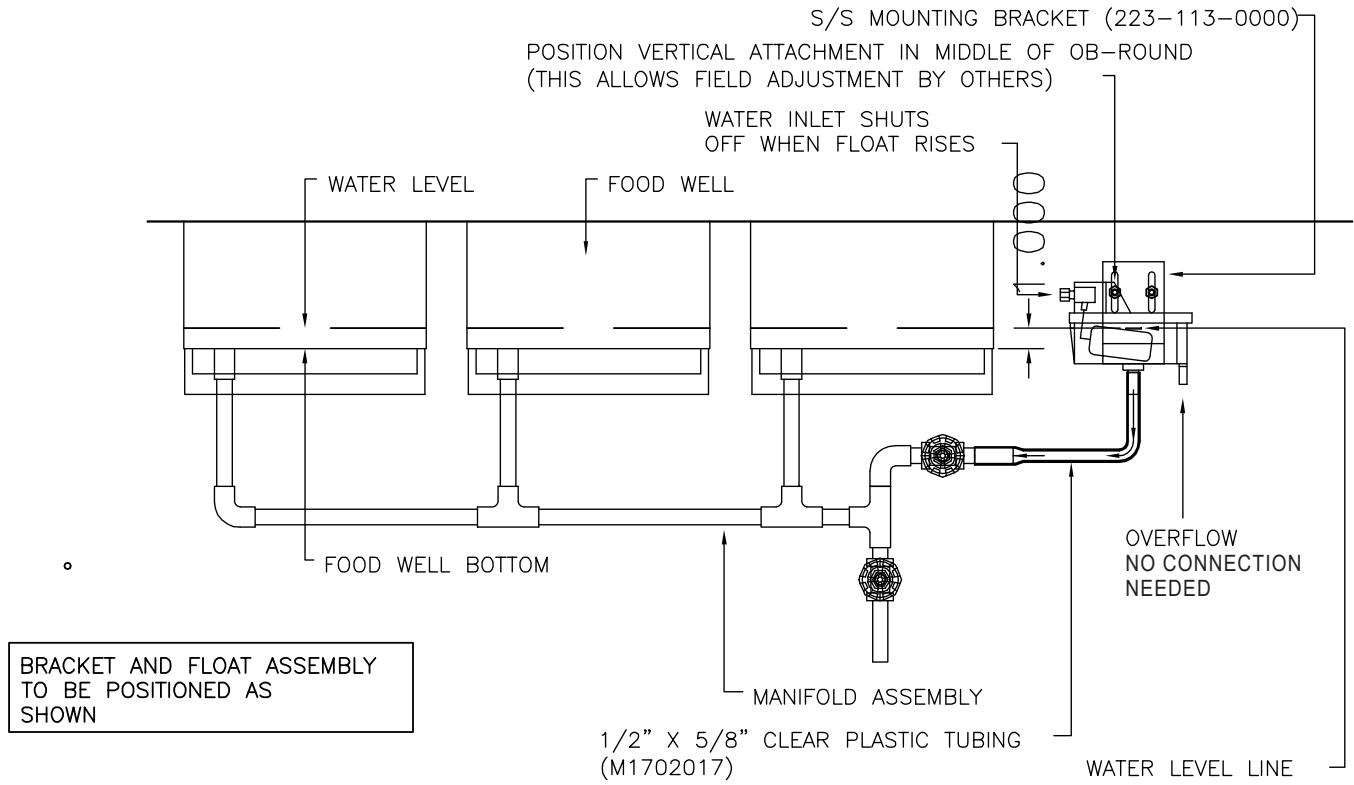

THIS PAGE INTENTIONALLY LEFT BLANK



Section 3 Operation

DANGER

The on-site supervisor is responsible for ensuring that operators are made aware of the inherent dangers of operating this equipment.

DANGER

Do not operate any appliance with a damaged cord or plug. All repairs must be performed by a qualified service company.

DANGER

Never stand on the unit! They are not designed to hold the weight of an adult, and may collapse or tip if misused in this manner.

Warning

Do not contact moving parts.

Warning

All covers and access panels must be in place and properly secured, before operating this equipment.

Warning

Damp or wet hands may stick to cold surfaces.

Warning

Never use sharp objects or tools to remove ice or frost. Do not use mechanical devices or other means to accelerate the defrosting process.

Warning

Do not block the supply and return air grills or the air space around the air grills. Keep plastic wrappings, paper, labels, etc. from being airborne and lodging in the grills. Failure to keep the air grills clear will result in unsatisfactory operation of the system.

Caution

Units with pans should be operated with pans in place. Operating the unit without all pans in place will lower efficiency and may damage the unit.

Product Quality in Cold Pans

Warning

The operator of this equipment is solely responsible for ensuring safe holding temperature levels for all food items. Failure to do so could result in unsafe food products for customers.

These units are not designed to cool warm food products. Items should be placed in the unit pre-cooled at least to the desired holding temperature, if not slightly colder. In some applications, a gradual warming of product may occur, particularly at the exposed top of the product. Stirring or rotation of the product is necessary to maintain overall temperature.

Warming of food product can occur very quickly outside of the unit. When loading or rotating product, avoid leaving food items in a non-refrigerated location for any length of time to prevent warming or spoilage. To ensure product quality product must be rotated every four hours.

Note

Drain the water from units daily for unit longevity.

8100-EF(N)P & 8100-FAP Series Operation

Note

The cold pan is not intended to be used with ice.

There is a switch on the compressor housing front to turn the 8100-EFP units on and off. The unit must be turned off when not in use or overnight for defrosting and cleaning.

8100-EFP Series LiquiTec® Eutetic fluid cold pans are adjusted at the factory to provide proper operation without any further adjustments.

The temperature control is located on the condensing housing.

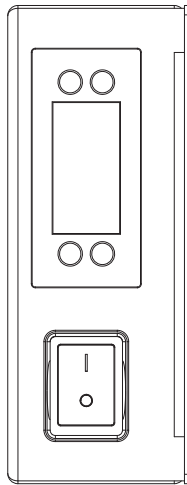

Power Switch & Temperature Control

1. At initial start-up or anytime power is disconnected, then reconnected to the unit, the control will go into normal cooling mode.
2. The temperature control will cycle the compressor and condenser fan motor to maintain proper temperature.

Notice

Temperature displayed is for refrigeration set point purposes only. Display does not reflect air or product temps in unit.

TEMPERATURE CONTROL & DISPLAY

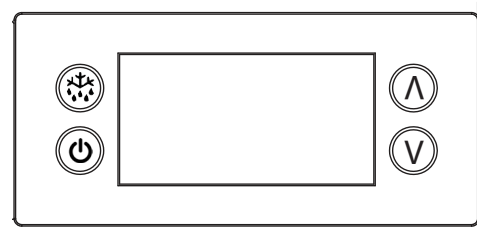

Operation / Indication			
Status	Displayed		Comments
Normal (°C)	Temp. [°C]		Unit depends on setting (parameters in control)
Normal (°F)	Temp. [°F]		
Show set-point	Temp.		
Sensor 1 defect	E01	X	Air sensor
Sensor 2 defect	E02	X	Coil sensor
Sensor 3 defect	E03	X	Open
Sensor 4 defect	E04	X	Open
High temperature alarm	Hi	X	Automatically switching at 2 sec rate
Low temperature alarm	Lo	X	
Line voltage too high, above 140 volts	uHi	X	
Line voltage too low, below 96 volts	uLi	X	
Control calls for cooling for more than 24 hours straight	LEA	X	Time includes defrost. Error will go away if the control cycles off the compressor or if the power is shut off. If error is on a cold pan it could be related to a high ambient temperature or not shutting the rail off nightly.

All alarms sound for approximately 10 seconds and then are silent for 50 seconds. It will do that for 15 cycles and then remain silent. The alarm code will still be present on the display until the fault clears.



Press upper or lower right button.

- Display show actual set-point (blinking).
 - If buttons untouched for 3 seconds returns to normal.
- Increase set-point by pressing upper button. Max value depends on parameters in control.
- Decrease set-point by pressing lower button. Min value depends on parameters in control.
 - If buttons untouched for 3 seconds returns to normal and stores new set-point.

Press lower left button for 5 seconds.

- Unit goes into stand-by mode.
 - The display will read Off, then a period.
- Press the lower left button again for 5 seconds.
 - The display will read On.
 - The unit will then start up in normal cooling mode.

Temperature Alarm

The alarm will sound and flash HI or LO 90 minutes after the unit has reached its alarm temperature point or after any power interruption if the temperature is above or below the alarm set points.

CHANGING DISPLAY FROM FAHRENHEIT TO CELSIUS ON ERC112 CONTROL

1. Simultaneously hold the up and down arrows for 5 seconds to access menu for password protected parameters.



2. Screen should temporarily flash **PAS** and then move to a numeric screen.



3. Scroll to **187** using the up/down arrows and push the stand-by button (lower left button) to enter.



4. Scroll to **dis** using the up/down arrows and push the stand-by button (lower left button) to enter into the display menu.



5. Scroll to **CFu** using the up/down arrows and push the stand-by button (lower left button) to enter the display unit menu.



6. **-F** should be displayed indicating Fahrenheit. Use the down arrow to change it to **-C** for Celsius and hit the stand-by button (lower left button) to enter the change.

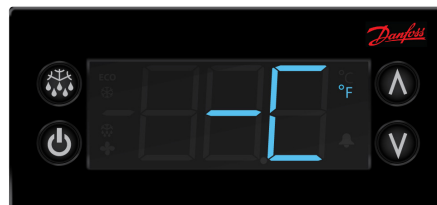

7. Push the defrost button (upper left button) to move out of the display unit menu.



8. Push the defrost button (upper left button) to move out of the display menu and back to the normal display.

NOTE: For steps 7 and 8, display will return back to normal display after 30 seconds of inactivity.



N8100BP, N8100-BRP & N8100NBP Operation

The temperature control is used to turn the unit on and off as well as control the temperature of the cold pan. The control is located in the machine compartment. To turn the cold pan off, press and hold the power button. The unit must be turned off when not in use or overnight for defrosting and cleaning.

If the cold pan is to be used with ice, it is recommended that the optional perforated bottoms be used. These will allow ice to melt properly.

N8200P & N8200-STP Operation

N8200P and N8200-STP series frost tops are designed to maintain an even layer of frost to pleasantly display product. Once turned on, the compressor will run continuously. There is no temperature control. The ON/OFF switch is the only means available to cycle the unit.

Since it takes time for the frost to accumulate initially, the unit should be turned on approximately one hour before it is required. Product should not be placed on the frost top prior to turning the unit on, because it may freeze to the surface of the unit.

The unit must be turned off when not in use or overnight for defrosting and cleaning.

Operation N8200GP

N8200GP Series granite cold slabs are designed to maintain a low temperature surface for quick turn products such as ice cream. Frost patterns will vary depending on room conditions such as temperature, humidity and airflow. The work zone of the granite surface is considered to be inside a 2.0" (5.1cm) perimeter. Temperatures in the perimeter zone may be higher and again the frost patterns in this area will vary based on room conditions.

Unit is controlled by an on/off switch. Once turned on, the unit will run continuously. There is no temperature control in this unit. Turn the unit on approximately two hours prior to use to allow for ample cool down time. At 75°F ambient temperature the unit will reach operating temperature of 0°F to 20°F in 2 hours.

The unit must be turned off when not in use or overnight for defrosting and cleaning.

8600P Hot/Cold Series Operation

Hot Operation

⚠ DANGER

When operated at the highest temperature setting, the top of the unit will become very hot. Staff and customers using the equipment should be informed about this.

⚠ Caution

Never use anything other than plain water in the wells or tank. Failure to observe this warning may result in personal injury or damage to the unit.

⚠ Caution

Using ice in a hot food well can cause condensation and damage to the well over time.

Note

Drain the water from units daily for unit longevity.

Notice

These units are intended to hold previously cooked product at a food safe temperature during time of serving. This product is **NOT** intended for cooking or increasing the temperature of held product. Improper use of unit may result in shorter unit lifespan.

N8600P Series hot and cold combination pans must be operated with water in the well for proper hot operation. Fill well with a minimum of 4.0" (10.2cm) of water. Place function switch in HOT position to begin heating. Turn thermostat dial to the desired temperature.

To turn unit off, simply move the function switch to OFF position. Drain water and allow unit to cool before cleaning or switching to cold operation.

Switching From Hot To Cold Operation

1. Place the function switch in the OFF position and drain out hot water.
2. Allow the unit to cool until it can be safely cleaned.
3. When clean up procedures are complete, unit will be ready for cold operation. This takes about one hour.

⚠ Caution

To assure maximum compressor life, do not switch from "hot" to "cold" operation without allowing a cool down period. Never switch from hot to cold operation while hot water remains in the pans. Failure to observe this warning will greatly reduce compressor life and eventually cause premature compressor failure.

⚠ Warning

Opening the drain cock will lead to the outflow of the hot contents of the bains-marie.

⚠ Warning

Wait for the water to cool to at minimum 140°F before opening the drain cock.

⚠ Warning

It is not advised or acceptable to use the refrigeration system to cool the hot water. It is also not advised to run the refrigeration system with any water in the unit.

temperature adjustment should be necessary.

If the cold pan is to be used with ice, it is recommended that the optional perforated bottoms be used. These will allow ice to melt properly.

Switching From Cold To Hot Operation

No special procedure is required to switch from the cold to hot operation. Be certain to fill with a minimum of 4.0" of water.

Note

The unit is designed so that the compressor and the heating elements cannot operate at the same time. Continued operation of the compressor in the hot position is not normal. Call for service if this happens.

The unit must be turned off when not in use or overnight for defrosting and cleaning.

N8600P Immersion Heater High Limit

As a safety feature, the N8600P food well immersion heater includes a high limit safety switch. If the heater gets too hot the safety switch will trip and turn the heater off. A pilot light on the control panel will illuminate when the safety switch is tripped. To reset the safety switch, first turn OFF the thermostat or Power switch and then determine if low water is the cause. If low water is not the cause, contact service for resolution. If low water is the cause, carefully remove food pans and refill the water. This will allow the immersion heater to cool and the safety switch will automatically reset. The unit must be turned OFF as directed or safety switch will not reset even if water is refilled to proper level. Replace food pans and turn thermostat or Power switch back on.

Cold Operation

Simply place the function switch to the COLD position. The compressor controller has been factory set and no

N8700-D, N8700N, N8700-R & N8800 Series Operation

Notice

These units are intended to hold previously cooked product at a food safe temperature during time of serving. This product is **NOT** intended for cooking or increasing the temperature of held product. Improper use of unit may result in shorter unit lifespan.

These units are designed to hold warm food product between 140°F to 160°F (60°C to 71°C).

N8700-D, N8700N and N8700-R series individually heated hot food units may be operated wet (with water in the wells) or dry. Wet operation is recommended for better performance.

N8800 Series single tank hot food units are designed to be operated wet (with water in the tank) only.

Note

Proper water level is approximately 2.0" (5.1cm). It must be maintained to prevent damage to the tank on the N8800 Series units.

After the unit is hard wired to the electrical system, select desired temperature by rotating temperature control. A knob and indicator light are provided for each individual heated food well.

First Time Use

Before the unit is used the first time for serving, turn the temperature knob to HI and heat the well for 20 to 30 minutes.

Any residue or dust that adhered to the heater element(s) will be burned off during this initial preheat period.

When serving thick sauces always use the hot food well in wet operation. This provides more uniform temperature for the sauce.

Note

Never place food directly in well. Always use pans.

For most efficient operation, keep covered inserts in each well during preheating or when empty.

Always place covers on pans when not serving to prevent food from drying out.

Wet Operation

DANGER

When operated at the highest temperature setting, the top of the unit will become very hot. Staff and customers using the equipment should be informed about this.

DANGER

Steam can cause serious burns. Always use some type of protective covering on your hands and arms when removing lids from the unit. Lift the lid in a way that will direct escaping steam away from your face and body.

Caution

Wipe wells clean of debris and metal shavings before operation. Debris left in the well may cause rust or damage to the protective stainless steel layer.

Caution

Never use anything other than plain water in the wells or tank. Failure to observe this warning may result in personal injury or damage to the unit.

Caution

Using ice in a hot food well can cause condensation and damage to the well over time.

Note

Drain the water from units daily for unit longevity.

Fill the food well with a minimum of 2.0" (5.1cm) of water and cover with lid or empty pan. To preheat water, set temperature control at HI. With pans in place, wells will boil water. Food temperature will vary depending on type and amount of product. To minimize steam and water usage, set control at lowest setting that will maintain proper food temperature. To reduce preheating time, use hot water to fill the well.

Warning

Opening the drain cock will lead to the outflow of the hot contents of the bain-marie.

Dry Operation N8700 Series only

DANGER

When operated dry, the well bottoms become very hot. Do not allow unprotected skin to contact any well surface.

Wet operation is usually much more efficient and is preferred. However, these units may be operated without water with no damage to the unit.

When operated dry, the bottom of the well will discolor. To clean, use a stainless steel cleaner or mild abrasive.

N8700-DESP Operation

Notice

These units are intended to hold previously cooked product at a food safe temperature during time of serving. This product is **NOT** intended for cooking or increasing the temperature of held product. Improper use of unit may result in shorter unit lifespan.

These units are designed to hold warm food product between 140°F to 160°F (60°C to 71°C).

N8700-DESP series individually heated hot food units may be operated wet (with water in the wells) or dry. However, dry operation using 6.0" deep pans produces optimum performance.

A power switch and digital control are provided for each individual heated food well. After the unit is hard wired to the electrical system, turn the power switch ON to energize the control; the digital display will read OFF. Press Set and then use the arrows to select the desired temperature setting (1-10). The new temperature setting is entered 3 seconds after the last button is pressed. When the power switch is used to turn the well OFF and back ON the temperature setting will remain.

Note

Never place food directly in well. Always use pans.

For most efficient operation, keep covered inserts in each well during preheating or when empty.

Always place covers on pans when not serving to prevent food from drying out.

Dry Operation

⚠ DANGER

When operated dry, the well bottoms become very hot. Do not allow unprotected skin to contact any well surface.

Dry operation is more efficient and is preferred.

When operated dry, the bottom of the well will discolor. To clean, use a stainless steel cleaner or mild abrasive.

Wet Operation

⚠ DANGER

When operated at the highest temperature setting, the top of the unit will become very hot. Staff and customers using the equipment should be informed about this.

⚠ DANGER

Steam can cause serious burns. Always use some type of protective covering on your hands and arms when removing lids from the unit. Lift the lid in a way that will direct escaping steam away from your face and body.

⚠ Caution

Never use anything other than plain water in the wells or tank. Failure to observe this warning may result in personal injury or damage to the unit.

⚠ Caution

Using ice in a hot food well can cause condensation and damage to the well over time.

⚠ Warning

Opening the drain cock will lead to the outflow of the hot contents of the bains-marie.

Fill the food well with a minimum of 2" (5cm) of water and cover with lid or empty pan. To preheat water, set temperature control at 3. With pans in place, wells will boil water. Food temperature will vary depending on type and amount of product. To minimize steam and water usage, set control at lowest setting that will maintain proper food temperature. To reduce preheating time, use hot water to fill the well. Preheating time with room temperature water is one hour.



N8700-DESP Temperature Control Operation

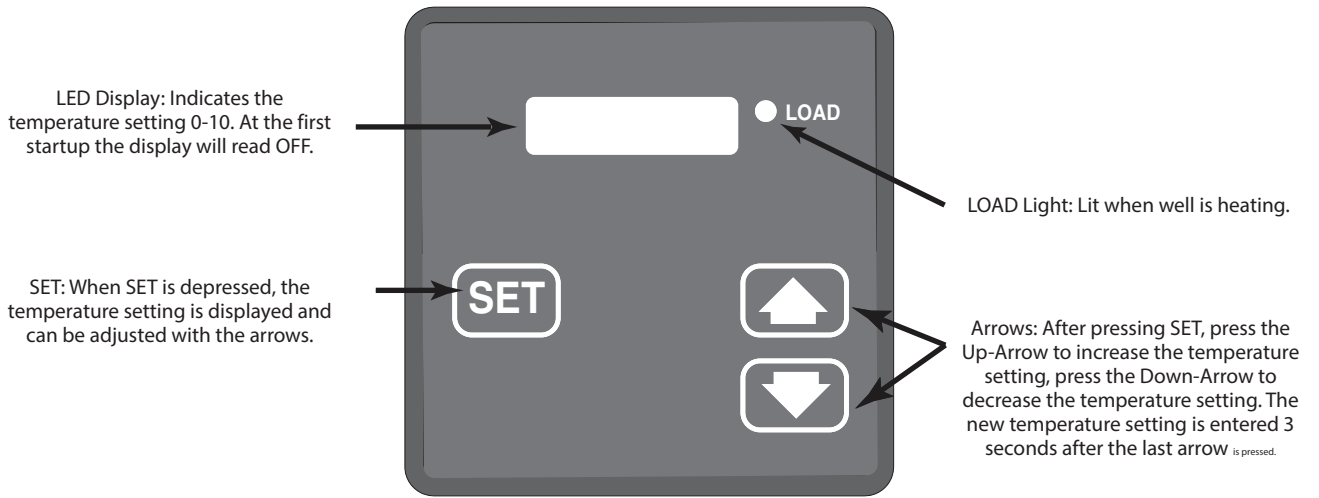

ELECTRONIC HIGH-VOLUME AUTO FILL OPTION

Wet operation units can be manufactured with an optional high-volume auto fill feature. The high-volume auto fill feature is installed with a regular garden hose and the units power. The remote lighted on/off switch will operate the water flow and allow the sensors within the well to dictate when the high-volume auto fill will need to add water into the well after normal evaporation occurs. These high-volume auto fills must be installed in the factory and cannot be installed in the field.

Electronic High-Volume Auto Fill Operation

Close the drain valve to the well. Turn the on/off switch to the on position. A 30-60 second delay will occur before the unit will begin water flow up from the drain. Once the water flow reaches the sensor, the unit will stop flow of water. YOU DO NOT NEED TO TURN THE SWITCH OFF. Heated water will evaporate and eventually lower the water level below the sensor. A 30-60 second delay will occur and then the high-volume auto fill will begin to fill the well up to the sensor. At the end of the night/shift turn the high-volume auto fill switch to the off position and drain the well with the drain valve under the well and clean the unit once cool enough to touch.

Electronic High-Volume Auto Fill Cleaning

Sensors must be free of build-up and calcium deposits. Failure to do so may result in overflow and/or malfunction. Sensors should be cleaned regularly and wells daily.

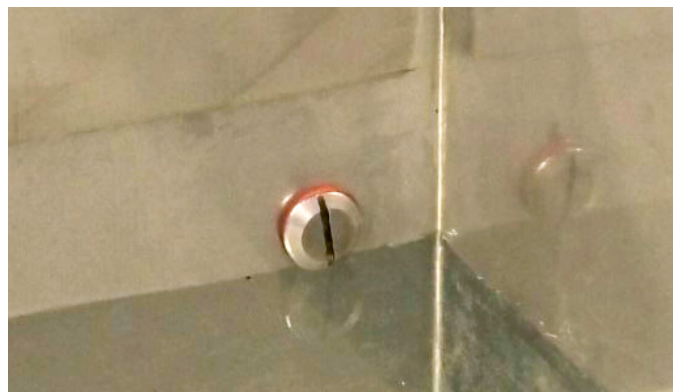

THIS PAGE INTENTIONALLY LEFT BLANK



Section 4 Maintenance

⚠ DANGER

It is the responsibility of the equipment owner to perform a personal protective equipment hazard assessment to ensure adequate protection during maintenance procedures.

⚠ DANGER

Failure to disconnect the power at the main power supply disconnect could result in serious injury or death. The power switch DOES NOT disconnect all incoming power.

⚠ DANGER

Disconnect electric power at the main power disconnect for all equipment being serviced. Observe correct polarity of incoming line voltage. Incorrect polarity can lead to erratic operation.

⚠ Warning

Never use sharp objects or tools to remove ice or frost. Do not use mechanical devices or other means to accelerate the defrosting process.

Cleaning and Sanitizing Procedures

⚠ Caution

Maintenance and servicing work other than cleaning as described in this manual must be done by an authorized service personnel.

GENERAL

⚠ Warning

When using cleaning fluids or chemicals, rubber gloves and eye protection (and/or face shield) must be worn.

You are responsible for maintaining the equipment in accordance with the instructions in this manual. Maintenance procedures are not covered by the warranty.

Maintenance	Daily	Weekly	Monthly	After Prolonged Shutdown	At Start-Up
Exterior	X			X	X
Gasket	X			X	X
N8100-FAP Series Drain		X		X	X
Condenser Coil			X	X	X



EXTERIOR CLEANING

Warning

When cleaning the unit, care should be taken to avoid the front power switch and the rear power cord. Keep water and/or cleaning solutions away from these parts.

Warning

Never use a high-pressure water jet for cleaning or hose down or flood the units with water. Do not use power cleaning equipment, steel wool, scrapers or wire brushes on stainless steel or painted surfaces.

Caution

Never use an acid based cleaning solution, including a delimer! Acid will deteriorate the finish and damage the heating element. Food products can also be acidic, keep equipment clean of ALL food products.

Clean the area around the unit as often as necessary to maintain cleanliness and efficient operation.

Gaskets require daily cleaning to prevent mold and mildew build up and also to retain the elasticity of the gasket. Gasket cleaning can be done with the use of warm soapy water (no citrus based cleaners). Avoid full strength cleaning products on gaskets as this can cause them to become brittle and crack. Never use sharp tools or knives to scrape or clean the gasket.

Wipe surfaces with a damp cloth rinsed in water to remove dust and dirt from the unit. Always rub with the "grain" of the stainless steel to avoid marring the finish. If a greasy residue persists, use a damp cloth rinsed in a mild dish soap and water solution. Wipe dry with a clean, soft cloth.

Never use steel wool or abrasive pads for cleaning. Never use chlorinated, citrus based or abrasive cleaners.

Stainless steel has a clear coating that is stain resistant and easy to clean. Products containing abrasives will damage the coating and scratch the panels. Daily cleaning may be followed by an application of stainless steel cleaner which will eliminate water spotting and fingerprints. Early signs of stainless steel breakdown are small pits and cracks. If this has begun, clean thoroughly and start to apply stainless steel cleaners in attempt to restore the steel.

N8600P Immersion Heater

Follow the same as instructions as the rest of the food well: Wipe surfaces with a damp cloth rinsed in water to remove dust and dirt from the unit. If a greasy residue persists, use a damp cloth rinsed in a mild dish soap and water solution. Wipe dry with a clean, soft cloth. Never use steel wool or abrasive pads for cleaning. Never use chlorinated, citrus based or abrasive cleaners.

Defrosting

Refrigerated cold pans **MUST** be defrosted daily. Never use sharp objects or tools to clean or scrape ice/frost build up from the refrigerated cold pans. A puncture to the pan could cause irreparable damage to the refrigeration system. Units with a Eutectic Fluid Cold Pan require the same precautions. The fluid is NOT refillable and loss of fluid due to a puncture would cause irreparable damage.

CLEANING THE CONDENSER COIL

In order to maintain proper refrigeration performance, the condenser fins must be cleaned of dust, dirt and grease regularly. It is recommended that this be done monthly. If conditions are such that the condenser is totally blocked in a month, the frequency of cleaning should be increased. Clean the condenser with a vacuum cleaner or stiff brush. If extremely dirty, a commercially available condenser cleaner may be required.

Failure to maintain a clean condenser coil can initially cause high temperatures and excessive run times. Continuous operation with a dirty or clogged condenser coil can result in compressor failure. Neglecting the condenser coil cleaning procedures will void any warranties associated with the compressor and cost to replace the compressor.

N8100-FAP SERIES DRAIN MAINTENANCE

Each N8100-FA unit has a drain located inside the unit that removes the condensation from the evaporator coil and routes it to an external condensate evaporator pan. Each drain can become loose or disconnected during normal use. If you notice water accumulation under the unit, be sure the drain tube is connected to the evaporator drain pan and the end of the drain tube is in the condensate evaporator. The leveling of the unit is important as the units are designed to drain properly when level. Be sure all drain lines are free of obstructions.

THIS PAGE INTENTIONALLY LEFT BLANK



Import:

**Germany
Welbilt Deutschland**

Auf der Weih 11
35745 Herborn
Germany
+49 2772 58050

Import:

**United Kingdom
Welbilt UK Limited**

Provincial Park, Nether Lane
Ecclesfield
Sheffield, S35 9ZX
United Kingdom
+44 1483 464900



Welbilt offers fully-integrated kitchen systems and our products are backed by KitchenCare® aftermarket parts and service. Welbilt's portfolio of award-winning brands includes Cleveland™, Convotherm®, Crem®, Delfield®, fitkitchen®, Frymaster®, Garland®, Kolpak®, Lincoln®, Manitowoc®, Merco®, Merrychef® and Multiplex®.

Bringing innovation to the table • welbilt.com