

Wireless Current Sensor

R900NA Series User Manual

Copyright©Netvox Technology Co., Ltd.

This document contains proprietary technical information which is the property of NETVOX Technology. It shall be maintained in strict confidence and shall not be disclosed to other parties, in whole or in part, without written permission of NETVOX Technology. The specifications are subject to change without prior notice.

Contents

1. Introduction	1
2. Appearance	2
3. Features	4
4. Setup Instructions	5
5. Data Report	7
5.1 Example of ReportDataCmd	8
5.2 Example of ConfigureCmd	10
5.3 Example of SetSensorAlarmThresholdCmd	13
5.4 Example of GlobalCalibrateCmd	15
5.5 Example of NetvoxLoRaWANRejoin	16
5.6 Example for MinTime/MaxTime logic	18
6. NFC App	20
7. Installation	23
8. Battery Passivation	29
9. Important Maintenance Instructions	29

1. Introduction

A wireless current sensor in R900NA series can support up to 6 detachable or non-detachable current transformers (CT), 4 point-contact NTC thermistors, 1 digital output/input, 1 light sensor, and a built-in vibration sensor. In addition to these powerful functions, the R900NAB series supports configuration and firmware upgrade through Netvox NFC App. The devices integrate built-in vibration sensors for tamper detection and support one output/input signal, enabling threshold-alarm-triggered control of third-party devices.

LoRa Wireless Technology

LoRa is a wireless communication technology famous for its long-distance transmission and low power consumption. Compared with other communication methods, LoRa spread spectrum modulation technique greatly extends the communication distance. It can be widely used in any case that requires long-distance and low-data wireless communications. For example, automatic meter reading, building automation equipment, wireless security systems, and industrial monitoring. It has features like small size, low power consumption, long transmission distance, strong anti-interference ability, and so on.

LoRaWAN

LoRaWAN uses LoRa technology to define end-to-end standard specifications to ensure interoperability between devices and gateways from different manufacturers.

2. Appearance

R900NAB607T4 for example:

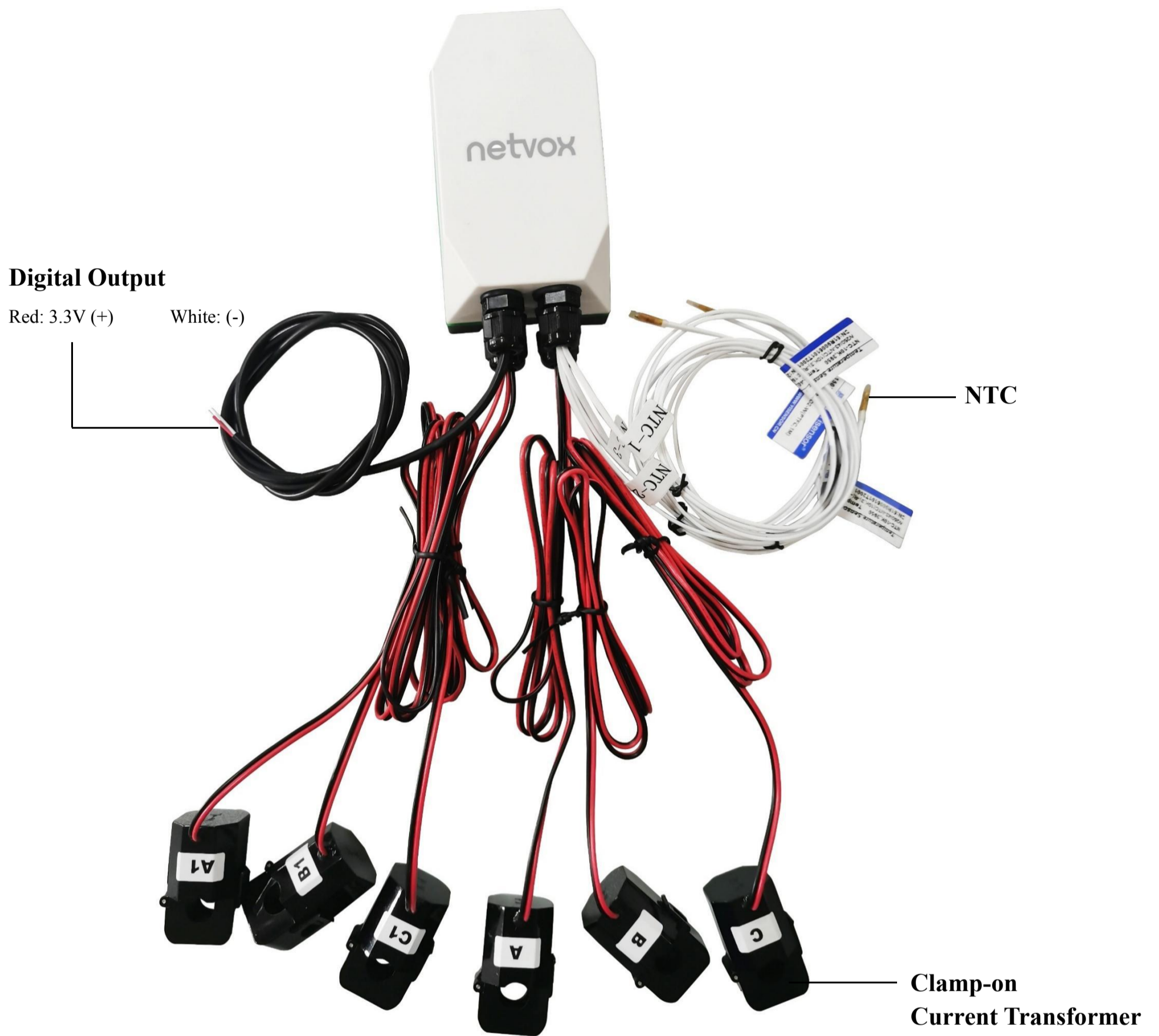



NFC

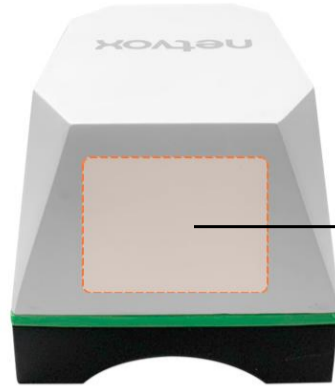

Magnetic switch

Top



Left Side



Back

3. Features

- Equipped with multiple kinds of sensors
(Up to 6* clamp-on CTs + up to 4* NTC thermistor + 1* digital output + 1* light sensor +1* built-in vibration sensor)
- CT cable (detachable/undetachable), measurement range (75/150/250A...), phase (single / 3-phase) can be personalized based on user's need
- For AC detection
- Support NFC. Configure and upgrade firmware on Netvox NFC app
- Store up to 10000 data
- Report when device disconnects from the network
- Output digital signal based on the threshold of current and temperature
- Support magnetic switch to turn on/off and factory reset device
- Powered by 2* 3.6V ER18505 batteries (also support ER14505 batteries with battery converter case), or DC 12V
- Up to 7 installation methods for different kinds of scenarios
- Main unit: IP53; Sensor: IP30
- LoRaWAN™ Class A compatible
- Frequency hopping spread spectrum
- Applicable to the third-party platforms: Actility/ThingPark, TTN, MyDevices/Cayenne
- Low power consumption and longer battery life

4. Setup Instructions

On / Off

Power on	Insert 2* 3.6V ER18505 batteries or connect a DC adapter
Power off	Remove the batteries / DC adapter.

Function key

Turn on	Press and hold the function key for 3 seconds until the green indicator flashes once.
Turn off	Step 1. Press and hold the function key for 5 seconds until the green indicator flashes once. Step 2. Release the function key and short press it in 5 seconds. Step 3. The green indicator flashes 5 times. R900 turns off.
Factory reset	Step 1. Press and hold the function key for 10 seconds. The green indicator flashes once every 5 seconds. Step 2. Release the function key and short press it in 5 seconds. Step 3. The green indicator flashes 20 times. R900 is factory reset and off.

Magnetic switch

Turn on	Hold a magnet near R900 for 3 seconds until the green indicator flashes once.
Turn off	Step 1. Hold a magnet close to R900 for 5 seconds. The green indicator flashes once. Step 2. Remove the magnet and get close to R900 in 5 seconds. Step 3. The green indicator flashes 5 times. R900 turns off.
Factory reset	Step 1. Hold a magnet close to R900 for 10 seconds. The green indicator flashes once every 5 seconds. Step 2. Remove the magnet and get close to R900 in 5 seconds. Step 3. The green indicator flashes 20 times. R900 is factory reset and off.

Note:

- a. Remove and insert the battery; the device is off by default.
- b. 5 seconds after powering on, the device will be in engineering test mode.
- c. The on/off interval should be about 10 seconds to avoid the interference of capacitor inductance and other energy storage components.
- d. After the batteries are removed, the device can still operate for a while until the power supported by the supercapacitor runs out.

Join a Network

First time joining the network	<p><u>Turn on the device to search the network.</u></p> <p>The green indicator stays on for 5 seconds: Success</p> <p>The green indicator remains off: Fail</p>
Had joined the network before (Device is not factory reset.)	<p><u>Turn on the device to search the network.</u></p> <p>The green indicator stays on for 5 seconds: Success</p> <p>The green indicator remains off: Fail</p>
Fail to join the network	<p>(1) Please turn off the device and remove the batteries to save power.</p> <p>(2) Please check the device verification information on the gateway or consult your platform server provider.</p>

Function key

Short press	<p><u>Device is in the network</u></p> <p>The green indicator flashes once. 6 seconds after sampling is completed, the device reports a data packet.</p> <p><u>Device is not in the network</u></p> <p>The green indicator remains off.</p>
-------------	---

Note: The function key does not work during sampling.

Magnetic switch

Move magnet close to the switch and remove it	<p><u>Device is in the network</u></p> <p>The green indicator flashes once. 6 seconds after sampling is completed, the device reports a data packet.</p> <p><u>Device is not in the network</u></p> <p>The green indicator remains off.</p>
---	---

Sleep Mode

The device is on and in the network.	<p>Sleeping period: Min Interval.</p> <p>When the reportchange exceeds the setting value or the state changes: send a data report based on the Min Interval.</p>
--------------------------------------	--

Low Voltage Alarm

Low voltage	3.3V
-------------	------

Note: To ensure the accuracy of data, please replace the battery when it drops to low voltage.

5. Data Report

35 seconds after the device is powered on, it will send a version packet and data including CT's current (mA) and NTC's temperature (0.1°C).

Default setting:

Min Interval = 0x0E10 (3600s)

Max Interval = 0x0E10 (3600s) // should not be less than 30 seconds

CurrentChange= 0x0064 (100 mA)

TemperatureChange = 0x001E (3°C)

Current Transformer Measurement Range and Accuracy:

	75A	150A	250A	630A	1000A	3000A
Measurement Range	100mA – 75A	1A – 150A	1A – 250A	5A – 630A	10A – 1000A	150A – 3000A
Accuracy	±1% (300mA–75A)	±1%				

Note: a. Current transformer reports 0A when the current < 1A.

b. If no configuration is done, the device sends data based on the default settings.

c. Please refer to Netvox LoRaWAN Application Command document and Netvox Lora Command Resolver

<http://www.netvox.com.cn:8888/cmddoc> to resolve uplink data.

Data report configuration and sending period are as follows:

Min Interval (unit: second)	Max Interval (unit: second)	Reportable Change	Current Change ≥ Reportable Change	Current Change < Reportable Change
Any number between 30 to 65535	Any number between Min time to 65535	Cannot be 0	Report per Min Interval	Report per Max Interval

5.1 Example of ReportDataCmd

FPort: 0x16

(The above is in hexadecimal. To use decimal, please convert it to port 22.)

Bytes	1	2	1	Var (length according to the payload)
	Version	DeviceType	ReportType	NetvoxPayloadData

Version – 1 bytes – 0x03—the Version of NetvoxLoRaWAN Application Command Version

DeviceType – 2 bytes – Device Type of Device

The devicetype is listed in Netvox LoRaWAN Application Devicetype V3.0.doc

ReportType – 1 byte – the presentation of the NetvoxPayloadData according to the devicetype

NetvoxPayloadData – Var bytes (length according to the payload)

Tips

1. Battery Voltage

The voltage value is bit 0 – bit 6, bit 7=0 is normal voltage, and bit 7=1 is low voltage.

Battery=0xA1, binary= 1010 0001, if bit 7= 1, it means low voltage.

The actual voltage is 0010 0001 = 0x21 = 33, 33*0.1v =3.3v.

2. Version Packet

When Report Type = 0x00 is the version packet, such as 030105000A0320250115, the firmware version is 2025.01.15.

3. Data Packet

When Report Type=0x01 is the data packet.

4. Signed Value

When the temperature is negative, 2's complement should be calculated.

Device	Device Type	Report Type	NetvoxPayLoadData												
R900NAB 6T4	0x0104	0x01	Battery (1 Byte, unit: 0.1v)	Current1 (3 Bytes, unit: mA)	Current2 (3 Bytes, unit: mA)	Current3 (3 Bytes, unit: mA)	Current4 (3 Bytes, unit: mA)	Current5 (3 Bytes, unit: mA)	Current6 (3 Bytes, unit: mA)	Temperature 1 (Signed 2 Bytes, unit: 0.1°C)	Temperature 2 (Signed 2 Bytes, unit: 0.1°C)	Temperature 3 (Signed 2 Bytes, unit: 0.1°C)	Temperature 4 (Signed 2 Bytes, unit: 0.1°C)	ThresholdAlarm (3 Bytes) Bit0:LowCurrent1Alarm Bit1:HighCurrent1Alarm Bit2:LowCurrent2Alarm Bit3:HighCurrent2Alarm Bit4:LowCurrent3Alarm Bit5:HighCurrent3Alarm Bit6:LowCurrent4Alarm Bit7:HighCurrent4Alarm Bit8:LowCurrent5Alarm Bit9:HighCurrent5Alarm Bit10:LowCurrent6Alarm Bit11:HighCurrent6Alarm Bit12:LowTemp1Alarm Bit13:HighTemp1Alarm Bit14:LowTemp2Alarm Bit15:HighTemp2Alarm Bit16:LowTemp3Alarm Bit17:HighTemp3Alarm Bit18:LowTemp4Alarm Bit19:HighTemp4Alarm Bit20_23: Reserved	ShockTamper Alarm (1 Byte, 0x00_NoAlarm, 0x01_Alarm)
R900NAB 6T4O	0x0105														
R900NAB 6T1O	0x010C														
R900NAB 3T1O	0x010D														

Example of Uplink: **0301050122001D4C 001D55 001C99 03D090 03D870 03D070 00DC00DC00DD00DF00000801**

1st Byte (03): Version

2nd 3rd Byte (0105): DeviceType— R900NAB6T4O

4th (01): ReportType

5th Byte (22): Battery—3.4V 22 (Hex) = 34 (Dec), 34* 0.1v = 3.4V

6th – 8th Byte (001D4C): Current1—7500mA 1D4C (Hex) = 7500 (Dec), 7500* 1mA = 7500mA

9th – 11th Byte (001D55): Current2—7509mA 1D55 (Hex) = 7509 (Dec), 7509* 1mA = 7509mA

12th – 14th Byte (001C99): Current3—7321mA 1C99 (Hex) = 7321 (Dec), 7321* 1mA = 7321mA

15th – 17th Byte (03D090): Current4—250000mA 3D090 (Hex) = 250000, 250000* 1mA = 250000mA

18th – 20th Byte (03D870): Current5—252016mA 3D870 (Hex) = 252016 (Dec), 252016* 1mA = 252016mA

21th – 23th Byte (03D070): Current6—249968mA 000000 (Hex) = 249968 (Dec), 249968* 1mA = 249968mA

24th – 25th Byte (00DC): Temperature1—22.0°C 00DC (Hex) = 220 (Dec), 220* 0.1°C = 22.0°C

26th – 27th Byte (00DC): Temperature2—22.0°C 00DC (Hex) = 220 (Dec), 220* 0.1°C = 22.0°C

28th – 29th Byte (00DD): Temperature3—22.1°C 00DD (Hex) = 221 (Dec), 221* 0.1°C = 22.1°C

30th – 31th Byte (00DF): Temperature4—22.3°C 00DF (Hex) = 223 (Dec), 223* 0.1°C = 22.3°C

32th – 34th Byte (000008): Threshold Alarm—High Current2 Alarm

35th Byte (01): ShockTamperAlarm —Alarm

Note: Current and Temperature reports 0xFFFFFFFF or 0xFFFF when no sensor is connected. For example, Current4, 5, and 6 report 0xFFFFFFFF when R900 only has 3 CTs connected.

5.2 Example of ConfigureCmd

FPort: 0x17

(The above is in hexadecimal. To use decimal, please convert it to port 23.)

Bytes	1	2	Var (length according to the payload)
	CmdID	DeviceType	NetvoxPayLoadData

CmdID – 1 byte

DeviceType – 2 bytes – Device Type of Device

The devicetype is listed in **Netvox LoRaWAN Application Devicetype3.0.doc**

NetvoxPayLoadData– var bytes Var bytes (length according to the payload)

Description	Device	CmdID	Device Type	NetvoxPayLoadData				
ConfigReport Req	R900NAB 6T4	0x01	0x0104	MinTime (2 Bytes, unit: s)	MaxTime (2 Bytes, unit: s)	Current Change (2 Bytes, unit: 1mA)	Temperature Change (2 Bytes, unit: 0.1°C)	
ConfigReport Rsp		0x81		Status (0x00_success)				
ReadConfig ReportReq		0x02	0x0105	MinTime (2 Bytes, unit: s)	MaxTime (2 Bytes, unit: s)	Current Change (2 Bytes, unit: 1mA)	Temperature Change (2 Bytes, unit: 0.1°C)	
ReadConfig ReportRsp		0x82						
SetShockSensorSensitivity Req		R900NAB 6T10	0x03	0x010C	ShockSensorSensitivity (1 Byte)			
SetShockSensorSensitivity Rsp		R900NAB 3T10	0x83	0x010D	Status (0x00_success)			
GetShockSensorSensitivity Req			0x04					
GetShockSensorSensitivity Rsp			0x84		ShockSensorSensitivity (1 Byte)			

(1) Configure device parameters

MinTime = 0x003C (60s), MaxTime = 0x003C (60s),

CurrentChange = 0x0064 (100mA), TemperatureChange = 0x001E (3°C)

Downlink: 010105003C003C0064001E

Response: 81010500 (configuration success)

81010501 (configuration fail)

Read device parameters

Downlink: 020105

Response: 820105003C003C0064001E

(2) Configure ShockSensorSensitivity = 0x14 (20)

Downlink: 03010514

Response: 83010500 (configuration success)

83010501 (configuration fail)

Note: ShockSensorSensitivity range = 0x01 to 0x14
0xFF (disables vibration sensor)

Read ShockSensorSensitivity

Downlink: 040105

Response: 84010514 (device's current parameters)

Description	Device	CmdID	Device Type	NetvoxPayLoadData		
Config DigitalOutput Req	R900NAB 6T4O	0x05	0x0105	DigitalOutPutType (1 Byte) 0x00_NormallyLowLevel, 0x01_NormallyHighLevel	OutPulseTime (1 Byte, unit: s)	BindAlarmSource (3 Bytes) Bit0_LowCurrent1Alarm, Bit1_High Current1Alarm, Bit2_LowCurrent2Alarm, Bit3_High Current2Alarm, Bit4_LowCurrent3Alarm, Bit5_High Current3Alarm, Bit6_LowCurrent4Alarm, Bit7_High Current4Alarm, Bit8_LowCurrent5Alarm, Bit9_High Current5Alarm, Bit10_LowCurrent6Alarm, Bit11_High Current6Alarm, Bit12_LowTemp1Alarm, Bit13_HightTemp1Alarm, Bit14_LowTemp2Alarm, Bit15_HightTemp2Alarm, Bit16_LowTemp3Alarm, Bit17_HightTemp3Alarm, Bit18_LowTemp4Alarm, Bit19_HightTemp4Alarm, Bit20-23: Reserved
	R900NAB 6T1O		0x010C			
	R900NAB 3T1O		0x010D			
Config DigitalOutput Rsp		0x85		Status (0x00_success)		



Read Config DigitalOutput Req		0x06			
Read Config DigitalOutput Rsp		0x86	DigitalOutPutType (1 Byte) 0x00_NormallyLowLevel, 0x01_NormallyHighLevel	OutPulseTime (1 Byte, unit: s)	BindAlarmSource (3 Bytes) Bit0_LowCurrent1Alarm, Bit1_High Current1Alarm, Bit2_LowCurrent2Alarm, Bit3_High Current2Alarm, Bit4_LowCurrent3Alarm, Bit5_High Current3Alarm, Bit6_LowCurrent4Alarm, Bit7_High Current4Alarm, Bit8_LowCurrent5Alarm, Bit9_High Current5Alarm, Bit10_LowCurrent6Alarm, Bit11_High Current6Alarm, Bit12_LowTemp1Alarm, Bit13_HightTemp1Alarm, Bit14_LowTemp2Alarm, Bit15_HightTemp2Alarm, Bit16_LowTemp3Alarm, Bit17_HightTemp3Alarm, Bit18_LowTemp4Alarm, Bit19_HightTemp4Alarm, Bit20-23: Reserved)
TriggerDigital OutputReq		0x07		OutPulseTime (1 Byte, unit: s)	
TriggerDigital OutputRsp		0x87		Status (0x00_success)	

(3) Configure DigitalOutPutType = 0x00 (NormallyLowLevel),

OutPulseTime = 0xFF (disable pulse duration),

BindAlarmSource = 0x002000 (HightTemp1Alarm = 1)

(0010 0000 0000 0000 (BIN) // When HightTemp1Alarm is triggered, digital outputs signals.

Downlink: 05010500FF002000

Response: 85010500 (configuration success)

85010501 (configuration fail)

Read DO parameters

Downlink: 060105

Response: 86010500FF002000

Configure OutPulseTime = 0x0A (10 seconds)

Downlink: 0701050A00

Response: 87010500 (configuration success)

5.3 Example of SetSensorAlarmThresholdCmd

FPort: 0x10

(The above is in hexadecimal. To use decimal, please convert it to port 16.)

CmdDescriptor	CmdID (1 Byte)	Payload (10 Bytes)			
SetSensorAlarm ThresholdReq	0x01	Channel (1 Byte) 0x00_Channel1, 0x01_Chanel2, 0x02_Channel3, etc.	SensorType (1 Byte) 0x00_Disable ALL 0x01_Temperature 0x27_Current	SensorHighThreshold (4 Bytes) unit: Current – 1mA Temperature – 0.1°C	SensorLowThreshold (4 Bytes) unit: Current – 1mA Temperature – 0.1°C
SetSensorAlarm ThresholdRsp	0x81	Status (0x00_success)		Reserved (9 Bytes, Fixed 0x00)	
GetSensorAlarm ThresholdReq	0x02	Channel (1 Byte) 0x00_Channel1, 0x01_Chanel2, 0x02_Channel3, etc.	SensorType (1 Byte) 0x00_Disable ALL 0x01_Temperature 0x27_Current	Reserved (8 Bytes, Fixed 0x00)	
GetSensorAlarm ThresholdRsp	0x82	Channel (1Byte) 0x00_Channel1, 0x01_Chanel2, 0x02_Channel3, etc.	SensorType (1 Byte) 0x00_Disable ALL 0x01_Temperature 0x27_Current	SensorHighThreshold (4 Bytes) unit: Current – 1mA Temperature – 0.1°C	SensorLowThreshold (4 Bytes) unit: Current – 1mA Temperature – 0.1°C

Note:

- Current Channel: 0x00 – 0x05; SensorType: 0x27
Temperature Channel: 0x00 – 0x03; SensorType: 0x01
- Set SensorHigh/LowThreshold as 0xFFFFFFFF to disable threshold.
- The last configuration will be saved when the device is reset to factory setting.

(1) Configure parameters

Channel = 0x00, SensorType = 0x27 (Current),

SensorHighThreshold = 0x000003E8 (1000mA), SensorLowThreshold = 0x00000064 (100mA)

Downlink: 010027000003E800000064

Response: 810000000000000000000000 (configuration success)

810100000000000000000000 (configuration fail)

(2) Read parameters

Downlink: 020027000000000000000000

Response: 820027000003E800000064 (device's current parameters)

(3) Configure parameters

Channel = 0x00, SensorType = 0x01 (Temperature),

SensorHighThreshold = 0x000003E8 (100°C), SensorLowThreshold = 0x00000064 (10°C)

Downlink: 010027000003E800000064

Response: 810000000000000000000000 (configuration success)

810100000000000000000000 (configuration fail)

(4) Read parameters

Downlink: 020001000000000000000000

Response: 820001000003E800000064 (device's current parameters)



5.4 Example of GlobalCalibrateCmd

Fport: 0x0E

Description	Cmd ID	SensorType	PayLoad (Fix = 9 Bytes)					
SetGlobalCalibrate Req	0x01	0x01_Temperature Sensor	Channel (1 Byte) 0_Channel1 1_Channel2, etc.	Multiplier (2 Bytes, Unsigned)	Divisor (2 Bytes, Unsigned)	DeltValue (2 Bytes, Signed)	Reserved (2 Bytes, Fixed 0x00)	
SetGlobalCalibrate Rsp	0x81		Channel (1 Byte) 0_Channel1 1_Channel2, etc.	Status (1 Byte) 0x00_success)	Reserved (7 Bytes, Fixed 0x00)			
GetGlobalCalibrate Req	0x02		Channel (1 Byte) 0_Channel1 1_Channel2, etc.	Reserved (8 Bytes, Fixed 0x00)				
GetGlobalCalibrate Rsp	0x82		Channel (1 Byte) 0_Channel1 1_Channel2, etc.	Multiplier (2 Bytes, Unsigned)	Divisor (2 Bytes, Unsigned)	DeltValue (2 Bytes, Signed)	Reserved (2 Bytes, Fixed 0x00)	
ClearGlobalCalibrate Req	0x03	Reserved (10 Bytes, Fixed 0x00)						
ClearGlobalCalibrate Rsp	0x83	Status (1 Byte, 0x00_success)	Reserved (9 Bytes, Fixed 0x00)					

SensorType: 0x01_Temperature Sensor; Channel: 0x00 – 0x03

※ " Current " does not support calibration.

(1) SetGlobalCalibrateReq

Calibrate temperature sensor by increasing 10°C

Channel: 0x00 (channel1); Multiplier: 0x0001 (1); Divisor: 0x0001 (1); DeltValue: 0x0064 (100)

Downlink: 0101000001000000640000

Response: 81010000000000000000 (configuration success)

8101000100000000000000 (configuration fail)

(2) Read parameters

Downlink: 0201000000000000000000

Response: 8201000001000000640000 (configuration success)

(3) ClearGlobalCalibrateReq

Downlink: 030000000000000000000000

Response: 830000000000000000000000

5.5 Example of NetvoxLoRaWANRejoin

Fport:0x20

(The above is in hexadecimal. To use decimal, please convert it to port 32.)

Check if the device is connected to the network during RejoinCheckPeriod. If the device does not respond within the RejoinThreshold, it will be rejoined back to the network automatically.

CmdDescriptor	CmdID (1 Byte)	Payload (Var Bytes)						
SetNetvoxLoRaWAN RejoinReq	0x01	RejoinCheckPeriod (4 Bytes, unit: 1s)				RejoinThreshold (1 Byte)		
SetNetvoxLoRaWAN RejoinRsp	0x81	Status (1 Byte) 0x00_success				Reserved (4 Bytes, Fixed 0x00)		
GetNetvoxLoRaWAN RejoinReq	0x02	Reserved (5 Bytes, Fixed 0x00)						
GetNetvoxLoRaWAN RejoinRsp	0x82	RejoinCheckPeriod (4 Bytes, unit: 1s)				RejoinThreshold (1 Byte)		
SetNetvoxLoRaWAN RejoinTimeReq	0x03	1 st Rejoin Time (2 Bytes, unit:1 min)	2 nd Rejoin Time (2 Bytes, unit: 1 min)	3 rd Rejoin Time (2 Bytes, unit: 1 min)	4 th Rejoin Time (2 Bytes, unit: 1 min)	5 th Rejoin Time (2 Bytes, unit: 1 min)	6 th Rejoin Time (2 Bytes, unit: 1 min)	7 th Rejoin Time (2 Bytes, unit: 1 min)
SetNetvoxLoRaWAN RejoinTimeRsp	0x83	Status (1 Byte) 0x00_success				Reserved (13 Bytes, Fixed 0x00)		
GetNetvoxLoRaWAN RejoinTimeReq	0x04	Reserved (15 Bytes, Fixed 0x00)						
GetNetvoxLoRaWAN RejoinTimeRsp	0x84	1 st Rejoin Time (2 Bytes, unit:1 min)	2 nd Rejoin Time (2 Bytes, unit: 1 min)	3 rd Rejoin Time (2 Bytes, unit: 1 min)	4 th Rejoin Time (2 Bytes, unit: 1 min)	5 th Rejoin Time (2 Bytes, unit: 1 min)	6 th Rejoin Time (2 Bytes, unit: 1 min)	7 th Rejoin Time (2 Bytes, unit: 1 min)

Note:

- a. Set RejoinCheckThreshold as 0xFFFFFFFF to stop the device from rejoining the network.
- b. The last configuration would be kept when the device is factory reset.
- c. Default setting:
RejoinCheckPeriod = 2 (hr) and RejoinThreshold = 3 (times)
1st Rejoin Time = 0x0001 (1 min), 2nd Rejoin Time = 0x0002 (2 mins), 3rd Rejoin Time = 0x0003 (3 mins),
4th Rejoin Time = 0x0004 (4 mins), 5th Rejoin Time = 0x003C (60 mins), 6th Rejoin Time = 0x0168 (360 mins),
7th Rejoin Time = 0x05A0 (1440 mins)
- d. If device loses connection from network before data are reported, the data will be saved and reported every 30 seconds after the device is reconnected. Data will be reported based on the format of Payload + Unix timestamp. After all data are reported, the report time will be back to the normal setting.

(1) Command Configuration

Set RejoinCheckPeriod = 0x00000E10 (3600s), RejoinThreshold = 0x03 (3 times)

Downlink: 0100000E1003

Response: 810000000000 (Configuration success)

810100000000 (Configuration failure)

(2) Read RejoinCheckPeriod and RejoinThreshold

Downlink: 020000000000

Response: 8200000E1003

(3) Configure Rejoin Time

1st Rejoin Time = 0x0001 (1 min), 2nd Rejoin Time = 0x0002 (2 mins), 3rd Rejoin Time = 0x0003 (3 mins),

4th Rejoin Time = 0x0004 (4 mins), 5th Rejoin Time = 0x0005 (5 mins), 6th Rejoin Time = 0x0006 (6 mins),

7th Rejoin Time = 0x0007 (7 mins)

Downlink: 030001000200030004000500060007

Response: 83000000000000000000000000000000 (Configuration success)

83010000000000000000000000000000 (Configuration failure)

(4) Read Rejoin Time parameter

Downlink: 04000000000000000000000000000000

Response: 840001000200030004000500060007

5.6 Example for MinTime/MaxTime logic

Example#1 based on MinTime = 1 hour, MaxTime = 1 hour, Reportable Change i.e. BatteryVoltageChange = 0.1V

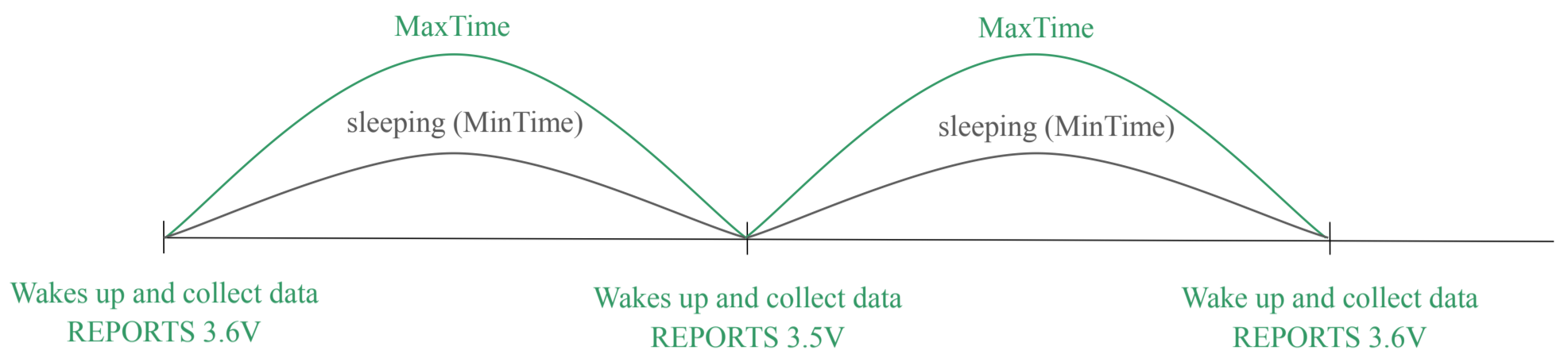

Note: MaxTime = MinTime. Data will only be reported according to MaxTime (MinTime) duration regardless BatteryVoltageChange value.

Example#2 based on MinTime = 15 minutes, MaxTime = 1 hour, Reportable Change i.e. BatteryVoltageChange = 0.1V.

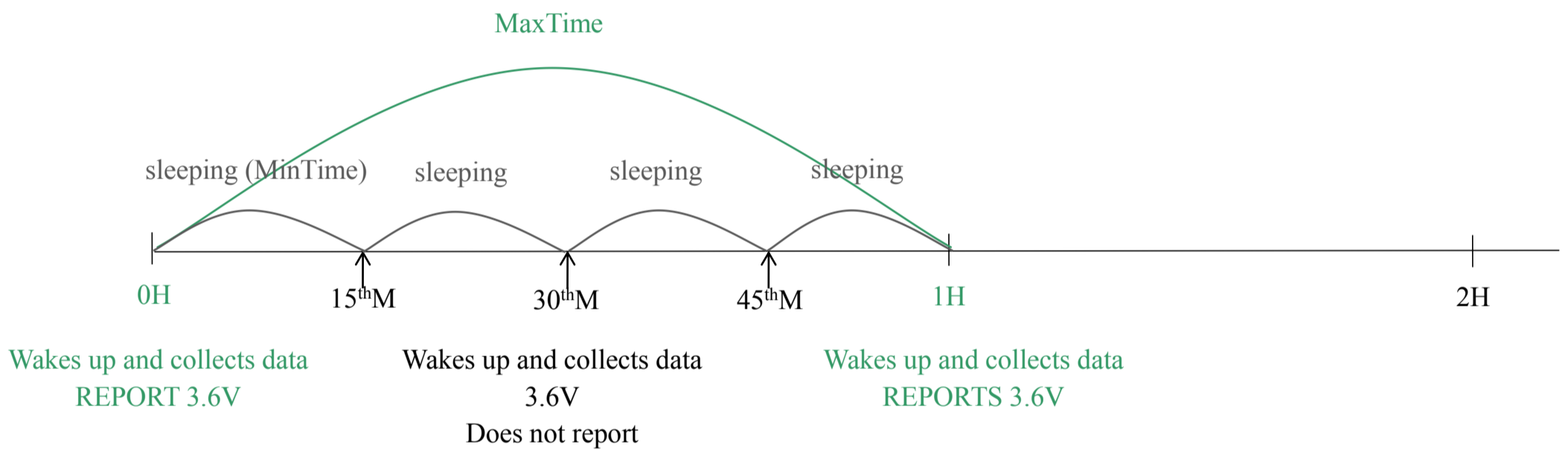

Example#3 based on MinTime = 15 minutes, MaxTime = 1 hour, Reportable Change i.e. BatteryVoltageChange = 0.1V.

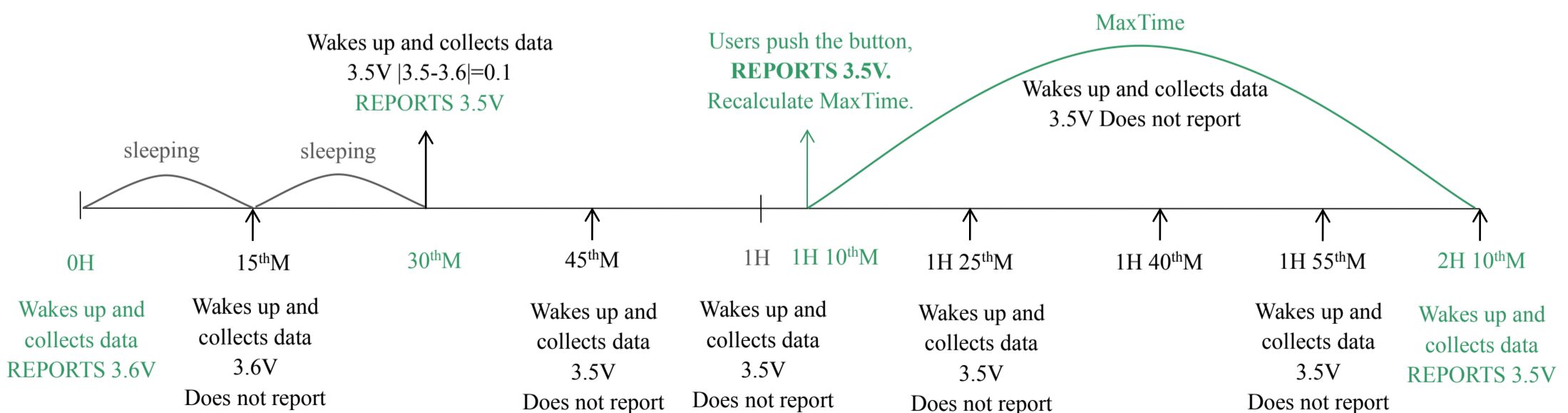

Notes:

- a. The device only wakes up and performs data sampling according to MinTime Interval. When it is sleeping, it does not collect data.
- b. The data collected is compared with the last data reported. If the data variation is greater than the ReportableChange value, the device reports according to MinTime interval. If the data variation is not greater than the last data reported, the device reports according to MaxTime interval.
- c. We do not recommend setting the MinTime Interval value too low. If the MinTime Interval is too low, the device wakes up frequently and the battery will be drained soon.
- d. Whenever the device sends a report, no matter resulting from data variation, button pushed or MaxTime interval, another cycle of MinTime/MaxTime calculation is started.

6. NFC App

(1) Download Netvox NFC app.

Please make sure your phone supports NFC.

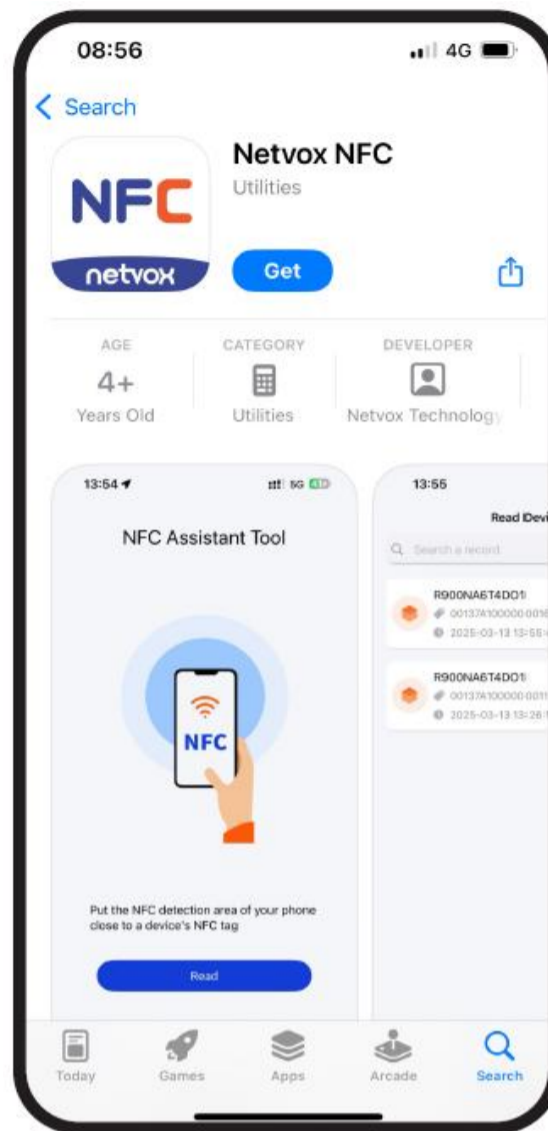

(2) Enable NFC in Settings and find your phone's NFC area.

Open the app and click Read.

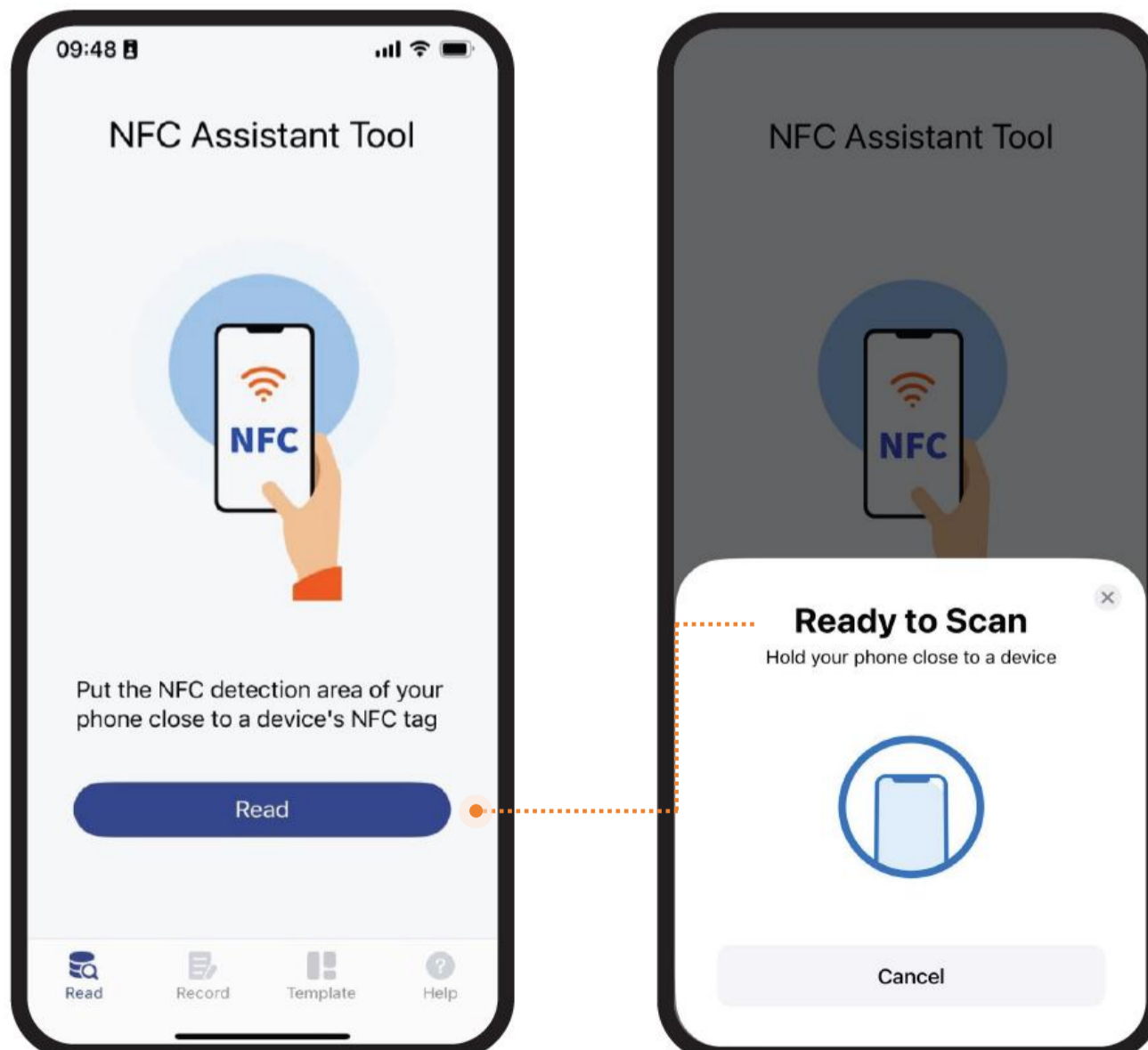

(3) Hold your phone near R900's NFC tag.

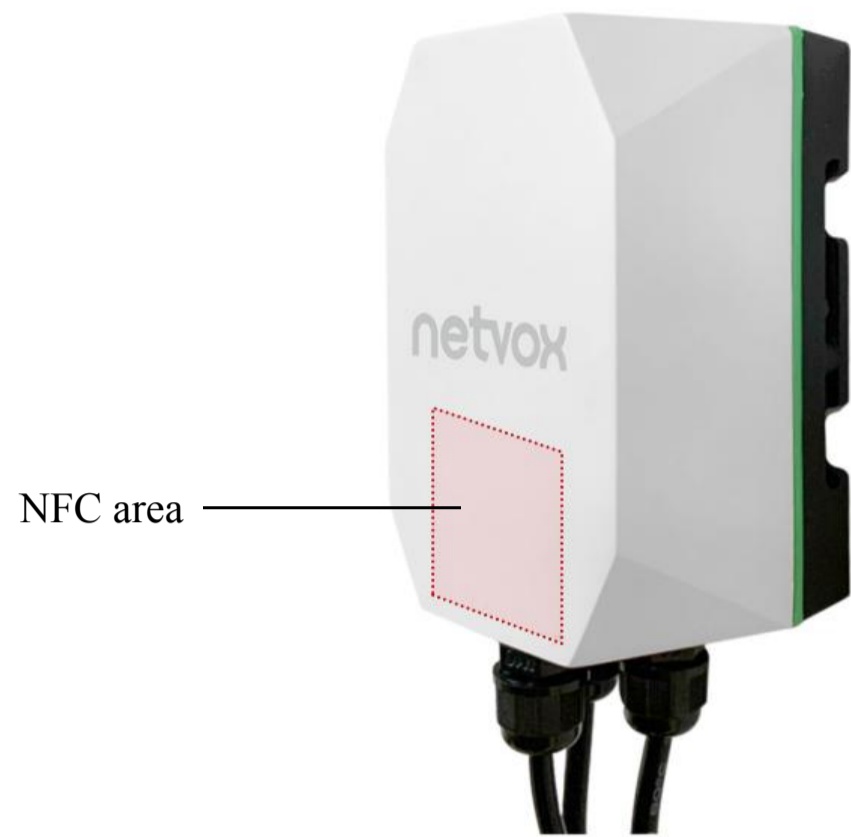

(4) After R900 is successfully read, the latest 10 data will be displayed.

Select a data and go to the Data processing.

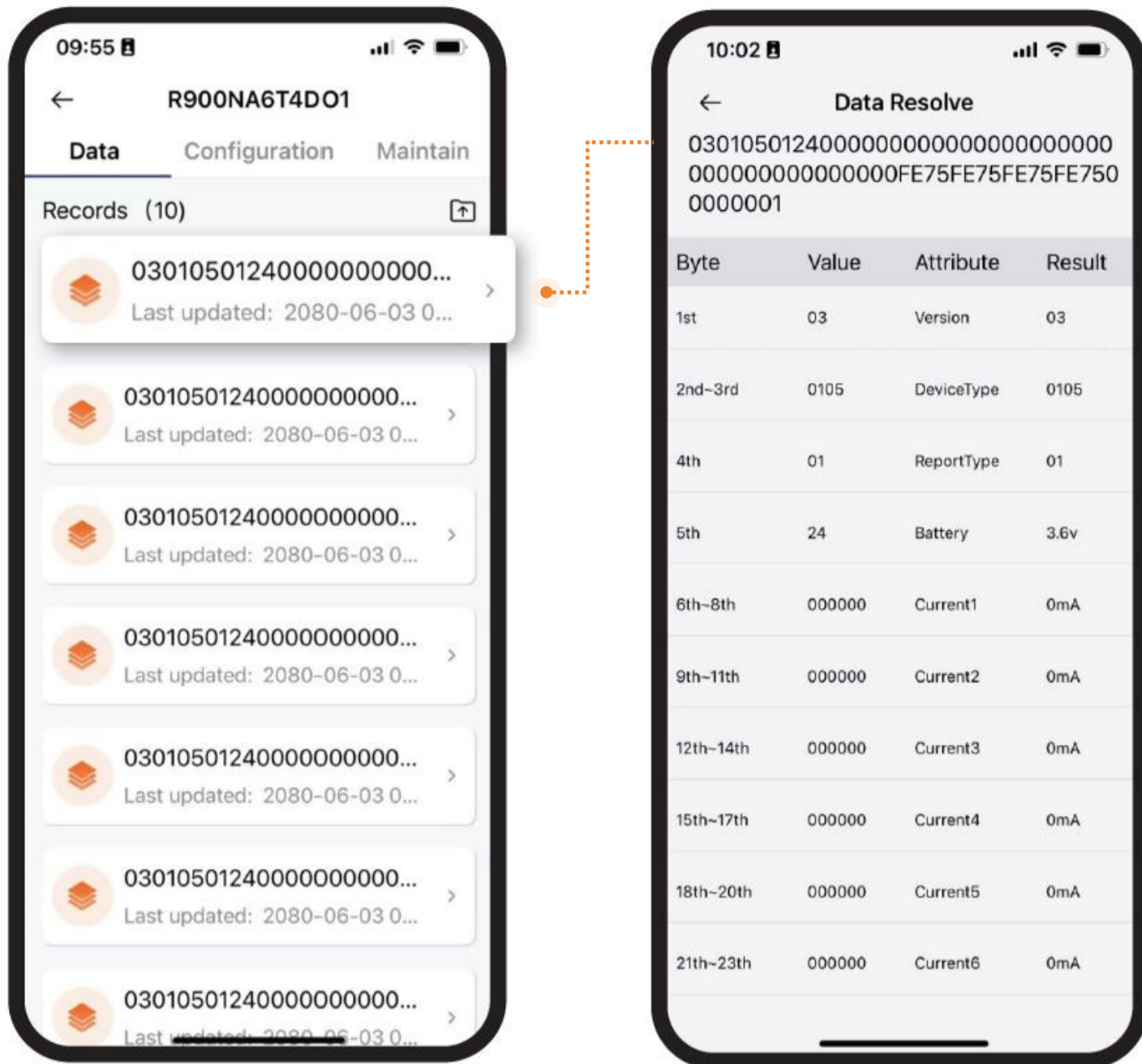

7. Installation

R900

- Standard

(1) Screws + Bracket

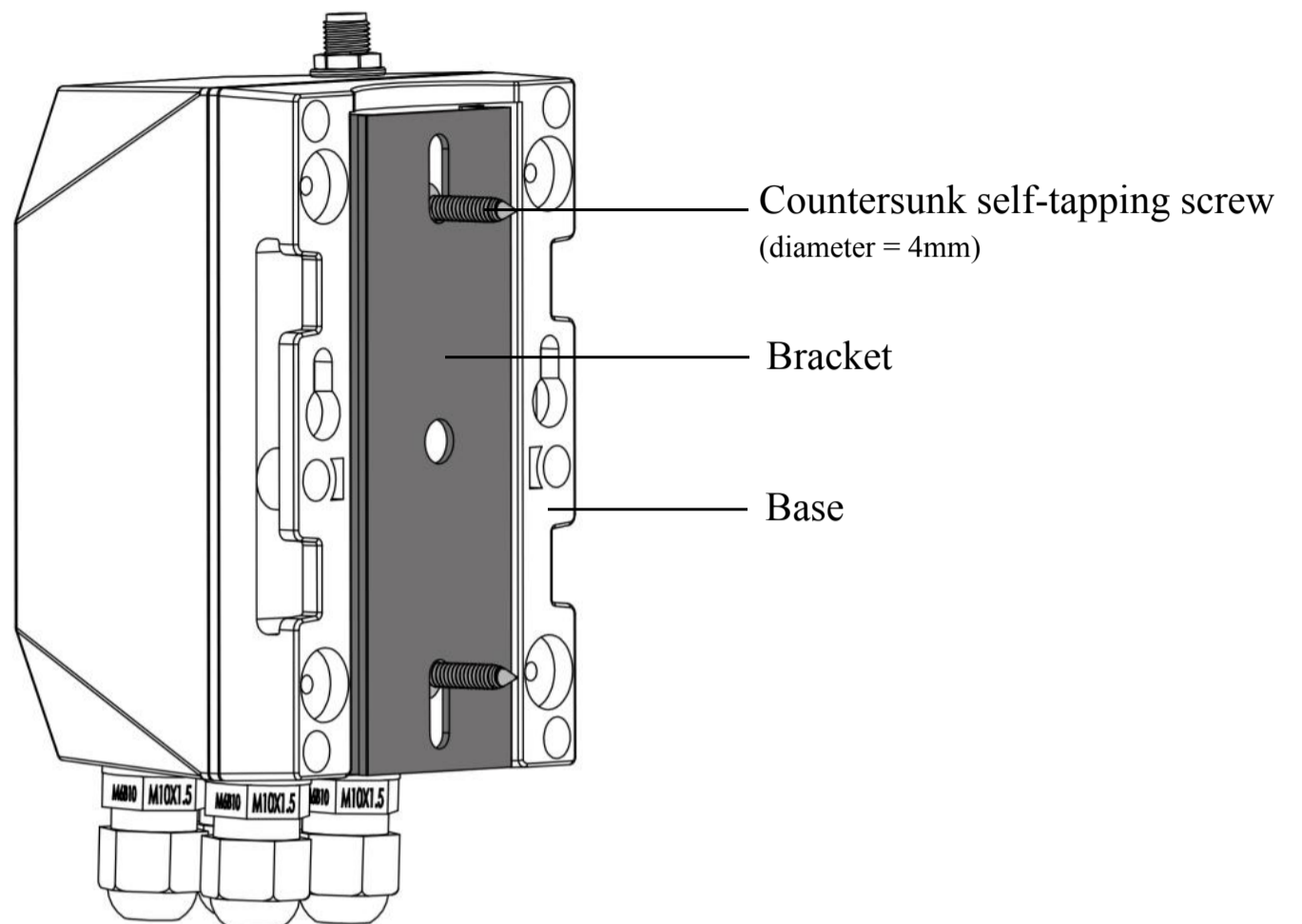

- 1 Mount the bracket on a surface with 2 counter self-tapping screws.
- 2 Hold R900 and slide down to connect the base and bracket.

(2) Screws

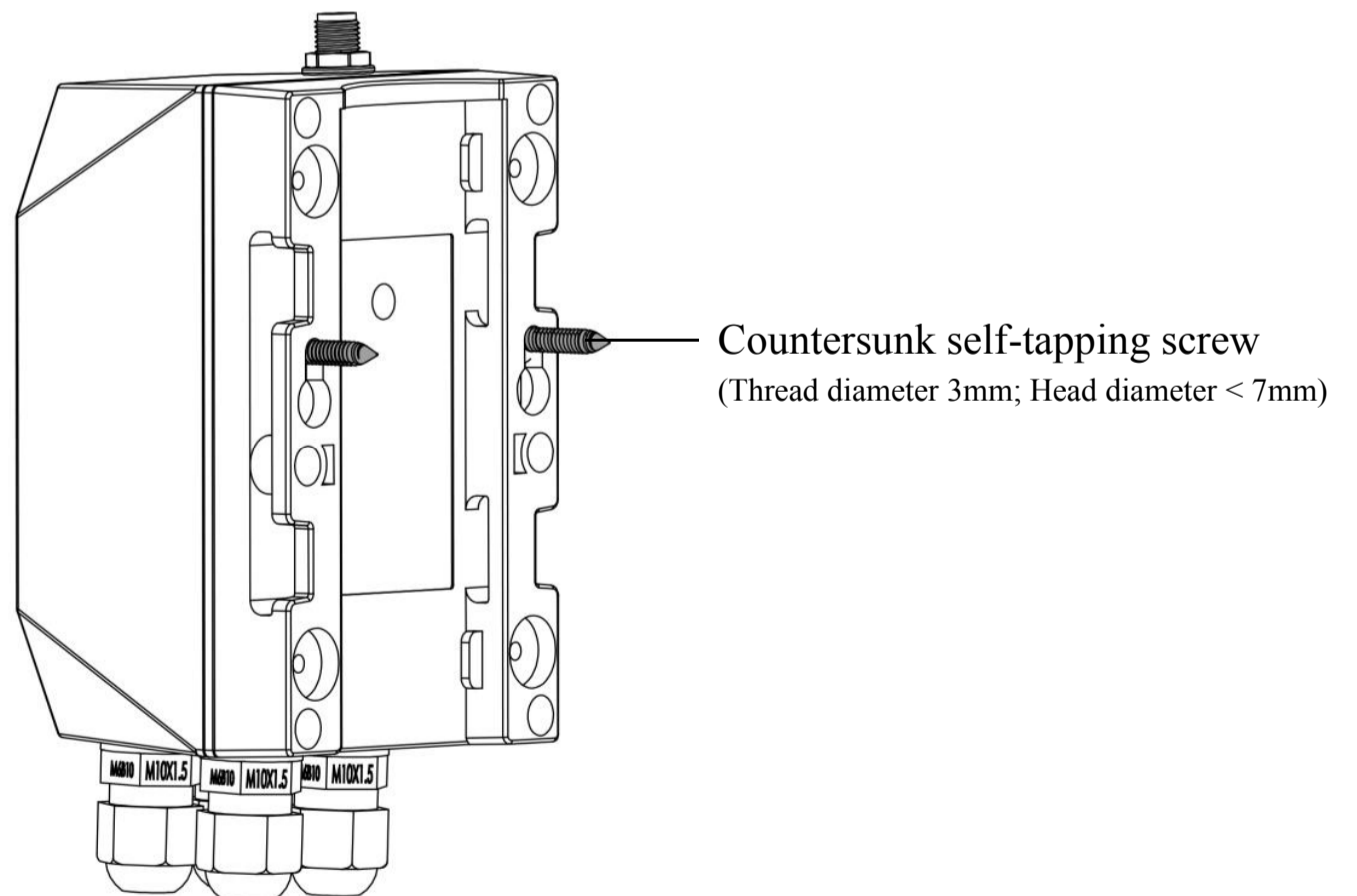

- 1 Mount 2 countersunk self-tapping screws or expansion bolts on the wall.
The distance between the two screws should be 48.5mm. The gap between the bottom of the screw head and the wall should be 3mm.
- 2 After the screws are mounted, align the holes of the base with the screws.
- 3 Move R900 down to clamp it.

(3) Double-Sided Tape

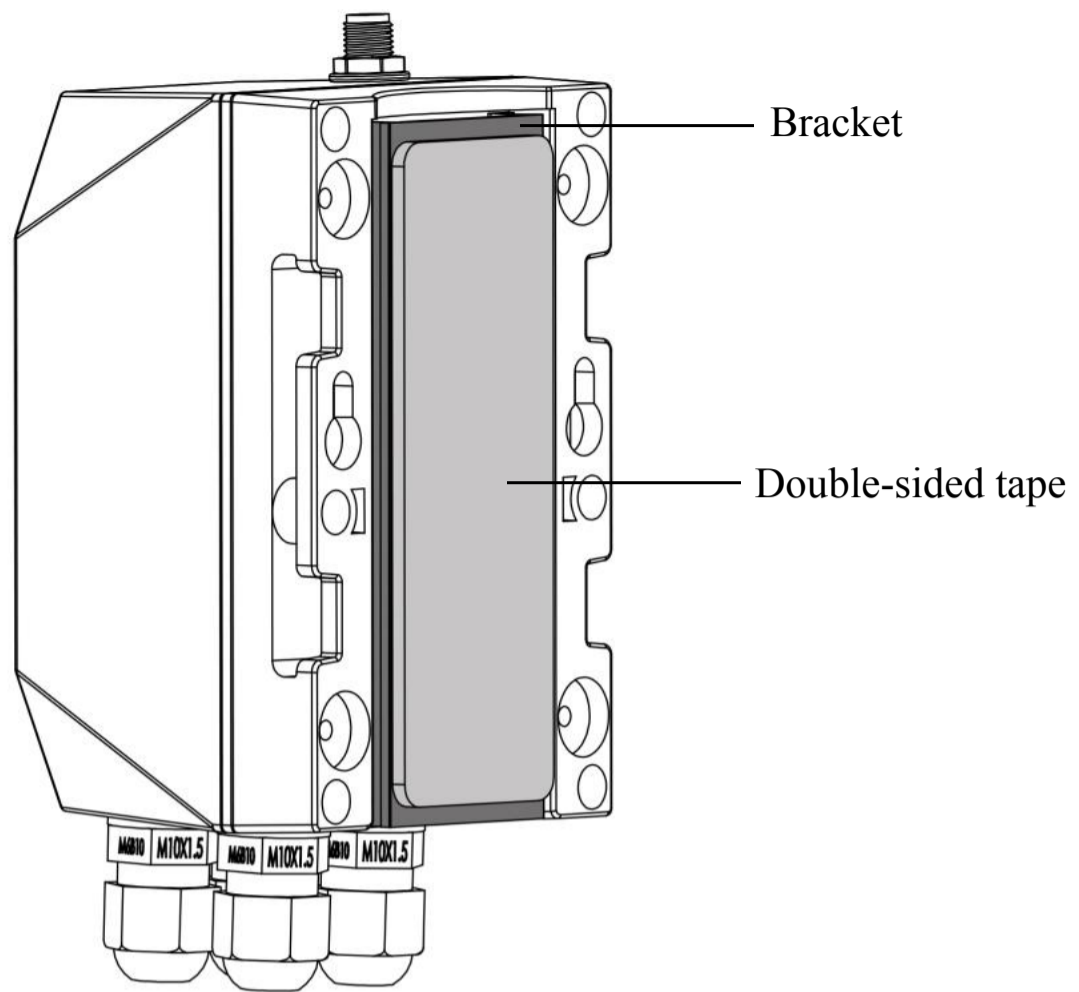

- 1 Stick the double-sided tape on the bracket.
- 2 Peel the liner and fix R900 on the surface.
- 3 Press to ensure R900 is firmly installed.

Note: Please make sure the surface is clean and dry before applying double-sided tape.

- Optional

(1) Magnet

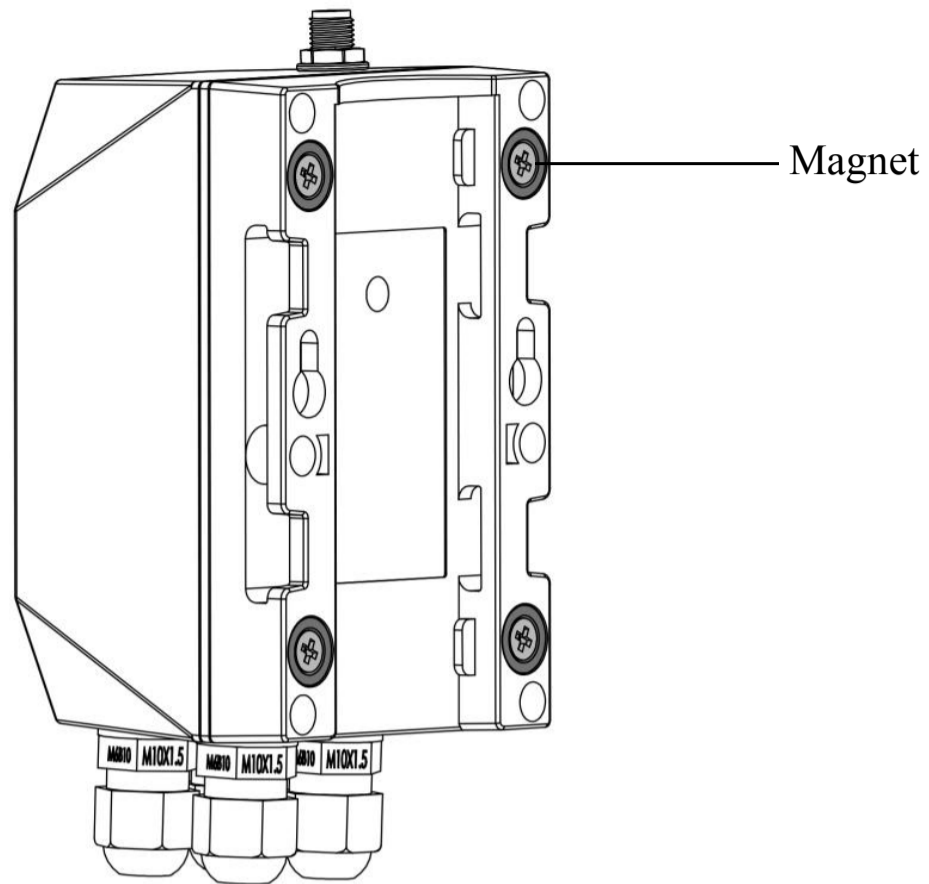

- 1 Fix the R900 on a metal surface.

(2) Swivel Bracket

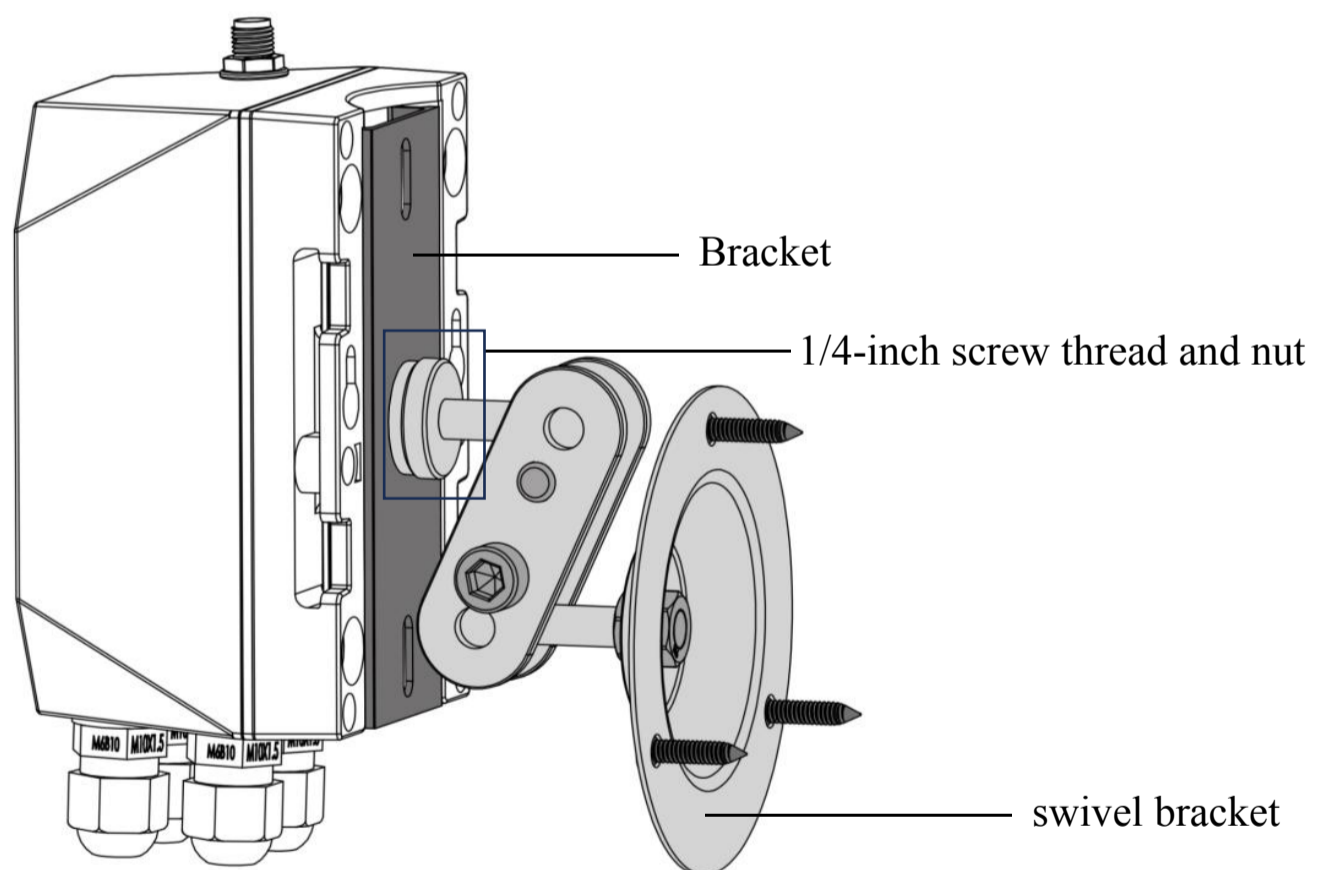

- 1 Insert a 1/4-inch screw thread into the hole of the bracket.
- 2 Tighten the thread with a nut.
- 3 Mount the swivel bracket with self-tapping screws and expansion bolts.
- 4 Hold R900 and slide down to connect the base and bracket.

(3) DIN Rail

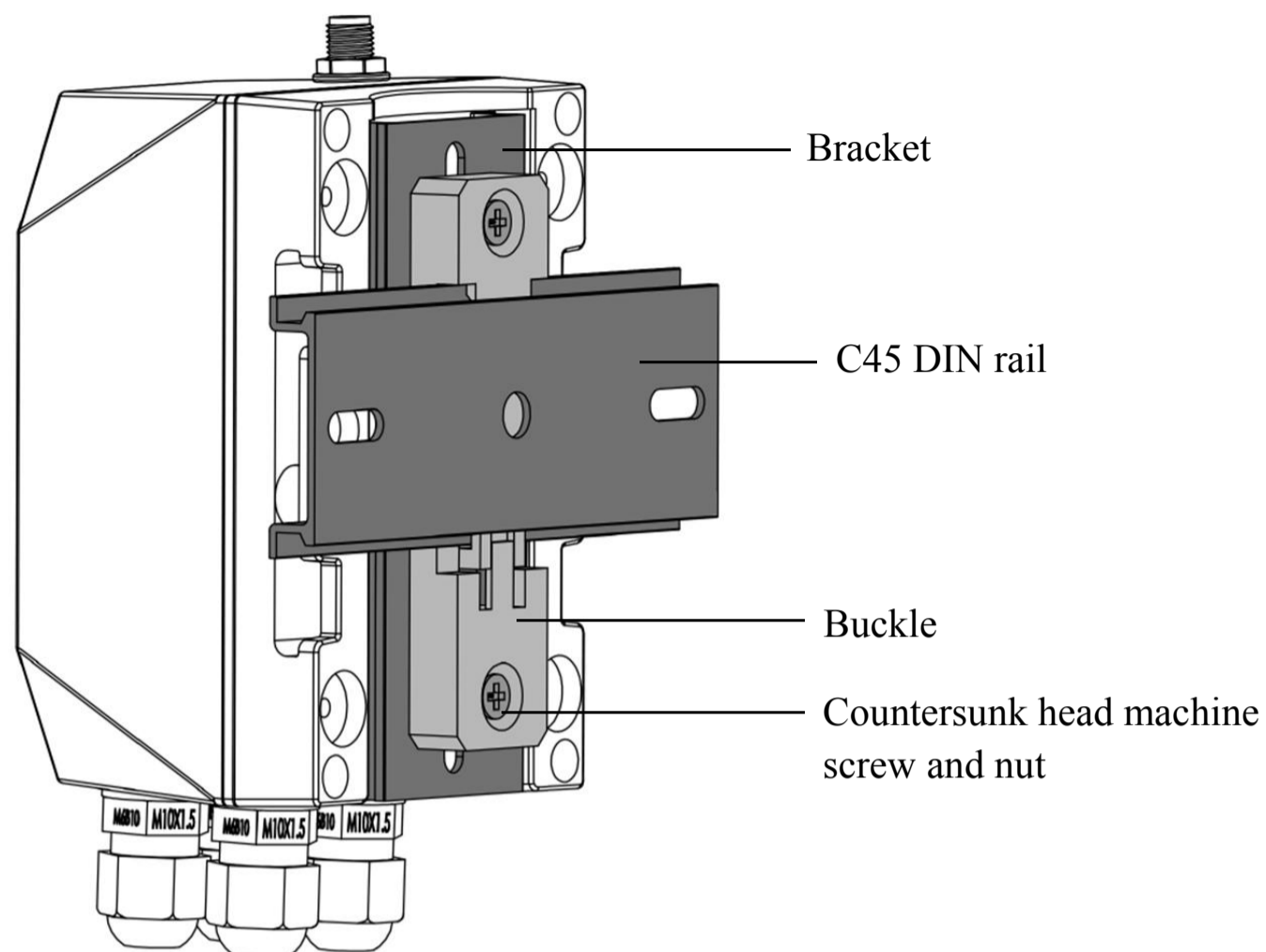

- 1 Mount the rail buckle onto R900's bracket with countersunk head machine screws and nuts.
- 2 Snap the buckle onto the DIN rail.
- 3 Hold R900 and slide down to connect the base and bracket.

● Prepared by customers

(1) Cable Tie

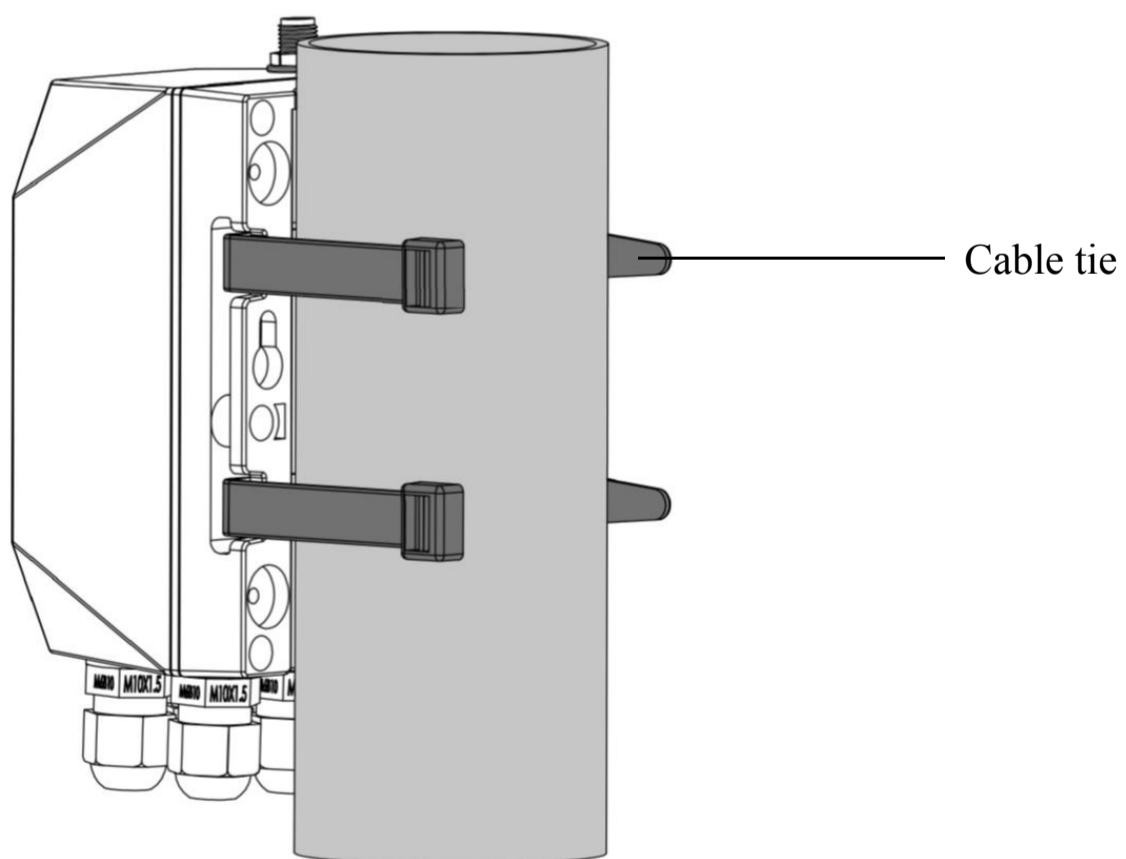

- 1 Insert cable ties through the holes of the base.
- 2 Insert the pointed end through the slot.
- 3 Tighten the cable ties and make sure R900 is fixed firmly around a column.

Current Transformer

- 1 Open the clip of a current transformer.
- 2 Separate live and neutral wires.
- 3 Put a live wire in a clip and close it.

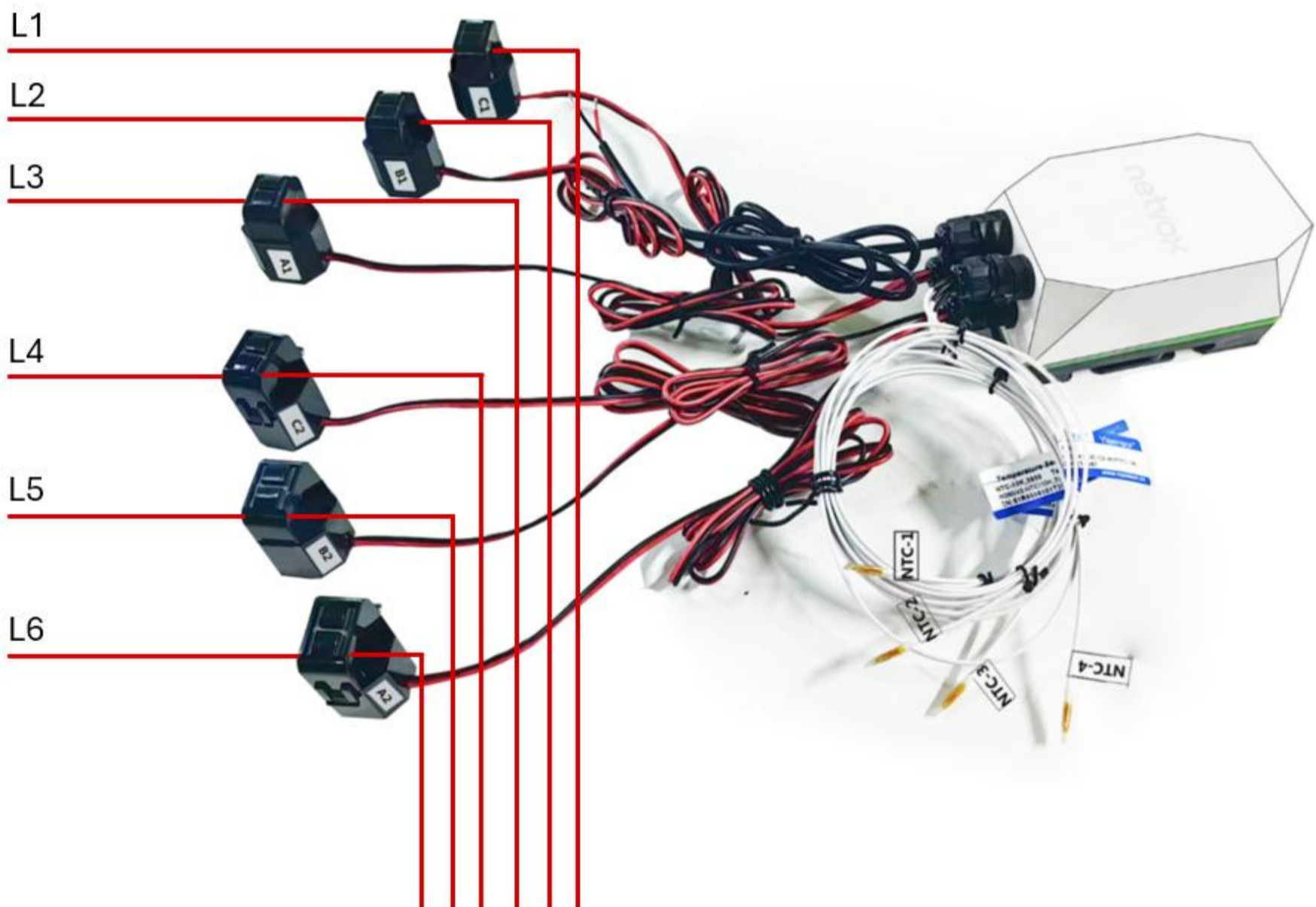
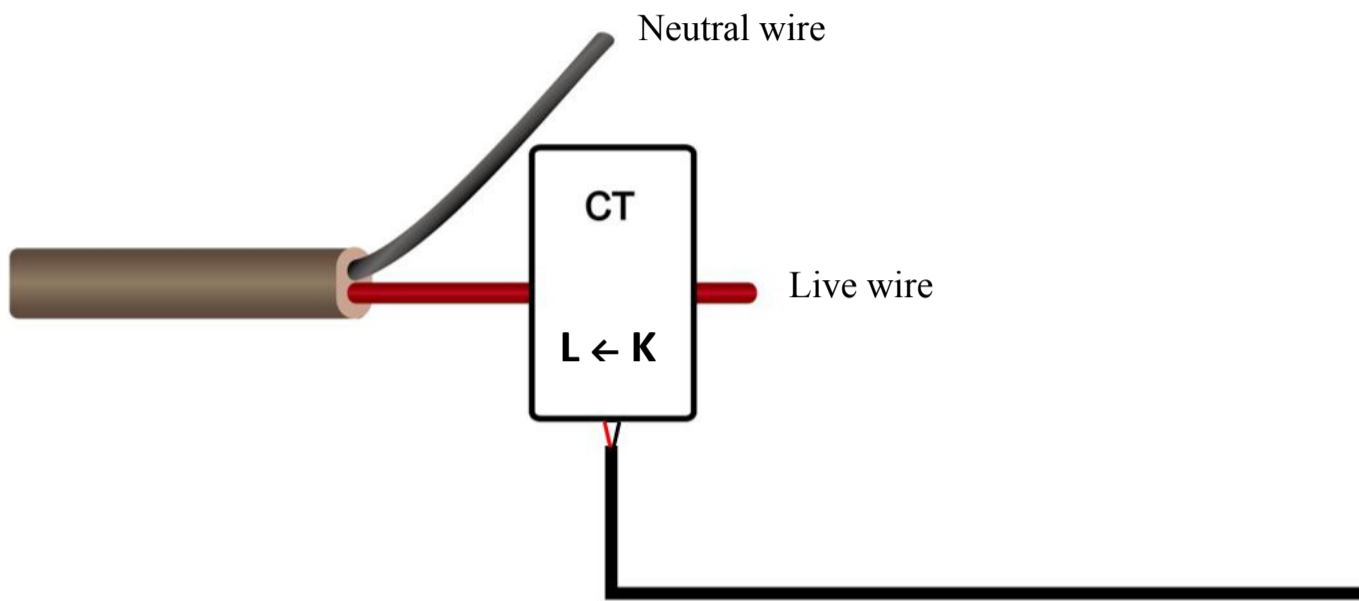

NTC thermistor

- 1 Put the probe on the surface of a motor or any electrical device.
- 2 Fix the probe with PTFE tape.



8. Battery Passivation

Many Netvox devices are powered by 3.6V ER14505 / ER18505 Li-SOCl₂ (lithium-thionyl chloride) batteries that offer many advantages including low self-discharge rate and high energy density. However, primary lithium batteries like Li-SOCl₂ batteries will form a passivation layer as a reaction between the lithium anode and thionyl chloride if they are in storage for a long time or if the storage temperature is too high. This lithium chloride layer prevents rapid self-discharge caused by continuous reactions between lithium and thionyl chloride, but battery passivation may also lead to voltage delay when the batteries are put into operation, and our devices may not work correctly in this situation.

As a result, please make sure to purchase batteries from reliable vendors, and it is suggested that if the storage period is more than one month from the date of battery production, all the batteries should be activated. If encountering the situation of battery passivation, please **activate the battery with 68Ω load resistance for 1 minute** to eliminate hysteresis in batteries.

9. Important Maintenance Instructions

Kindly pay attention to the following to achieve the best maintenance of the product:

- Keep the device dry. Rain, moisture, or any liquid might contain minerals and thus corrode electronic circuits. If the device gets wet, please dry it completely.
- Do not use or store the device in a dusty or dirty environment. It might damage its detachable parts and electronic components.
- Do not store the device under extremely hot conditions. High temperatures can shorten the life of electronic devices, destroy batteries, and deform or melt some plastic parts.
- Do not store the device in places that are too cold. Otherwise, when the temperature rises, moisture that forms inside the device will damage the board.
- Do not throw, knock, or shake the device. Rough handling of equipment can destroy internal circuit boards and delicate structures.
- Do not clean the device with strong chemicals, detergents, or strong detergents.
- Do not apply the device with paint. Smudges might block the device and affect the operation.
- Do not throw the battery into the fire, or the battery will explode. Damaged batteries may also explode.

All of the above applies to your device, battery, and accessories. If any device is not operating properly, please take it to the nearest authorized service facility for repair

10. FCC Statement:

This device complies with part 15 of the FCC Rules. Operation is subject to the following two conditions: (1) This device may not cause harmful interference, and (2) this device must accept any interference received, including interference that may cause undesired operation. This equipment has been tested and found to comply with the limits for a Class B digital device, pursuant to part 15 of the FCC Rules. These limits are designed to provide reasonable protection against harmful interference in a residential installation. This Equipment generates, uses and can radiate radio frequency energy and, if not installed and used in accordance with the instructions, may cause harmful interference to radio communications. However, there is no guarantee that interference will not occur in a Particular installation. If this equipment does cause harmful interference to radio or television reception, which can be determined by turning the equipment off and on, the user is encouraged to try to correct the interference by one or more of the following measures:

- Reorient or relocate the receiving antenna.
- Increase the separation between the equipment and receiver.
- Connect the equipment into an outlet on a circuit different from that to which the receiver is connected.
- Consult the dealer or an experienced radio/TV technician for help.

Caution: Any changes or modifications not expressly approved by the party responsible for compliance could void the user's authority to operate the equipment.

This equipment complies with FCC radiation exposure limits set forth for an uncontrolled environment. This transmitter must not be co-located or operating in conjunction with any other antenna or transmitter.