

KitchenAid®

CABINET DEPTH SIDE BY SIDE REFRIGERATOR

Use & Care Guide

For questions about features, operation/performance, parts accessories or service, call: 1-800-422-1230
In Canada, call for assistance 1-800-461-5681, for installation and service, call: 1-800-807-6777 or visit our website at...
www.kitchenaid.com or www.kitchenaid.com/canada

RÉFRIGÉRATEUR CÔTE À CÔTE À PROFONDEUR D'ARMOIRE

Guide d'utilisation et d'entretien

Au Canada, pour assistance, composer le 1-800-461-5681, pour installation ou service le 1-800-807-6777 ou visitez notre site web à...
www.kitchenaid.com/canada

Table of Contents/Table des matières 2

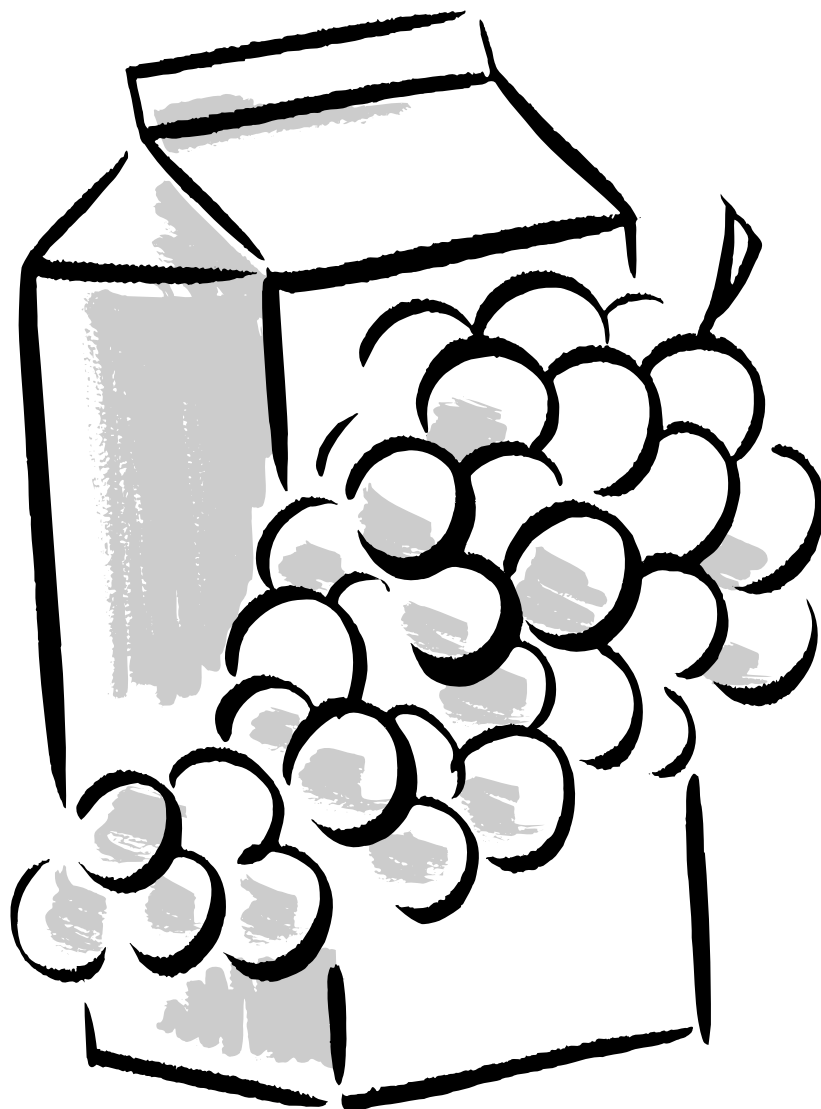

TABLE OF CONTENTS

REFRIGERATOR SAFETY	3
INSTALLING YOUR REFRIGERATOR	4
Unpacking Your Refrigerator	4
Space Requirements.....	4
Electrical Requirements	5
Water System Preparation.....	5
Connecting the Refrigerator to a Water Source.....	6
Custom Door Panels	7
Base Grille	8
Leveling Your Refrigerator	8
Understanding Sounds You May Hear.....	9
USING YOUR REFRIGERATOR	10
Ensuring Proper Air Circulation.....	10
Setting the Controls	10
Adjusting Control Settings	11
REFRIGERATOR FEATURES	11
Water and Ice Dispensers.....	11
Water Filtration and Monitoring System	13
Refrigerator Shelves.....	14
Meat Drawer, Crisper and Covers	14
Crisper Humidity Control	15
Beverage Drawer.....	15
Utility or Egg Bin.....	15
Wine or Can/Bottle Rack	15
FREEZER FEATURES	16
Ice Maker and Storage Bin	16
Freezer Shelf	16
Freezer Basket	17
DOOR FEATURES	17
Door Rails.....	17
Door Bins.....	17
CARING FOR YOUR REFRIGERATOR	17
Cleaning Your Refrigerator.....	17
Changing the Light Bulbs.....	18
Power Interruptions.....	19
Vacation and Moving Care.....	19
TROUBLESHOOTING	20
ASSISTANCE OR SERVICE	23
WARRANTY	24
WATER FILTER CERTIFICATIONS	25
PRODUCT DATA SHEETS	26

TABLE DES MATIÈRES

SÉCURITÉ DU RÉFRIGÉRATEUR	27
INSTALLATION DU RÉFRIGÉRATEUR	28
Déballage de votre réfrigérateur	28
Espacement requis.....	28
Spécifications électriques	29
Préparation du système d'eau	29
Raccordement du réfrigérateur à une canalisation d'eau	30
Panneaux de porte sur commande	31
Grille de la base.....	32
Nivellement du réfrigérateur.....	32
Les bruits de l'appareil que vous pouvez entendre.....	33
UTILISATION DU RÉFRIGÉRATEUR	34
Pour s'assurer d'une circulation d'air appropriée.....	34
Réglage des commandes	34
Ajustement du réglage des commandes.....	35
CARACTÉRISTIQUES DU RÉFRIGÉRATEUR	35
Distributeurs d'eau et de glaçons	35
Système de filtration et de contrôle d'eau.....	37
Tablettes du réfrigérateur.....	38
Tiroir à viande, bac à légumes et couvercles	39
Réglage de l'humidité dans les bacs à légumes	39
Tiroir à boisson.....	40
Bac utilitaire ou oeufrier	40
Porte-cannettes/bouteilles ou casier à vin	40
CARACTÉRISTIQUES DU CONGÉLATEUR	40
Machine à glaçons et bac d'entreposage	40
Clayette de congélateur	41
Panier du congélateur	42
CARACTÉRISTIQUES DE LA PORTE	42
Tringles dans la porte.....	42
Compartiments dans la porte	42
ENTRETIEN DE VOTRE RÉFRIGÉRATEUR	43
Nettoyage du réfrigérateur	43
Remplacement des ampoules d'éclairage	43
Pannes de courant	44
Entretien avant les vacances ou lors d'un déménagement.....	44
DÉPANNAGE	45
ASSISTANCE OU SERVICE	49
GARANTIE	50
FEUILLES DE DONNÉES SUR LE PRODUIT	51

REFRIGERATOR SAFETY

Your safety and the safety of others are very important.

We have provided many important safety messages in this manual and on your appliance. Always read and obey all safety messages.



This is the safety alert symbol.

This symbol alerts you to potential hazards that can kill or hurt you and others.

All safety messages will follow the safety alert symbol and either the word "DANGER" or "WARNING." These words mean:

! DANGER

You can be killed or seriously injured if you don't immediately follow instructions.

! WARNING

You can be killed or seriously injured if you don't follow instructions.

All safety messages will tell you what the potential hazard is, tell you how to reduce the chance of injury, and tell you what can happen if the instructions are not followed.

IMPORTANT SAFETY INSTRUCTIONS

WARNING: To reduce the risk of fire, electric shock, or injury when using your refrigerator, follow these basic precautions:

- Plug into a grounded 3 prong outlet.
- Do not remove ground prong.
- Do not use an adapter.
- Do not use an extension cord.
- Disconnect power before servicing.
- Replace all panels before operating.
- Remove doors from your old refrigerator.
- Use nonflammable cleaner.
- Keep flammable materials and vapors, such as gasoline, away from refrigerator.
- Use two or more people to move and install refrigerator.
- Disconnect power before installing ice maker (on ice maker kit ready models only).
- Use a sturdy glass when dispensing ice or water (on some models).

SAVE THESE INSTRUCTIONS

Proper Disposal of Your Old Refrigerator

! WARNING

Suffocation Hazard

Remove doors from your old refrigerator.

Failure to do so can result in death or brain damage.

Before you throw away your old refrigerator or freezer:

- Take off the doors.
- Leave the shelves in place so that children may not easily climb inside.

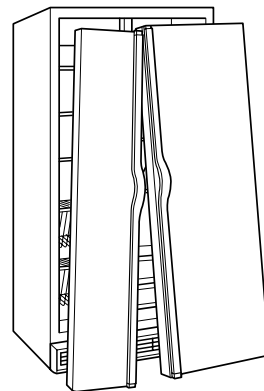

IMPORTANT: Child entrapment and suffocation are not problems of the past. Junked or abandoned refrigerators are still dangerous – even if they will sit for "just a few days." If you are getting rid of your old refrigerator, please follow these instructions to help prevent accidents.

INSTALLING YOUR REFRIGERATOR

Unpacking Your Refrigerator

⚠️ WARNING

Excessive Weight Hazard

Use two or more people to move and install refrigerator.

Failure to do so can result in back or other injury.

Removing packaging materials

- Remove tape and any labels from your refrigerator before using (except the model and serial number label).
To remove any remaining tape or glue, rub the area briskly with your thumb. Tape or glue residue can also be easily removed by rubbing a small amount of liquid dish soap over the adhesive with your fingers. Wipe with warm water and dry.
- Do not use sharp instruments, rubbing alcohol, flammable fluids, or abrasive cleaners to remove tape or glue. These products can damage the surface of your refrigerator. For more information, see the "Refrigerator Safety" section.

IMPORTANT: Do not remove any permanent instruction labels inside your refrigerator, or the Tech Sheet that is fastened to the base grille.

When Moving Your Refrigerator:

Your refrigerator is heavy. When moving the refrigerator for cleaning or service, be sure to protect the floor. Always pull the refrigerator straight out when moving it. Do not wiggle or "walk" the refrigerator when trying to move it, as floor damage could occur.

Cleaning before use

After you remove all of the packaging materials, clean the inside of your refrigerator before using it. See the cleaning instructions in the "Caring for Your Refrigerator" section.

Important information to know about glass shelves and covers:

Do not clean glass shelves or covers with warm water when they are cold. Shelves and covers may break if exposed to sudden temperature changes or impact, such as bumping. For your protection, tempered glass is designed to shatter into many small, pebble-size pieces. This is normal. Glass shelves and covers are heavy. Use special care when removing them to avoid impact from dropping.

Space Requirements

⚠️ WARNING



Explosion Hazard

Keep flammable materials and vapors, such as gasoline, away from refrigerator.

Failure to do so can result in death, explosion, or fire.

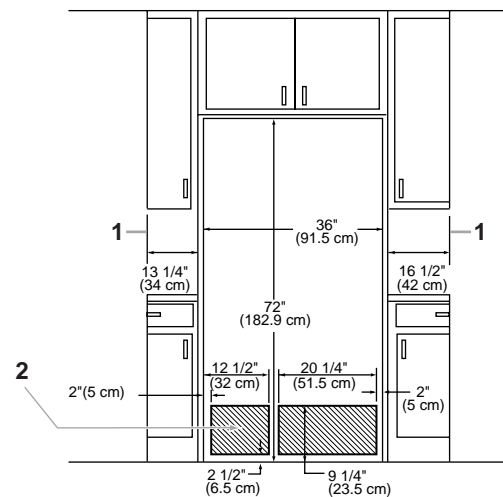

1. Minimum fixed wall position
2. Recommended locations for electrical and water connections.
3. For full-overlay cabinet doors and a trim kit, the height of the opening must be 72 $\frac{3}{4}$ in. (184.8 cm).

- If you are installing the refrigerator to fit flush with the front of the base cabinets, all shoe molding and baseboards must be removed from the rear of the refrigerator opening.
- The water hookup and electrical hookup must be placed near the bottom of the refrigerator.
- A trim kit is available for those installations where the refrigerator will not fit flush. See the "Assistance or Service" section for ordering information.

NOTE: Do not install the refrigerator near an oven, radiator, or other heat source, nor in a location where the temperature will fall below 55°F (13°C).

Electrical Requirements

⚠️ WARNING



Electrical Shock Hazard

Plug into a grounded 3 prong outlet.

Do not remove ground prong.

Do not use an adapter.

Do not use an extension cord.

Failure to follow these instructions can result in death, fire, or electrical shock.

Before you move your refrigerator into its final location, it is important to make sure you have the proper electrical connection:

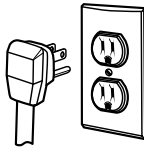

Recommended grounding method

A 115 Volt, 60 Hz., AC only 15 or 20 ampere fused, grounded electrical supply is required. It is recommended that a separate circuit serving only your refrigerator be provided. Use an outlet that cannot be turned off by a switch. Do not use an extension cord.

NOTE: Before performing any type of installation, cleaning, or removing a light bulb, turn the control, (Thermostat, Refrigerator or Freezer Control depending on the model) to OFF and then disconnect the refrigerator from the electrical source. When you are finished, reconnect the refrigerator to the electrical source and reset the control (Thermostat, Refrigerator or Freezer Control depending on the model) to the desired setting.

Water System Preparation

Please read before using the water system.

Immediately after installation, follow the steps below to make sure that the water system is properly cleaned.

1. Turn off the ice maker by opening the freezer door and lifting up the wire shut-off arm as shown.

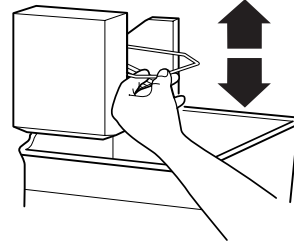

2. Flush the water system by dispensing and discarding 2 to 3 gallons (approximately 6 to 7 minutes) of water through the dispenser. This will clean the system and help clear air from the lines. Additional flushing may be required in some households.
3. Turn on the ice maker by opening the freezer door and lowering the wire shut-off arm as shown. Allow 24 hours to produce the first batch of ice. Discard the first three batches of ice produced. Ice maker should then produce approximately 7 to 9 batches of ice in a 24-hour period.

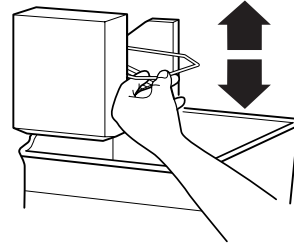

Connecting the Refrigerator to a Water Source

Read all directions carefully before you begin.

IMPORTANT:

In order to prevent possible leakage resulting in property damage, be sure to observe the following:

- If operating the refrigerator before installing the water connection, turn ice maker to the OFF position to prevent operation without water.
- All installations must be in accordance with local plumbing code requirements.
- Use the water tubing provided and check for leaks.
- Install water tubing only in areas where temperatures will remain above freezing.

REMEMBER: It may take up to 24 hours for your ice maker to begin producing ice.

Tools required:

- Standard screwdriver
- $\frac{7}{16}$ in. and $\frac{1}{2}$ in. open-end wrenches or two adjustable wrenches
- $\frac{1}{4}$ in. drill bit
- Hand drill or electric drill (properly grounded)

NOTE: Your refrigerator dealer has a kit available with a $\frac{1}{4}$ in. saddle-type shut-off valve, a union, and copper tubing. Before purchasing, make sure a saddle-type valve complies with your local plumbing codes. Do not use a piercing-type or $\frac{3}{16}$ in. (4.76 mm) saddle valve which reduces water flow and clogs more easily.

Cold Water Supply

The ice maker water valve contains a flow washer which is used as a water pressure regulator. The ice maker needs to be connected to a cold water line with water pressure between 30 and 120 psi. If a problem occurs, call your utility company.

Connecting to water line:

1. Unplug refrigerator or disconnect power.
2. Turn OFF main water supply. Turn ON nearest faucet long enough to clear line of water.
3. Find a $\frac{1}{2}$ in. (12.70 mm) to $1\frac{1}{4}$ in. (3.18 cm) vertical COLD water pipe near the refrigerator.

NOTE: Horizontal pipe will work, but the following procedure must be followed: Drill on the top side of the pipe, not the bottom. This will help keep water away from the drill. This also keeps normal sediment from collecting in the valve.

4. Route $\frac{1}{4}$ in. (6.35 mm) copper tubing from the water pipe to the lower rear corner of the refrigerator location. Be sure both ends of copper tubing are cut square.
5. Turn OFF main water supply. Turn ON nearest faucet long enough to clear the line of water.
6. Using a grounded drill, drill a $\frac{1}{4}$ in. (6.35 mm) hole in the cold water pipe you have selected.

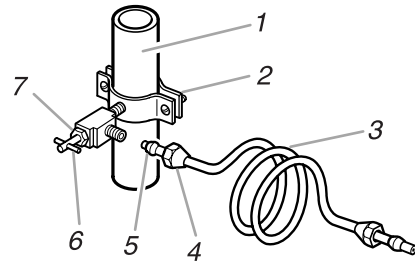

1. Cold Water Pipe
2. Pipe Clamp
3. Copper Tubing
4. Compression Nut
5. Compression Sleeve
6. Shut-Off Valve
7. Packing Nut

7. Fasten shut-off valve to cold water pipe with pipe clamp. Be sure outlet end is solidly in the $\frac{1}{4}$ in. (6.35 mm) drilled hole in the water pipe and that washer is under the pipe clamp. Tighten packing nut. Tighten the pipe clamp screws carefully and evenly so washer makes a watertight seal. Do not overtighten or you may crush the copper tubing, especially if soft (coiled) copper tubing is used. Now you are ready to connect the copper tubing.
8. Slip compression sleeve and compression nut on copper tubing as shown in the diagram. Insert the end of the tubing into the outlet end of the shutoff valve as far as it will go. Screw the compression nut onto the outlet end with an adjustable wrench. Do not overtighten.
9. Place the free end of the tubing into a container or sink, and turn ON main water supply and flush out tubing until water is clear. Turn OFF the shut-off valve on the water pipe.
10. Slip the compression sleeve and compression nut onto the other end of the copper tube. Insert into the tube coupling as far as it will go. Screw compression nut onto coupling and tighten with wrenches. Do not overtighten.
11. Add strain relief to hold coupling in position.

Connecting to refrigerator:

1. Remove the shipping tape from gray, coiled water tubing on the rear of the refrigerator.
2. **Style 1:** Thread the provided nut onto the coupling on the end of the copper tubing. Tighten the nut by hand. Then tighten it with a wrench two more turns. Do not overtighten.

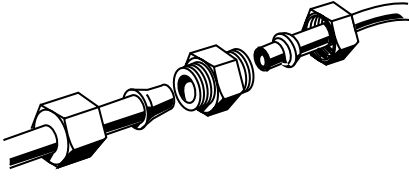

Style 2: Thread the provided nut onto the water valve as shown.

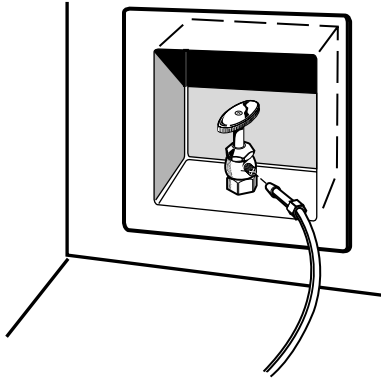

Tighten the nut by hand. Then tighten it with a wrench two more turns. Do not overtighten.

3. **Turn shut-off valve ON. Check for leaks.** Tighten any nuts or connections (including connections at the valve) that leak.
4. Plug in refrigerator or reconnect power.
5. Flush the water system (see the "Water System Preparation" section).

NOTE: It may take up to 24 hours for your ice maker to begin producing ice.

Custom Door Panels

Creating Custom Wood Panels

If you plan to install custom wood decorator panels, you will need to create the panels yourself or consult your cabinet maker or carpenter. See dimensional drawings for wood panel inserts.

Flat panels:

You can create a custom flat panel a maximum of $\frac{1}{4}$ in. (6.35 mm) thick to replace your decorator panels. Flat wood panels less than $\frac{1}{4}$ in. (6.35 mm) thick are not recommended.

Raised panels:

A raised panel design can be created by screwing or gluing wood panels to $\frac{1}{4}$ in. (6.35 mm) backing or by using $\frac{3}{4}$ in. (19.05 mm) stock with routed edges. Raised panels should be spaced $2\frac{1}{4}$ in. (5.70 cm) from the back edge of the handle to allow room for fingers to grasp the handle.

Weight requirements for raised panel inserts:

- Refrigerator door panel should not exceed 28 lbs. (12.7 kg).
- Freezer door panels should not exceed 21 lbs. (9.5 kg) combined weight.

Dimensions for custom wood panels:

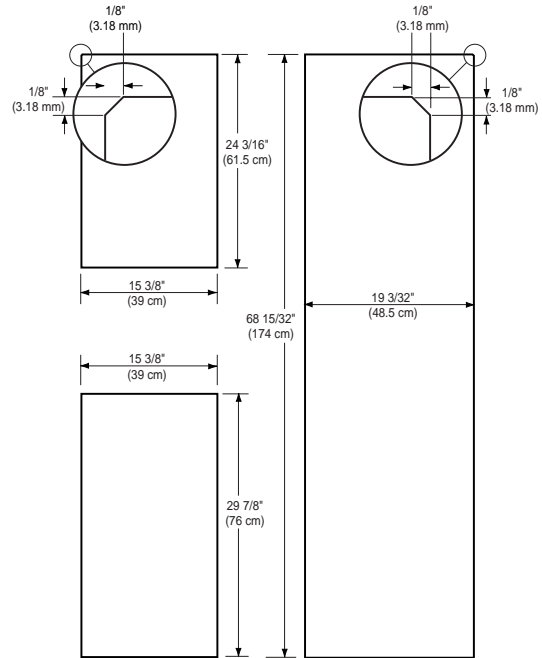

Installing Custom Wood Panels

1. Remove any packing tape.
2. Remove the refrigerator and freezer door trims from the hinge side of each door by pulling the trim away from the bottom of the door first.
3. Partially unscrew the two screws that hold the top trim in place. It is not necessary to completely remove the screws. Loosen the screws approximately $\frac{1}{4}$ in. (6.35 mm) from the trim to allow the panels to slide freely.
4. Remove the existing door panels, if panels were provided.
5. Slide custom door panels into place.

NOTE: The freezer door panels may require $\frac{1}{8}$ in. (3.18 mm) cardboard fillers behind the panels to keep them from being loose in that area.

- Replace the hinge side trims by inserting the notched end under the top trim first.
- Tighten the two top trim screws.

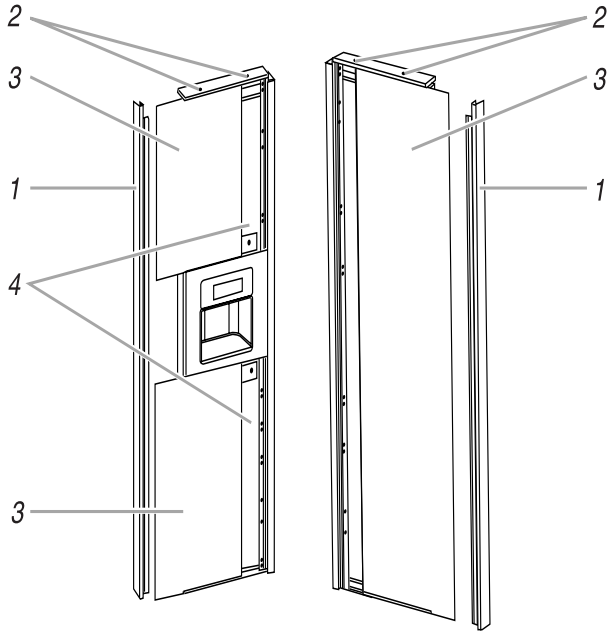

- Side Trims
- Top Trim Screws
- Door Panels
- Filler Panels

Base Grille

Style 1:

To remove the base grille:

- Open the refrigerator and freezer doors 90°.
- Remove screws from the base grille using a Phillips screwdriver.

Note: Do Not Remove Tech Sheet that is fastened behind the base grille.

To replace the base grille:

- Open the refrigerator and freezer doors to 90°.
- Position the base grille in front of the refrigerator and replace the screws.

Style 2:

To remove the base grille:

- Open the refrigerator and freezer doors to 90°.
- Grasp the grille with both hands.
- Lift up and tilt the top of the grille toward you.

NOTE: Do not remove the Tech Sheet that is fastened behind the grille.

To replace the base grille:

- Open the refrigerator and freezer doors to 90°.
- Place the lower clips in the openings in the metal panel.
- Roll the grille up toward the refrigerator until it snaps into place.

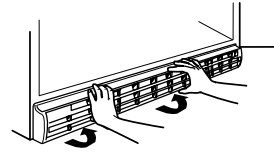

Leveling Your Refrigerator

Your refrigerator has a front and rear roller at the base of the product on each side. All four rollers can be adjusted from the front of the product. If your refrigerator seems unsteady or you want the doors to close easier, adjust the refrigerator's tilt using the instructions below:

- Check the installation location to be sure that you have the proper clearance for the refrigerator. (See the "Space Requirements" section.)
- Plug into a grounded 3 prong outlet.
- Move the refrigerator into its final position.
- Open the refrigerator and freezer doors to locate the leveling bolts at the left and right of the refrigerator base. If your refrigerator has a base grille, remove it (see "Base Grille" earlier in this section).

NOTE: The top bolt will adjust the rear of the refrigerator, and the bottom bolt will adjust the front of the refrigerator.

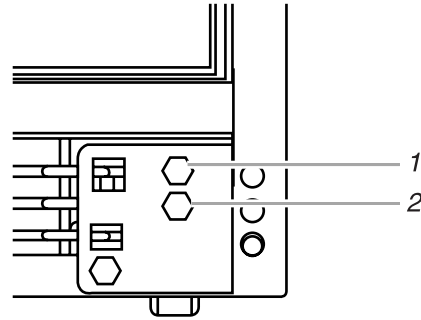

- Rear Leveling Bolt
- Front Leveling Bolt

- Use a ½ in. (12.70 mm) socket wrench to adjust the leveling bolts. Turn the leveling bolt to the right to raise that side of the refrigerator or turn the leveling bolt to the left to lower that side. It may take several turns of the leveling bolts to adjust the tilt of the refrigerator.

NOTE: Be careful not to unscrew the leveling bolts too much when lowering the refrigerator. The bolt head will start to come away from the refrigerator when in the lowest position. If the screw does come out of the rear roller bracket, the compartment access cover on the back of the refrigerator will have to be removed to reinstall the bolt.

- Adjust the front leveling bolt to bring the refrigerator top parallel with the cabinet above the refrigerator. Leave approximately $\frac{1}{8}$ in. (3.18 mm) gap between the top hinges and the cabinet. If you do not have a cabinet above the refrigerator, simply adjust the refrigerator to make it level.

Style 1

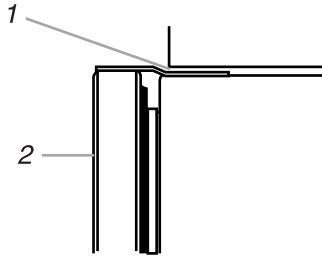

- Leave $\frac{1}{8}$ in. (3.18 mm) minimum clearance for leveling the refrigerator. Leave $\frac{1}{4}$ in. (6.35 mm) minimum clearance if you have full-overlay cabinet doors.
- Front of the refrigerator

Style 2

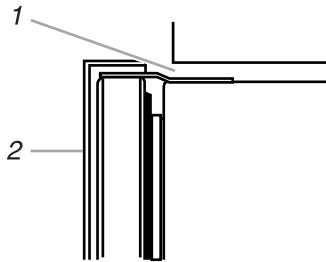

- Leave $\frac{3}{4}$ in. (19.05 mm) minimum clearance between a full-overlay cabinet door and a refrigerator with a trim kit.
- Front of the refrigerator

- Adjust the rear leveling bolt to bring the refrigerator level with the side cabinets or cabinet end panels.
- If you want, you may now use the four leveling bolts to raise the refrigerator to close the gap between the refrigerator top hinge and the cabinet opening. Check that all four rollers still touch the floor and that the cabinet doors above the refrigerator open all the way.

NOTE: Cabinets with full-overlay doors will require $\frac{1}{4}$ in. (6.35 mm) additional clearance between the top hinge and cabinet to prevent the doors from hitting the hinge when opening. If you have a trim panel kit on the refrigerator doors, $\frac{3}{4}$ in. (19.05 mm) additional clearance is needed to prevent the cabinet doors from hitting the refrigerator door trim.

- Replace the base grille.

Understanding Sounds You May Hear

Your new refrigerator may make sounds that your old one didn't make. Because the sounds are new to you, you might be concerned about them. Most of the new sounds are normal. Hard surfaces, like the floor, walls, and cabinets, can make the sounds seem louder than they actually are. The following describes the kinds of sounds and what may be making them.

- If your product is equipped with an ice maker, you will hear a buzzing sound when the water valve opens to fill the ice maker for each cycle.
- The defrost timer will click when the automatic defrost cycle begins and ends. Also, the Thermostat Control (or Refrigerator Control depending on the model) will click when cycling on and off.
- Rattling noises may come from the flow of refrigerant, the water line, or items stored on top of the refrigerator.
- Your refrigerator is designed to run more efficiently to keep your food items at the desired temperature. The high efficiency compressor may cause your new refrigerator to run longer than your old one, and you may hear a pulsating or high-pitched sound.
- Water dripping on the defrost heater during a defrost cycle may cause a sizzling sound.
- You may hear the evaporator fan motor circulating the air through the refrigerator and freezer compartments.
- As each cycle ends, you may hear a gurgling sound due to the refrigerant flowing in your refrigerator.
- Contraction and expansion of the inside walls may cause a popping noise.
- You may hear air being forced over the condenser by the condenser fan.
- You may hear water running into the drain pan during the defrost cycle.

USING YOUR REFRIGERATOR

Ensuring Proper Air Circulation

In order to ensure proper temperatures, you need to permit airflow between the two sections. Cold air enters the bottom of the freezer section and moves up. It then enters the refrigerator section through the top vent. Air then returns to the freezer as shown.

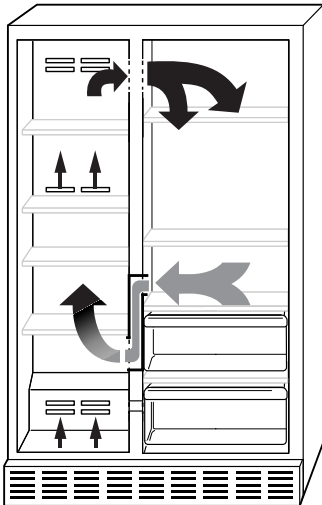

Do not block any of these vents with food such as soda, cereal, bread, etc. If the vents are blocked, airflow will be prevented and the temperature controls will not function properly.

IMPORTANT: Because air circulates between both sections, any odors formed in one section will transfer to the other. You must thoroughly clean both sections to eliminate odors. To prevent odor transfer from food, wrap or cover foods tightly.

Checking Airflow

To measure the amount of cold air being directed from the freezer compartment into the refrigerator section, hold your hand in front of the top vent. You can adjust the control to feel the different amounts of airflow.

For further information on temperatures inside your refrigerator, refer to the "Troubleshooting" section.

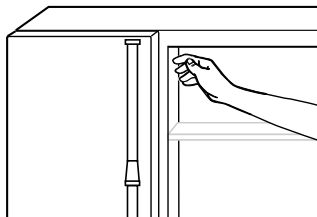

Setting the Controls

Give your refrigerator time to cool down completely before adding food. It is best to wait 24 hours before you put food into the refrigerator.

IMPORTANT: If you add food before the refrigerator has cooled completely, your food may spoil. Turning the Refrigerator and Freezer Controls to a cooler than recommended setting will not cool the compartments any faster.

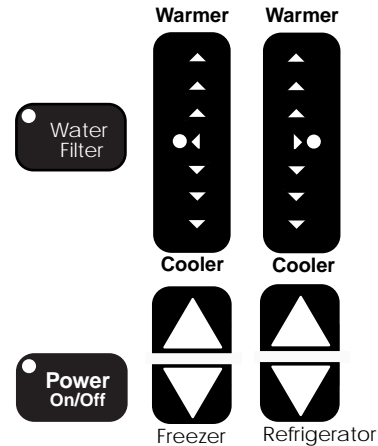

The Refrigerator Control adjusts the refrigerator compartment temperature. Press the up arrow to make the temperature warmer. Press the down arrow to make the temperature colder.

The Freezer Control adjusts the freezer compartment temperature. Press the up arrow to make the temperature warmer. Press the down arrow to make the temperature colder.

The Power Control turns off the refrigerator's temperature control. Press the Power Control button.

NOTE: Your product will **not** cool when the Power Control is set to OFF.

The Automatic Exterior Moisture control continuously guards against moisture buildup on the outside of your refrigerator cabinet. This control does not have to be set or adjusted.

Adjusting Control Settings

Give the refrigerator time to cool down completely before adding food. It is best to wait 24 hours before you put food into the refrigerator. The controls are set correctly when milk or juice is as cold as you like and when ice cream is firm.

If you need to adjust temperatures in the refrigerator or freezer, use the settings listed in the chart below as a guide. Wait at least 24 hours between adjustments.

CONDITION/REASON:	RECOMMENDED ADJUSTMENT:
REFRIGERATOR section too warm <ul style="list-style-type: none"> ■ Door opened often ■ Large amount of food added ■ Room temperature very warm 	Press the REFRIGERATOR Control arrow down to the next lower number
FREEZER section too warm/ice not made fast enough <ul style="list-style-type: none"> ■ Door opened often ■ Large amount of food added ■ Very cold room temperature (can't cycle often enough) ■ Heavy ice usage ■ Air diffuser blocked by items 	Press the FREEZER Control arrow down to the next lower number Move packages out of airstream
REFRIGERATOR section too cold <ul style="list-style-type: none"> ■ Controls not set correctly for your conditions 	Press the REFRIGERATOR Control arrow up to the next higher number
FREEZER section too cold <ul style="list-style-type: none"> ■ Controls not set correctly for your conditions 	Turn FREEZER Control arrow up to the next higher number

REFRIGERATOR FEATURES

Your model may have some or all of these features. Features that can be purchased separately as product accessories are labeled with the word "Accessory." Not all accessories will fit all models. If you are interested in purchasing one of the accessories please call the toll-free number on the cover or in the "Assistance or Service" section.

Important information to know about glass shelves and covers:

Do not clean glass shelves or covers with warm water when they are cold. Shelves and covers may break if exposed to sudden temperature changes or impact, such as bumping. For your protection, tempered glass is designed to shatter into many small, pebble-size pieces. This is normal. Glass shelves and covers are heavy. Use special care when removing them to avoid impact from dropping.

Water and Ice Dispensers (on some models)

! WARNING



Cut Hazard

Use a sturdy glass when dispensing ice or water. Failure to do so can result in cuts.

Depending on your model, you may have one or more of the following options: the ability to select either crushed or cubed ice, a special light that turns on when you use the dispenser, or a lock option to avoid accidental dispensing.

The ice dispenser

Ice dispenses from the ice maker storage bin in the freezer. When the dispenser lever is pressed:

- A trap door opens in a chute between the dispenser and the ice bin.
- Ice moves from the bin and falls through the chute.
- When you release the dispenser lever, the trap door closes and the ice dispensing stops. The dispensing system will not operate when the freezer door is open.

Some models dispense both cubed and crushed ice. Before dispensing ice, select which type of ice you prefer. The button controls are designed for easy use and cleaning.

- For cubed ice, press the CUBE button until the red indicator appears in the window above the CUBE button.

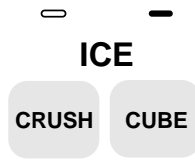

- For crushed ice, press the CRUSH button until the red indicator appears in the window above the CRUSH button.

For crushed ice, cubes are crushed before being dispensed. This may cause a slight delay when dispensing crushed ice. Noise from the ice crusher is normal, and pieces of ice may vary in size. When changing from CRUSH to CUBE, a few ounces of crushed ice will be dispensed along with the first cubes.

To dispense ice:

1. Press button for the desired type of ice.
2. Press a **sturdy** glass against the ice dispenser lever. Hold the glass close to the dispenser opening so ice does not fall outside of the glass.

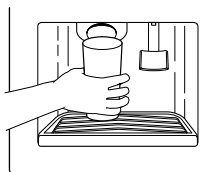

IMPORTANT: You do not need to apply a lot of pressure to the lever in order to activate the ice dispenser. Pressing hard will not make the ice dispense faster or in greater quantities.

3. Remove the glass to stop dispensing.

NOTE: The first few batches of ice may have an off-flavor from new plumbing and parts. Throw the ice away. Also, take large amounts of ice from the ice bin, not through the dispenser.

The water dispenser

When the refrigerator is first hooked up, press the water dispenser bar with a glass or jar until you draw and discard 2 to 3 quarts (1.9 to 2.8 L). It will take three to four minutes for the water to begin dispensing. The water you draw and discard rinses the pipes.

Allow several hours for the refrigerator to cool down and chill water.

IMPORTANT: Depending on your model, the small removable tray at the bottom of the dispenser is designed to catch small spills and allow for easy cleaning. There is no drain in the tray. The tray can be removed from the dispenser and carried to the sink to be emptied or cleaned.

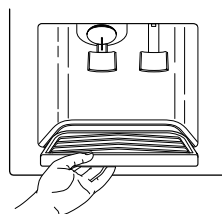

To dispense water:

1. Press a glass against the water dispenser lever.
2. Remove the glass to stop dispensing.

NOTE: Dispense enough water every week to maintain a fresh supply.

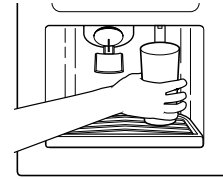

The dispenser light

The dispenser area has a light. It can be turned on manually by pressing the ON button at the right hand side of the control panel. The red indicator above the ON button will appear. **On some models:** Whenever you use the dispenser the lever will automatically turn the light on.

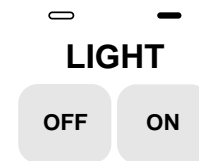

NOTE: See the “Changing the Light Bulbs” section for information on changing the dispenser light bulb.

On models without crushed ice, the light switch is a rocker-style type. Push the switch to turn the light on, and push again to turn the light off.

The dispenser lock (on some models)

Your dispenser can be turned off for easy cleaning or to prevent accidental dispensing by small children and pets. To turn off the dispenser, press the LOCK button. The indicator will appear above the LOCK button and the ice and water dispensers will not work. To unlock the dispenser, press the UNLOCK button until the indicator appears. Then continue to dispense ice or water as usual.

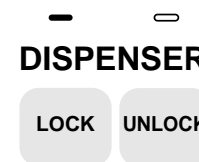

NOTE: The lock feature does not shut off power to the product, to the ice maker, or to the dispenser light. It simply deactivates the dispenser levers.



Water Filtration and Monitoring System

(on some models)

The water filter indicator light

The water filter indicator light will help you know when to change your water filter cartridge. The light is located at the top of the refrigerator compartment. The light will change from green to yellow. This tells you that it is almost time to change the water filter cartridge (90% of the filter life has been used). It is recommended that you replace the water filter cartridge when the water filter indicator light changes to red OR water flow to your water dispenser or ice maker decreases noticeably. (See "Changing a water filter cartridge" later in this section.)

NOTE: Do not use with water that is microbiologically unsafe or of unknown quality without adequate disinfection before or after the system.

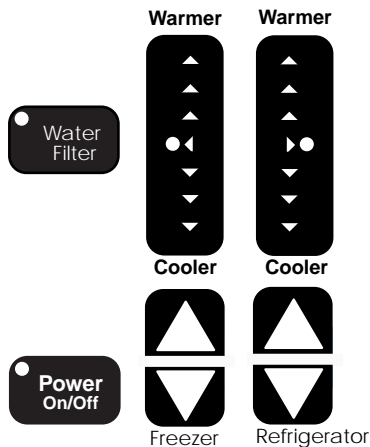

After changing the water filter cartridge, reset the water filter indicator light by pressing the WATER FILTER button 5 times. The indicator light will change from red to green when the system is reset.

Changing a water filter cartridge

The water filter is located below the freezer compartment door.

1. Locate the water filter cartridge cap in the front base grille below the freezer compartment door. Rotate the cap counterclockwise to a vertical position and pull the cap and filter cartridge out through the base grille.

NOTE: There will be water in the cartridge. Some spilling may occur.

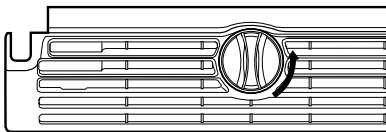

2. Remove the cartridge cap by sliding it off the end of the old cartridge. The cap will slide to the left or right. **DO NOT DISCARD THE CAP.**

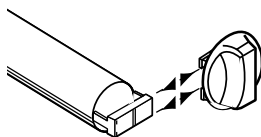

3. Take the new cartridge out of its packaging and remove protective cover from o-rings.

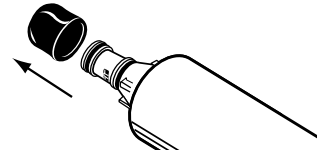

4. Slide the cartridge cap onto the new cartridge as shown in Step 2.
5. With cartridge cap in the vertical position, push the new filter cartridge into the base grille until it stops. Rotate the cartridge cap clockwise to a horizontal position.

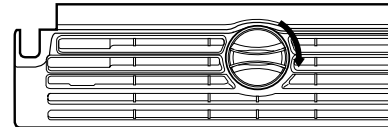

6. RUN WATER THROUGH THE DISPENSER UNTIL THE WATER RUNS CLEAR (about 2-3 gallons or 6-7 minutes). This will clean the system and clear air from the lines. Additional flushing may be required in some households.

NOTE: As air is cleared from the system, water may spurt out of the dispenser.

Using the dispenser without the water filter

You can run the dispenser without a water filter cartridge. Your water will not be filtered. If you run the dispenser without a water filter cartridge, keep the cartridge cap and replace it in the base grille for future use.

1. Remove the water filter cartridge (See "Changing a water filter cartridge" earlier in this section.) Then slide the cartridge cap off the end of the filter cartridge. **DO NOT DISCARD THE CAP.**
2. With the cartridge cap in the vertical position, insert the cap into the base grille until it stops.

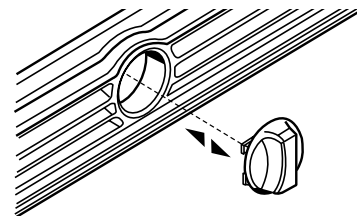

3. Rotate the cartridge cap to a horizontal position as shown in Step 5. (See "Changing a water filter cartridge" earlier in this section.)

NOTE: The cartridge cap may not be even with the base grille.

Ordering replacement filters

To order more water filter cartridges, see the "Assistance or Service" section.

Refrigerator Shelves

The shelves in your refrigerator are adjustable to meet your individual storage needs. Your model may have glass or wire shelves.

Storing similar food items together in your refrigerator and adjusting the shelves to fit different heights of items will make finding the exact item you want easier. It will also reduce the amount of time the refrigerator door is open, and save energy.

Slide-out Shelves (on some models)

- To slide out shelf, carefully pull front of shelf toward you.
- To slide in shelf, push shelf in until it stops.

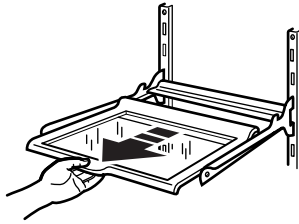

To remove and replace a shelf in a metal frame:

1. Pull the shelf forward to the stop.
2. Tilt front of the shelf up and lift it slightly as you pull the shelf from the frame.
3. Replace the shelf by guiding it back into the slots on the frame and pushing the shelf in past the stop.

Shelves and Shelf Frames

To remove and replace a shelf/frame:

1. Remove the shelf/frame by tilting it up at the front and lifting it out of the shelf supports.
2. Replace the shelf/frame by guiding the rear shelf hooks into the shelf supports. Tilt the front of the shelf up until the rear shelf hooks drop into the shelf supports.
3. Lower the front of the shelf and check to make sure that the shelf is securely in position.

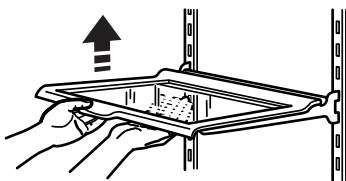

Fixed Shelves (on some models)

To remove and replace the shelf in a fixed metal frame:

1. Remove the shelf by pushing up on the front of the shelf until it snaps free.
2. Slide the shelf forward and lift up.
3. Replace the shelf by positioning the sides of the shelf over the frame.
4. Slide the shelf back until the rear hooks are securely in place. Snap the front of the shelf to the frame.

Meat Drawer, Crisper and Covers

To remove and replace the meat drawer and crisper:

1. Slide the meat drawer or crisper straight out to the stop. Lift the front of the drawer with one hand while supporting the bottom of the drawer with your other hand and slide the drawer out the rest of the way.
2. Replace the meat drawer or crisper by sliding it back in fully past the drawer stop.

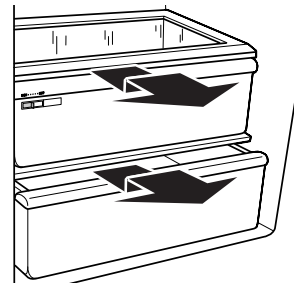

To remove and replace the meat drawer or crisper covers:

1. Remove the meat drawer or crisper. Press up in center of crisper glass insert until it rises above the plastic frame. Holding the crisper glass firmly, carefully slide the glass insert forward to remove.
2. Lift crisper cover frame up and remove. Repeat steps to remove the meat drawer cover.

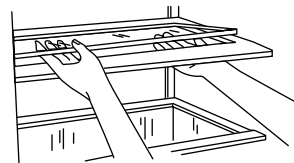

Meat storage guide

Store most meat in original wrapping as long as it is airtight and moisture-proof. Rewrap if necessary. See the following chart for storage times. When storing meat longer than the times given, freeze the meat.

Fresh fish or shellfish use same day as purchased

Chicken, ground beef, variety meat (liver, etc.) 1-2 days

Cold cuts, steaks/roasts 3-5 days

Cured meats 7-10 days

Leftovers - Cover leftovers with plastic wrap, aluminum foil, or plastic containers with tight lids.

Crisper Humidity Control

(on some models)

You can control the amount of humidity in the moisture-sealed crisper. Adjust the control to any setting between LOW and HIGH.

- **LOW (open)** lets moist air out of the crisper for best storage of fruits and vegetables with skins.

Fruit: Wash, let dry and store in refrigerator in plastic bag or crisper. Do not wash or hull berries until they are ready to use. Sort and keep berries in original container in crisper, or store in a loosely closed paper bag on a refrigerator shelf.

Vegetables with skins: Place in plastic bags or plastic container and store in crisper.

- **HIGH (closed)** keeps moist air in the crisper for best storage of fresh, leafy vegetables.

Leafy vegetables: Wash in cold water, drain and trim or tear off bruised and discolored areas. Place in plastic bag or plastic container and store in crisper.

Humidity control location:

- Humidity Control on crisper drawer (Style 1 - on left)
- Humidity Control on crisper cover (Style 2 - on right).

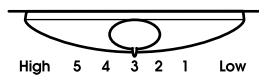
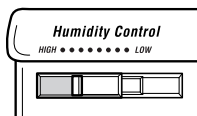

Beverage Drawer

To remove and replace the beverage drawer:

1. Remove the beverage drawer by sliding it straight out to the stop. Lift up at the front and slide the beverage drawer out the rest of the way.
2. Replace the beverage drawer by sliding it back in fully past the stop.

To remove and replace the beverage drawer shield:

1. Remove the beverage drawer shield by grasping it at the bottom center. Pull up in the center while turning the shield slightly to one side.
2. Replace the shield by grasping it at the bottom center and inserting one side into the beverage drawer cover.
3. Carefully bend the shield at the center to insert the other side into the cover.

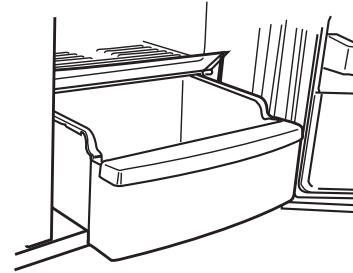

Utility or Egg Bin

(on some models - Accessory)

Depending on your model, you may have a one piece utility bin or a three piece egg bin. To use the three piece egg bin, remove the cover and place the eggs in the egg tray. Replace cover and store on an interior refrigerator shelf. If you prefer, you can remove the egg tray and place the entire carton of eggs in the bin. Replace the cover.

NOTE: Eggs should be stored in a covered container. If your model does not have an egg bin or covered utility bin, store eggs in their original container on an interior shelf.

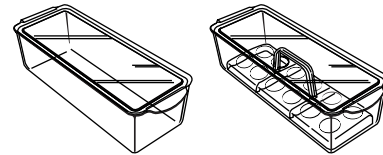

Wine or Can/Bottle Rack

(on some models - Accessory)

To remove and replace the wine rack (left) or can/bottle rack (right):

1. Remove the rack by pulling it straight out from the shelf.
2. Replace the rack by sliding it in between the shelf and the wall of the refrigerator.

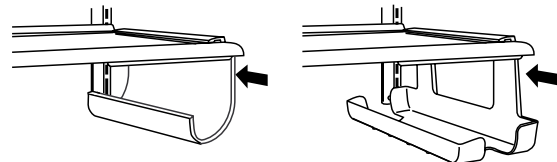

FREEZER FEATURES

Your model may have some or all of these features. Features that can be purchased separately as product accessories are labeled with the word "Accessory." Not all accessories will fit all models. If you are interested in purchasing one of the accessories, please call the toll-free number on the cover or in the "Assistance or Service" section

Ice Maker and Storage Bin (on some models - Accessory)

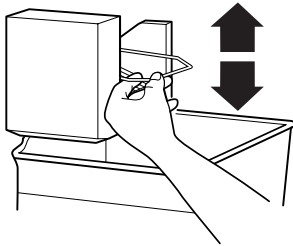

To turn the ice maker on:

The on/off switch for the ice maker is a wire shut-off arm located on the side of the ice maker. To turn the ice maker on, simply lower the wire shut-off arm.

NOTE: The ice maker will not make ice until the freezer is cold enough. Allow 24 hours to produce the first batch of ice. Discard the first three batches of ice produced.

To turn the ice maker off:

- Automatic turn off: As ice is made, the ice cubes will fill the ice storage bin. The ice cubes will raise the wire shut-off arm to the OFF (arm up) position.
- Manual turn off: Lift the wire shut-off arm to the OFF (arm up) position and listen for the click to make sure the ice maker will not continue to operate.

To remove and replace the ice bin:

1. Pull the covering panel out from the bottom and then slide it back toward the rear.
2. Lift the wire shut-off arm so it clicks into the OFF (arm up) position. Ice can still be dispensed, but no more can be made.

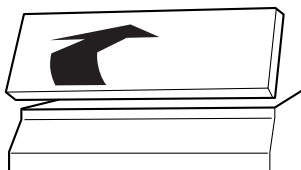

3. Lift up the front of the storage bin and pull it out.

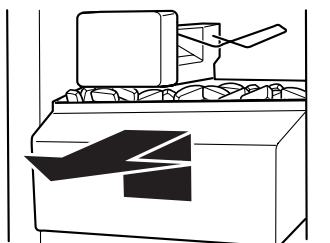

4. Replace the bin by pushing it in all the way or the dispenser will not work. Push the wire shut-off arm down to the ON position to restart ice production. Make sure the door is closed tightly.

To care for ice storage bin or bucket:

1. Empty the ice container. Use warm water to melt the ice if necessary. **Never use anything sharp** to break up the ice in the bin or bucket. This can cause damage to the ice container and the dispenser mechanism.
2. Wash with a mild detergent, rinse well and dry thoroughly. Do not use harsh or abrasive cleaners or solvents.

REMEMBER:

- Allow 24 hours to produce the first batch of ice.
- Discard the first three batches of ice produced to avoid impurities that may be flushed out of the system.
- The quality of your ice will be only as good as the quality of the water supplied to your ice maker.
- Avoid connecting the ice maker to a softened water supply. Water softener chemicals (such as salt) can damage parts of the ice maker and lead to poor quality ice. If a softened water supply cannot be avoided, make sure the water softener is operating properly and is well maintained.
- It is normal for the ice cubes to be attached at the corners. They will break apart easily.
- Do not force the wire shut-off arm up or down.
- Do not store anything on top of the ice maker or in the ice storage bin.

Freezer Shelf

To remove and replace the shelf:

1. Remove the shelf by lifting it up and pulling it straight out.
2. Replace the shelf by putting it over the supports and lowering it into place.

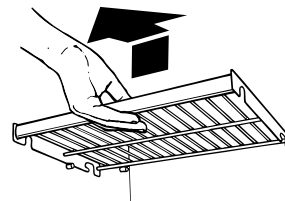

Frozen food storage guide

Storage times will vary according to the quality and type of food, the type of packaging or wrap used (should be airtight and moisture-proof), and the storage temperature. Ice crystals inside a sealed package are normal. This simply means that moisture in the food and air inside the package have condensed, creating ice crystals.

Put no more unfrozen food into the freezer than will freeze within 24 hours (no more than 2-3 lb of food per cubic foot [907-1,350 g per L] of freezer space). Leave enough space in the freezer for air to circulate around packages. Be careful to leave enough room for the door to close tightly.

For more information on preparing food for freezing, check a freezer guide or reliable cookbook.

Freezer Basket

(plastic bin on some models)

The freezer basket can be used to store bags of frozen fruits and vegetables that may slide off freezer shelves.

To remove and replace the freezer basket:

1. Remove basket by sliding it out to the stop.
2. Lift the front of the basket and slide it out the rest of the way.

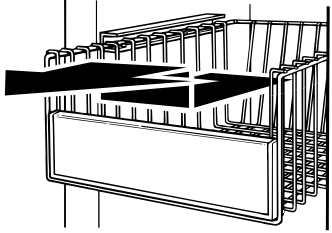

3. Replace the basket by positioning it on the side wall guide rails. Lift the basket front slightly while pushing it past the guide rail stops and slide basket in the rest of the way.

DOOR FEATURES

Your model may have some or all of these features. Features that can be purchased separately as product accessories are labeled with the word "Accessory." Not all accessories will fit all models. If you are interested in purchasing one of the accessories, please call the toll-free number on the cover or in the "Assistance or Service" section.

Door Rails

The door rails may be removed for easier cleaning.

Snap-on Door Rails

To remove and replace the rails:

1. Remove the rails by pushing in slightly on the front of the bracket while pulling out on the inside tab. Repeat these steps for the other end of the rail.
2. Replace the rails by aligning the ends of the brackets with the buttons on the sides of the door liner. Firmly snap bracket and rail assembly onto the tabs above the shelf as shown.



Drop-in Door Rails

To remove and replace the rails:

1. Remove the rails by pulling straight up on each end of the rail.
2. Replace the rails by sliding the shelf rail into the slots on the door and pushing the rail straight down until it stops.

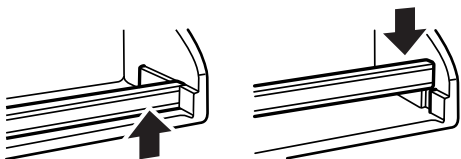

Door Bins

Large door bins hold gallon containers and the smaller door bins hold two-liter bottles. The door bins are removable for easy cleaning and adjusting.

NOTE: Place large door bins in the upper part of the refrigerator door so the door will close properly. Small door bins will fit in either the upper or lower part of the door.

To remove and replace the door bins:

1. Remove the bin by lifting it up and pulling it out.
2. Replace the bin by insert the hooks into the slots on both sides of the refrigerator door. Push the bin down to lock it into place.

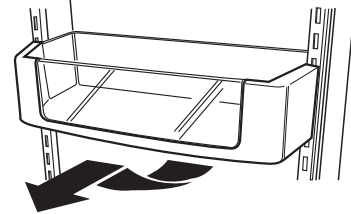

CARING FOR YOUR REFRIGERATOR

Cleaning Your Refrigerator

⚠ WARNING



Explosion Hazard

Use nonflammable cleaner.

Failure to do so can result in death, explosion, or fire.

Both the refrigerator and freezer sections defrost automatically. However, clean both sections about once a month to prevent odors from building up. Wipe up spills immediately.

To clean your refrigerator:

1. Unplug refrigerator or disconnect power.
2. Remove all removable parts from inside, such as shelves, crispers, etc.

3. Hand wash, rinse, and dry removable parts and interior surfaces thoroughly. Use a clean sponge or soft cloth and a mild detergent in warm water.
 - Do not use abrasive or harsh cleaners such as window sprays, scouring cleansers, flammable fluids, cleaning waxes, concentrated detergents, bleaches or cleansers containing petroleum products on plastic parts, interior and door liners or gaskets.
 - Do not use paper towels, scouring pads, or other harsh cleaning tools. These can scratch or damage materials.
 - To help remove odors, you can wash interior walls with a mixture of warm water and baking soda (2 tbs to 1 qt. [26 g to .95 L] of water).

4. Wash stainless steel and painted metal exteriors with a clean sponge or soft cloth and a mild detergent in warm water. Do not use abrasive or harsh cleaners. Dry thoroughly with a soft cloth.

For additional protection against damage to painted metal exteriors, apply appliance wax (or auto paste wax) with a clean, soft cloth. Do not wax plastic parts.

5. Clean the condenser coils regularly. Coils may need to be cleaned as often as every other month. This may help save energy.

Style 1 - Condenser coils behind base grille:

- Remove the base grille (see the "Base Grille" section).
- Use a vacuum with an extended attachment to clean the condenser coils when they are dusty or dirty.
- Replace the base grille when finished.

Style 2 - Condenser coils in back of the refrigerator:

- Pull refrigerator out away from the wall (see the "Unpacking Your Refrigerator" section).
- Vacuum coils when they are dusty or dirty.
- Roll refrigerator back into place. Make sure to leave 1 in. (2.5 cm) between the cabinet back and the wall.
- Check to see if the refrigerator is level.

6. Plug in refrigerator or reconnect power.

Changing the Light Bulbs

NOTE: Not all appliance bulbs will fit your refrigerator. Be sure to replace the bulb with one of the same size and shape. The dispenser light requires a heavy duty 10-watt bulb. All other lights require a 40-watt appliance bulb. Replacement bulbs are available from your dealer.

1. Unplug refrigerator or disconnect power.
2. Remove light shield when applicable as shown.

NOTE: To clean a light shield, wash it with warm water and a liquid detergent. Rinse and dry the shield well.
3. Remove light bulb and replace with one of the same size, shape and wattage.
4. Replace light shield when applicable as shown.
5. Plug in refrigerator or reconnect power.

Dispenser Light (on some models)

Reach through the dispenser area to remove and replace light bulb.

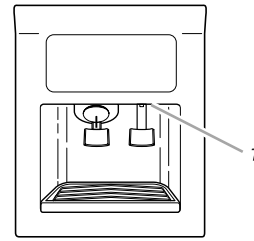

1. Dispenser Light

Control Panel Light

Reach behind the refrigerator control panel to remove and replace light bulb.

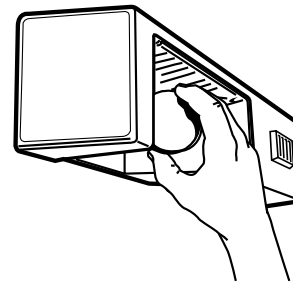

Crisper Light or Upper Freezer Light (on some models):

- Remove light shield by grasping the top center of the shield and pulling forward while turning it slightly to one side. If necessary, remove top crisper drawer to access crisper light shield.
- Replace the light shield by inserting the tabs on one end into the slotted holes in the refrigerator or freezer liner. Then, carefully bend the shield at the center to insert the tabs on the other end.



Lower Freezer Light (on some models) - (located beneath ice bin)

- Remove the light shield by grasping the sides and squeezing in towards the center. Once the side hooks of shield are free from the freezer lining, pull down the shield.
- Replace the light shield by squeezing the sides towards the center and inserting the side hooks into the slotted holes. Once the side hooks are in place, snap the front tab into the slotted hole.

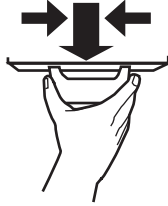

Power Interruptions

If the electricity in your house goes off, call the power company and ask how long it will be off.

1. If the power will be out for **24 hours or less, keep both refrigerator doors closed** to help food stay cold and frozen.
2. If the power will be out for **more than 24 hours:**
 - a) Remove all frozen food and store it in a frozen food locker.

OR

- b) Place 2 lbs. (907 g) of dry ice in the freezer for every cubic foot (28 L) of freezer space. This will keep the food frozen for two to four days.

OR

- c) If neither a food locker nor dry ice is available, consume or can perishable food at once.

REMEMBER: A full freezer stays cold longer than a partially filled one. A freezer full of meat stays cold longer than a freezer full of baked goods. If you see that food contains ice crystals, it may be refrozen, although the quality and flavor may be affected. If the condition of the food is poor, dispose of it.

Vacation and Moving Care

Vacations

If you choose to leave the refrigerator on while you're away, use these steps to prepare your refrigerator before you leave.

1. Use up any perishables and freeze other items.
2. If your refrigerator has an automatic ice maker:
 - Raise wire shut-off arm to OFF (up) position or move the switch to the OFF (right) setting.
 - Shut off water supply to the ice maker.
3. Empty the ice bin.

If you choose to turn the refrigerator off before you leave, follow these steps.

1. Remove all food from the refrigerator.
2. If your refrigerator has an automatic ice maker:
 - Turn off the water supply to the ice maker at least one day ahead of time.
 - When the last load of ice drops, raise the wire shut-off arm to the OFF (up) position or move the switch to the OFF (right) setting.
3. Depending on your model, turn the Thermostat Control or Refrigerator Control to OFF. See the "Setting the Controls" section.
4. Clean refrigerator, wipe it, and dry well.
5. Tape rubber or wood blocks to the tops of both doors to prop them open far enough for air to get in. This stops odor and mold from building up.

Moving

When you are moving your refrigerator to a new home, follow these steps to prepare it for the move.

1. If your refrigerator has an automatic ice maker:
 - Turn off the water supply to the ice maker at least one day ahead of time.
 - Disconnect the water line from the back of the refrigerator.
 - When the last load of ice drops, raise the wire shut-off arm to the OFF (up) position or move the switch to the OFF (right) setting.
2. Remove all food from the refrigerator and pack all frozen food in dry ice.
3. Empty the ice bin.
4. Depending on your model, turn the Thermostat Control or Refrigerator Control to OFF. See the "Setting the Controls" section.
5. Unplug the refrigerator.
6. Empty water from the defrost pan.
7. Clean, wipe, and dry thoroughly.
8. Take out all removable parts, wrap them well, and tape them together so they don't shift and rattle during the move.
9. Depending on the model, raise the front of the refrigerator so it rolls more easily OR screw in the leveling legs so they don't scrape the floor. See the "Door Closing" or "Leveling Your Refrigerator" section.
10. Tape the doors shut and the power cord to the refrigerator cabinet.

When you get to your new home, put everything back and refer to the "Installing Your Refrigerator" section for preparation instructions. Also, if your refrigerator has an automatic ice maker, remember to reconnect the water supply to the refrigerator.

TROUBLESHOOTING

Try the solutions suggested here first in order to avoid the cost of an unnecessary service call.

Your refrigerator will not operate

- **Is the power supply cord unplugged?**
Plug into a grounded 3 prong outlet.
 - **Has a household fuse or circuit breaker tripped?**
Replace the fuse or reset the circuit.
 - **Is the refrigerator or freezer control turned to the OFF position?**
Refer to the "Setting the Controls" section.
 - **Is the refrigerator defrosting?**
Recheck to see if the refrigerator is operating in 30 minutes. Your refrigerator will regularly run an automatic defrost cycle.
-

The lights do not work

- **Is the power supply cord unplugged?**
Plug into a grounded 3 prong outlet.
 - **Is a light bulb loose in the socket?**
Turn the refrigerator or freezer control to OFF. Disconnect the refrigerator from the electrical supply. Gently remove the bulb and reinsert. Then reconnect the refrigerator to the electrical supply and reset the control.
 - **Is a light bulb burned out?**
Replace with an appliance bulb of the same wattage, size, and shape. See the "Changing the Light Bulbs" section.
-

There is water in the defrost drain pan

- **Is the refrigerator defrosting?**
The water will evaporate. It is normal for water to drip into the defrost pan.
 - **Is it more humid than normal?**
Expect that the water in the defrost pan will take longer to evaporate. This is normal when it is hot or humid.
-

The motor seems to run too much

- **Is the room temperature hotter than normal?**
Expect the motor to run longer under warm conditions. At normal room temperatures, expect your motor to run about 40% to 80% of the time. Under warmer conditions, expect it to run even more of the time.
 - **Has a large amount of food just been added to the refrigerator?**
Adding a large amount of food warms the refrigerator. It is normal for the motor to run longer in order to cool the refrigerator back down.
 - **Is the door opened often?**
Expect the motor to run longer when this occurs. In order to conserve energy, try to get everything you need out of the refrigerator at once, keep food organized so it is easy to find, and close the door as soon as the food is removed.
 - **Are the controls not set correctly for the surrounding conditions?**
Refer to the "Setting the Controls" section.
-

- **Are the doors not closed completely?**
Push the doors firmly shut. If they will not shut all the way, see "The doors will not close completely" later in this section.
 - **Are the condenser coils dirty?**
This prevents air transfer and makes the motor work harder. Clean the condenser coils. Refer to the "Cleaning Your Refrigerator" section.
 - **Are the door gaskets not sealed all the way around?**
Contact a qualified person or a technician.
- NOTE:** If the problem is not due to any of the above, remember that your new refrigerator will run longer than your old one due to its high efficiency motor.
-

The refrigerator seems to make too much noise

- **The sounds may be normal for your refrigerator.**
Refer to the "Understanding Sounds You May Hear" section.
-

The ice maker is not producing ice

- **Is the freezer temperature not cold enough to produce ice?**
Wait 24 hours after ice maker hook-up for ice production. Refer to the "Setting the Controls" section.
 - **Is the ice maker wire shut-off arm in the OFF (wire shut-off arm up) position (on some models)?**
Lower wire shut-off arm to the ON (wire shut-off arm down) position. See the "Ice Maker and Storage Bin/Bucket" section.
 - **Is the ice maker switch in the OFF (right) position (on some models)?**
Move ice maker switch to the ON (left) position. See the "Ice Maker and Storage Bin/Bucket" section.
 - **Is the water line shut-off valve to the refrigerator not turned on?**
Turn on the water valve. See the "Connecting the Refrigerator to a Water Source" section.
 - **Is an ice cube jammed in the ejector arm?**
For models with an interior ice bin, remove the ice from the ejector arm with a plastic utensil. For models with an ice bucket, access the ice maker by depressing the ice bin sensor door on the upper left side of the freezer interior. While depressing the sensor door, lift the ice maker service door and remove the ice from the ejector with a plastic utensil. Refer to the "Ice Maker and Storage Bin/Bucket" section.
 - **Does the ice maker mold have water in it?**
Check to see if your refrigerator has been connected to your home water supply and the supply shut-off valve is turned on. Refer to the "Connecting the Refrigerator to a Water Source" section.
- NOTE:** If not due to any of the above, there may be a problem with the water line. Call for service.
-

The ice maker is producing too little ice

- **Has the ice maker just been installed?**
Wait 72 hours for full ice production to begin. Once your refrigerator is cooled down, the ice maker should begin producing 70 to 120 cubes every 24 hours.
- **Has a large amount of ice just been removed?**
Allow 24 hours for ice maker to produce more ice.
- **Are the controls set correctly?**
Refer to the "Setting the Controls" section.

- **Is the water shut-off valve turned completely on?**
Turn valve on fully. Refer to the “Connecting the Refrigerator to a Water Source” section.
- **Is there a water filter installed on the refrigerator?**
The filter may be clogged or installed incorrectly. First, check the filter installation instructions to ensure that the filter was installed correctly and is not clogged. If installation or clogging is not a problem, call a qualified person or a technician.

Off-taste, odor or grey color in the ice

- **Are the plumbing connections new, causing discolored or off-flavored ice?**
Discard the first few batches of ice.
- **Have the ice cubes been stored for too long?**
Throw old ice away and make a new supply.
- **Does the freezer and ice bin or bucket need to be cleaned?**
See the “Cleaning Your Refrigerator” or “Ice Maker and Storage Bin/Bucket” section.
- **Has food in the freezer or refrigerator been wrapped properly?**
Use airtight, moisture-proof packaging to help prevent odor transfer to stored food.
- **Does the water contain minerals (such as sulfur)?**
A filter may need to be installed to remove the minerals.
- **Is there a water filter installed on the refrigerator?**
Grey or dark discoloration in ice indicates that the water filtration system needs additional flushing. Run additional water through the water dispenser to flush the water filtration system more thoroughly (at least 2 to 3 gallons or 6 to 7 minutes initially). Discard discolored ice.

The ice dispenser will not operate properly

- **Is the freezer door closed completely?**
Push the door firmly shut. If it will not shut all the way, see “The doors will not close completely” later in this section.
- **Is the ice bin or bucket installed correctly?**
For models with an interior ice bin, push the ice bin in all the way. If the ice bin does not go in all the way, it may not be put in straight. Pull it out and try again. For models with an ice bucket, the bucket should set level on the freezer door. To remove the bucket, press the release button on the right side of the bucket and lift straight up. Replace the bucket in the door making sure it is properly aligned and snapped securely into place. Refer to the “Ice Maker and Storage Bin/Bucket” section.
- **Has the wrong ice been added to the bin or bucket?**
Use only cubes produced by the current ice maker. If other cubes have been added, remove all cubes and check to see that none have become stuck in the delivery chute.
- **Has the ice frozen in the ice bin or bucket?**
Shake the ice bin or bucket to separate cubes. If cubes do not separate, empty bin or bucket and wait 24 hours for ice to restock.
- **Has the ice melted around the auger (metal spiral) in the ice bucket?**
Dump the ice cubes and clean the ice bucket completely. Allow 24 hours for the ice maker to restock. Do not try to remove the melted ice with a sharp object. You could damage the ice bucket.

- **Is ice stuck in the delivery chute?**
Clear the ice from the delivery chute with a plastic utensil. Do not use anything sharp to remove the ice. You could cause damage.
- **Is there ice in the bucket?**
See “The ice maker is not producing ice” earlier in this section.
- **Has the dispenser arm been held in too long?**
Release dispenser arm. Ice will stop dispensing when the arm is held in too long. Wait three minutes for dispenser motor to reset before using again. (For future use, take large amounts of ice directly from the ice bin or bucket, so that the dispenser arm is not held in too long.)

The water dispenser will not operate properly

- **Is the freezer door not closed completely?**
Push the door firmly shut. If it will not shut all the way, see “The doors will not close completely” later in this section.
- **Has the water system not filled?**
The water system needs to be filled the first time it is used. Depress the water dispenser bar with a large container until you draw two or three quarts (1.9 to 2.8 L) of water. Discard water. Refer to the “Water and Ice Dispensers” section for further instructions on filling the water system.
- **Is the water shut-off valve not turned on or the water line connected at the source?**
Check to be sure the water shut-off valve is turned on and the water source is connected to the refrigerator. Refer to the “Connecting the Refrigerator to a Water Source” section for directions.
- **Is the water shut-off valve clogged or incorrectly installed?**
Refer to the “Connecting the Refrigerator to a Water Source” section. If clogging or installation is not a problem, call for service or contact a plumber.
- **Is there a kink in the home water source line?**
If you find or suspect a kink in the water line, call for service.
- **Is there a water filter installed on the refrigerator?**
The filter may be clogged or incorrectly installed. First, check the filter installation instructions to ensure that the filter was installed correctly and is not clogged. If installation or clogging is not a problem, call for service.

Water or ice is leaking from the dispenser

- **Is the glass not being held under the ice dispenser long enough, causing the ice to spill?**
Hold the container under the ice chute for two to three seconds after releasing the dispenser lever. A small amount of ice may dispense after the lever is released.
- **Is the glass not being held under the water dispenser long enough, causing water to drip?**
Hold the container under the water dispenser two to three seconds after releasing the dispenser lever. Water may continue to dispense during this time.
- **Is an ice cube stuck in the chute and holding the trap door open?**
Remove the cube.
- **Is there a water filter installed on the refrigerator?**
The water filtration system may have air in the lines, causing water to drip. Additional flushing may help clear air from the lines. Normal dispenser use should flush air from the lines within 24 to 72 hours.

The dispenser water is not cool enough

- **Has the refrigerator been newly installed?**
Allow 24 hours for the refrigerator to cool completely.
- **Has a large amount of water been recently dispensed?**
Allow 24 hours for the water to cool completely.
- **Has water not been recently dispensed?**
The first glass of water may not be cool. Discard the first glass of water.

The divider between the two compartments is warm

- The warmth is probably due to normal operation of the automatic exterior moisture control. If still concerned, call for service.

Temperature is too warm

- **Are the air vents blocked in either compartment? This prevents the movement of cold air from the freezer to the refrigerator.**
Remove any objects from in front of the air vents. Refer to the "Ensuring Proper Air Circulation" section for the location of air vents.
- **Are the door(s) opened often?**
Be aware that the refrigerator will warm when this occurs. In order to keep the refrigerator cool, try to get everything you need out of the refrigerator at once, keep food organized so it is easy to find, and close the door as soon as the food is removed.
- **Has a large amount of food just been added to the refrigerator or freezer?**
Adding a large amount of food warms the refrigerator. It can take several hours for the refrigerator to return to the normal temperature.
- **Are the controls set correctly for the surrounding conditions?**
Refer to the "Setting the Controls" section.

There is interior moisture build-up

- **Are the air vents blocked in the refrigerator?**
Remove any objects from in front of the air vents. Refer to the "Ensuring Proper Air Circulation" section for the location of air vents.
- **Are the door(s) opened often?**
To avoid humidity build-up, try to get everything you need out of the refrigerator at once, keep food organized so it is easy to find, and close the door as soon as the food is removed. (When the door is opened, humidity from the room air enters the refrigerator. The more often the door is opened, the faster humidity builds up, especially when the room itself is very humid.)
- **Is the room humid?**
It is normal for moisture to build up inside the refrigerator when the room air is humid.

- **Is the food packaged correctly?**
Check that all food is securely wrapped. Wipe off damp food containers before placing in the refrigerator.
- **Are the controls set correctly for the surrounding conditions?**
Refer to the "Setting the Controls" section.
- **Was a self-defrost cycle completed?**
It is normal for droplets to form on the back wall after the refrigerator self-defrosts.

The doors will not close completely

- **Are food packages blocking the door open?**
Rearrange containers so that they fit more tightly and take up less space.
- **Is the ice bin or ice bucket out of position?**
For models with an interior ice bin, push the ice bin in all the way. If the ice bin does not go in all the way, it may not be put in straight. Pull it out and try again. For models with an ice bucket, the bucket should set level on the freezer door. To remove the bucket, press the release button on the right side of the bucket and lift straight up. Replace the bucket in the door making sure it is properly aligned and snapped securely into place. Refer to the "Ice Maker and Storage Bin/Bucket" section.
- **Are the pans, shelves, bins, or baskets out of position?**
Put the crisper cover and all pans, shelves, bins, and baskets back into their correct positions. See the "Crisper and Crisper Cover" section for more information.
- **Are the gaskets sticking?**
Clean gaskets according to the directions in the "Cleaning Your Refrigerator" section.
- **Does the refrigerator wobble or seem unstable?**
Level the refrigerator. Refer to the "Door Closing" or "Leveling Your Refrigerator" section, depending on your model.
- **Were the doors removed during product installation and not properly replaced?**
Remove and replace the doors according to the "Removing the Doors" section on some models, or call a qualified service technician.

The doors are difficult to open

- **Are the gaskets dirty or sticky?**
Clean gaskets according to the directions in the "Cleaning Your Refrigerator" section.

Water flow from the dispenser decreases noticeably

- **Is there a water filter installed on the refrigerator?** The filter may be full or incorrectly installed. Depending on your model, remove the water filter cartridge (see the "Base Grille Water Filtration and Monitoring System or Interior Water Filtration System" section.) Operate the dispenser. If the water flow increases noticeably, your filter is full and needs to be replaced.

ASSISTANCE OR SERVICE

Before calling for assistance or service, please check "Troubleshooting." It may save you the cost of a service call. If you still need help, follow the instructions below.

When calling, please know the purchase date and the complete model and serial number of your appliance. This information will help us to better respond to your request.

If you need replacement parts

If you need to order replacement parts, we recommend that you only use FSP® replacement parts. FSP® replacement parts will fit right and work right because they are made with the same precision used to build every new KITCHENAID® appliance.

To locate FSP® replacement parts in your area, call our Consumer Assistance Center telephone number or your nearest designated service center.

In the U.S.A.

Call the KitchenAid Consumer Assistance Center toll free: **1-800-422-1230**.

Our consultants provide assistance with:

- Features and specifications on our full line of appliances.
- Installation information.
- Use and maintenance procedures.
- Accessory and repair parts sales.
- Specialized customer assistance (Spanish speaking, hearing impaired, limited vision, etc.).
- Referrals to local dealers, repair parts distributors, and service companies. KitchenAid designated service technicians are trained to fulfill the product warranty and provide after-warranty service, anywhere in the United States.

To locate the KitchenAid designated service company in your area, you can also look in your telephone directory Yellow Pages.

For further assistance

If you need further assistance, you can write to KitchenAid with any questions or concerns at:

KitchenAid Brand Home Appliances
Consumer Assistance Center
c/o Correspondence Dept.
2000 North M-63
Benton Harbor, MI 49022-2692

Please include a daytime phone number in your correspondence.

In Canada

Call the KitchenAid Canada Consumer Assistance Center toll free: **1-800-461-5681** 8:30 a.m. - 6:00 p.m. (EST).

Our consultants provide assistance with:

- Features and specifications on our full line of appliances.
- Referrals to local dealers.

For service in Canada

Call **1-800-807-6777**. KitchenAid Canada designated service technicians are trained to fulfill the product warranty and provide after-warranty service, anywhere in Canada.

For further assistance

If you need further assistance, you can write to KitchenAid Canada with any questions or concerns at:

Consumer Relations Center
KitchenAid Canada
1901 Minnesota Court
Mississauga, Ontario L5N 3A7

Please include a daytime phone number in your correspondence.

Accessories

To order accessories, call **1-800-422-1230** and ask for the appropriate part number listed below or contact your authorized KitchenAid dealer. In Canada, call **1-800-807-6777**.

Installation Trim kits:

Part #2208187S - Stainless Trim Kit
Part #2208187W - White Trim Kit
Part #2208187B - Black Trim Kit
Part #2208187T - Biscuit Trim Kit

Base grille water filter cartridges:

Standard Cartridge:

Order Part #4392857 (NL-300 and L500)

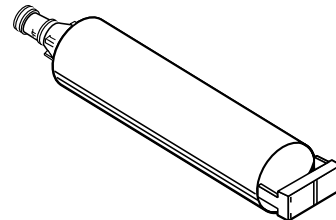

KITCHENAID® REFRIGERATOR WARRANTY

ONE-YEAR FULL WARRANTY ON REFRIGERATOR

For one year from the date of purchase, when this refrigerator (excluding the water filter) is operated and maintained according to instructions attached to or furnished with the product, KitchenAid will pay for factory specified replacement parts and repair labor costs to correct defects in materials or workmanship. Service must be provided by a KitchenAid designated service company.

On models with a water filter: 30 day limited warranty on water filter. For 30 days from the date of purchase, when this filter is operated and maintained according to instructions attached to or furnished with the product, KitchenAid will pay for replacement parts to correct defects in materials and workmanship.

SECOND THROUGH FIFTH YEAR FULL WARRANTY

In second through fifth years from the date of purchase, KitchenAid will pay for replacement or repair of the refrigerator/freezer cavity liner (including labor costs) if the part cracks due to defective materials or workmanship. Service must be provided by a KitchenAid designated service company.

Also, KitchenAid will pay for factory specified replacement parts and repair labor costs to correct defects in materials or workmanship in the sealed refrigeration system. These parts are: compressor, evaporator, condenser, dryer, and connecting tubing. Service must be performed by a KitchenAid designated service company.

SIXTH THROUGH TENTH YEAR LIMITED WARRANTY

In sixth through tenth years from date of purchase, KitchenAid will pay for factory specified replacement parts to correct defects in materials or workmanship in the sealed refrigeration system. These parts are: compressor, evaporator, condenser, dryer, and connecting tubing.

LIMITED LIFETIME WARRANTY

In second year through life of product from date of purchase, KitchenAid will pay for replacement of all SLIDE N LOCK™ Door Bins and SLIDE N LOCK™ Can Racks due to defective materials or workmanship.

KitchenAid will not pay for:

1. Service calls to correct the installation of your refrigerator, to instruct you how to use your refrigerator, to replace house fuses or correct house wiring or plumbing, to replace light bulbs, or replacement water filters other than as noted above.
 2. Repairs when your refrigerator is used in other than normal, single-family household use.
 3. Pickup and delivery. Your refrigerator is designed to be repaired in the home.
 4. Damage resulting from accident, alteration, misuse, abuse, fire, flood, improper installation, acts of God, or use of products not approved by KitchenAid or KitchenAid Canada.
 5. Any food loss due to product failure.
 6. Repairs to parts or systems resulting from unauthorized modifications made to the appliance.
 7. Replacement parts or repair labor costs for units operated outside the United States or Canada.
 8. In Canada, travel or transportation expenses for customers who reside in remote areas.
 9. Any labor costs during the limited warranty period.
-

KITCHENAID AND KITCHENAID CANADA SHALL NOT BE LIABLE FOR INCIDENTAL OR CONSEQUENTIAL DAMAGES.

Some states or provinces do not allow the exclusion or limitation of incidental or consequential damages, so this exclusion or limitation may not apply to you. This warranty gives you specific legal rights, and you may also have other rights which vary from state to state or province to province.

Outside the 50 United States and Canada, this warranty does not apply. Contact your authorized KitchenAid dealer to determine if another warranty applies.

If you need service, first see the "Troubleshooting" section of this book. After checking "Troubleshooting," additional help can be found by checking the "Assistance or Service" section or by calling the KitchenAid Consumer Assistance Center, 1-800-422-1230 (toll-free), from anywhere in the U.S.A. In Canada, contact your designated KitchenAid Canada Appliance service company or call 1-800-807-6777. **11/99**

Keep this book and your sales slip together for future reference. You must provide proof of purchase or installation date for in-warranty service.

Write down the following information about your refrigerator to better help you obtain assistance or service if you ever need it. You will need to know your complete model number and serial number. You can find this information on the model and serial number label located on the inside wall of the refrigerator compartment.

Dealer name _____

Address _____

Phone number _____

Model number _____

Serial number _____

Purchase date _____

WATER FILTER CERTIFICATIONS

State of California
Department of Health Services
Water Treatment Device
Certificate Number

98 - 1344

Date Issued: June 9, 1998

State of California
Department of Health Services
Water Treatment Device
Certificate Number

98 - 1343

Date Issued: June 9, 1998

<u>Trademark/Model Designation</u>	<u>Replacement Elements</u>
WF-NL300	NL300
Manufacturer: Whirlpool Corp.	

The water treatment device(s) listed on this certificate have met the testing requirements pursuant to Section 116830 of the Health and Safety Code for the following health related contaminants:

<u>Microbiological Contaminants and Turbidity</u>	<u>Inorganic/Radiological Contaminants</u>
None	Lead

Organic Contaminants
None

<u>Trademark/Model Designation</u>	<u>Replacement Elements</u>
WF-L500	L500
Manufacturer: Whirlpool Corp.	

The water treatment device(s) listed on this certificate have met the testing requirements pursuant to Section 116830 of the Health and Safety Code for the following health related contaminants:

<u>Microbiological Contaminants and Turbidity</u>	<u>Inorganic/Radiological Contaminants</u>
None	Lead

Organic Contaminants
None

Rated Service Capacity: 300 gallons **Rated Service Flow:** 0.5 gpm

Do not use with water that is microbiologically unsafe or of unknown quality, without adequate disinfection before or after the system.

Rated Service Capacity: 500 gallons **Rated Service Flow:** 0.5 gpm

Do not use with water that is microbiologically unsafe or of unknown quality, without adequate disinfection before or after the system.

PRODUCT DATA SHEETS

Base Grille Water Filtration System Model WF-NL300/NL300



Tested and certified by NSF International against ANSI/NSF Standard 42 for the reduction of Chlorine (Class I) Taste and Odor and against ANSI/NSF Standard 53 for the reduction of Lead.

Capacity: 300 Gallons (1136 Liters)
Service Flow Rate: 0.5 GPM (1.89 L/min.) @ 60 psi.

Substance Reduction		Average Influent	Maximum Effluent	Average Effluent	Minimum % Reduction	Average % Reduction	NSF Test Number
Chlorine, Taste/Odor		2.0 mg/L	N/A	0.1 mg/L	N/A	95%	981788
Contaminant Reduction Performance**	U.S. EPA MCL	Average Influent	Maximum Effluent	Average Effluent	Minimum% Reduction	Average% Reduction	NSF Test Number
Lead: @ pH 6.5	0.015 mg/L	0.16 mg/L*	0.007 mg/L	0.005 mg/L	95%	97%	976115
Lead: @ pH 8.5	0.015 mg/L	0.14 mg/L*	0.012 mg/L	0.008 mg/L	91%	94%	976116

Base Grille Water Filtration System Model WF-L500/L500



Tested and certified by NSF International against ANSI/NSF Standard 42 for the reduction of Chlorine (Class I) Taste and Odor and against ANSI/NSF Standard 53 for the reduction of Lead.

Capacity: 500 Gallons (1893 Liters)
Service Flow Rate: 0.5 GPM (1.89 L/min.) @ 60 psi.

Substance Reduction		Average Influent	Maximum Effluent	Average Effluent	Minimum % Reduction	Average % Reduction	NSF Test Number
Chlorine, Taste/Odor		2.0 mg/L	N/A	0.1 mg/L	N/A	95%	981788
Contaminant Reduction Performance**	U.S. EPA MCL	Average Influent	Maximum Effluent	Average Effluent	Minimum% Reduction	Average% Reduction	NSF Test Number
Lead: @ pH 6.5	0.015 mg/L	0.16 mg/L*	0.007 mg/L	0.005 mg/L	95%	97%	976115
Lead: @ pH 8.5	0.015 mg/L	0.14 mg/L*	0.012 mg/L	0.008 mg/L	91%	94%	976116

- It is essential that operational, maintenance, and filter replacement requirements be carried out for the product to perform as advertised.
- Model WF-NL300** Change cartridge at least every 6-9 months. Use replacement cartridge NL 300, part# 4392857. 2000 Suggested retail price of \$29.95 U.S.A./\$39.95 Canada.
- Model WF-L500** The filter monitor system measures the amount of water that passes through the filter and alerts you to replace the filter. When 90% of the filter's rated life is used, the filter indicator light changes from green to yellow. When 100% of the filter's rated life is used, the filter indicator light changes from yellow to red, and it is recommended that you replace the filter. Use replacement cartridge L500, part# 4392857. 2000 Suggested retail price of \$29.95 U.S.A./\$39.95 Canada.
- The product is for cold water use only.
- Do not use with water that is microbiologically unsafe or of unknown quality without adequate disinfection before or after the system.
- Refer to the "Assistance or Service" section for the Manufacturer's name, address and telephone number.
- Refer to the "Warranty" section for the Manufacturer's limited warranty.

Application Guidelines/Water Supply Parameters

Water Supply	City or Well
Water Pressure	30 - 120 psi (207 - 827 kPa)
Water Temperature	33° - 100°F (0.6° - 37.8° C)

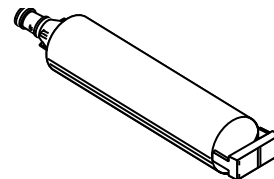

*Test requirement is 0.15 mg/L ± 10%.

**These contaminants are not necessarily in your water supply. Performance may vary based on local water conditions.

® NSF is a registered trademark of NSF International.

2210719

© 2000. All rights reserved.
Tous droits réservés.

® Registered Trademark/TM Trademark of KitchenAid, U.S.A., KitchenAid Canada licensee in Canada
® Marque déposée de KitchenAid/Marque de Commerce de KitchenAid, U.S.A., Emploi licencié par KitchenAid Canada

3/00
Printed in U.S.A.
Imprimé aux É.-U.

