

# BLAZE

BY SONANCE

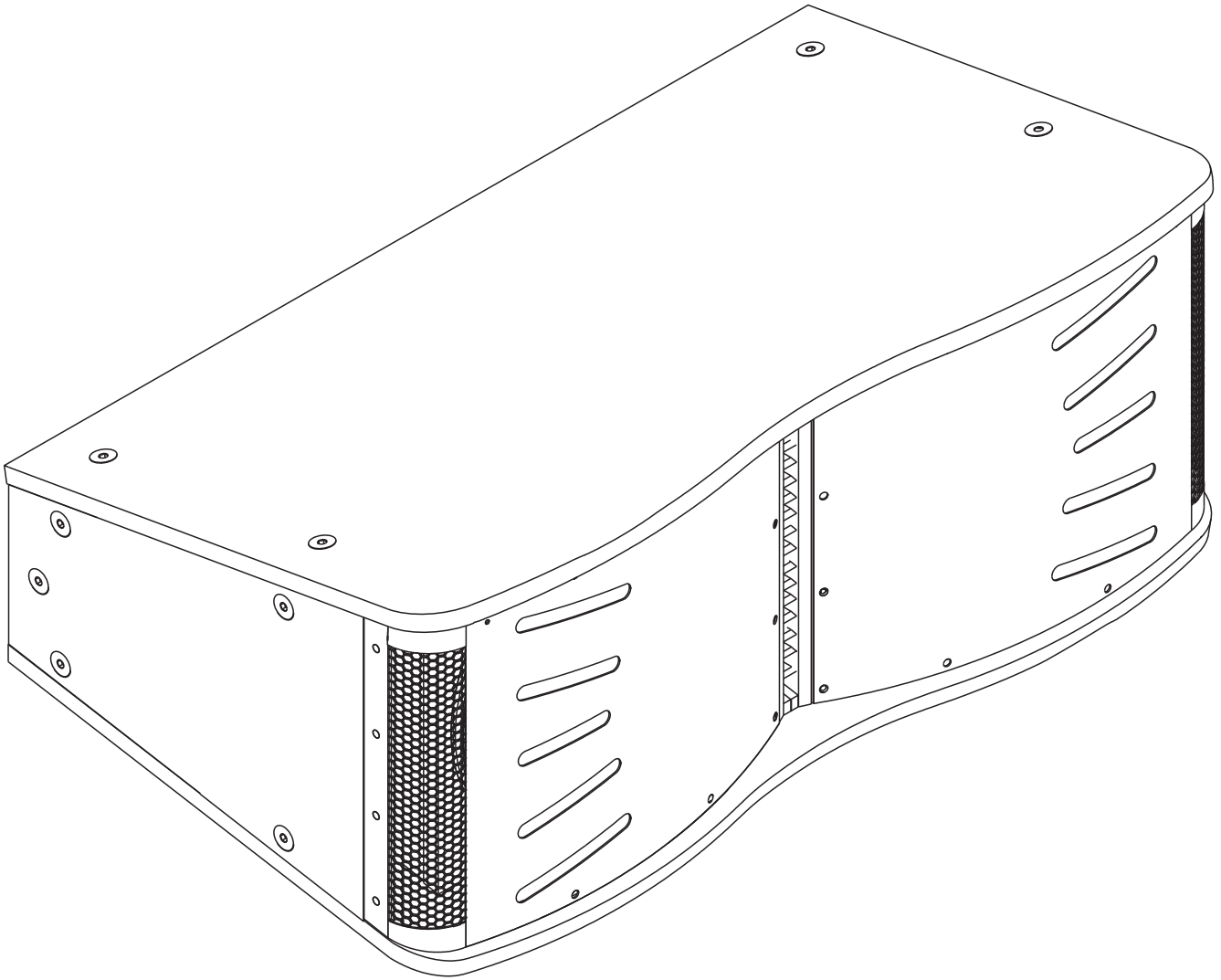

## INSTALLATION MANUAL

CCA10i-BA Loudspeakers

# 1. Introduction and Overview

## 1.1 Introduction

Thank you for purchasing a Blaze Audio CCA10i-BA loudspeaker. The CCA10i-BA is a constant curvature, arrayable point source loudspeaker, designed for medium-sized venues to large distributed systems that require a flexible and scalable loudspeaker solution. Mounted horizontally with tight acoustic centres to minimize comb filtering, each CCA10i-BA enclosure provides fixed 20° vertical and 160° horizontal coverage. CCA10i-BA loudspeakers are designed to be flown with additional enclosures in vertical arrays.

The CCA10i-BA features a coaxial compression driver employing individual midrange and high-frequency polymer ring diaphragms. The driver delivers extremely wide bandwidth from 420 Hz – 18,000 Hz. For low frequencies, dual 10" high-excursion drivers deliver efficient and accurate bass down to 52 Hz (-3 dB) with minimal distortion and power compression.

## 1.2 CCA10i-BA Pack Contents

In addition to this installation manual, Each CCA10i-BA package contains the items identified and illustrated below.

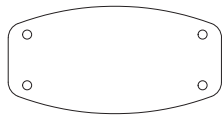
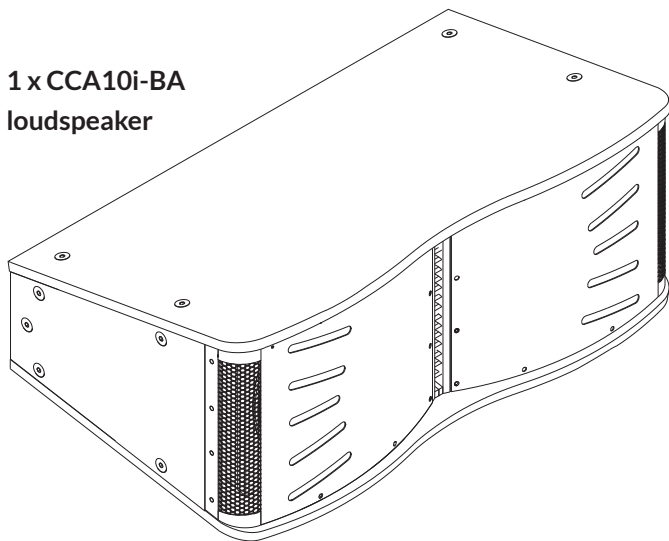

2 x CCA10i-BA Rigging Plates

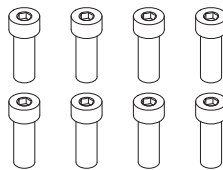
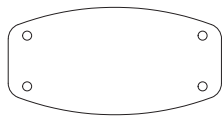

8 x M10x30 hex head bolts

Rigging Grid (aluminum)

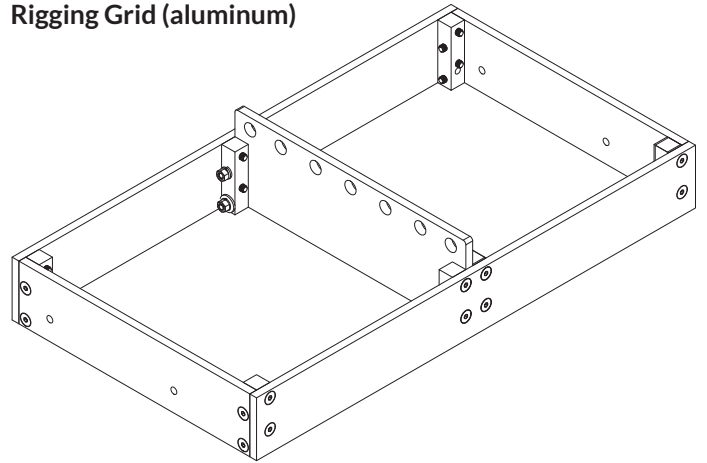

**Note:** A steel Rigging Grid is available to order for installations where specific structural and regulatory demands require it.

Rigging Extension Arm

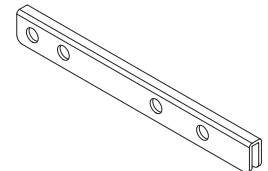

**Note:** Rigging accessories are supplied complete with the appropriate bolts, nuts, washers and other necessary attachment items.

## 1.3 Rigging Accessories

Rigging accessories that enable single or multiple CCA10i-BA loudspeakers to be flown are available separately from Blaze Audio. The rigging accessories are identified and illustrated alongside. **Instructions on the use of the rigging accessories can be found in Section 2.3 of this manual.**

## 2. Applications and Deployment

### 2.1 Applications

The CCA10i-BA can be configured as an individual point-source loudspeaker or in a vertical array with multiple CCA10i-BA loudspeakers. Integrated rigging enables easy and secure box-to-box deployment. Flying CCA10i-BA loudspeakers, requires the CCA10i-BA Rigging Grid. This separately sold item enables the suspension up to four (4) CCA10i-BA loudspeakers. Arrays of greater than four CCA10i-BA loudspeakers are possible but will require customized Blaze Audio rigging accessories. The basic CCA10i-BA rig, array and suspension principle is illustrated below however for all supported rigging configurations, see the chart in Section 2.3.



**IMPORTANT:** In all cases, when rigging loudspeakers together, attach the bottommost unit to the loudspeaker directly above it, moving up the array to the topmost unit, ending with the Rigging Grid.

**WARNING:** The CCA10i-BA weighs 83lbs / 37.65kg. Use proper lifting techniques to avoid serious injury. Please see Section 2.4 for Maximum Suspended Load.

**WARNING:** When assembling or disassembling arrayed loudspeakers, make sure that all components are properly supported throughout the entire process to avoid damage or injury.

**WARNING:** To ensure secure attachment, verify that the loudspeakers are properly aligned for box-to-box vertical attachment. If loudspeakers are not properly aligned, physical damage, and personal injury may occur. The top of each loudspeaker must be parallel to the bottom of the unit above it. For suspension, the topmost unit must be securely attached to the CCA10i-BA Rigging Grid.

### Basic CCA10i-BA Array Assembly

*Note: Left hand side of array shown.*

*Rigging Plate and Grid attachment must be duplicated on the right hand side.*

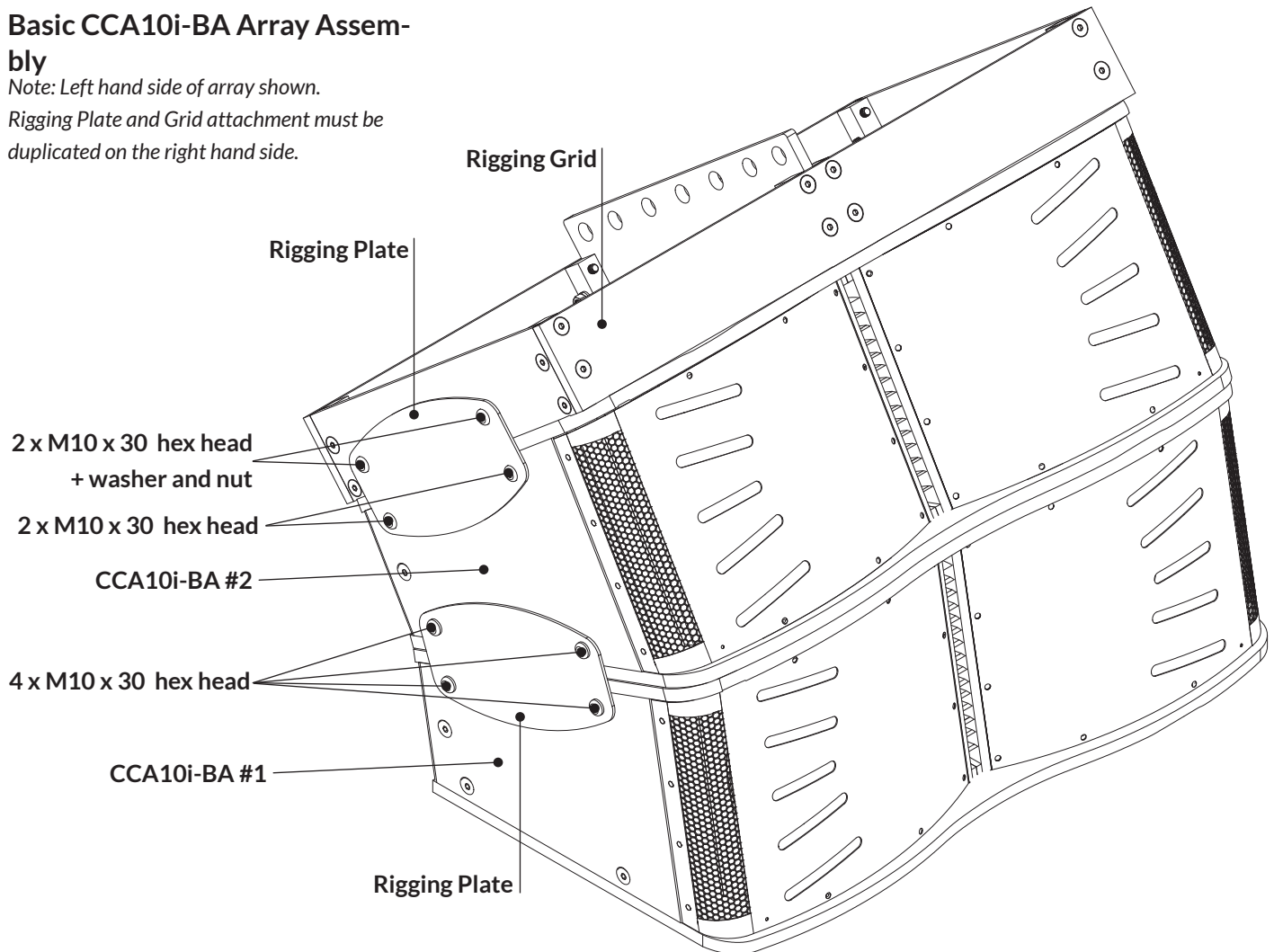

## 2. Applications and Deployment



### 2.2 Important Safety Instructions

**WARNING:** Failure to observe the following safety precautions may result in severe injury or death. Installations such as described in this guide should only be attempted by a trained professional.

- Read these instructions.
- Keep these instructions.
- Heed all warnings.
- Follow all instructions.
- Before installing or suspending any CCA10i-BA loudspeaker, inspect all hardware, the enclosure, and associated equipment for damage. Missing, corroded, or deformed components, or components without correct load ratings, could significantly reduce the strength of the installation or placement and should immediately be repaired or replaced.
- Always make sure that the structure the loudspeaker is to be suspended from has been approved by the building or structural engineer and will support the weight of all the components of the speaker system including speakers, speaker cable, wire rope, etc.
- Consult a licensed professional structural engineer regarding physical equipment installation.
- Do not suspend loudspeakers directly over people.
- Use only hardware that is rated for the load conditions of the installation and that allows for a possible short-term, unexpected overload. Never exceed the rating of the hardware or equipment.
- Blaze Audio strongly recommends that the system be inspected at least once a year and logged. If any sign of weakness or damage is detected, remedial action should be taken immediately.
- All installation crew members must be trained for loudspeaker rigging and mounting.
- Make sure that all relevant health and safety regulations are known, are followed by the installation crew, and follow applicable local laws. Local government offices can help with this information.
- Suspended installations must be completed or supervised by a certified rigger.
- The system should be designed so that it is a static suspension. There should be no dynamic or shock loading.
- Personal protective equipment (hard hats, steel-toed footwear, safety glasses, etc.) should be always worn by the installation crew.
- If called for in the design, make sure all installation personnel are trained to work at height and have certifications for scissor lifts, theatrical hoists, etc.
- Make sure all lifting equipment (slings, span-sets, deck chain, scaffolding, etc.) is in good working order. Thoroughly inspect all components prior to use.
- Inspect all the components associated with the project for damage before assembly. Any parts with damage or suspected damage should not be used. Contact the component manufacturer for replacement parts if necessary.
- Keep a tidy workplace. Do not leave tools, rigging items, etc., on top of loudspeakers during installation. Loose items can fall and cause injury.
- Never leave the system unattended during the installation process. Make sure that the workspace is isolated from public access. No one should be allowed to pass beneath the loudspeakers during installation.
- Do not suspend any other components or loudspeakers other than the supported configurations described in this manual.
- If secondary steel safeties are required, they should be installed once the entire system is at operating height and before public access is allowed.

## 2. Applications and Deployment

### 2.3 Rigging Instructions

CCA10i-BA loudspeakers feature integrated rigging hardware. Use of the rigging hardware is similar whether multiple CCA10i-BA loudspeakers are to be joined, or are to be attached to a CCA10i-BA Rigging Grid.

#### 2.3.1 Connecting One CCA10i-BA to Another

**Step 1.** On the bottom CCA10i-BA loudspeaker remove the two upper-most countersunk M10 bolts on the left and right sides. The bolts can be discarded.

Remove and discard  
(repeat on other side)

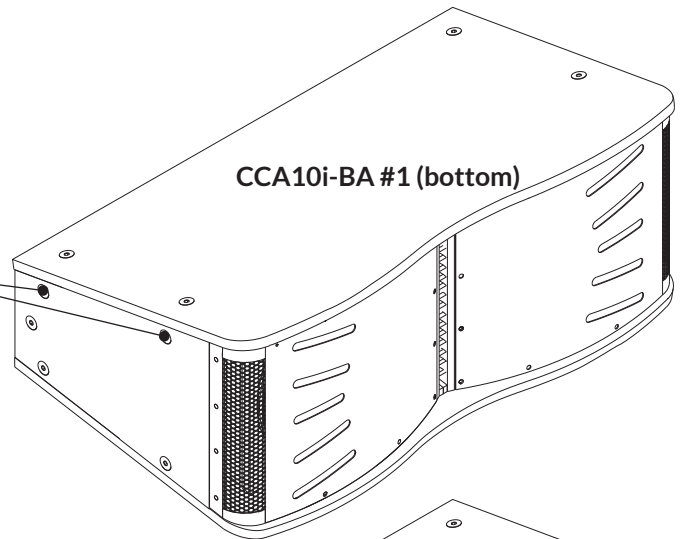

**Step 2.** On the top CCA10i-BA loudspeaker remove the two lower-most countersunk M10 bolts on the left and right sides. The bolts can be discarded.

Remove and discard  
(repeat on other side)

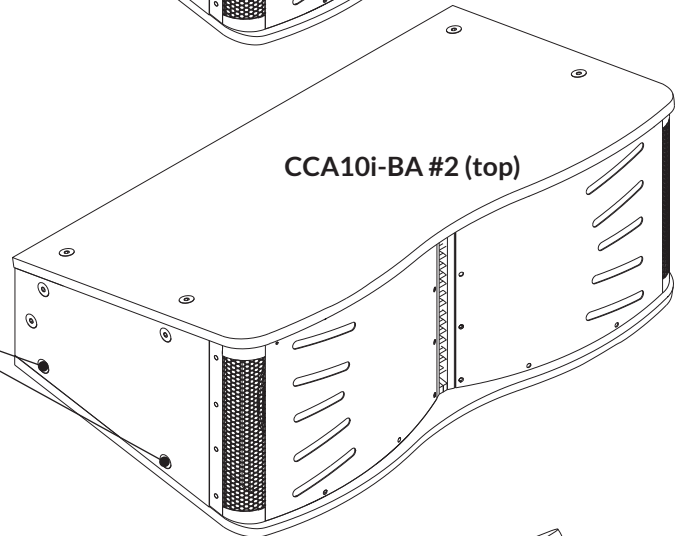

**Step 3.** Align the top CCA10i-BA loudspeaker over the bottom CCA10i-BA loudspeaker and install the provided **Rigging Plates** between the two enclosures on the left and right sides. Secure the **Rigging Plates** using the supplied M10 hex head bolts.

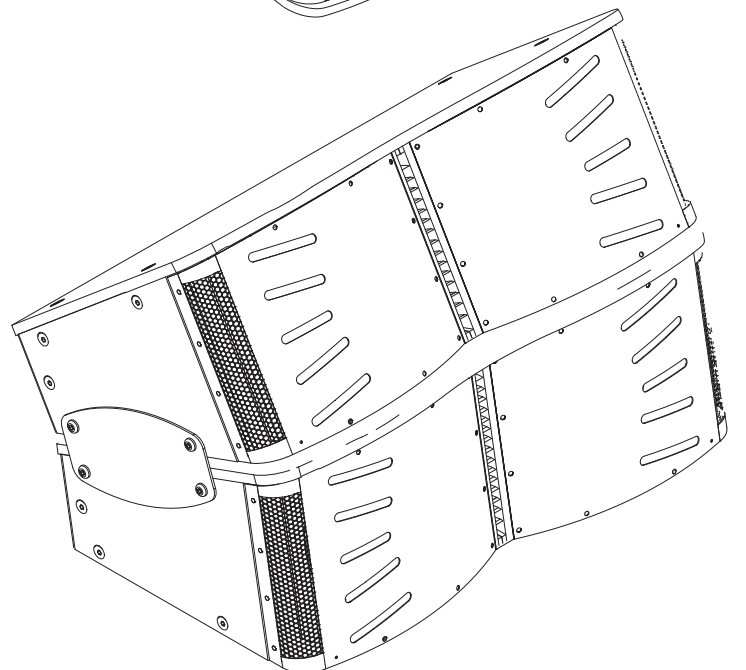

## 2. Applications and Deployment

### 2.3 Rigging Instructions

CCA10i-BA loudspeakers feature integrated rigging hardware. Use of the rigging hardware is similar whether multiple CCA10i-BA loudspeakers are to be joined, or are to be attached to a CCA10i-BA Rigging Grid.

#### 2.3.2 Connecting a CCA10i-BA to a Rigging Grid

**Step 1.** Remove the two upper-most countersunk M10 bolts on the loudspeaker on both the left and right sides. The bolts can be discarded.

Remove and discard  
(repeat on other side)

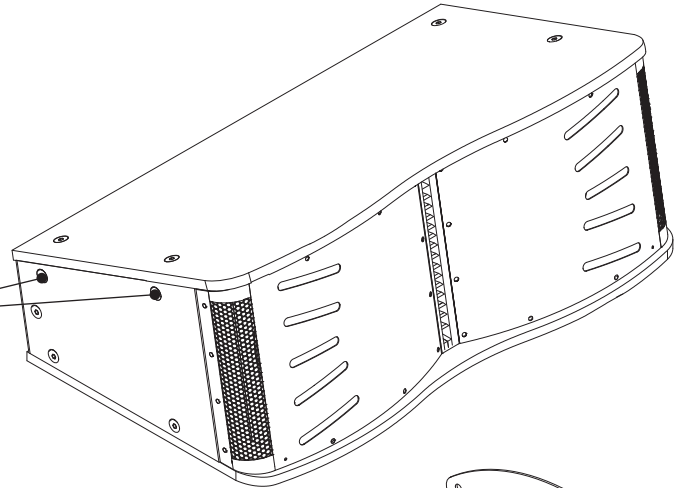

**Step 2.** Attach one of the supplied Rigging Plates to each side of the enclosures. Secure the Rigging Plates using the supplied M10 hex head bolts.

Rigging Plate  
(pair on other side)

2 x M10 x 30 hex head bolts  
(repeat on other side)

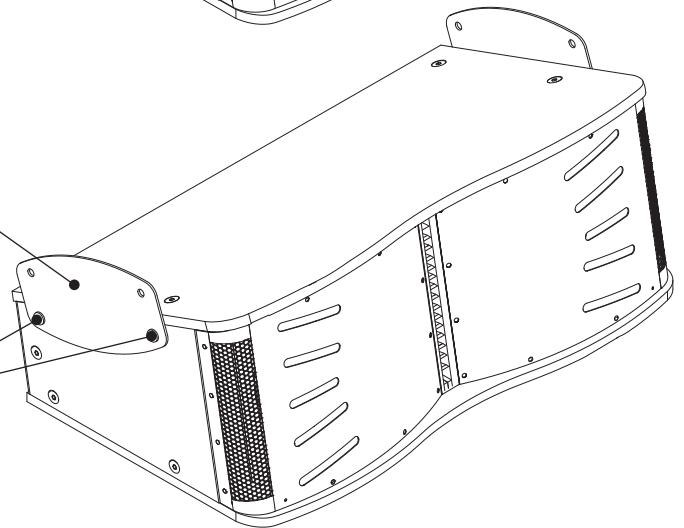

**Step 3.** Place the Rigging Grid on the top of the loudspeaker and align its attachment holes with the corresponding holes in the left and right Rigging Plates. Secure the Rigging Grid to the Rigging Plates using the supplied M10 hex head bolts with the supplied lock washers and nuts.

2 x M10 lock washers and nuts  
(repeat on other side)

Rigging Grid

2 x M10 x 30 hex head bolts  
(repeat on other side)

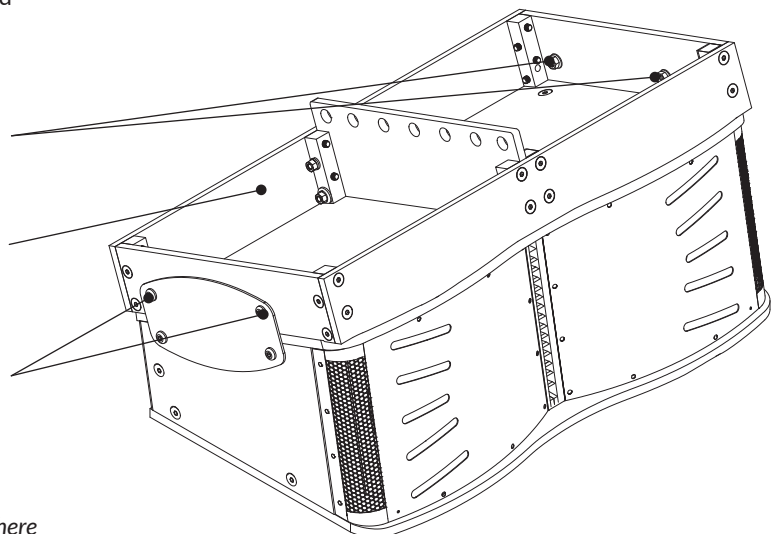

**Note:** A steel Rigging Grid is available to order for installations where specific structural and regulatory demands require it.

## 2. Applications and Deployment

### 2.3 Rigging Instructions

CCA10i-BA loudspeakers feature integrated rigging hardware. Use of the rigging hardware is similar whether multiple CCA10i-BA loudspeakers are to be joined, or are to be attached to a CCA10i-BA Rigging Grid.

#### 2.3.3 Attaching the Rigging Grid Extension Arm

The **Rigging Grid Extension Arm** can be used when it is required to alter the vertical angle of suspended CCA10i-BA loudspeakers.

**Step 1.** Attach a **Rigging Grid** as described in Section 2.3.3 of this manual to a single, or an array of multiple, CCA10i-BA loudspeakers.

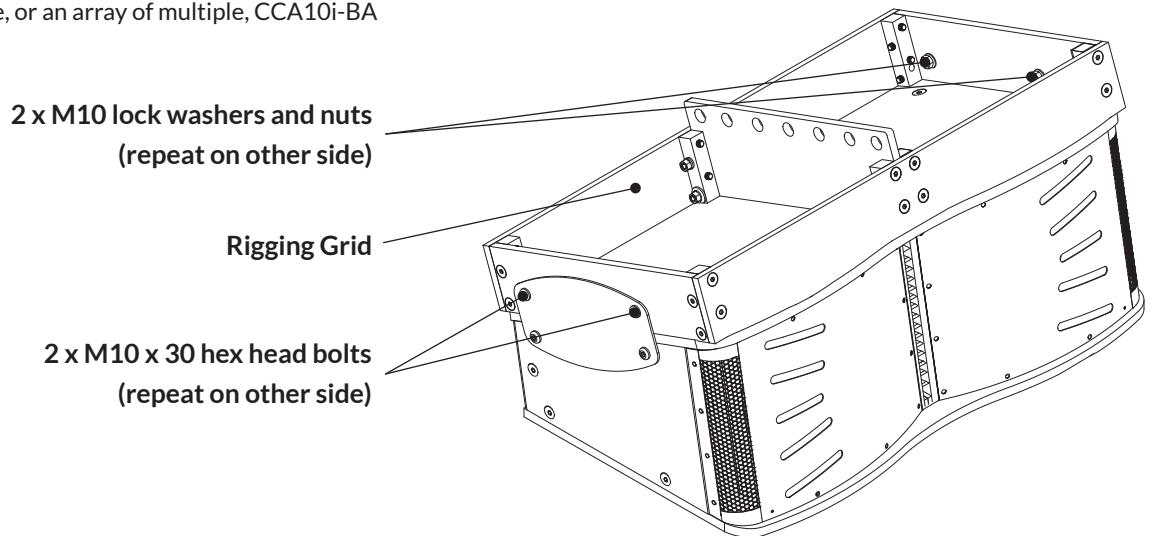

**Step 2.** Position the **Rigging Grid Extension Arm** on the central spine of the **Rigging Grid** at either the front or the back of the assembly depending on the suspension angle adjustment required. Secure the **Rigging Grid Extension Arm** using the supplied clevis and cotter pins.

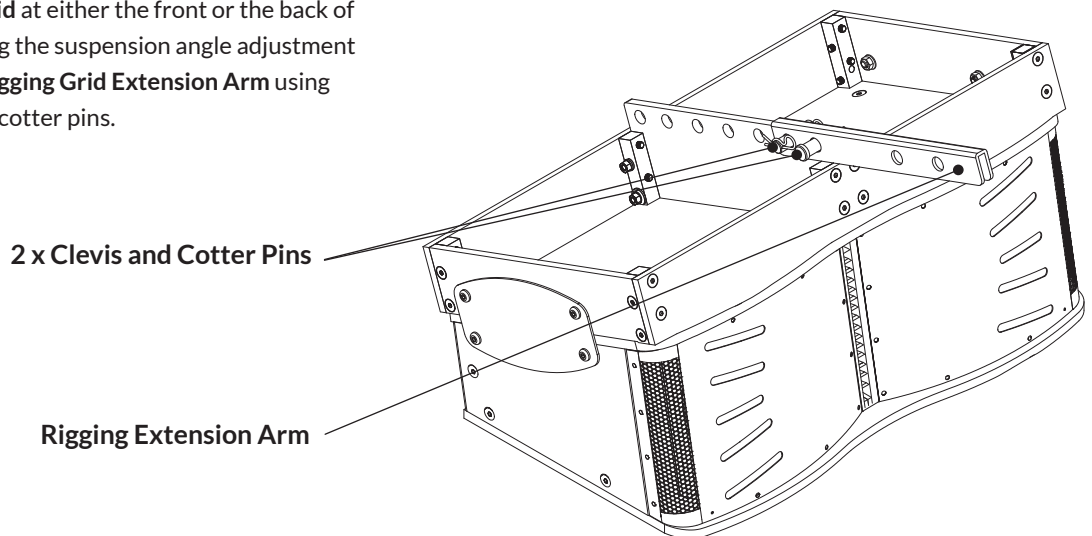

## 2. Applications and Deployment

### 2.4 Suspending CCA10i-BA Loudspeaker Arrays



**WARNING:** Consult a professional mechanical or structural engineer, licensed in the jurisdiction of the sound system installation, to review, verify, and approve all attachments to the building or structure. Employ the services of a certified, professional rigger for hoisting, positioning and rigging the equipment to the supporting structure. Improper suspension can lead to serious damage, injury, or death.

**NEVER SUSPEND LOUDSPEAKERS DIRECTLY ABOVE THE AUDIENCE**



The tables below show the individual CCA10i-BA component weights and the total weights for arrays up to the maximum recommended configuration of four CCA10i - BA loudspeakers. Deploying loudspeakers that exceed the maximum configuration can lead to serious damage, injury, or death. Blaze Audio has tested the configurations below for safety. Please note that the structure from which CCA10i-BA loudspeaker arrays are suspended must be able to support that total weight.

CCA10i-BA Individual Component Weights	
CCA10i-BA Loudspeaker	83 lbs (37.65 kg)
Rigging Plate	1.6 lbs (0.726 kg)
Rigging Grid (Aluminium)	32 lbs (14.5 kg)
Rigging Grid Extension Arm	7.2lbs (3.26kg)

Total CCA10i-BA Array Weights	
Number of Suspended CCA10i-BA	Array Weight
1	118.2 lbs (53.61 kg)
2	204.4 lbs (92.71 kg)
3	291 lbs (132 kg)
4	377.2 lbs (171.1 kg)



**WARNING:** All CCA10i-BA rigging and rigging accessories are rated for a 10:1 load. Structural suspension supports must also be rated for a 10:1 load.

# 3. Connection and Amplification

## 3.1 CCA10i-BA Input Connections

The CCA10i-BA is fitted with two Neutrik NL4 Speakon sockets on its rear panel. One socket is for input and the second is for pass-through. The “Input” is used for connection directly to the Blaze PowerZone Connect 3004 Amplifier and the “Link” can be used to connect in parallel to a second CCA10i-BA. Both Neutrik sockets are wired in a bi-amp configuration and use all four pins. The pin connections are listed in the table below.

### 3.1.1 CCA10i-BA Connections

The CCA10i-BA loudspeaker connection panel carries two, four-pole Neutrik Speakon sockets. An **INPUT** socket and a **LINK** output socket. Connect the **INPUT** socket to a pair of Blaze PowerZone Connect 3004 amplifier outputs. Optionally connect the **LINK** socket to the **INPUT** socket of a second CCA10i-BA loudspeaker.

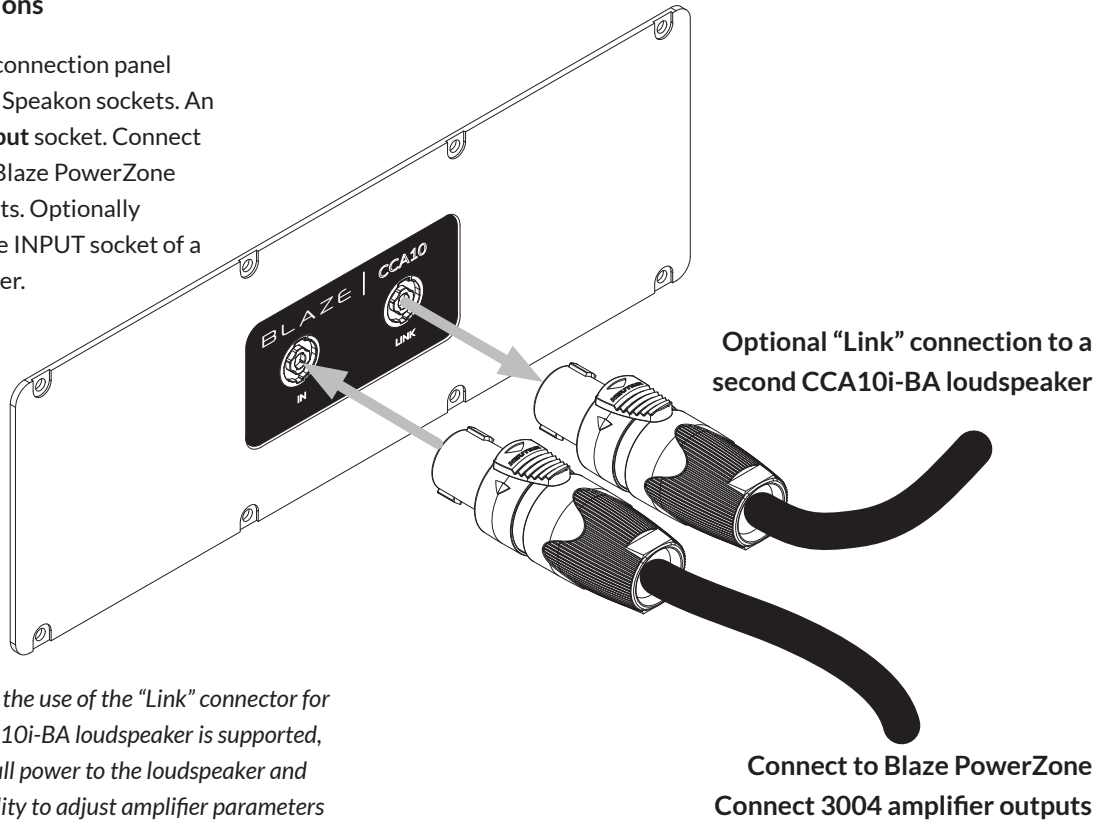

**NOTE:** While the use of the “Link” connector for a second CCA10i-BA loudspeaker is supported, to maintain full power to the loudspeaker and retain the ability to adjust amplifier parameters for loudspeakers independently, Blaze does not normally recommend this mode of use.

### 3.1.2 CCA10i-BA Connections Signal Routing

CCA10i-BA loudspeaker connections are intended for bi-amp configuration where each loudspeaker is powered by two amplifier channels – one for the twin bass drivers and one for the horn loaded compression mid/high frequency driver. The four-pole INPUT and LINK sockets are wired to enable this connection scheme as indicated in the following table and diagram.

CCA10i-BA Socket Connections	
Signal Routing	Connection Pin
LF (-)	1 (-)
LF (+)	1 (+)
HF (-)	2 (-)
HF (+)	2 (+)

### Neutrik Speakon NL4 Pins

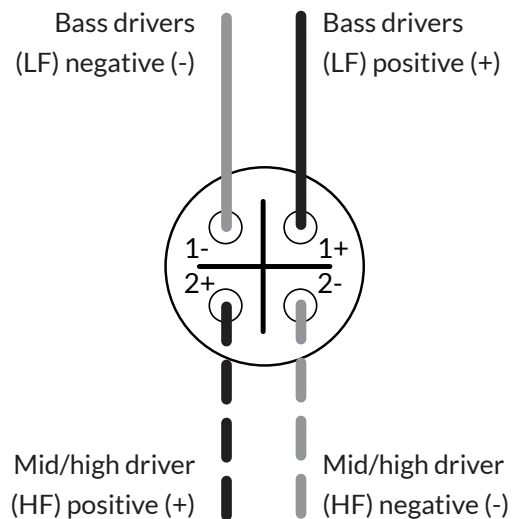

# 3. Connection and Amplification

## 3.1.3 CCA10i-BA Amplifier Connections

CCA10i-BA loudspeakers are intended to be paired with the Blaze PowerZone Connect 3004 amplifier. The PowerZone Connect 3004 incorporates the DSP equalisation facilities required to optimise the loudspeaker's acoustic performance. The PowerZone Connect 3004 is a four channel power amplifier able to drive two CCA10i-BA loudspeakers. It is not recommended that more than two CCA10i-BA loudspeakers are connected to a single PowerZone Connect 3004 amplifier.

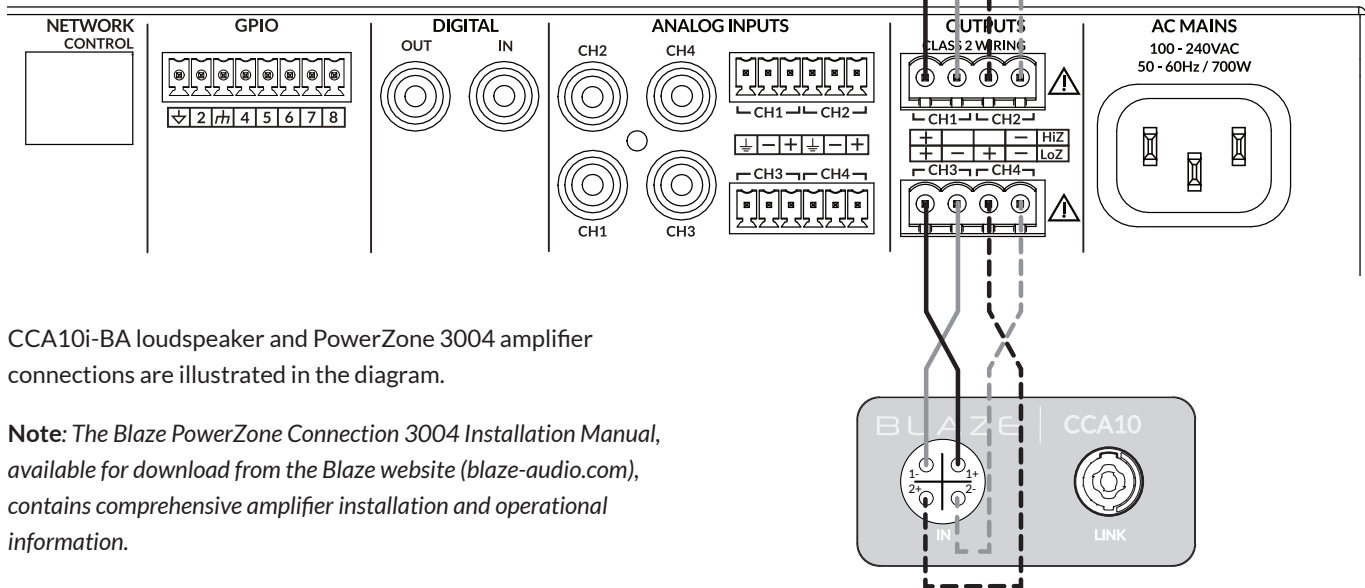

CCA10i-BA loudspeaker and PowerZone 3004 amplifier connections are illustrated in the diagram.

**Note:** The *Blaze PowerZone Connection 3004 Installation Manual*, available for download from the *Blaze website (blaze-audio.com)*, contains comprehensive amplifier installation and operational information.

# 3. Connection and Amplification

## 3.2 PowerZone Connect Amplifier Equalization Profiles

The Blaze PowerZone Connect 3004 amplifier incorporates DSP based loudspeaker equalization, accessed via a web page interface, that enables preconfigured filter and equalization presets to be applied to its speaker outputs. A preset for CCA10i-BA loudspeakers is available for download from the Blaze website and must be used for correct speaker performance. The procedure for downloading and applying speaker presets is described in the following paragraphs.

### 3.2.1 PowerZone Control Network Connection

In order to install the CCA10i-BA speaker preset files, the PowerZone Connect 3004 amplifier requires either a wired or wireless connection via a TCP/IP network, or to connect via its own wireless access point, to a computer or mobile device from which speaker preset files can be uploaded. Internet access for speaker preset file download is also required.

**Note:** The PowerZone Connect 3004 amplifier Quick Start Guide and Installation Manual documents cover network connection and can be downloaded from the Blaze website: <https://blaze-audio.com/support/#Manuals>

### 3.2.2 Speaker Preset Download and Application

Follow the steps below to download and apply the appropriate CCA10i-BA speaker preset to each amplifier output.

**Step 1.** Using a computer or mobile device, visit the Blaze website ([blaze-audio.com/products/speakers/cca10/](https://blaze-audio.com/products/speakers/cca10/)) and select the speaker preset files for download.

**NOTE:** The speaker preset files will download in a compressed .zip archive format. Expand the .zip archive and store the files in an appropriate location on the download device.

**Step 2.** On the computer or mobile device, navigate to the PowerZone Connect 3004 amplifier web interface and select the **Output** tab.

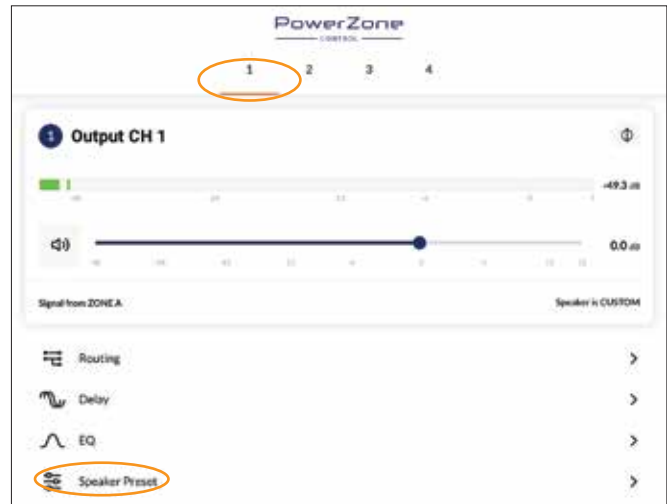

**Step 3.** From the **Output** page select the **Output 1** tab at the top of the display and then select the **Speaker Preset** menu option.



**NOTE:** The exact appearance and layout of the amplifier web interface may vary slightly depending on the device and browser in use.

### 3. Connection and Amplification



**Step 4.** Selecting **IMPORT PRESET FROM FILE** will open the **Speaker Preset Import** pop-up box that provides the option to choose a preset file.

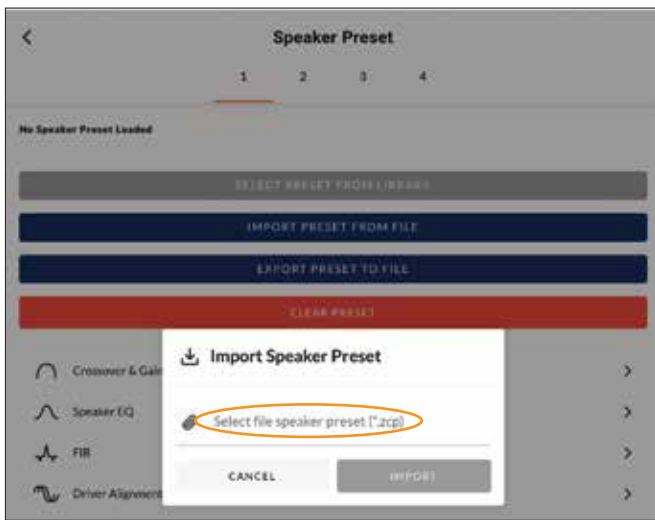

**Step 5.** Browse the download device for the files downloaded in **Step 1** and select the file named: **CCA10\_Bass\_PreSet\_Locked\_V1.2.zcp**  
Select **IMPORT**.



**Step 6.** The speaker preset file will now be applied to amplifier **Output 1**.

**Step 7.** With the appropriate speaker preset file (CCA10\_Bass\_PreSet\_Locked\_V1.2.zcp) applied to amplifier Output 1, repeat **Step 2** to **Step 6** for the three remaining amplifier outputs. The appropriate speaker preset files for each output are:

**Output 2:** CCA10\_High\_PreSet\_Locked\_V1.2.zcp

**Output 3:** CCA10\_Bass\_PreSet\_Locked\_V1.2.zcp

**Output 4:** CCA10\_High\_s\_Locked\_V1.2.zcp

**NOTE:** Amplifier outputs are selected from the numbered tabs at the top of the amplifier interface Output page.



**IMPORTANT:** It is vital for the correct operation of the CCA10i-BA loudspeaker that the correct speaker preset file is applied to each amplifier output and that the speakers are connected as described in Section 3 of this manual.

# 4. Technical Information

## 4.1 CCA10i-BA Specifications

4.1.1 System Performance	
Frequency Response (-3dB) *	52Hz - 18kHz
Frequency Response (-10dB) *	45Hz - 18kHz
Recommended High-Pass	48 Hz - w/ minimum 24 dB / Butterworth Filter
Horizontal Nominal Dispersion (-6dB)	160°
Vertical Nominal Dispersion (-6dB)	20°
Recommended Crossover Frequency	420Hz (acoustic, active, external DSP)
Low-Frequency Drivers	Dual 10" w 2.5" Voice Coil
Mid/High-Frequency Drivers	Coaxial: 4" mid driver, 2.55" hf tweeter
Long Term Power Handling (Low Freq.) **	600 W (2400 W peak)
Long Term Power Handling (High Freq.) **	110 W (440 W peak)
Bi-Amp Impedance (Low Freq.)	4 ohms
Bi-Amp Impedance (High Freq.)	8 ohms
Pressure Sensitivity @ 1W/1m (Low Freq.) ***	101 dB
Pressure Sensitivity @ 1W/1m (High Freq.) ***	111.4 dB
Bi-Amp Max SPL @ 1W/1m	131 dB SPL

### NOTES:

\* Frequency response and range measured on-axis with recommended active EQ in an anechoic environment.

\*\* Power handling tested using pink noise filtered to meet IEC 268-5, 6 dB crest factor, 100 hours (approx 4 days), with recommended active EQ.

\*\*\* Sensitivity measured in free field (no boundary-loading gain) with recommended active EQ, referenced to 1W/1m. Maximum SPL calculated from sensitivity and power handling specifications, exclusive of power compression (100Hz-10KHz).

4.1.2 Physical Characteristics	
Enclosure Material	Baltic birch plywood, engineered plastics, and aluminum frame.
Finish	Two-part spray catalyzed Polyurea coating on plywood.
Grille Material	14-gauge (2mm) perforated steel, powder-coated finish, black.
Environmental	Indoor use only.
Connectors/Bi-Amp	Two (2) parallel-wired NL4 Neutrik® Speakon® connectors.
Suspension/Mounting	Install side rigging, optional array frame accessories.
Dimensions (HxWxD)	13.23" x 32.33" x 18.25" (336.14 x 821.21 x 463.68mm)
Net Weight	83lbs / 37.65kg
Shipping Weight	88lbs / 39.91kg

# 4. Technical Information

## 4.2 CCA10i-BA Mechanical Drawings

### 4.2.1 CCA10i-BA Loudspeaker Dimensions

