

**GoWISEUSA®**

# MULTI AIR FRYER **VIBE**

## USER MANUAL

Model No.: GW77722, GW77723



Please read through this manual carefully before use

**⚠ IMPORTANT SAFEGUARDS AND TIPS**

[WWW.GOWISEUSA.COM](http://WWW.GOWISEUSA.COM)

# THANK YOU FOR YOUR PURCHASE!

---

## Join

the GoWISE Community on Facebook, Instagram, Twitter, and Pinterest for updates, tips, and great deals!



## Explore

our recipes at [www.gowiseproducts.com/blogs/recipes](http://www.gowiseproducts.com/blogs/recipes)



## Contact Our Customer Care Team

855-233-9199

[support@gowiseusa.com](mailto:support@gowiseusa.com)

Live Chat at [gowiseusa.com](http://gowiseusa.com)

**M-F** 8:30am - 4:00pm MST



## Register Your Product

[www.gowiseproducts.com/apps/product-registration](http://www.gowiseproducts.com/apps/product-registration)

(Normally the serial number is on the bottom of the product. Please check there first.)



## Specifications

Voltage: 120V, 60Hz

Watts: 1700W

Capacity: 11.6 Qt

Temp. Range: 80°F-400°F



# TABLE OF CONTENTS

---

<b>Register Your Product.....</b>	<b>2</b>
<b>Specifications.....</b>	<b>2</b>
<b>Important Safeguards.....</b>	<b>4</b>
Important.....	6
Electromagnetic Fields.....	6
<b>Parts and Accessories.....</b>	<b>7</b>
<b>Control Display.....</b>	<b>8</b>
<b>Set Up and Using Multi Air Fryer.....</b>	<b>10</b>
Before First Use.....	10
Removable Door.....	10
Using Your Accessories.....	11
<b>Cooking Guide.....</b>	<b>14</b>
Cooking Chart.....	14
Internal Temperature Chart.....	15
Tips.....	15
<b>Trussing a Whole Chicken.....</b>	<b>16</b>
<b>Rotisserie Roast a Whole Chicken.....</b>	<b>18</b>
<b>Cleaning Your Air Fryer.....</b>	<b>19</b>
<b>Troubleshooting &amp; Error Codes.....</b>	<b>20</b>
<b>Warranty.....</b>	<b>22</b>

# IMPORTANT SAFEGUARDS

---

## HOUSEHOLD USE ONLY • READ ALL INSTRUCTIONS BEFORE USE

- 1. NEVER IMMERSE** the main unit housing in water, as it contains electrical components and heating elements. Do not rinse under the tap.
- 2. TO AVOID ELECTRIC SHOCK, DO NOT** put liquid of any kind into the main unit housing containing the electrical components.
- 3.** This appliance has a polarized plug (one prong is wider than the other). This plug is intended to fit into a polarized outlet only one way. **TO AVOID ELECTRIC SHOCK, DO NOT** force the plug into the outlet if it does not fit. If the plug does not fit fully into the outlet, reverse the plug. If it still does not fit, contact a qualified electrician. **DO NOT ATTEMPT** to modify the plug in any way.
- 4. ALWAYS** make sure that the plug is inserted into the wall socket properly. **THIS APPLIANCE CAN ONLY OPERATE ON A DEDICATED OUTLET.**
- 5.** To prevent food being in contact with the heating element, **DO NOT OVERFILL** any of the cooking trays.
- 6. DO NOT COVER OR BLOCK** the air intake or outlet vent while the **GoWISE USA Multi Air Fryer** is in operation. Doing so prevents even cooking and may damage the unit or cause it to overheat.
- 7. NEVER POUR** oil into the square accessory basket (sold separately). This could result in fire or personal injury.
- 8.** While cooking, the internal temperature of the unit reaches several hundred degrees Fahrenheit. **TO AVOID PERSONAL INJURY,** never place hands inside the unit unless it has thoroughly cooled.
- 9.** This appliance is **NOT INTENDED FOR USE** by persons with reduced physical, sensory, or mental capabilities or persons with a lack of experience and knowledge unless they are **UNDER THE SUPERVISION** of a responsible person or have been giving proper instruction to use the appliance.
- 10.** This appliance is **NOT INTENDED FOR USE** by children.
- 11.** When cooking, **DO NOT PLACE** the appliance against a wall or other appliances. Leave at least five inches of free space along the back, sides, and above the appliance. Do not place anything on top of the appliance.
- 12. DO NOT USE** this unit if the plug, the power cord, or the appliance itself is damaged in any way.
- 13. DO NOT PLACE** the unit on stove top surfaces.
- 14.** If the power cord is damaged, **YOU MUST HAVE IT REPLACED** by the manufacturer, its service agent, or similarly qualified person to avoid hazard.
- 15.** Keep the appliance and its power cord **OUT OF THE REACH** of children when it is in operation or during the cooling process.

# IMPORTANT SAFEGUARDS

---

## HOUSEHOLD USE ONLY • READ ALL INSTRUCTIONS BEFORE USE

- 16. KEEP THE POWER CORD AWAY** from hot surfaces. **DO NOT PLUG** in the power cord or operate the unit controls with wet hands.
- 17. NEVER CONNECT** this appliance to an external timer switch or separate remote control system.
- 18. NEVER USE** this appliance with an extension cord of any kind.
- 19. DO NOT OPERATE** the appliance on or near flammable materials, such as tablecloths and curtains.
- 20. DO NOT USE** the **GoWISE USA Multi Air Fryer** for any purpose other than described in this manual.
- 21. NEVER OPERATE** the appliance unattended.
- 22. KEEP YOUR HANDS AND FACE** at a safe distance from the air outlet vent, as hot air is released through it while in operation.
- 23.** Avoid the vent while removing the square accessory basket from the appliance. (ACCESSORY BASKET SOLD SEPARATELY)
- 24.** The unit's outer surfaces may become hot during use. **USE OVEN MITTS** or use the rotisserie tong when handling hot components. Always use oven mitts when handling hot objects and surfaces.
- 25.** If the unit emits black smoke, **UNPLUG IMMEDIATELY** and wait for smoking to stop before removing oven contents.
- 26.** When the cooking time is completed, the heating element will shut down, but the fan **WILL CONTINUE RUNNING** for at least 20 seconds to cool down the unit.
- 27. ALWAYS** operate the appliance on a horizontal surface that is level, stable, and noncombustible.
- 28.** If the **GoWISE USA Multi Air Fryer** is used improperly, for professional or semi-professional purposes, or if it is not used according to the instructions in this user manual, the warranty becomes invalid, and the manufacturer will not be held liable for damages.
- 29. ALWAYS** unplug the appliance after every use.
- 30.** Let the appliance cool down for at least 30 minutes before handling, cleaning, or storing.
- 31. MAKE SURE** the ingredients prepared in this unit come out cooked to golden-yellow color rather than dark brown. Remove burnt remnants.
- 32.** This appliance is intended for normal household use only. It is not intended for use in commercial or retail environments.
- 33.** If the inner temperature control system fails, the oven's overheating protection system will activate, and the oven will not function. If this happens, unplug the power cord and wait for the unit to cool down completely before trying to cook again.

# IMPORTANT SAFEGUARDS

---

## HOUSEHOLD USE ONLY • READ ALL INSTRUCTIONS BEFORE USE

**34.** Please note that this unit is constantly emitting heat through the air vents, the unit must be placed on a heat resistant surface. It is the end-user's responsibility to verify the heat capacity of their countertops. We recommend using a silicone pad or spare, non-artificial tile to protect your countertops from heat damage. **The care and use of countertops is the responsibility of the end-user.**

### **Important**

Before initial use and after subsequent use, hand wash all included accessories. Wipe the outside and inside of the Unit with a warm moist cloth and mild detergent. Preheat the Unit for a few minutes to burn off any residue.

### **Electromagnetic Fields**

This appliance complies with all standards regarding electromagnetic fields. According to the instructions in this manual, the appliance is safe to use based on scientific evidence available today if handled properly.

**SAVE THESE  
INSTRUCTIONS**

# PARTS AND ACCESSORIES

## PARTS

1. Control Panel
2. Unit Housing
3. Internal Heating Compartment
4. Removable Door
5. Air Outlet Vent
6. Power Cord + Plug

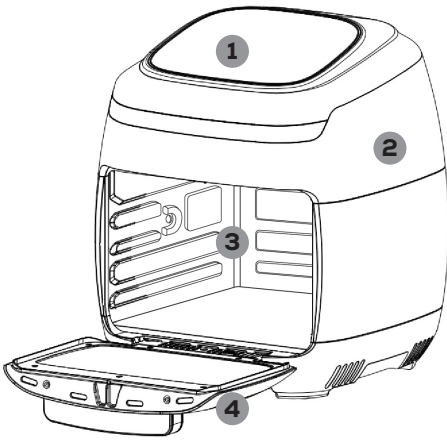

## ACCESSORIES

- a. Rotisserie Tong
- b. Rotisserie Rod & Forks
- c. Rotisserie Skewers
- d. Rotisserie Cage
- e. Mesh Tray X3
- f. Drip Tray

**NOTE:** Rotisserie Forks and Skewers share one (1) rod.

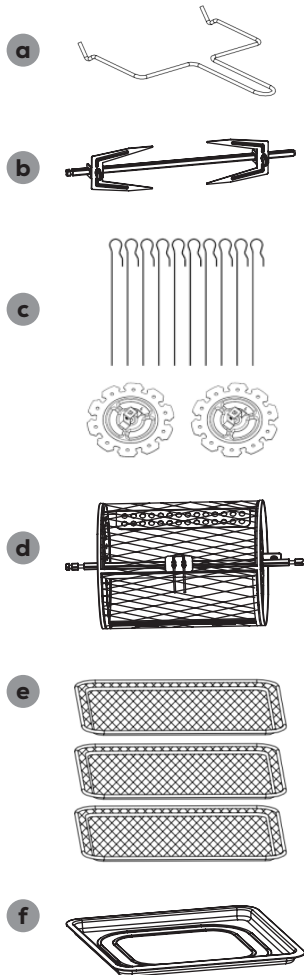

# CONTROL DISPLAY

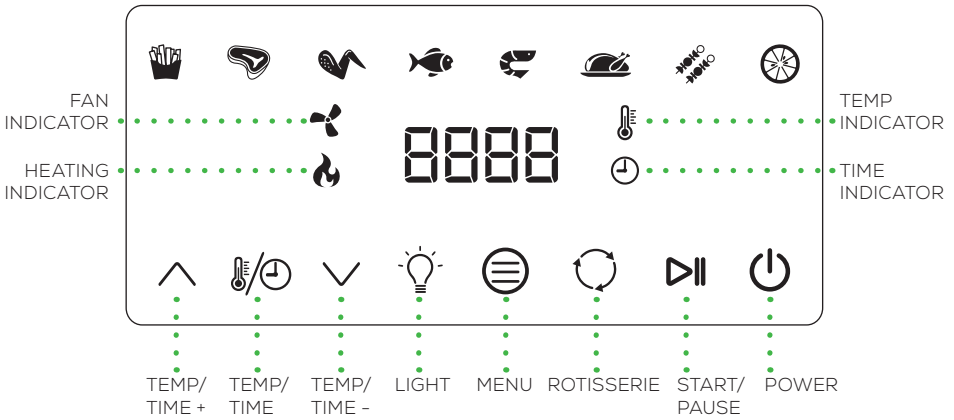

## BUTTONS

**POWER:** Powers the unit on and off

**START/PAUSE:** Starts and stops the cooking process

**ROTISSERIE:** Activates the Rotisserie function

**MENU:** Cycles through preset options

**LIGHT:** Turns the internal cooking light on or off

**TEMP/TIME:** Adjusts temperature and time of cooking presets

**UP & DOWN arrows:** Increases or decreases TEMP & TIME

## PRESETS DEFAULT TIME&TEMP

**Fries:** 20 minutes at 400°F

**Steak:** 20 minutes at 370°F

**Wings:** 35 minutes at 370°F

**Fish:** 18 minutes at 360°F

**Shrimp:** 10 minutes at 320°F

**Roast Chicken\*:** 35 minutes at 400°F

**Kebab Skewers:** 10 minutes at 400°F

**Dehydrate:** 4 hours at 130°F

\*Cooking time of a whole roasted chicken may vary depending on weight. Use a meat thermometer to check the internal temperature as per the chart on page 15.









## WARNING

Never use a cooking vessel filled with cooking oil or any other liquid with this Unit! Fire Hazard or personal injury could result.

# CONTROL DISPLAY

---

## USING THE DIGITAL CONTROLS

1. Once the unit is plugged in, the display lights will flash once with a single chime/beep. The POWER button will remain illuminated.
  2. Tap the POWER button to illuminate the basic menu options.
  3. Adjust the time and temperature by pressing the TEMP/TIME button to toggle between time and temperature and use the  or  arrows to increase or decrease as needed.
  4. OR, select a preset by pressing the MENU button repeatedly until desired cooking preset is reached.
  5. To adjust a preset's temperature or time, press the TEMP/TIME button to toggle between time and temperature, and use the  or  arrows buttons to increase or decrease as needed.
- NOTE:** Hold down the arrows to increase or decrease the time and temperature at a faster rate.
- If using a Rotisserie accessory, make sure the Rotisserie function is activated by pressing the ROTISSERIE button on the Digital Display before starting the cooking process.
  - Press the LIGHT button to turn the oven light on and off any time throughout the cooking process.
  - The  and  icons will display to indicate whether the fan is running, and if the oven is heating. When a cooking cycle completes, the  icon will be off, but the fan may still be running. During the dehydrate setting, the heat will periodically shut off to maintain the correct temperature and will be indicated by the  icon.

# SET UP AND USING MULTI AIR FRYER

## BEFORE FIRST USE

1. Unbox the Unit and place on a countertop or flat surface away from any water source and near a polarized outlet. Before plugging in the Unit, remove accessories from the Internal Heating Compartment. Unwrap accessories.
2. Rinse the accessories with warm water and dry thoroughly. Place the Drip Tray at the bottom of the Internal Heating Compartment and close the door.
3. Plug in the Unit. Press the POWER button to turn the unit on. Press the TEMP/TIME button and use the ^ and v arrows to adjust temp and time settings to 5 minutes at 350°F.  
**NOTE:** This process will burn off any remaining residue left from the manufacturer. There may be a slight burning smell but, will dissipate after a few minutes.
4. Your new GoWISE USA Multi Air Fryer Vibe is now ready for use!

## REMOVABLE DOOR

The door can be removed for cleaning. **DO NOT** put the door in the dishwasher, as water may seep into the dual pane glass. Instead use a sponge or cloth with a dash of dish soap to remove grease and mess. Gently rinse with warm water and dry with a soft cloth.

**To Remove:** The door opens to about 70°. Push the white button down and move in the direction of the arrow (as shown below), then pull the door down to force it apart.

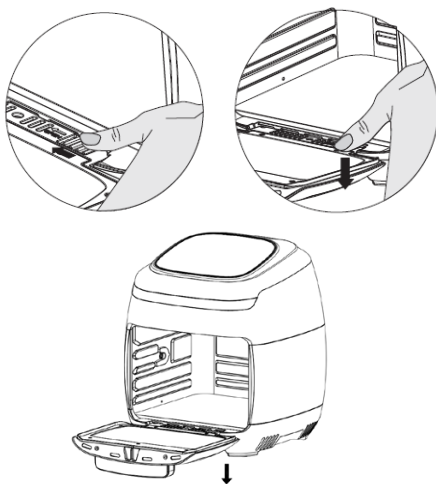

**To Insert:** Align the shaft on the door with the hole on the base and insert the door at the angle of the below figure.

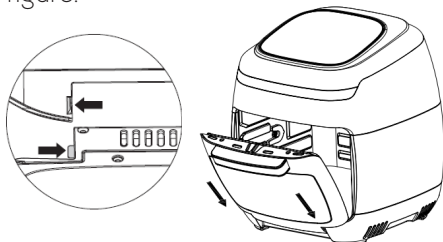

# SET UP AND USING MULTI AIR FRYER

## USING YOUR ACCESSORIES

### Drip Tray

The drip tray should always be kept in the unit when cooking for easy cleanup. To use, simply slide the tray in the bottom-most rack and cook. The surface is an FDA-approved non-stick material. Be sure to use a non-abrasive sponge to clean.

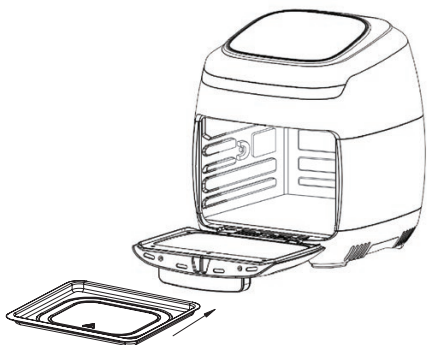

### Mesh Trays

The mesh trays are great for dehydrating, but also can be used for crispy snacks or reheating pizza. If using to roast or air fry fresh meats, it is recommended to brush a little bit of oil on the mesh to prevent sticking. To use, simply slide mesh trays into any of the 4 rack levels.

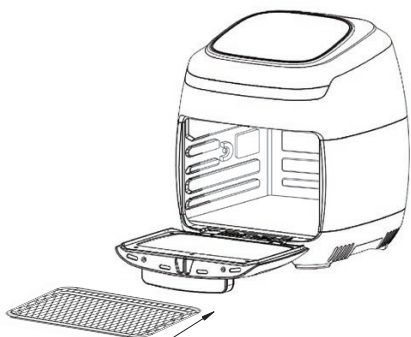

### Rotisserie Cage

Great for fries, roasted nuts, and other snacks. Fill the basket and use the rotisserie tong to place the basket into the unit.

**How to use:** Open the rotisserie cage door and add your ingredients. Close the cage door and insert into the oven using the rotisserie tong.

**NOTE:** Be sure to use oven mitts when removing the rotisserie cage after cooking.

### Rotisserie Rod & Forks

Make your own rotisserie chicken, Cornish game hen, roasted pork loin and more using the rotisserie rod and forks. Keep in mind the maximum weight capacity for the rotisserie is **4.5 pounds**. When cooking a whole chicken or hen, you may need to truss it first. Instructions for trussing a chicken can be found on page 18 of this manual.

**How to use:** Force the rotisserie rod lengthwise through the center of the meat. Slide forks onto the rod from either end and into the meat. Lock in place by tightening the thumb screws. Use the rotisserie tong to place the rod into the rotisserie position in the heating compartment.

**NOTE:** Make sure the roast or chicken is not too large and rotates freely within the unit.

# SET UP AND USING MULTI AIR FRYER

## USING YOUR ACCESSORIES

**Rotisserie Skewers:** Use for cooking Kebabs.

1. Place the two skewer racks at each end of the rotisserie rod. Make sure thumb bolts are on the outer side of the rotisserie rod.
2. Slightly tighten the thumb bolts. Do not over tighten as you may need to adjust the tightness after inserting skewers.
3. Carefully poke skewers through food.
4. Guide the sharp end of the skewer through an open hole on the skewer rack.
5. Slide the rounded skewer handle into an open slot on the opposite skewer rack. You may need to twist and squeeze the rounded skewer handle until its positioned properly in the slot.
6. Repeat steps 3-5 in a uniform manner around the skewer rack. Make sure skewers are evenly spaced.
7. Tighten thumb bolts to make sure they are securely in place.
8. Use caution when inserting Rotisserie Skewers into the Unit to avoid being poked by the Skewer tips.
9. Open the door. Insert one end of the Rotisserie Rod into the Rotisserie Socket first then, set the opposite end into the Rotisserie slot. Do not force the rod into the socket; rotate until the rod slips in easily.

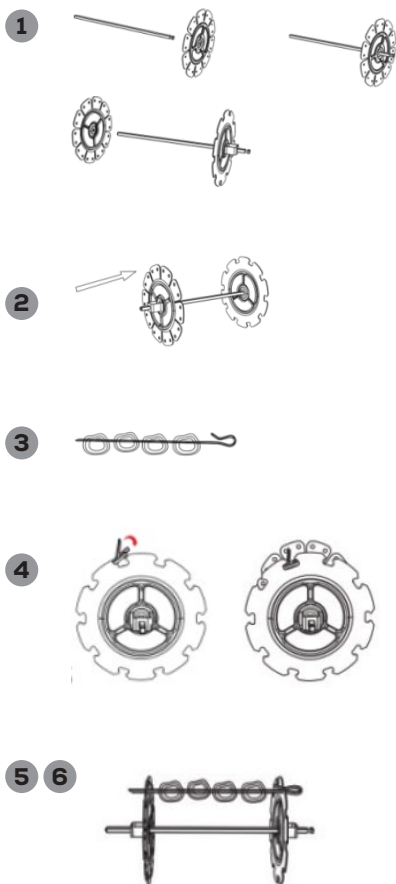

# SET UP AND USING MULTI AIR FRYER

## USING YOUR ACCESSORIES

### Removing Rotisserie Rod, Rotisserie Skewers, and Rotisserie Cage from Unit

1. Open the door.
2. While wearing oven mitts on both hands and using the Rotisserie Tong, hook the bottom left and right sides of the Rotisserie Rod, in the gaps of the rod and carefully lift the rod out of the resting slot on the right side of the compartment – carefully pull the rod out of the Rotisserie socket and remove from the unit.

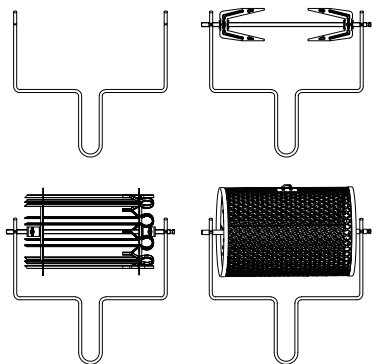

**NOTE:** Contents will be hot and can easily burn – use caution not to let scalding meat juices or oils from falling on the skin by holding a catch tray or plate under the rotisserie contents.

### NOTES:

- The GoWISE USA Multi Air Fryer Vibe will only begin heating once the door is completely closed.
- The door can be opened during the cooking process – the Unit will stop heating automatically until the door is closed again. The fan will also stop while the door remains open. If the door remains open for 6 minutes, the Unit will shut down.
- **TO STOP COOKING** after the Unit has already started working, hold the power button for 1-2 seconds.  
**NOTE:** If the Unit has been running for any period the heating element will be HOT, the fan will continue to blow to cool the heating element before shutting down completely. However, the Unit will have stopped heating.

**CAUTION!** Contents and cooking accessories will be extremely hot after every use. To prevent personal injury, always use oven mitts to remove contents and always wait until the Unit has cooled sufficiently before touching or cleaning any area of the Internal Heating Compartment of the Air Fryer.

# COOKING GUIDE

The chart here is a guide that will help you with setting the time and temperature for certain ingredients (NOTE: Please keep in mind that because ingredients differ in size, shape, brand, and origin, we cannot guarantee that this is the best setting for the ingredients you have).

Food	Time	Temperature	Flip	Tips
<b>Potatoes &amp; Fries</b>				
Thin Frozen Fries	9-16 min	400°F	/	Add 1/2 Tbsp of Oil
Thick Frozen Fries	11-20 min	400°F	/	
Homemade Fries	16-20 min	400°F	/	
Homemade Potato Wedges	18-22 min	360°F	/	
Homemade Potato Cubes	12-18 min	360°F	/	
Falafel	15 min	360°F	/	
Potato Gratin	15-18 min	400°F	/	
<b>Meat &amp; Poultry</b>				
Steak	8-12 min	360°F	Flip	Line with tin foil
Pork Chops	10-14 min	360°F	Flip	
Hamburger	7-14 min	360°F	Flip	
Sausage Roll	13-15 min	400°F	Flip	
Drumsticks	18-22 min	360°F	Flip	
Chicken Breast	10-15 min	360°F	Flip	
<b>Snacks</b>				
Spring Rolls	8-10 min	400°F	Flip	/
Frozen Chicken Nuggets	6-10 min	400°F	Flip	
Frozen Fish Sticks	6-10 min	400°F	Flip	
Frozen Mozzarella Sticks	8-10 min	360°F	Flip	
Stuffed Vegetables	10 min	320°F	Flip	
<b>Baking</b>				
Cake	20-25 min	320°F	/	Use baking tin
Quiche	20-22 min	360°F	/	
Muffins	15-18 min	400°F	/	
Sweet Snacks	20 min	320°F	/	

# COOKING GUIDE

## INTERNAL TEMPERATURE CHART

\*This chart should be used to check the temperature of cooked meats. Always review USDA Food Safety Standards.

Food	Type	Internal Temperature
Beef + Veal	Ground	160°F (70°C)
	Steaks, Roasts: medium	160°F (70°C)
	Steaks, Roasts: rare	145°F (63°C)
Chicken + Turkey	Breasts	165°F (75°C)
	Ground, Stuffed	165°F (75°C)
	Whole bird, legs, thighs, wings	165°F (75°C)
Fish + Shellfish	Any type	145°F (63°C)
Lamb	Ground	160°F (70°C)
	Steaks, Roasts: medium	160°F (70°C)
	Steaks, Roast: rare	145°F (63°C)
Pork	Chops, Ground, Ribs, Roasts	160°F (70°C)
	Fully cooked Ham	140°F (60°C)

## TIPS

- Cooking times may vary based on the quantity and thickness of the ingredients.
- Try flipping ingredients mid-way through the cooking process for an even, crispy texture.
- Adding a minimal amount of oil to fresh potatoes will give it a crispier result.
- Avoid cooking extremely oily ingredients in the air fryer.
- Anything that can be prepared in a traditional oven can also be cooked in the air fryer.
- Pre-made or store bought dough requires a shorter cooking time than homemade dough.
- When baking a cake, quiche or other recipes using a filling, cook in a tin or oven safe pan.
- When using the rotisserie, make sure the contents are secure and do not flop loosely.
- Do not rotisserie foods that are too heavy! 4.5 lbs max.
- For the best rotisserie experience, always truss meats, chicken, and roasts with butcher's twine.

# TRUSSING A WHOLE CHICKEN

---

1. Finding the right size chicken  
– be careful not use a chicken exceeding the 4.5 lbs max.
2. After preparing, i.e., seasoning the chicken, truss the chicken using butcher's twine.
  - a. Place the chicken on its back with the legs facing toward you.
  - b. Slide a piece of twine under the back of the chicken between the wings and the thighs.
  - c. Pull both ends of the twine up under the chicken's armpits, then pull them over the wings.
  - d. Cross the string around the top of the breast, making sure the skin is secure.
  - e. Bring the ends of the twine back toward you, running them along the sides of the breast above the wings and thighs.

a



b



c



d



e



# TRUSSING A WHOLE CHICKEN

- f. Cross the ends of the twine, pulling tightly up and under the crown of the bird.
- g. Loop the ends of the string under the legs, then over the top of the legs. Cross and tighten. The thighs should pop up a little.
- h. Flip the bird onto its belly and finish by tying the strings in a knot around the tail. Snip off the ends.



f

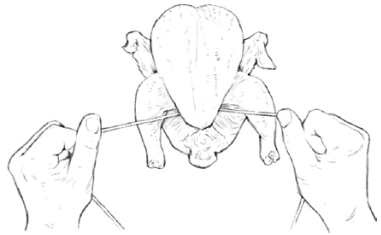

g

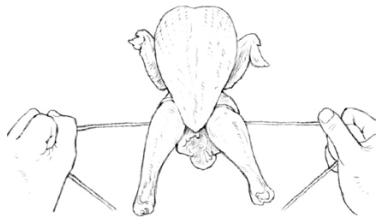
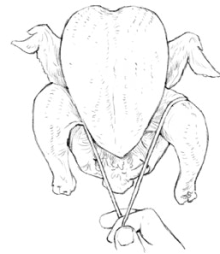

h



# ROTISSERIE ROAST A WHOLE CHICKEN

## Using the Rotisserie Rod to Roast a Whole Chicken

1. After the chicken is trussed, carefully maneuver the Rotisserie Rod through the chicken from the neck to the legs.
2. Slide the Rotisserie Forks on both sides of the Rotisserie Rod piercing the chicken; making sure to secure the chicken in place.
3. Using the Thumb Bolts, lightly tighten the Rotisserie Forks into place – Do not over tighten as removing Rotisserie Forks may become difficult after cooking.
4. Open the door. Insert one end of the Rotisserie Rod into the Rotisserie Socket first then, set the opposite end into the Rotisserie slot. Do not force the rod into the socket, rotate until the rod slips in easily.
5. Turn the Unit on by pressing POWER button and select the Roast Chicken Preset by cycling through MENU.
6. Press ROTISSERIE button on the Digital Display to engage the rotation functionality of the unit.
7. The default cooking temperature and time for Rotisserie is 400°F for 35 min – if the chicken is not golden brown and crispy and the internal temperature is not 165°F, repeat the cooking cycle.
8. When the chicken is done cooking with the internal temperature of 165°F, remove the chicken using the Rotisserie Tong.
  - a. Open the door.
  - b. While using oven mitts on both hands and using the Rotisserie Tong, hook the bottom left and right sides of the Rotisserie Rod, in the gaps of the rod and carefully lift the rod out of the resting slot on the right side of the compartment – carefully pull the rod out of the Rotisserie socket and remove from the air fryer.

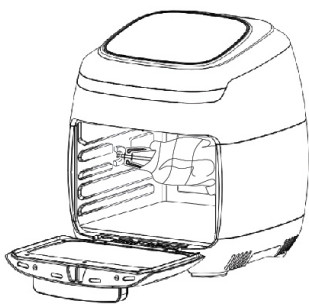
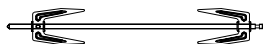

**NOTE:** Contents will be hot and can easily burn – use caution not to let scalding meat juices or oils from falling on the skin by holding a catch tray or plate under the rotisserie contents.

# CLEANING YOUR AIR FRYER

---

- 1.** Wait at least 30 minutes for the unit to cool down before cleaning.
- 2.** Remove the trays or accessories used and set aside.
- 3.** Using dish soap and a damp sponge, wipe out the inside of the air fryer. Use a damp paper towel or soft rag to wipe up the remaining soapy residue.
- 4.** Remove the door for easy cleaning. Refer to page 10 for instructions. Do not wash the door in the dishwasher. Use warm, soapy water and a sponge instead. Wipe dry with a soft kitchen towel.
- 5.** Scrubbing with soap and a sponge may be more effective to remove stuck-on food.
- 6.** Use a non-abrasive sponge to wash the non-stick drip tray. Soak for a few minutes first if mess does not slide off easily with the sponge.

# TROUBLESHOOTING & ERROR CODES

Problem	Possible Cause	Solution
The appliance is not turning on	The appliance is not plugged in	Plug the appliance into a grounded wall socket.
	You have not started the cooking cycle	Use the touch screen controls to select a preset or time & temp, then click the Start/Pause button.
My food isn't cooked all the way	The trays or basket have been overfilled	Use smaller batches to fry more evenly.
	The set temperature is too low	Increase the temperature using temperature controls.
My food is unevenly cooked	Ingredient positioning or overflow	Shake or flip ingredients midway through cooking. Swapping tray levels helps as well.
My food isn't crispy	Some snacks are crispier when traditionally fried	Use oven snacks or lightly brush some oil onto the snacks for a crispier result.
Trays are not sliding into the unit	Tray may not be positioned properly	Try inserting the tray from a different side.
White smoke comes out of the unit	It's normal for white smoke to appear when cooking greasy ingredients	When frying greasy ingredients, a large amount of oil will leak into the pan. The oil produces white smoke and the pan may heat up more than usual. This does not affect the appliance or end food result.
	The compartment or trays are still greasy	Clean the heating compartment and trays properly after each use.
The rotisserie is not turning	The rotisserie function is not selected	Press the ROTISSERIE button. It should be flashing to indicate the rotisserie function is activated.
	Too much weight for the rotisserie to spin	The weight should not exceed 4.5-5 pounds. Keep this in mind when shopping for a whole chicken or roast.
	Rotisserie rod not placed properly	Make sure the Rotisserie Rod is positioned correctly on each side of the compartment.

ERROR CODE	ISSUE
E1	Temperature sensor is not connected
E2	Short circuit of temperature sensor

If your GoWISE USA Multi Air Fryer displays any of these Error Codes, please contact Customer Care Team.

855-233-9199

support@gowiseusa.com

Live Chat at gowiseusa.com

**M-F** 8:30am - 4:00pm MST



## WARRANTY

---

GoWISE USA warrants all products against defects in materials and workmanship for **one (1) year** effective from the date of purchase.

GoWISE USA will replace any products that are found to be defective due to manufacturer flaws based on eligibility. Refunds issued by GoWISE USA must be purchased directly from GoWISE USA and are only available to the original purchaser within the first 30 days. We do not issue refunds for items bought by thirdparty retailers.

This warranty extends only to personal use and does not extend to products that has been used for commercial, rental or any other use this product was not intended for. There are no warranties other than the warranties expressly set forth with each product.

This warranty is non-transferrable. GoWISE USA is not responsible in any way for any damages, losses, or inconveniences caused by equipment failure by user negligence, abuse, or use noncompliant with the user manual or any additional safety, use, or warnings included in the product packaging and manual.

This warranty only covers purchases within the 48 contiguous States of United States of America. For purchases made outside the 48 contiguous states, such as, AK, HI, PR or Canada; upon receipt of a proven defect by video or picture, we will replace the unit under the 1-year warranty, however the replacement will only ship to a freight forwarder or an address within the 48 contiguous United States. The consumer is responsible for arranging shipment outside of the 48 contiguous states.

GoWISE USA assumes no liability for damage caused using this product other than for its intended use or as instructed in the user manual. Some states do not allow this exclusion or limitation of incidental or consequential losses, so the foregoing disclaimer may not apply to you. This warranty gives you specific legal rights and you may also have other rights which may vary from state to state.

ALL EXPRESSED AND IMPLIED WARRANTIES INCLUDING THE WARRANTY OF MERCHATIBILITY, ARE LIMITED TO THE PERIOD OF THE LIMITED WARRANTY.

**NOTE:** General Warranty excludes refurbished / auction items.

# WARRANTY

---

## Additional 60-Days Warranty

You can extend your 1-year warranty by an additional 60 days. Log onto [www.gowiseproducts.com/apps/ product-registration](http://www.gowiseproducts.com/apps/product-registration) and register your product within the first 14 days of your purchase for the extended warranty.

## DEFECTIVE PRODUCTS & RETURNS

If your product is defective within the 1-year warranty period, please email our Customer Care Team at [support@gowiseusa.com](mailto:support@gowiseusa.com). To expedite your issue, please provide at least 3 of the 4 items below:

1. Copy of the invoice, order information, or gift receipt showing the date of purchase
2. Serial number, usually found on a sticker located on the bottom on back of the unit
3. Picture or video of the issue or defect that you are experiencing
4. Shipping address information

## Authorized Retailers:

Amazon

GoWISE USA

WayFair

Houzz

Home Depot

etailz

MorningSave.com

Bed Bath & Beyond

Jet.com

Walmart.com

Macy's

# GoWISE USA®

WWW.GOWISEUSA.COM

855-233-9199

support@gowiseusa.com

Live Chat at gowiseusa.com

**M-F** 8:30am - 4:00pm MST

- To ensure the correct use of this appliance, read these instructions carefully and thoroughly.
- Please keep this manual for future reference.
- Thank you for purchasing this GoWISE USA Multi Air Fryer.

USE PROMO CODE: LIVEWISERAF

**10% OFF**

YOUR NEXT **GoWISE USA®** PURCHASE

