



Inverter

3000W 12V MANUAL

Wave Inverter Charger



SUPPORT

If you are experiencing technical problems and cannot find a solution in this manual, please contact ECO-WORTHY for further assistance.



·Call: 1-866 939 8222(US&CA)
+44 7553 406988(UK)
+49 6175 6514 999(DE)

·Web://www.eco-worthy.com/

·E-mail: customer.service@eco-worthy.com

Catalogue:

I . General Information	1
II . Introduction	5
III. Packing List	5
IV. Product Description.....	5
V . Installation	13
VI. Unit Operation	19
VII. Troubleshooting	34
VIII. Specification.....	35
IX. Warranty.....	37
VIII. Technical Support.....	39

Purpose

This manual describes the assembly, installation, operation and troubleshooting of this unit. Please read this manual carefully before installation and operation.

Scope

The manual provides safety and operating manual lines as well as information on installing and configuring the inverter-charger. It also provides information about troubleshooting the unit. It does not provide details about particular brands of batteries. You need to consult individual battery manufacturers for this information.

Please Keep This Manual For Future Reference

For safe and optimum performance, the Inverter-Charger must be used properly. Carefully read and follow all instructions and guidelines in this manual and give special attention to the CAUTION and WARNING statements.

Disclaimer

While every precaution has been taken to ensure the accuracy of the contents of this guide, we assume no responsibility for any errors or omissions. Eco-worthy reserves the rights to change specifications and product functionality without notice.





Important

Please be sure to read and save the entire manual before using your Sine wave Inverter-Charger. Misuse may result in damage to the unit and/or cause serious injury. Read manual in its entirety before using the unit and save manual for future reference.

IMPORTANT SAFETY INFORMATION

This section contains important safety information for the Sine wave Inverter Charger. Before using the unit, please read all instructions and cautionary markings provided with the unit, and all appropriate sections of this guide.

The Sine wave Inverter-Charger contains no user-serviceable parts. See Warranty section for how to handle product issues.

Symbols	Definition
	Indicates the danger of electric shock. If not avoided, it would cause casualties.
	Indicates a potentially dangerous condition which could result in injury or death.
	Indicates important information or warnings related to concepts talked about in the text.
	Indicates more information is available in other documents relating to the subject and reader.
	Indicates important steps or tips for optimal performance.



DANGER!
Fire & or Chemical Burn Hazard

- * Do not cover or obstruct any vent openings or install it in a zero-clearance compartment.



DANGER!
Failure to follow these instructions can result in death or serious injury.

- * When working with electrical equipment or lead-acid batteries, please arrange someone nearby in case of an emergency.
- * Study and follow all the battery manufacturer's specific precautions when installing, using and servicing the battery connected to the inverter.
- * Wear eye protection and gloves.
- * Avoid touching your eyes while using this unit.
- * Keep fresh water and soap on hand if battery acid comes in contact with eyes. If it occurs, clean right away with soap and water at least 15 minutes and then seek medical attention.
- * Batteries will produce explosive gases. DO NOT smoke or have an open spark or fire near the system.
- * Keep unit away from moist or damp areas.
- * Avoid dropping any metal tool or object on the battery. Doing so may create a spark or short circuit which goes through the battery or another electrical tool that may create an explosion.



WARNING!
Shock Hazard, Keep Away From Children !

- * Avoid moisture. Never expose unit to snow, water, etc.
- * The unit provides high voltage AC. Please treat the AC output socket the same as regular wall AC sockets at home.



WARNING!
Explosion Hazard !

- * DO NOT install the unit near flammable fumes or gases (such as propane tanks or large engines).
- * AVOID covering the vent openings. Always operate unit in an open area.
- * Prolonged exposure to high heat or freezing temperatures will decrease its lifespan.
- * DO NOT connect AC power sources like utility power or generator to the AC output of the unit. It will damage the unit and may cause fire. Feeding AC to the AC output of the unit is not covered by warranty.
- * The 12V DC unit is designed for 12V House Battery System only. Use on a higher house battery system will damage the unit and lead to explosion.
- * The 24V DC unit is designed for 24V House Battery System only. Use on a lower house battery system will damage the unit and lead to explosion.



LIMITATIONS ON USE

- * DO NOT use in connection with life support systems or other medical equipment or devices.

FCC and CE EMC INFORMATION

This equipment has been tested and found to comply with the limits for a Class B digital device, pursuant to part 15 of the FCC Rules (for 120V models) and comply with the CE EMC Standard on 230V models. These limits are designed to provide reasonable protection against harmful interference in the residential installation. This equipment generates, uses, and can radiate radio frequency energy. If it is not installed and used in accordance with the instructions, it may cause harmful interference to radio communications. However, there is no guarantee that interference will not occur in a particular installation. If this equipment does cause harmful interference to radio or television reception, it can be determined by turning the equipment off and on. The user is encouraged to correct the interference by one or more of the following measures:

- * Re-orient or relocate the receiving antenna.
- * Increase the separation between the equipment and the receiver.
- * Consult the dealer or an experienced radio/TV technician for help.

II. Introduction

Thank you for purchasing our Sine wave inverter-Charger. With our state of the art, easy to use design, this product will offer you reliable service by providing True Sine wave AC power for your home, cabin, boat, RV or trailer and recharge your battery automatically when utility AC is available. The Sine wave Inverter-Charger can run many AC-powered appliances when you need AC power anywhere. The multi-stage battery charger will charge different types of batteries. The built-in transfer switch will automatically switch the load to the battery power when the utility power is interrupted.

This manual will explain how to use this unit safely and effectively. Please read and following these instructions and precautions carefully.

III. Packing List

The Sine wave Inverter-Charger includes the items listed below.

- * Inverter-Charger base unit
- * Communication Input Cable: with American standard plug, 12AWG; 1m
- * Battery Connection Cable: 2/0 AWG; 1.5m
- * User Manual



120V Series

IV. Product Description



WARNING!

It is recommended that all wiring be done by a certified technician or electrician to ensure adherence to the applicable electrical safety wiring regulations and installation codes. Failure to follow these instructions can damage the unit and could also result in personal injury or loss of life.



CAUTION

Before beginning unit installation, please consider the following:

* The unit should be used or stored in an indoor area away from direct Sunlight heat, moisture or conductive contaminants.

* When placing the unit, allow a minimum of three inches of space around it for optimal ventilation.

Main Unit Front

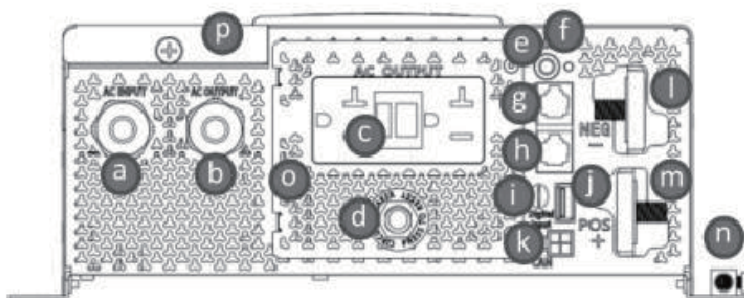

120V GFCI SERIES

Item	Description	Item	Description
a	AC input Hardwire Cable strain Relief	j	Program Port
b	AC Output Hardwire Cable strain Relief	k	CAN BUS Port
c	AC Output Socket	l	DC Negative Stud
d	AC Output socket Circuit Breaker	m	DC Positive Stud
e	Power button	n	Chassic Groud Connector
f	Power Indicator	o	AC Output Wiring Compartment
g	Remote Port	p	Ac Input & Output Wiring Compartment
h	Battery Temperature Sensor Port	q	Fans and fan guards
i	Ignition Start Port		

Main Unit Rear

UK

DE

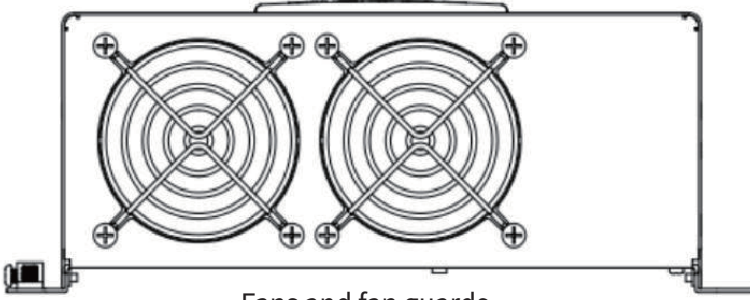

Fans and fan guards

Multi-Function Display

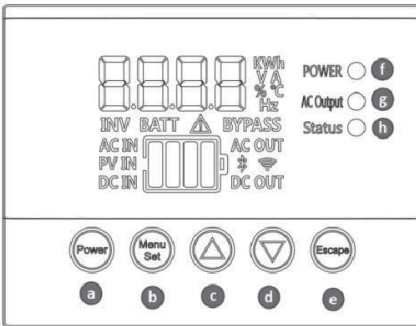

Item	Description
a	Power button
b	Menu button
c	Up button
d	Down button
e	Escape button
f	Power indicator
g	AC output indicator
h	Status indicator

Remote Control Display Panel(Optional)

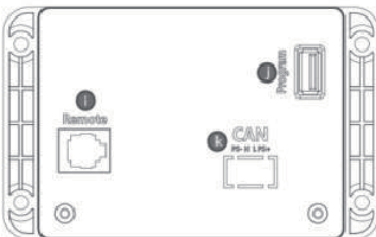
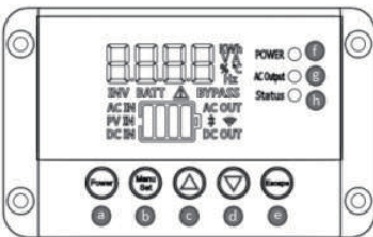

Item	Description
a	Power button
b	Menu button
c	Up button
d	Down button
e	Escape button
f	Power indicator
g	AC output indicator
h	Status indicator
l	Remote Panel Socket
j	Program Port
k	CAN-BUS port

Typical Wiring Block Diagram of Inverter-Charger

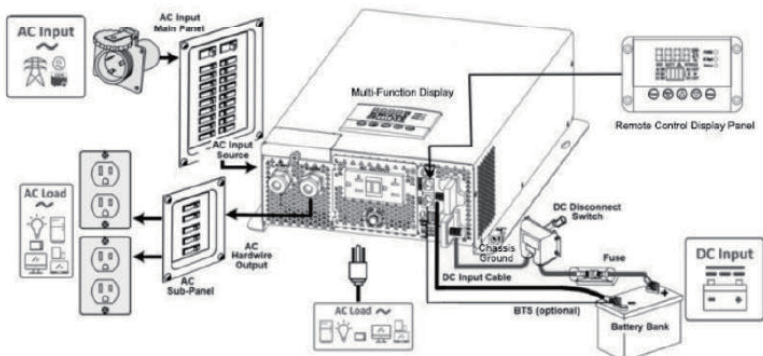

● Battery Bank

* The converter/inverter is intended to recharge batteries. The battery that is connected to this product is only suitable if it complies with the given battery standard for that battery type, and is provided with a battery management system that will monitor and control the electrical and thermal health of the battery during charging. When installing this converter/inverter, the battery is to be verified as in compliance with the applicable battery standard.

* The use of deep cycle or lithium ion battery is highly recommended for power inverter application.

* For battery size, you need to identify how much and for how long the inverter has to provide AC power to the loads (based on Amps x hour energy consumption). It is recommended to purchase as much battery capacity as possible.

AC Load	Estimated run time on 12V Battery bank on 12V Input Models	
	12V/120AH	12V/240AH
50W	22 hrs.	44 hrs.
100W	11.5 hrs.	23 hrs.
200W	5 hrs.	11 hrs.
500W	2 hrs.	4 hrs.
1000W	49 mins	2 hrs.
1500W	27 mins	1 hrs.
2000W	15 mins	49 mins
2500W	N.R.	37 mins
3000W	N.R.	27 mins

N.R.- Not Recommended. Based on more than 2C discharged on battery capacity.
Estimated run times are for reference use only. Actual run times may vary on battery type used.

● DC Fuse or Circuit Breaker

* DC-rated fuse or DC-rated circuit breaker connected along the DC positive line is required.

Fuse/Circuit Breaker Rating	12V 2000W System	12V 3000W System	12V 4000W System
	300 Adc	400 Adc	500 Adc

* Based on the size of the Battery Bank, determine the overall short circuit current rating of the battery bank from the battery manufacturer. The fuse or circuit breaker has to be able to withstand the short circuit current that can be supplied by the battery bank.

* For battery banks with total capacity under 500Ah, the most affordable ANL fuse type can be used. Otherwise please use Class-T type.

● DC Disconnect Switch

* A DC Disconnect Switch connected along the DC positive line is recommended. The rating of the switch is with the same or higher rating of the selected fuse or circuit breaker. Use ignition protected switches when required by local codes.

* This switch is used to disconnect the positive of the battery bank to the unit's positive terminal during maintenance/repair service, when not in use, or when troubleshooting. It could also be an A/B/A+B/OFF type switch to select either one of the two or both(paralleling) battery banks (if available).

● DC Input Cable

* All DC Input Wires should be insulated multi-strand low resistance wires.

* The DC wires must be copper and with minimum 105°C rating.

Model	Thinnest DC Input Wires Gauge Used		
	≤ 5 feet (Recommended)	≤ 7.5 feet	< 10 feet
12V 3000W series	120mm ² AWG #4/0	150mm ² 300 kcmil (MCM)	200mm ² 400 kcmil (MCM)
The typically recommended wire length is limited to 5 feet or less for each of the positive and the negative. For longer wires, a proportionally thicker gauge is required to compensate for additional voltage drop.			



CAUTION

These guidelines assume you are using the DC supplied cable and fuse sizes recommended in this manual. The use of a thinner gauge in the DC wires may cause the inverter to trigger the under-voltage shut down under heavy load conditions. It may also melt the wire insulation and catch fire, resulting in death or serious injury. The choice of the wire gauge should also match or exceed the ampacity rating of the DC fuse and holder being used.

● Chassis Ground



DANGER!

The unit chassis has to be grounded properly before use. Never operate the unit without proper grounding. Failure to do so will result in death or serious injury.

Model	Thinnest Wire Gauge Used	
	Recreation Vehicle	Marine
12V 3000W series	10mm ² /AWG # 8	AWG# 3/0
<p>- These guidelines assume you are using the DC supplied cable and fuse sizes recommended in this manual. If you are using different sizes, refer to the applicable installation code for the DC grounding detail.</p> <p>- In marine applications, the main AC-DC ground bonding may require galvanic isolators to manual avoid galvanic corrosion. Check your local electrical codes (i.e. NEC UL, ABYC...).</p>		

● AC Input Source

An AC source is usually grid power or an AC Generator. The acceptable AC Input voltage range and frequency are as shown:

Model	Acceptable Ac Input Voltage Range	Acceptable AC Input Frequency Range
120VAC series	90-140 VAC	30-100 Hz

An automatic or manual AC source selector switch can be used to switch between the multiple sources of shore power to the unit. Usually, the AC Main Panel includes a main circuit breaker that serves as over-current protection and as a disconnect for the AC shore power supply line. Additional AC circuit breakers serve individual circuits and one of the AC circuit breakers will serve the unit. During By-Pass mode, the AC Input source will serve the AC Output Load and also the AC Input current for the charger when it is used to charge the battery.

Model	AC Input Circuit Breaker to serve the unit	AC Input Wire
120VAC series	30A(maximum)	6mm2/#10 AWG(minimum)
230VAC series	20A(maximum)	4mm2/#12 AWG(minimum)
- Follow the electrical and/or building code when you choose AC Branch Breaker and AC Input wire Size. Connect the unit to any AC Input Source. - Smaller size AC input wire can be used when a lower amperage rated AC input Circuit Breaker is used from upstream to feed the unit.		

The unit is designed to accept non-Sine wave AC Input Source supplied by a generator.

● **AC Hardwire Output**

An AC Sub-Panel is recommended to incorporate an AC output circuit breaker and breakers for individual load circuits. Use the same wire size as the one used for the AC input wire.

● **AC Output Socket and**

● **AC Output Thermal Breaker**

A single AC Output socket is provided for direct AC output from the unit. An over-current protective device (thermal breaker) is connected in series with the AC Output Socket to avoid excessive current being drawn from it.

Model	AC Output Socket Type	AC Output Thermal Breaker
120VAC series	NEMA 5-20 GFCI	20A

● **Multi-Function Display**

The display is used to provide unit information and for unit setting.

● **Remote Control Port**

The port is used to connect to the Remote Control Display. And it is used to provide unit information and for unit setting.



● BTS Port

The port is used for connecting to the optional Battery Temperature Sensor. The thermistor installed inside the ring terminal is used to measure the battery terminal temperature and the unit will make compensation on battery charging voltage for battery charging.

● Ignition Start Port, Program Port, CAN-BUS Port

The Ignition Start Port is used for connecting to the ignition start signal from vehicles to control the operation of the inverter.

Program Port

This USB port is for system firmware upgrade use only. This CANNOT be used for charging Smart phones or USB powered devices. Misuse of this port can potentially damage the unit and is not covered by the warranty. The USB port is located on the Inverter-Charger and an extra port that shares the same function is also located on the back of Remote Control Display.

CAN-BUS Port

This is for unit communication through the CAN interface. Misuse on this port can potentially damage the unit and is not covered by the warranty. This port is located on the Inverter-Charger and an extra port that shares the same function is also located on the back of Remote Control Display.

Information on the CAN-BUS plug/connector:

* Input voltage: 8 VDC - 17 VDC

* Input amperage: 5mA typical, 60mA Max @12V

CAN-BUS
Connector(on inverter)

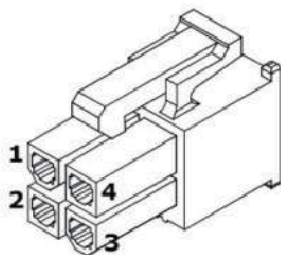
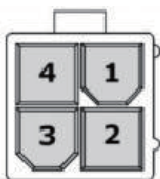

CAN-BUS Plug
(cable end)

Pin	Designation
1	PS-
2	CANH-H
3	CAN-L
4	PS+

V. Installing The Unit



WARNING:
Explosion hazard!

- * DO NOT install the unit near flammable fumes or gases (such as propane tanks or large engines).
- * AVOID covering the ventilation openings. Always operate unit in an open area.

Choosing the location:

- * The unit should only be installed in locations that meet the following requirements. Do not allow water or other fluids to drip or splash on the unit.
- * Environment temperature should be between -4°F and 104°F (-20°C and 40°C).
- * Allow at least three inches of clearance around the unit. The more clearance for ventilation around the unit, the better the performance is.

Mounting the Unit:

- * Choose an appropriate mounting location.
- * The unit can be mounted in any direction.
- * Use the mounting template below to mark the positions of the mounting screws.
- * Drill the 4 mounting holes, place the unit in position and fasten the unit to the mounting surface.

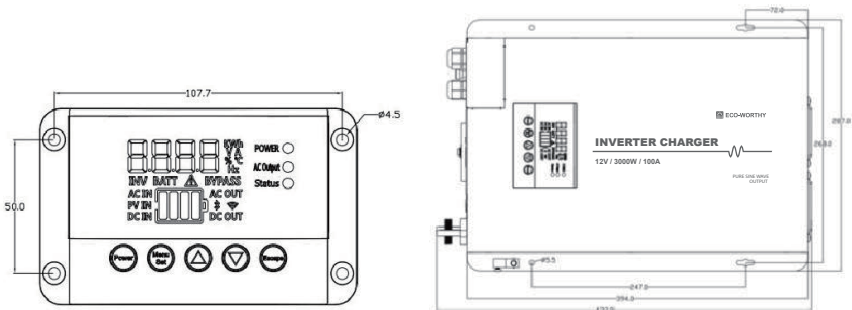



Remote control display panel
(All dimensions in mm)

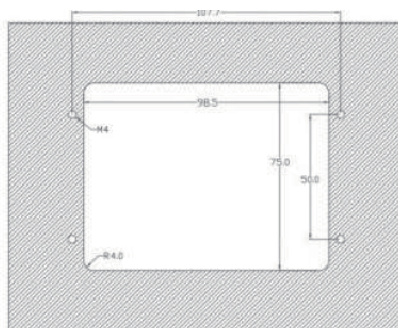

DC Input Connection:



WARNING!
Electrical Shock Hazard!

The unit “On/Off” switch does not disconnect the DC power from the battery. Use the DC Disconnect Switch or disconnect the DC input cables to disconnect the DC power from the battery before working on any circuits connected to the unit. Failure to follow these instructions can result in death or serious injury.



CAUTION

Reversing the DC Input terminals will damage the unit and it cannot be repaired. Damage caused by reverse polarity connection is not covered by the warranty.



IMPORTANT

Field wiring Dc terminals tightening torque 12 - 13 Nm

- * Connect a negative DC Input cable between the unit DC negative terminal and battery negative terminal.
- * Make sure the Disconnect Switch is in the OFF position. Connect a positive DC Input cable between the unit DC positive terminal and one terminal of the Disconnect Switch.
- * Connect another DC Input cable between the other terminals of the Disconnect Switch to one side of the terminal of the fuse holder or DC rated circuit breaker(OFF position).

* Connect another Dc input cable between the other terminal of the fuse holder or DC rated circuit breaker to the battery positive terminal.

Note: For Marine application, either the DC fuse or DC rated circuit breaker needs to be installed within 7 inches (18 cm) from the battery positive terminals.

* Install the selected fuse to the fuse holder.

Chassis DC Ground connection:

* Connect the grounding wire to the unit's Chassis DC Ground Lug located near the DC Input terminal and the other side of the cable to the common grounding point.

* For a Recreation Vehicle, the common ground point is usually the vehicle chassis or a dedicated DC ground bus.

* For Marine, the common ground point is usually the DC ground bus or engine negative bus.

Note: Do not use the Chassis DC Ground Lug for your AC Grounding. For AC Grounding, see AC Wiring instructions for more details.

AC Input and AC Output Hardwire Connections:



WARNING!

Before making any AC Input and AC Output Hardwire connection, please be sure the AC Input Source is not energized and the DC disconnect switch is switched OFF. Please double check the location of the AC input connector located inside the wiring compartment. Misconnecting to the AC output connector inside the same compartment will damage the unit and may cause fire.

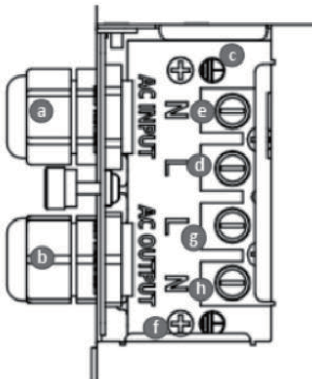

Item	Description
a	AC INPUT STRAIN RELIEF
b	AC OUTPUT STRAIN RELIEF
c	AC INPUT GROUND
d	AC INPUT LIVE
e	AC INPUT NEUTRAL
f	AC OUTPUT GROUND
g	AC OUTPUT LIVE
h	AC OUTPUT NEUTRAL

Remove the AC wiring compartment cover by unscrewing the one screw located at the front of the AC wiring compartment cover.

For AC Input connections:

* Insert the AC Input cable through the AC input Strain relief on the unit.

* Connect the AC Main Panel AC Ground wire to the AC Input Ground terminal on the unit.

If a solid ground wire is used, the wire can be connected directly under the screw head. If a stranded ground wire is used, ring terminals must be used.

* Connect the AC Main Panel AC Live to unit's AC Input 'L' Live terminal.

* Connect the AC Main Panel AC Neutral wire to unit's AC Input Neutral 'N' terminal.

* Tighten the strain relief to secure the AC Input wire.

For AC Output Hardwire connections:

* Insert the AC Output cable through the AC Output Strain relief on the unit.

* Connect the AC Sub-Panel AC Ground wire to the AC Output Ground terminal on the unit. If a solid ground wire is used, the wire can be connected directly under the screw head. If a stranded ground wire is used, ring terminals must be used.

* Connect the AC Sub-Panel AC Live to unit's AC Output 'L' Live terminal.

* Connect the AC Sub-Panel AC Neutral wire to unit's AC Output Neutral 'N' terminal.

* Tighten the strain relief to secure the AC output wire.

Remote Display Connection:

Route the Rj12 cable from the unit to your desired location for the Remote Control Display and connect one end of the cable to the main unit Remote Port and the other end of the cable to the Display Panel socket located at the rear panel of the Remote Control Display.

BTS(Battery Temperature Sensor) Connection (optional):

To provide more accuracy and precision on battery voltage charging against battery temperature, a BTS (sold separately) can be used. The BTS can also be used to terminate the charging cycle when it senses the temperature of the battery rise to above 60 °C or fall below 0 °C. See "Understanding the Error Code " E19 -E21 for more details. Use the following procedures to install the BTS.

* Connect the Rj12 end of the BTS cable to the BTS Port on the main unit.

* Install the ring terminal end of the BTS cable to the negative terminal of the battery bank.

Ignition Start Port Connection (optional):

The ignition start connection provides an inverter ON/OFF function through the Ignition Start Port. See more details on Understanding of Ignition Start On/Off function.

Quick Test on Unit after Installation:

* Connect a small Ac load like a 60W light bulb to the AC Output of the unit.

* Switch DC disconnect switch to ON to provide battery power to the unit, then press and hold On/Off button on Main unit or 'Power' button on Display panel for 1 second to turn unit or inverter ON.

* The 'Status' LED on display will turn Amber indicating inverter is ON. AC Output LED turns green indicating the AC is available.

* Verify the 60W light bulb is ON.

* Switch ON the Main Circuit Breaker on the AC Input Panel.

* Switch ON the Ac Input Circuit Breaker that provides AC input power to the unit.

* If AC input source is available, the 'Status' LED amber will flash for about 10 seconds indicating the AC input source is available. It will then turn to solid green or flashing green indicating the unit is running from the Ac input source.

* Verify the 60W light bulb remains ON.

* The unit is successfully installed and functioning properly.

Ground Fault Circuit Interrupters (GFCIs) and Monthly Testing (120VAC 2000W/ 3000W/4000W model)

A GFCI is a device that de-energizes a circuit when a current to ground exceeds a specified value that is less than that required to blow the circuit breaker. GFCIs are intended to protect people from electric shocks and are usually required in wet or damp locations.

Installations in marine and recreation vehicles require GFCI protection of branch circuits connected to the AC output of the unit.

For units equipped with GFCI, the GFCI function is required to be tested monthly

* To test the GFCI, turn unit ON either in By-Pass mode or battery power mode. Plug a small AC load (e.g. 40W light bulb) to the AC Output GFCI Socket.

* Check that the AC load is ON.

* Press the 'TEST' button to trip the GFCI protection. A clicking sound should be observed. Check that the AC load is turned off.

* Press the 'RESET' button until hearing a click to reset the GFCI outlet.

* Check that the AC load is back ON again.

Note: Be aware that a tripped GFCI outlet cannot be reset with the unit operating in Battery Power Mode and with the Load Sense setting activated. Turn load Sense feature Off before resetting the tripped GFCI.

How to Reset the GFCI outlet when tripped (120V AC 2000W/3000W /4000W model if available):

When Utility AC input Source is available:

* Unplug all the AC loads from the unit's GFCI outlet.

* Press the 'RESET' button until hearing a click to reset the GFCI socket.

* Plug in the AC Loads and verify the AC Load is ON.

When Utility AC Input Source is not available:

* Unplug all the AC loads from the unit's GFCI outlet.

* Turn unit On and be sure the unit is running in Battery Power Mode.

* Check/Set the Load Sense 'F50' setting to off.

* Press the 'RESET' button until hearing a click to reset the GFCI socket

* Press the 'RESET' button until hearing a click to reset the GFCI socket

* Plug in the AC Loads and verify the Ac Load is ON.

Note: Be aware that a tripped GFCL outlet can only be Reset when there is a continuous AC input supplying to the GFCL Socket.

V. UNIT OPERATION

The unit is preset with factory default settings and will fulfill the basic needs for inverter-charger operation. The display is used to provide information about the unit status and the unit function can be customized through the Display.

Understanding the Indicator/Push Button/Unit Functions

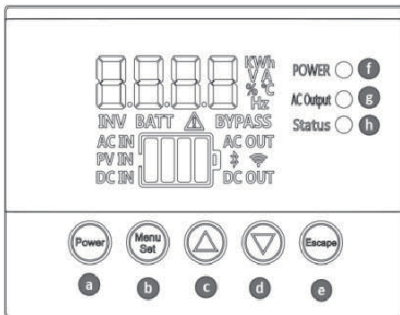

Item	Description
a	Power button
b	Menu button
c	Up button
d	Down button
e	Escape button
f	Power indicator
g	AC output indicator
h	Status indicator

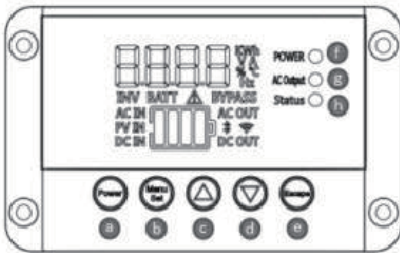

Item	Description
a	Power button
b	Menu button
c	Up button
d	Down button
e	Escape button
f	Power indicator
g	AC output indicator
h	Status indicator
i	Remote Panel Socket
J	Program Port
K	CAN-BUS port

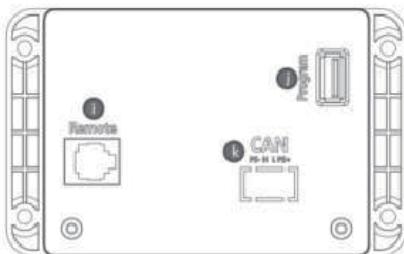

Indicator	Status	Function
Power	ON	Unit is power ON.
AC Output	ON	AC output is available.
	OFF	AC output is not available.
Status	Green	AC Output is running from Utility.
	Green (Flash)	AC Output is running from utility and battery charger is charging the battery.
	Amber	AC Output is running from Inverter.
	Amber (Flash)	Utility is detected and is under verification. AC Output is still running from inverter and will switch to Utility in about 10 seconds.
	Red	Error/Warning occurs. Display will show Error or Warning code.

Normal Operation

When unit is On, the Multi-Function display shows Battery Voltage 'V'. Pressing any button will illuminate the backlighting of the display for about 10 seconds.

'Power' button (Same function as the green 'On/Off' push button on the main unit):

- To turn the inverter ON: press and hold until hearing the beep (in about 1 sec.). All icons in the display turn ON, followed by the Display revision levels 'Dx.x' and then the Display revision levels 'rx.x' (where x= any number).

- To turn the inverter OFF: press and hold until hearing the beep (in about 1 sec.). Display turns off and the unit cannot be turned on again but after about 3 sec (when hearing the deactivation of the internal relays).

Note: When AC input is available, this 'Power' button cannot be used to turn OFF the unit.

Menu/Set button:

- Press once to view unit setting on display. See more details on Viewing and Change Unit Setting section.

▼ and ▲ button:

- The ▲ or ▼ V can be used to scroll through DC Current 'A' , AC Output Power 'KW' and Battery Voltage 'V'.

- Press and hold ▲ and ▼ buttons together for 2 seconds to show firmware revision numbers.

- 'Escape' button: Press once to return back to Normal Operation.
- Press and hold for 5 seconds to turn OFF or ON the AC Output Switch (Optional)
(Use this button as an AC Output ON/OFF function for the Output)

Viewing and Change Unit Setting

- When unit is in normal operation mode, Press "Menu/Set" button once to view unit setting as listed on the Unit Setting Function Chart.
- The ▲ or ▼ button can be used to scroll through each unit setting. If a particular setting needs to be modified, press and hold the 'Menu/Set' button for 5 seconds and the set parameter will flash on the display. Use the ▲ or ▼ button to scroll through the available settings. Once the desired setting is chosen, press and hold the 'Menu/Set' button until a beeping sound occur and the new setting is saved.
- Press 'Escape' button once to return back to Normal Operation. (If none of the button is triggered for about 5 seconds, display will also return back to Normal Operation.)

Unit Setting Function Chart

Unit Setting	Display	Description and Available Setting
Battery Low Disconnect	F01 10.5*	Battery Low Disconnect Voltage selectable ranges is 10.5 -12.0V (0.1Vsteps)* (Default voltage is set to 10.5V*)
Battery Low Warning	F02 11.0*	Battery Low Warning Voltage selectable ranges is 11.0 - 12.5V (0.1V step)*(Default voltage is set to 11.0V*)
Battery Low Recovery	F03 12.0*	Battery Low Recovery Voltage selectable ranges is 11.5 - 13.0V (0.1V step)(Default voltage is set to 12.0V*)
Power Save Time	F04 OFF	The range is from 1 to 25, adjusted by 1-h increments. The next Setting after 25 is OFF. When total load is less than 25W.
Load Sense	F05 OFF	OFF (Default): Continuous AC Output when inverter is ON 15 : Continuous AC Output when inverter is ON and Ac load is > 15W 25 : Continuous AC Output when inverter is ON and Ac load is > 25W
Audible Buzzer	F02 11.0*	Battery Low Warning Voltage selectable ranges is 11.0 - 12.5V (0.1V step)*(Default voltage is set to 11.0V*)
Battery Low Warning	F06 ON	ON (Default): Buzzer is enabled. Unit buzzes when Warning or Error occurs OFF: Buzzer is disabled. Unit does not buzz when Warning and Error occur.
Inverter	F07 ATO	INV :Use as Inverter only. No By-Pass functions
		ATO(Default): Auto Backup. Inverter automatically turns ON when ACBlackout.
		OFF: Inverter function is disabled. No AC backup when AC Blackout.









AC Charger	F08 ON	ON (Default): AC Charger is enabled. Charge battery when AC input is available. OFF:AC Charger is disabled. No battery charging when Ac Input is available.
Battery Type	F09 GEL	6EL (Default): GEL Battery, default Bulk Charge/Float Voltage is 14.2V/13.8V*
		A6M : AGM Battery, default Bulk Charge/Float Voltage is 14.3V/13.4V*
		fld : Flooded Battery, default Bulk Charge/Float Voltage is 14.4V/13.5V*
		li : Lithium Battery, default Bulk Charge/Float Voltage is 13.9V/13.5V*
		p6M : Program, default Bulk Charge/Float Voltage is 13.8V/13.2V*
	p5y : Power Supply Mode, Default Power Supply Voltage is 13.8V	
Bulk Current	F010 120*	12V/4000W Models: Selectable Ranges 120A,80A,60A,40A,25A(Default 120A).
		12V/3000W Models: Selectable Ranges 100A,80A,60A,40A,25A(Default 100A).
		12V/2000W Models: Selectable Ranges 80A,60A,40A,20A,10A(Default 80A).
		24V/4000W Models: Selectable Ranges 60A,40A,30A,20A,10A(Default 60A).
		24V/3000W Models: Selectable Ranges 50A,40A,30A,20A,10A(Default 50A)
	24V/2000W Models: Selectable Ranges 40A,30A,20A,10A,5A(Default 40A).	
Bulk/Absorption Voltage	F11 14.2*	Bulk/Absorption voltage is based on the battery type chosen. All battery types have selectable ranges of 13.8-14.8V*.(Default on GEL Battery is 14.2V*)
Absorption to Float Current	F12 12A	12V/4000W Models: Selectable Range: 20A,15A, 12A, 5A,2A (Default 12A)
		12V/3000W Models: Selectable Range: 20A,15A, 10A, 5A, 2A (Default 10A)
		12V/2000W Models: Selectable Range: 15A, 10A, 8A, 4A, 2A (Default 8A)
		24V/4000W Models: Selectable Range: 8A, 6A, 5A, 3A, 2A (Default 6A)
		24V/3000W Models: Selectable Range: 8A, 6A, 5A, 3A, 2A (Default 5A)
	24V/2000W Models: Selectable Range: 6A, 5A, 4A, 3A, 2A (Default 4A)	
Float Voltage	F13 13.8*	Float voltage is based on the battery type chosen. All battery types have selectable ranges of 13.0-14.0V. (Default on GEL Battery is 13.8V*)
Recharge Voltage	F14 12.8*	Battery Recharge Voltage Selectable Range: 12.8 to 14.0V (0.1V step)*(Default on GEL, AGM, Flooded, PGM battery setting is 12.8V* and Libattery setting is 13.2V)
Battery Temperature	F15 Nor	Hi: High > 35 °C Nor (Default): Normal 15 -35°C Low : Low < 15°C
AC Input Source Circuit Breaker	F16 30A	120 Vac Models: Range: 30A,20A,15A (Default 30A).230 Vac Models: Range:16A,13A,10A(Default 16A on EU, 13A on UK and AU).
Equalize Charging for Flooded Battery	F17 OFF	OFF(Default):CHG EQU is disabled. 1H : only one hour of equalize charging once. This setting is only available when Flooded battery type is selected. It allows only one hour to equalize charging once.

Output Frequency	F18 50HZ	50HZ or 60HZ After changing the output frequency setting, turn the unit off and then on again, in order for the change to take effect.
Output Voltage	F19 120V	120V Series Output Voltage Range: 120V, 110V, 100V; (Default 120V) 230V Series Output Voltage Range: 240V, 230V, 220V; (Default 230V) After changing the output Voltage setting, turn the unit off and then on again, in order for the change to take effect.
Factory Default	F20 no	Select YES to reset all settings to default.

*For 24V Models (LF-BIC02400601, LF-BIC02300501, LF-BIC02200401, LF-BIC02400602, LFB1C02300502, LF-BIC02200402), all voltage values are doubled.

Understanding the Display Icons during Unit Operation

Icons	Meaning
BYPASS	<p>Solid: Unit is running in ByPass mode. (The transfer switch is switched to AC Input Source).</p> <ul style="list-style-type: none"> - AC Output power is running from AC Input Source. - AC Output is available at both the AC Output socket and the AC Output Hardwire terminal (indicated by AC Output indicator located on the right side of the Display)
AC IN	<p>Solid: AC Input is available and is in the operating range</p> <p>Flashing: AC Input is detected and is under verification before switching to Bypass mode. This normally takes about 10 seconds.</p>
AC OUT	<p>Solid: Unit is running in Battery Mode (The transfer switch is switched to inverter)</p> <ul style="list-style-type: none"> - AC Output power is running from the inverter - AC Output is available to both the AC Output socket and the AC Output Hardwire terminal (indicated by AC Output indicator located on the right side of the Display)
 Battery Inverter Mode	<p>Battery bar(s) in solid indicates the unit is in Battery Mode. The bars show estimated remaining battery power.</p> <ul style="list-style-type: none"> 4 solid bars: Battery is Full 3 solid bars: Battery capacity with 75% remaining 2 solid bars: Battery capacity with 50% remaining 1 solid bar: Battery capacity with 25% remaining No bar: Battery is empty. Inverter will shut down when it reaches under-voltage shutdown point. <p>Note: This indicator is for reference use only. It varies depending on battery health or type used.</p>
	<p>Battery bar(s) with the last bar flashing indicates the unit is running in Bypass mode and the battery charging process is in progress. The charging stages are indicated by and the number of bars.</p>

 Charger Mode		4 bars in solid: indicates the battery is fully charged and it is in Float stage.
		The last bar flashing: indicates the battery is in Absorption charging stage.
		The third bar flashing: indicates the battery is in Bulk charging stage and the battery is >13.5V.
		The second bar flashing: indicates the battery is in Bulk charging stage and the battery is >12.5V.
		The first bar flashing: indicates the battery is in Bulk charging stage and the battery is > 11.5V.
		No bar: indicates the battery is in Bulk charging stage and the battery is >10.5V.
		Battery icon flashing: indicates the battery is in Bulk charging stage and the battery is below 10.5V.

Display Character	Meaning
28 ^A	'A' icon on indicates the display shows battery discharge current (28A as shown)
0.80 ^{KW}	"KW" icon on, it indicates the display shows AC Output power in KW(0.80 KW = 800W as shown)
12.8 ^V	'V' icon on, it indicates the display shows battery voltage in V (12.8V as shown)
E01 [△]	Warning icon on, it indicates the display shows Error/Warning Code (E01 as shown Battery Low Disconnected error)
E9.0 [△]	Equalization on Flooded battery is in process. This function is available for use with Flooded battery type only. The display will also show the equalization voltage during the process. Follow the instruction provided by the battery manufacturer when performing the equalization process.
d0.5	Indicating the Display Panel firmware revision
r0.2	Indicating the Main Unit firmware revision

Exploring the Unit Settings

a) Inverter and Charger Functions

F07(Inverter)	F08(CHG)	AC INPUT	AC OUT	CHARGE	FUNCTIONING	COMMENT
ATO	ON	ON	Bypass	Y	Auto Backup	Commonly used default setting
ATO	ON	OFF	Backup	-		For external charger
ATO	OFF	ON	Bypass	N		
ATO	OFF	OFF	Backup	-		
OFF	ON	ON	Bypass	Y	Transfer Switch	
OFF	ON	OFF	-	-		Bypass only
OFF	OFF	ON	Bypass	N		
OFF	OFF	OFF	-	-		
INV	ON	ON	Backup	N	On-Line UPS	
INV	ON	OFF	Backup	N		Inverter only
INV	OFF	ON	Backup	N		
INV	OFF	OFF	Backup	N		

b) Load Sense Function

Load Sense Mode	
F05	This Load Sense function is only effective when the unit is running as inverter(Battery power) mode.
	'Off' : Unit provides continuous AC Output power all the time.
	15: Load Sense power setting is set to 15W. Unit will provide continuous AC Output only when the AC load connected to the AC Output is >15W. AC Output will switch back to pulsing AC Output every few seconds when the AC Load connected is approximately 12W or less. 25: Load Sense power setting is set to 25W. Unit will provide continuous AC Output only when the AC load connected to the AC Output is >25W. AC Output will switch back to pulsing AC Output every few seconds when the AC Load connected is approximately 20W or less.
<p>* The Load Sense Power rating is available at power levels of 15W and 25W.</p> <p>* This setting is designed to reduce battery power when the unit is running as invertei and the AC Load demand is small.</p>	

c) Battery Disconnect Function

Battery Under and Over Voltage Setting	
F01 10.5	Battery Low Disconnect Voltage selectable range: 10.5 - 12.0V (0.1V step)(Default 10.5V)
	The Battery Low Disconnect Voltage has to be with a minimum of 0.5V below the Battery Low Alarm (F02) Voltage.
F02 11.0	Battery Low Alarm Selectable range: 11.0 -12.5V (0.1V step) (Default 11.0V)
	The Battery Low Alarm Voltage has to be with a minimum of 0.5V above the Battery Low Disconnect (F01) Voltage and has to be with a minimum of 0.5V below the Battery Low Recovery (F03) Voltage.

F03 12.0	Battery Under Voltage Recovery selectable range: 11.5 - 13.0V (0.1V step)(Default 12.0V)
	The Battery Low Recovery Voltage has to be with a minimum of 0.5V above the Battery Low Alarm(F02) Voltage.
Battery Over Voltage Disconnect	16.5V (Not User selectable)
Battery Over Voltage Recovery	16.0V(Not User selectable)
Note: For 24Vsystem, all voltages are doubled.	

d) Alarm Function

Alarm Setting	
F06	Fault and warning audible alarm can be enabled (On-Default) or disabled(Off).

e) Power Saving Shutdown Time Setting Function

Power Saving Shutdown Time setting	
F04	Power Saving Shutdown Time function can be enabled (ON) or disabled (OFFDefault).The range is from 1 to 25, adjusted by 1-h increments. The next setting after 25 is OFF. The shutdown time will be calculated when the total load is less than 25W

f) AC Output Frequency 50HZ or 60HZ Function

Output Frequency 50HZ or 60HZ Function Setting	
F18	Output Frequency 50HZ or 60HZ Function SettingNote: After changing the output frequency setting, turn the unit off and then on again, in order for the change to take effect.

g) AC Output Voltage Function

AC Output Voltage Function Setting	
F19	120V Series Output Voltage Range: 120v,110V,100V; (Default 120V) 230V Series Output Voltage Range: 240V,230V,220V; (Default 230V) Note: After changing the output voltage setting, turn the unit off and then on again, in order for the change to take effect.

h) Charger Functions

GEL, AGM, Flooded and Program Battery Charging Profile

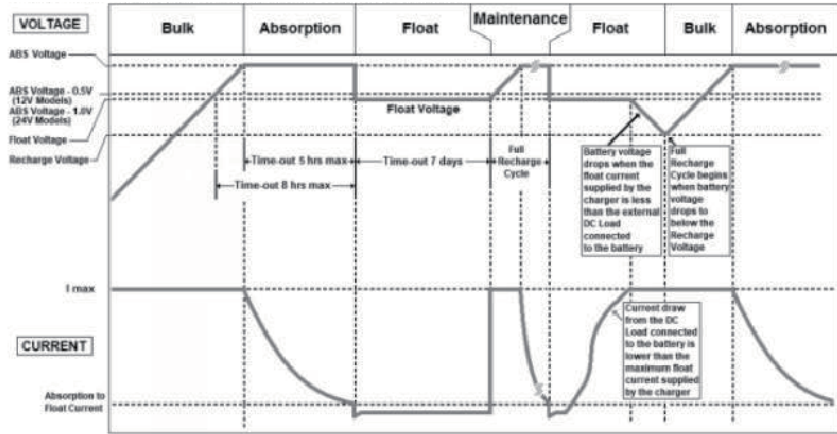

Lithium Battery Charging Profile

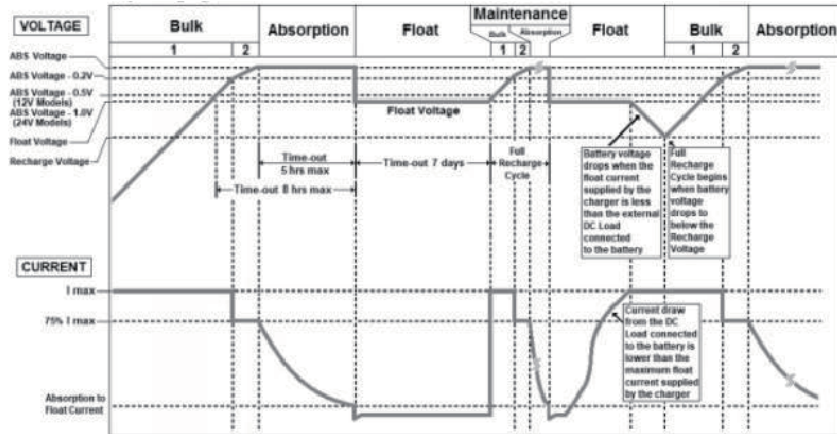

Battery Charging Cycle

Charging Voltage Setting: Bulk/Absorption (ABS), Float (FLO) and Recharge (REC)			
Battery Type	Bulk Voltage (Default)	Float Voltage (Default)	Recharge Voltage (Default)
GEL	13.8-14.8V (14.2V)	13.0-14.0V (13.8V)	12.8-14.0 V(12.8V)
Flooded	13.8-14.8 & 15.8V(14.4V)	13.0-14.0V (13.5V)	12.8-14.0 V (12.8V)
AGM	13.8-14.8V (14.3V)	13.0-14.0V (13.4V)	12.8-14.0 V (12.8V)
Lithium	13.8-14.8V(13.9V)	13.0-14.0V (13.5V)	12.8-14.0V(13.2V)
Program	13.8-14.8V(13.8V)	13.0-14.0V (13.2V)	12.8-14.0 V(12.8V)
Power Supply	13.0-14.0V (13.8V)		

* Consult the battery manufacturer when choosing the Bulk and Float Voltage for the battery bank.

* When selecting the Float Voltage, it has to be with a minimum of 0.4V below Bulk Voltage setting.

* The Recharged Voltage determines the restart cycle of the battery bank. The charger will go through a full recharge cycle when the battery voltage drops to the Recharge Voltage set value.

When selecting the Recharge Voltage, it has to be with a minimum of 0.4V below the Float Voltage setting.

* If Power Supply is chosen, the charger will provide a constant voltage to charge the battery bank.

Note: For 24V system, all voltages are doubled.

Charging Current Setting: Bulk Stage (F10), Absorption to Float Stage (F12)		
Model	Bulk Stage	Absorption to Float Stage
12V 3000W	100A,80A,60A,40A,25A (Default: 100A)	20A,15A,10A,5A,2A (Default: 10A)

* Consult the battery manufacturer when choosing the Bulk Stage charging current of the battery bank. For a sealed lead acid battery, the rule of thumb for the maximum charging current is 1/5 of battery capacity.

* The Absorption to Float Stage current determines the transition from Absorption Stage to Float Stage. If an external DC load is connected to the battery bank, a higher current setting is recommended to compensate for the extra current drawn from the external DC load.

* In order to avoid the tripping of the external AC Source Branch Breaker, when high powered AC loads are connected to the AC Output, the charging current will automatically be reduced so that the total AC Input current (AC Output Current + AC Charger Current) is maintained below the set values of the AC Input Circuit Breaker (F16). See more details on **AC Source Circuit Breaker Function**.

Note: When the battery charging process starts, the unit will first measure the battery voltage. If it senses the battery voltage is below 9.5V, the charger current will automatically reduce to < 25A. It will resume back to the set charger current when the battery is charged to above 9.5V in 15 minutes. See more details on section Understanding the Error Codes(E01 and E11)

Battery Temperature Setting 'F15' (voltage adjustment from 25°C setting)

No Battery Temperature Sensor(BTS) installed

There are three settings (Low, Normal, High) available for battery temperature setting.

* Setting to 'Low' temperature will compensate the charging voltage by +0.675V on GEL and Flooded battery type and +0.525V on AGM battery type.
Setting to 'Nor' will have no change to the selected charging voltage.

* Setting to 'Hi' temperature will compensate the charging voltage by -0.27V on GEL and Flooded battery type and -0.21V on AGM battery type.

Optional Battery Temperature Sensor (BTS) installed (Part Number: BTS10K).

* If the temperature measured by the BTS is below 25°C, the charging voltage will be compensated with +0.027V per °C on GEL and Flooded battery or +0.021V per °C on AGM battery.

* If the temperature measured by the BTS is above 25c, the charging voltage will be compensated with -0.027V per °C on GEL and Flooded battery or -0.021V per °C on AGM battery.

There is no voltage adjustment compensation when battery type of Lithium, Program or Power Supply is selected.

Note: For 24V system, all voltage values are doubled.

Flooded Battery Equalization(F17)Setting:

Equalization setting can only be set on Flooded batteries. Before the equalization begins, the unit will automatically fully charge the battery first, followed by one hour of equalization. Consult and follow the instruction provided by the battery manufacturer when performing the equalization process.

* Select 'F17' under setting 1H.

* The unit will start a full flooded battery charging cycle first before the Equalization begins. The Equalization Voltage is set to 15.8V and current is limited to 1/10 of the set Bulk Stage Charging Current.

* Display will show 'F17' and the battery voltage during the Equalization period.

* The unit cannot determine when to terminate the equalization of the battery. A one-hour timeout is set as a safety feature and requires the user to continually re-activate it as necessary after checking the batteries manually.

* To terminate the Equalization process, change and save the battery type to other types like AGM, GEL etc. and then change and save it back to the Flooded type battery.

Note:For 24V system,all voltage values are doubled.

Flooded Battery Equalization(F17)Setting:

Equalization setting can only be set on Flooded batteries. Before the equalization begins, the unit will automatically fully charge the battery first, followed by one hour of equalization. Consult and follow the instruction provided by the battery manufacturer when performing the equalization process.

* Select 'F17' under setting 1H.

* The unit will start a full flooded battery charging cycle first before the Equalization begins. The Equalization Voltage is set to 15.8V and current is limited to 1/10 of the set Bulk Stage Charging Current.

* Display will show 'F17' and the battery voltage during the Equalization period. The unit cannot determine when to terminate the equalization of the battery. A one-hour timeout is set as a safety feature and requires the user to continually re-activate it as necessary after checking the batteries manually.

* To terminate the Equalization process, change and save the battery type to other types like AGM, GEL etc. and then change and save it back to the Flooded type battery.

Note:For 24V system,all voltage values are doubled.

Battery Recharge Timer:

The charger will restart a full charging cycle automatically if the float stage is maintained for 7 days.

i) AC Source Circuit Breaker Function

AC Source Circuit Breaker Setting

F16	120VAC Models: Selectable Values: 30A, 20A, 15A (Default: 30A)
------------	---

This setting limits the total AC current draw from the AC Source during the ByPass Mode to avoid tripping the AC Source Circuit Breaker. The selected value has to be the same or smaller than the rating of the AC Source Circuit Breaker.

j) Manufacturing Factory Default Function

Factory Default Setting	
F20 NO	Select 'Yes' to reset all the settings to the preset Factory Default settings.
Note: The setting for battery type is GEL. If another battery type is used, select 'Yes' to set all the parameter to factory default, then proceed to the battery type and make change to the new battery type.	

k) Understanding of Ignition Start ON/OFF Function

Providing +12V to the Ignition Start port will turn ON the inverter and removing the +12V will turn OFF the inverter.

Use of the 'Ignition Start' port located on the main unit will override the 'Power' On/Off function of both the Multi-Function Display and the main unit.

AC Load on Inverter

Although the Inverter-Charger can provide high surge power up to two times the rated output power, some high surge loads like air conditioners, sump-pumps, heavy-duty motors, etc. may still trigger the inverter protection system even though the load falls within the power rating of the inverter. A higher power Inverter-Charger is required for these appliances.

Understanding the Error Codes

Code	Condition	Corrective Action
E01 (Battery Mode)	No AC Output. Inverter shutdown due to low battery voltage.	Recharge the battery immediately and restart unit.
	Note: E01 will show for about 30 sec. After 30 sec, display will turn Off and unit will shutdown completely.	
E01 (Bypass Mode)	No battery is connected to the unit.	Check the battery connection.
	Battery voltage remains < 9.5V. A large portion of the charger current provided is used to maintain the DC load connected to the battery. E01 will turn OFF when the battery voltage is charged to > 9.5V	Remove or turn off Dc load connected to the battery to minimize the charging time to charge the battery to >9.5V, If this condition is ignored the charger will terminate the charging process(See note below).
	Note: The charger current with battery voltage < 9.5V is limited to ~ 10A and there is a 15 minutes timer to allow the charger to charge the battery to > 9.5V, If battery voltage remains < 9.5V afel 15 minutes ofcharging, the charger will shutdown and show E11 (Bad battery).	

Code	Condition	Corrective Action
E02	When unit is in Battery/Inverter mode, unit senses the battery voltage is too high and inverter has shutdown.	Check battery voltage or determine if any external charger is connected to the battery bank that leads to high battery voltage.
E03	When unit is in Battery/Inverter mode, AC output is overloaded or short-circuited and inverter has shutdown.	Check load connected to the output. Reduce load and restart the unit.
	Note: E03 will show for about 30 sec. After 30 sec, display will turn off and unit will shutdown completely.	
E04	When unit is in Battery/Inverter mode. internal temperature is too high and inverter has shutdown.	Turn unit off and wait for 15 minutes before restarting. Check if any object has blocked the airflow of the unit.
E05	When unit is in Battery/Inverter mode, input battery voltage is low and warning occurs.	Recharge battery as unit will shutdown shortly.
E06	When unit is in Battery/Inverter mode, AC output load connected has been sensed high and is close to shutdown limit.	Reduce AC load. Note: E06 occurs when AC Output power is close to 1850W for 2000W unit, 2800W for 3000W unit and 3800W for 4000W unit.
E07	When unit is in Battery/Inverter mode, internal temperature is high and is close to over-temperature shutdown limit.	Reduce load and check if any ventilation of the unit is blocked.
E10	When unit is in Bypass mode, Battery Charging voltage is too high.	Check battery setting. And check if there is any other DC power sources connected to the battery has high voltage.
E11	Bad Battery Classification (Bypass Mode) condition has not been solved. AC Charge! has shutdown.	-Check corrective action in E01 (Bypass Mode) and restart the charging process by removing and reconnecting the AC Input Source.
	Other conditions leading to Bad Battery Classification: Battery Voltage remains below 2/5/9.5V after 2/5/15 minutes of charging.	-Check if there is any heavy DC load connected to the battery as stated in E01 (Bypass mode). -Restart the charging process. -Change to a new battery.
E12	When unit is in Bypass mode, internal transfer switch temperature is high and shutdown occurs.	Reduce load and check if any ventilation of the unit is blocked.

Code	Condition	Corrective Action
E14	Remote display panel has communication error.	Check RJ12 cable connected between the main unit and the remote display panel.
E15	AC Back Feed to Unit AC Output.	Check AC Input and AC Output wiring.
E16	Internal Fault. Unit damage.	Consult Customer Service for assistance.
E17 (optional)	AC Input Current withdrawn from the unit is close to the set AC Circuit Breaker (Cbr) rating.	Reduce AC load. Check the AC Circuit Breaker (Cbr) rating match with the external AC Input Source Branch Breaker rating.
E18 (optional)	AC Input Current drawn by unit is beyond the current rating of the transfer switch (30A for 120V models; 16A for 230V models).	Reduce AC Load connected to unit.
E19	Battery temperature sensed by BTS is $>60^{\circ}\text{C}$. Battery charging cycle terminates.	Cool down the battery. Battery charging cycle will automatically resume when the temperature drops to below 50°C .
E20	Battery temperature sensed by BTS is $>55^{\circ}\text{C}$ and is close to battery temperature thermal shutdown.	Check battery and environmental temperature or add ventilation to the battery compartment.
E21	Battery temperature sensed by BTS is $<0^{\circ}\text{C}$. Battery charging cycle terminates.	Check battery and environmental temperature. The charging cycle will resume when temperature increases to $>5^{\circ}\text{C}$.

VII. Troubleshooting

To troubleshoot the unit, please note the error code displayed on the main unit and review 'Understanding the Error Codes' in section 5.

Problem	Possible Cause/Condition	Solution
No AC Output at AC Output Socket	The thermal breaker on the unit is tripped.	Reset the thermal breaker.
	With unit running from AC Input Source or shore power, the AC input Source is available but is outside the acceptance range.	Check AC Input Source. Operating range of AC Input is 95-139VAC. Unit Start-up AC Voltage is higher than 99V AC and below 132VAC.
	Unit is set to Inverter Off.	Check unit 'Int' setting.
	Check Error code on display. Inverter may be overloaded.	Reduce AC load. Inverter may be overloaded.
	DC over-voltage, under-voltage, or other shutdown type errors in addition to overload.	Check battery voltage.
	For 120V model, GFCI may have tripped.	Reset GFCI.
Charger did not supply charging current	Check charger setting. Charger may be set to Off.	Set Charger function 'CHG' to On.
	Unit had determined the battery is bad. See also description in Error code E01 (Bypass Mode) and E11.	Check battery and remove the DC load connected to the battery and restart the charger again.
	Battery is with BTS installed and it senses the battery temperature is high (E19).	Check battery temperature or environmental temperature. Battery charging cycle will resume when the battery cools down to acceptable level. See Understanding the Error Codes for more details.
	Battery is with BTS installed and it senses the battery temperature is too low to accept charge (E21).	Check battery temperature or environmental temperature. Battery charging cycle will resume when the battery temperature increases to acceptable temperature. See Understanding the Error Codes for more details.

VIII. Specification

UK

DE

12V Input Model

Specification	120VAC 12V Model
Running as Inverter	
AC Output Power	3000W
AC Output Current	25A
AC Surge Power (Peak)	6000W
AC Output Voltage/Frequency	12VAC/60HZ
AC Output Waveform	Sinewave (<3% THD)
Nominal DC Input Voltage	12.5 VDC
No Load battery draw(Inverter Mode)	<3.5 ADC
No Load Current(Power Saving Mode)	< 0.8 ADC
DC Input Voltage operating range	10.5-16.5 VDC
Under Voltage Alarm	11.0 - 12.5 VDC
Under Voltage Alarm Recovery	11.5-13.0 VDC
Under Voltage Shutdown	10.5-12.0 VDC
Under Voltage Recovery	11.5 - 13.0 VDC
Over Voltage Shutdown /Recovery	16.5 / 16.0 VDC
AC Transfer Switch	
Transfer Time	< 30 ms
Transfer Relay Rating	30A
AC Input Source Setting (Optional)	15, 20, 30A
AC Output Hardwire (Max.)	30A
AC Output Socket (Max.)	GFCI 20A
Display	
Inverter Mode	Battery Voltage, DC Current, AC Output Power
Charger Mode	Charging Voltage, Charging Current, AC Input Power
Remote PANEL Display	
Remote Display Port	RJ12
Inverter Mode	Battery Voltage, DC Current, AC Output Power
Charger Mode	Charging Voltage, Charging Current, AC Input Power
Running as Battery Charger	
Charging Voltage Range	13.8 - 14.8 VDC
Float Voltage Range	13.0 -14.0 VDC
Recharge Voltage Range	12.8 - 13.6 VDC

Bulk Charge Current Range	25 -100 A
Absorption -Float Current Range	2-20 A
Battery Type	Gel, Flooded, AGM, Lithium, Program, Power Supply
Charge Cycle Stages	Buk /Absorption / Float / Recharge
Maintenance Recharge Cycle	7 days
Power Factor Correction	>95%
Efficiency	>87%
Safety and Environmental	
120VAC Series	
Conformance	UL 458, CSA C22.2 No.107.2-01
EMI/EMC	FCC Part 15 Class B
Agency Markings	CETLUS
Operating Temperature	0°C to 40°C (32°F to 104°F)
Storage Temperature	-20°C to 60°C (-4°F to 140°F)
Relative Humidity	5-90% non-condensing
Operating Altitude	Up to 9,843ft (3000m) above sea level
Weight and Dimension	
Weight	16.3 lbs.(7.4 kg)
Dimension	17.0 x11.3 x4.3 inches (432.9x287 x110mm)

Note: Specifications are subject to change without notices

During the production and assembly of the Inverter-Charger, each unit undergoes several checks and tests. These are carried out with strict adherence to the established procedures. Each Inverter-Charger has a serial number allowing complete follow-up on the checks, according to the particular data for each device. For this reason it is very important never to remove the type plate which shows the serial number. The warranty for this equipment depends upon the strict application of the instructions appearing in this manual.

When the product is operated under normal conditions, we will provide Two Years of dependable service.

Two-year Limited Warranty

We warrant the inverter-charger to be free from the defects and/or failures specified below for a period not exceeding two years from the date of sale to the original customer.

- * Defects and/or failures due to manufacturing
- * Defects and/or failures due to materials
- * Non-conformity to specifications due to faulty manufacturing and/or inspection processes. If the inverter-charger fails to conform to this warranty, we will repair or replace the inverter-charger at our sole option.

Warranty Exclusions

1. No claim based on the limited warranty will be brought after the applicable warranty period. Any delivery of additional inverter or the repair or replacement of the inverter would not extend the original terms of this limited Warranty.

2. This Limited Warranty shall not cover defects and/or failures of the inverter from the following causes even though such defects and/or failures are discovered within the applicable warranty period.

a) Defects and/or failures caused by devices and/or parts other than the inverter or by mounting methods of such devices and/or parts.

b) Defects and/or failures caused by defective wiring, installation, or handling.

c) Defects and/or failures caused by installations not in conformance with inverter specifications, installation manuals, operation manuals, or labels attached to the inverter.

d) Defects and/or failures caused by unauthorized maintenance, operation or modification.

e) Defects and/or failures caused by removal from the original place of installment.

f) Defects and/or failures caused by repair not in accordance with our instructions.

g) Defects and/or failures caused by in appropriate handling during transportation or storage.

h) Defects and/or failures caused by external accidents such as fire, explosion, and civil disorder.

i) Defects and/or failures caused by natural forces, acts of God or force majeure events and other unforeseen hurricanes, tornadoes, volcanic action, floods, tsunamis, lightning, snow dangers, etc

j) Defects and/or failures caused by smoke and/or other pollution, salt damage, acid rain, etc.

We reserve the rights to make any modifications to the product without prior notification.

VIII. Technical Support

UK

DE

1) Customer service telephone numbers:

Tel(DE): +49 6175-6514-999

Tel(US): 1-866-939-8222

Tel(UK): +447-553-406988

2) Company address: USA/Germany



Address(US): 4411 East State Hwy D Suite C Springfield, Missouri 65809



Address(DE): ECO-Worthy Europe GmbH Otto-Hahn-Str. 20
61381 Friedrichsdorf - Köppern Germany

3) Customer service email:



E-mail: customer.service@eco-worthy.com

4) Official website address:



Web: <https://www.eco-worthy.com/>

5) Official social media:



Facebook: <https://www.facebook.com/ecoworthy.store/>



Youtube: @ecoworthy



Tiktok: https://www.tiktok.com/@eco_worthy

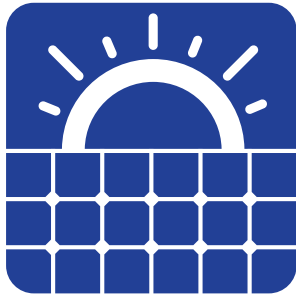

ECO-WORTHY