

Sears

*owners
manual*

**MODEL NO.
113.242502**

Serial
Number _____

Model and serial
number may be found
at the rear
of the base.

You should record both
model and serial number
in a safe place for
future use.

CAUTION:

Read **GENERAL**
and **ADDITIONAL**
SAFETY
INSTRUCTIONS
carefully

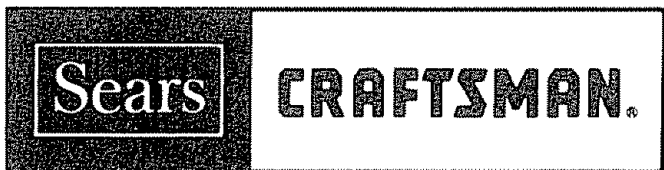
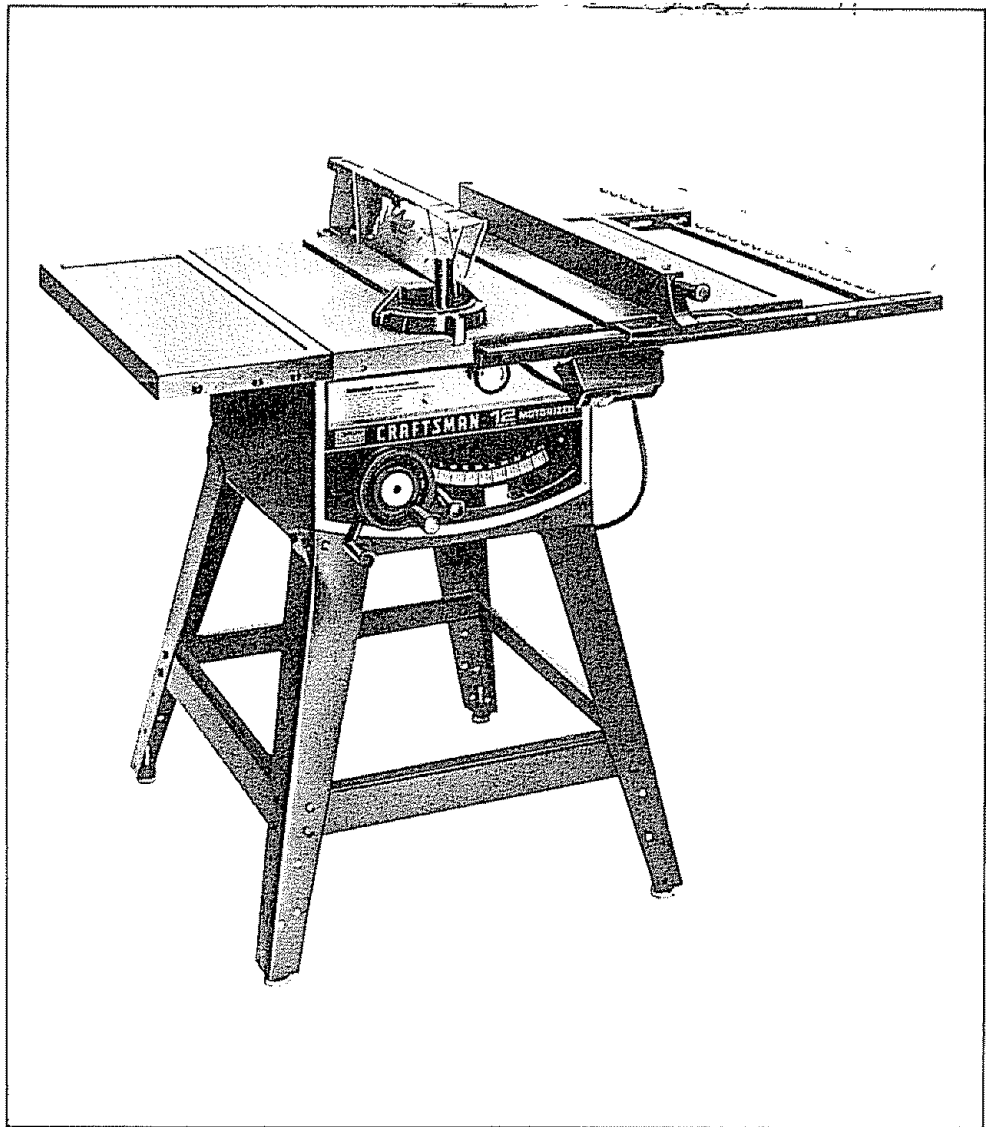

***12-INCH MOTORIZED
TABLE SAW***

- *assembly*
- *operating*
- *repair parts*

Sold by SEARS, ROEBUCK AND CO., Chicago, IL. 60684 U.S.A.

FULL ONE YEAR WARRANTY ON CRAFTSMAN TABLE SAWS

If within one year from the date of purchase, this Craftsman Table Saw fails due to a defect in material or workmanship, Sears will repair it, free of charge.

WARRANTY SERVICE IS AVAILABLE BY SIMPLY CONTACTING THE NEAREST SEARS STORE OR SERVICE CENTER THROUGHOUT THE UNITED STATES.

This warranty gives you specific legal rights, and you may also have other rights which vary from state to state.

SEARS, ROEBUCK AND CO., Sears Tower, BSC 41-3, Chicago, IL 60684

general safety instructions for power tools

1. KNOW YOUR POWER TOOL

Read and understand the owner's manual and labels affixed to the tool. Learn its application and limitations as well as the specific potential hazards peculiar to this tool.

2. GROUND ALL TOOLS

This tool is equipped with an approved 3-conductor cord and a 3-prong grounding type plug to fit the proper grounding type receptacle. The green conductor in the cord is the grounding wire. Never connect the green wire to a live terminal.

3. KEEP GUARDS IN PLACE

in working order, and in proper adjustment and alignment.

4. REMOVE ADJUSTING KEYS AND WRENCHES

Form habit of checking to see that keys and adjusting wrenches are removed from tool before turning it on.

5. KEEP WORK AREA CLEAN

Cluttered areas and benches invite accidents. Floor must not be slippery due to wax or sawdust.

6. AVOID DANGEROUS ENVIRONMENT

Don't use power tools in damp or wet locations or expose them to rain. Keep work area well lighted. Provide adequate surrounding work space.

7. KEEP CHILDREN AWAY

All visitors should be kept a safe distance from work area.

8. MAKE WORKSHOP KID-PROOF

— with padlocks, master switches, or by removing starter keys.

9. DON'T FORCE TOOL

It will do the job better and safer at the rate for which it was designed.

10. USE RIGHT TOOL

Don't force tool or attachment to do a job it was not designed for.

11. WEAR PROPER APPAREL

Do not wear loose clothing, gloves, neckties or jewelry (rings, wrist watches) to get caught in moving parts. Nonslip footwear is recommended. Wear protective hair covering to contain long hair. Roll long sleeves above the elbow.

12. USE SAFETY GOGGLES (Head Protection)

Wear Safety goggles (must comply with ANS Z87.1) at all times. Everyday eyeglasses only have impact resistant lenses, they are NOT safety glasses. Also, use face or dust mask if cutting operation is dusty, and ear

protectors (plugs or muffs) during extended periods of operation.

13. SECURE WORK

Use clamps or a vise to hold work when practical. It's safer than using your hand, frees both hands to operate tool.

14. DON'T OVERREACH

Keep proper footing and balance at all times.

15. MAINTAIN TOOLS WITH CARE

Keep tools sharp and clean for best and safest performance. Follow instructions for lubricating and changing accessories.

16. DISCONNECT TOOLS

before servicing; when changing accessories such as blades, bits, cutters, etc.

17. AVOID ACCIDENTAL STARTING

Make sure switch is in "OFF" position before plugging in.

18. USE RECOMMENDED ACCESSORIES

Consult the owner's manual for recommended accessories. Follow the instructions that accompany the accessories. The use of improper accessories may cause hazards.

19. NEVER STAND ON TOOL

Serious injury could occur if the tool is tipped or if the cutting tool is accidentally contacted.

Do not store materials above or near the tool such that it is necessary to stand on the tool to reach them.

20. CHECK DAMAGED PARTS

Before further use of the tool, a guard or other part that is damaged should be carefully checked to ensure that it will operate properly and perform its intended function. Check for alignment of moving parts, binding of moving parts, breakage of parts, mounting, and any other conditions that may affect its operation. A guard or other part that is damaged should be properly repaired or replaced.

21. DIRECTION OF FEED

Feed work into a blade or cutter against the direction of rotation of the blade or cutter only.

22. NEVER LEAVE TOOL RUNNING UNATTENDED

Turn power off. Don't leave tool until it comes to a complete stop.

ADDITIONAL SAFETY INSTRUCTIONS FOR TABLE SAWS

WARNING: FOR YOUR OWN SAFETY, DO NOT OPERATE YOUR SAW UNTIL IT IS COMPLETELY ASSEMBLED AND INSTALLED ACCORDING TO THE INSTRUCTIONS ... AND UNTIL YOU HAVE READ AND UNDERSTOOD THE FOLLOWING.

1. GENERAL SAFETY INSTRUCTIONS FOR POWER TOOLS ... SEE PAGE 2
2. GETTING TO KNOW YOUR SAW ... SEE PAGE 15
3. BASIC SAW OPERATION ... SEE PAGE 17
4. ADJUSTMENTS ... SEE PAGE 23
5. MAINTENANCE ... SEE PAGE 26
6. STABILITY OF SAW

If there is any tendency for the saw to tip over or move during certain cutting operations such as cutting extremely large heavy panels or long heavy boards, the saw should be bolted down.

If you attach any kind of table extensions over 24" wide to either end of the saw, make sure you either bolt the saw to the bench or floor as appropriate, or support the outer end of the extension from the bench or floor, as appropriate.

7. LOCATION

The saw should be positioned so neither the operator nor a casual observer is forced to stand in line with the saw blade

8. KICKBACKS

A "KICKBACK" occurs during a rip-type operation when a part or all of the workpiece is thrown back violently toward the operator.

Keep your face and body to one side of the sawblade, out of line with a possible "Kickback "

Kickbacks — and possible injury from them — can usually be avoided by:

- A. Maintaining the rip fence parallel to the sawblade
- B. Keeping the sawblade sharp. Replacing antikickback pawls when points become dull.
- C. Keeping sawblade guard, spreader, and antikickback pawls in place and operating properly. The spreader must be in alignment with the sawblade and the pawls must stop a kickback once it has started. Check their action before ripping.
- D. NOT ripping work that is twisted or warped or does not have a straight edge to guide along the rip fence
- E. NOT releasing work until you have pushed it all the way past the sawblade.
- F. Using a "PUSH STICK" (See Page 16) for ripping widths of 2 to 6 in., and an auxiliary fence and push block for ripping widths narrower than 2 in. (See "Basic Saw Operation Using The Rip Fence" section.)
- G. NOT confining the cut-off piece when ripping or crosscutting.
- H. When ripping apply the feed force to the section of the workpiece between the saw blade and the rip fence

9. PROTECTION: EYES, HANDS, FACE, EARS, BODY

- A. If any part of your saw is malfunctioning, has been damaged or broken such as the motor switch, or other operating control, a safety device or the power cord cease operating immediately until the particular part is properly repaired or replaced
- B. Wear safety goggles that comply with ANSI Z87.1, and a face shield if operation is dusty. Wear ear plugs or muffs during extended periods of operation.
- C. Small loose pieces of wood or other objects that contact the rear of the revolving blade can be thrown back at the operator at excessive speed. This can usually be avoided by keeping the guard and

spreader in place for all "THRU-SAWING" operations (sawing entirely thru the work) AND by removing all loose pieces from the table with a long stick of wood IMMEDIATELY after they are cut off.

- D. Use extra caution when the guard assembly is removed for resawing, dadoing, rabbeting, or molding — replace the guard as soon as that operation is completed
- E. For rip or rip-type cuts, the following end of a workpiece to which a push stick or push board is applied must be square (perpendicular to the fence) in order that feed pressure applied to the workpiece by the push stick or block does not cause the workpiece to come away from the fence, and possibly cause a kickback.
- F. During rip and rip type cuts, the workpiece must be held down on the table and against the fence with a push stick, push block, or featherboards. A featherboard is made of solid lumber per sketch.

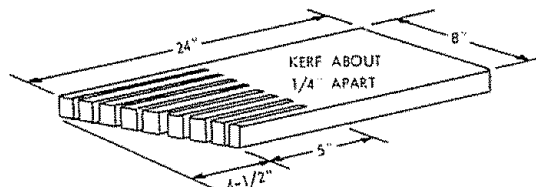

- G. NEVER turn the saw "ON" before clearing the table of all tools, wood scraps, etc., except the workpiece and related feed or support devices for the operation planned.
- H. NEVER place your face or body in line with the cutting tool.
- I. NEVER place your fingers or hands in the path of the sawblade or other cutting tool.
- J. NEVER reach in back of the cutting tool with either hand to hold down or support the workpiece, remove wood scraps, or for any other reason. Avoid awkward operations and hand positions where a sudden slip could cause fingers or hand to move into a sawblade or other cutting tool.
- K. DO NOT perform layout, assembly, or setup work on the table while the cutting tool is rotating.
- L. DO NOT perform any operation "FREEHAND" — always use either the rip or the miter gauge to position and guide the work.
- M. NEVER use the rip fence when crosscutting or the miter gauge when ripping. DO NOT use the rip fence as a length stop.
NEVER hold onto or touch the "free end" of the workpiece or a "free piece" that is cut off, while power is "ON" and/or the sawblade is rotating.
- N. Shut "OFF" the saw and disconnect the power cord when removing the table insert, changing the cutting tool, removing or replacing the blade guard, or making adjustments.
- O. Provide adequate support to the rear and sides of the saw table for wider or long workpieces.
- P. Plastic and composition (like hardboard) materials may be cut on your saw. However, since these are usually quite hard and slippery, the antikickback pawls may not stop a kickback.
Therefore, be especially attentive to following proper set-up and cutting procedures for ripping. Do not stand, or permit anyone else to stand, in line with a potential kickback.
- Q. If you stall or jam the sawblade in the workpiece, turn saw "OFF", remove the workpiece from the sawblade, and check to see if the sawblade is parallel to the miter gauge grooves and if the

spreader is in proper alignment with the sawblade. If ripping at the time, check to see if the rip fence is parallel with the sawblade. Readjust as indicated.

- R. DO NOT remove small pieces of cut-off material that may become trapped inside the blade guard while the saw is running. This could endanger your hands or cause a kickback. Turn saw "OFF" and wait until blade stops.
- S. Use extra care when ripping wood that has a twisted grain or is twisted or bowed — it may rock on the table and/or pinch the sawblade.

10. KNOW YOUR CUTTING TOOLS

- A. Dull, gummy, or improperly sharpened or set cutting tools can cause material to stick, jam, stall the saw, or kickback at the operator. Minimize potential injury by proper cutting tool and machine maintenance. NEVER ATTEMPT TO FREE A STALLED SAWBLADE WITHOUT FIRST TURNING THE SAW OFF.
- B. Never use grinding wheels, abrasive cut-off wheels, friction wheels (metal slitting blades) wire wheels or buffing wheels.

11. USE ONLY ACCESSORIES DESIGNED FOR THIS SAW.

- 12. Crosscutting operations are more conveniently worked and with greater safety if an auxiliary wood facing is attached to the miter gauge using the holes provided. However, the facing must not interfere with the proper functioning of the sawblade guard.
- 13. Make sure the top of the arbor or cutting tool rotates toward you when standing in normal operating position. Also make sure the cutting tool, arbor collars and arbor nut are installed properly. Keep the cutting tool as low as possible for the operation being performed. Keep all guards in place whenever possible.
- 14. Do not use any blade or other cutting tool marked for an operating speed less than 3450 RPM. Never use a cutting tool larger in diameter than the diameter for which the saw was designed. For greatest safety and efficiency when ripping, use the maximum diameter blade for which the saw is designed, since under these conditions the spreader is nearest the blade.

- 15. Adjust table inserts flush with the table top. NEVER Operate the saw unless the proper insert is installed.
- 16. Never feed material into the cutting tool from the rear of the saw. An accident and serious injury could result.
- 17. Always maintain control of the workpiece — DO NOT "let go" of the workpiece until the cutting tool has come to a stop.
- 18. IF YOUR SAW MAKES AN UNFAMILIAR NOISE OR IF IT VIBRATES EXCESSIVELY CEASE OPERATING IMMEDIATELY UNTIL THE SOURCE HAS BEEN LOCATED AND THE PROBLEM CORRECTED.
- 19. If any part of this table saw is missing or should break, bend or fail in any way, or any electrical component fail to perform properly, shut off power switch, remove cord from power supply and replace damaged, missing and/or failed parts before resuming operation.
- 20. THINK SAFETY. Safety is a combination of operator common sense and alertness at all times when the saw is being used.
- 21. NOTE AND FOLLOW SAFETY INSTRUCTIONS THAT APPEAR ON THE FRONT OF YOUR SAW.

DANGER
FOR YOUR OWN SAFETY
READ AND UNDERSTAND OWNER'S MANUAL
BEFORE OPERATING MACHINE.
1. WEAR SAFETY GOGGLES PER ANSI Z87.1 AT ALL TIMES
2. USE SAW BLADE GUARD FOR THRU SAWING
3. KEEP HANDS OUT OF PATH OF SAWBLADE
4. USE A "PUSH STICK" WHEN REQUIRED
5. KNOW HOW TO AVOID "KICKBACKS"
6. DO NOT PERFORM OPERATIONS "FREEHAND"
7. NEVER REACH AROUND OR OVER SAW BLADE

22. WARNING: DO NOT ALLOW FAMILIARITY (GAINED FROM FREQUENT USE OF YOUR SAW) TO BECOME COMMONPLACE. - ALWAYS REMEMBER THAT A CARELESS FRACTION OF A SECOND IS SUFFICIENT TO INFLICT SEVERE INJURY.

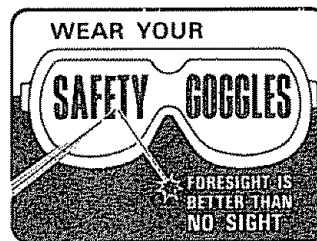

The operation of any power tool can result in foreign objects being thrown into the eyes, which can result in severe eye damage. Always wear safety goggles complying with ANSI Z87.1 (shown on Package) before commencing power tool operation. Safety Goggles are available at Sears retail or catalog stores.

MOTOR SPECIFICATIONS AND ELECTRICAL REQUIREMENTS

MOTOR SPECIFICATIONS

The AC motor used in this saw is a capacitor start, non-reversible type, with the following specifications:

Voltage	240
Amperes	7
Hertz	60
Phase	Single
RPM	3450
Rotation (viewed from sawblade end)	Counterclockwise

MOTOR SAFETY PROTECTION

The saw motor is equipped with a manual-reset thermal overload protector, designed to open the power line circuit when the motor temperature exceeds a safe value.

- 1. If motor is overloaded and overload protector is actuated (stopping motor) BE POSITIVE you push switch "OFF" immediately and allow the motor to cool before attempting to reset the protector. Since the protector is near the sawblade, the switch must not be turned "ON" until after you have reset the protector.
- 2. If the red button will not snap into place immediately,

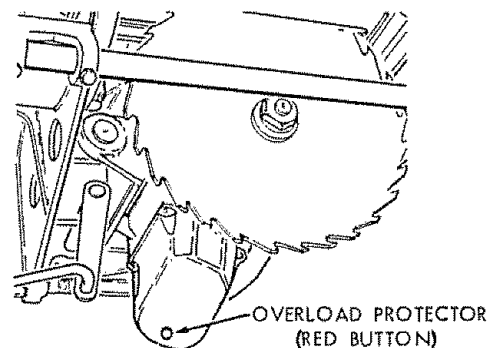

the motor is still too hot and must be allowed to cool for a while longer.

- 3. As soon as the red button will snap into running position, the saw may be started and operated normally by moving the saw switch lever to the "ON" position.
- 4. Frequent opening of fuses or circuit breakers may result if motor is overloaded, or if the motor circuit is fused with a fuse of greater capacity without consulting the power company.



- Although the motor is designed for operation on the voltage and frequency specified on motor nameplate, normal loads will be handled safely on voltages not more than 10% above or below the nameplate voltage. Heavy loads, however, require that voltage at motor terminals be not less than the voltage specified on nameplate.
- Most motor troubles may be traced to loose or incorrect connections, overloading, reduced input voltage (which results when small size wires are used in the supply circuit) or when the supply circuit is extremely long. Always check connections, load and supply circuit when the motor fails to perform satisfactorily. Check wire sizes and lengths with the table in the next paragraph. Replace or repair damaged or worn cord immediately.

CONNECTING TO POWER SOURCE OUTLET

This saw must be grounded while in use to protect the operator from electrical shock.

If power cord is worn or cut, or damaged in any way, have it replaced immediately.

CAUTION: This saw is wired for operation on 240 volts only. Connect to a 15 ampere branch circuit protected by a 15 ampere time delay or circuit saver fuse or circuit breaker.

WARNING: Do not permit fingers to contact the terminals of power or motor plugs when installing or removing the plug to or from a live power source. Hold the plug as shown.

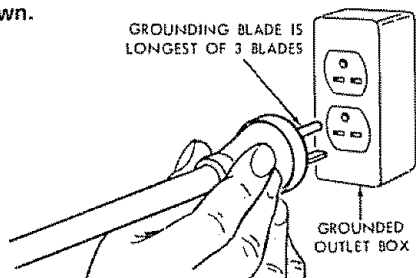

NO ADAPTER IS AVAILABLE FOR THIS TYPE PLUG

IF YOU ARE NOT SURE THAT YOUR OUTLET IS

PROPERLY GROUNDED, HAVE IT CHECKED BY A QUALIFIED ELECTRICIAN.

WARNING: IF NOT PROPERLY GROUNDED THIS POWER TOOL CAN INCUR THE POTENTIAL HAZARD OF ELECTRICAL SHOCK, PARTICULARLY WHEN USED IN DAMP LOCATIONS, IN PROXIMITY TO PLUMBING, OR OUT OF DOORS. IF AN ELECTRICAL SHOCK OCCURS THERE IS THE POTENTIAL OF A SECONDARY HAZARD SUCH AS YOUR HANDS CONTACTING THE SAWBLADE.

This power tool is equipped with a 3-conductor cord and grounding type plug which has a grounding prong, approved by Underwriters' Laboratories and the Canadian Standards Association. The ground conductor has a green lug and is attached to the tool housing at one end and to the ground prong in the attachment plug at the other end.

The use of any extension cord will cause some loss of power. To keep this to a minimum and to prevent over-heating or motor burn-out, use the table below to determine the minimum wire size (A.W.G.) extension cord. Use only 3 wire extension cords which have 3 prong grounding type lugs and 3-pole receptacles which accept the tools plug.

Extension Cord Length	Wire Size A.W.G.
Up to 100 ft.	14
100 ft. to 200 ft.	12
200 ft. to 400 ft.	8

NOTE: For circuits of greater length, the wire size must be increased proportionately in order to deliver ample voltage to the saw motor.

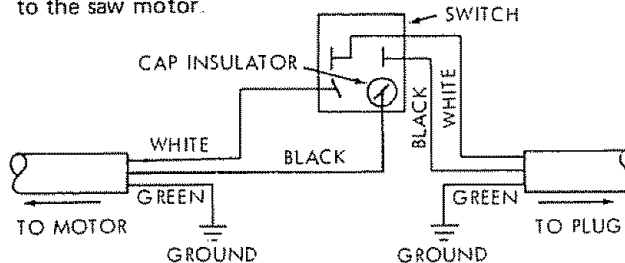

CONTENTS

WARRANTY	2	Exacti-Cut	16
GENERAL SAFETY INSTRUCTIONS FOR POWER TOOLS	2	BASIC SAW OPERATION USING THE MITER GAUGE	17
ADDITIONAL SAFETY INSTRUCTIONS FOR TABLE SAWS	3	Work Helpers	17
MOTOR SPECIFICATIONS AND ELECTRICAL REQUIREMENTS	4	Crosscutting	18
UNPACKING AND CHECKING CONTENTS	6	Repetitive Cutting	18
Tools Needed	6	Miter Cutting	19
List of Loose Parts	6	Bevel Crosscutting	19
ASSEMBLY	7	Compound Miter Cutting	19
Attaching Legs	7	BASIC SAW OPERATION USING THE RIP FENCE	20
Checking Table Insert	7	Ripping	20
Checking Blade Squareness to Table	8	Bevel Ripping	20
Attaching and Assembling Table Extensions	8	Ploughing and Molding	21
Installing Rip Fence Guide Bars	9	Resawing	22
Aligning Rip Fence	11	Cutting Panels	22
Adjusting Rip Scale Pointer	12	Rabbeting	22
Installing Blade Guard	12	Using Featherboards	23
GETTING TO KNOW YOUR SAW	14	ADJUSTMENTS	23
On-Off Switch	14	Miter Gauge	23
Elevation Handwheel	15	Heeling Adjustment or Parallelism of Sawblade to Miter Gauge Groove	24
Elevation Lock	15	Blade Tilt, or Squareness of Blade to Table	25
Tilt Crank	15	Elevation Lock	26
Rip Fence	15	MAINTENANCE	26
Miter Gauge	15	LUBRICATION	27
Blade Guard	15	RECOMMENDED ACCESSORIES	27
Table Insert	15	TROUBLE SHOOTING	28
Removing and Installing Sawblade	16	REPAIR PARTS	30

UNPACKING AND CHECKING CONTENTS

TOOLS NEEDED

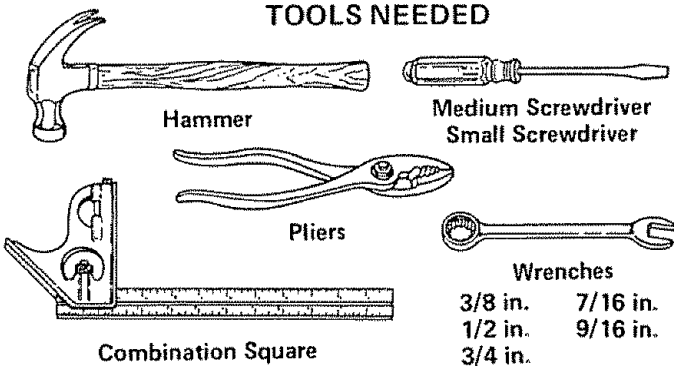

COMBINATION SQUARE MUST BE TRUE.

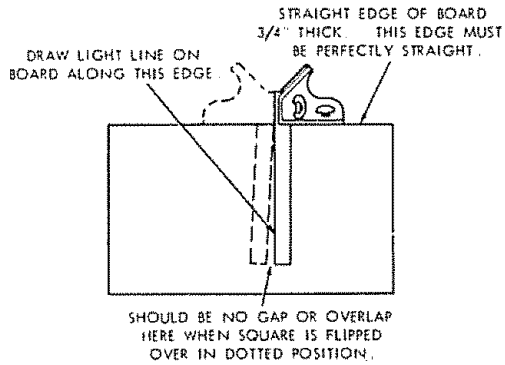

Model 113.242502 Motorized Table Saw is shipped complete in one carton including Two Table Extensions and Steel Legs.

Separate all parts from packing materials and check each one with the illustration and the list of Loose Parts to make certain all items are accounted for, before discarding any packing material.

If any parts are missing, do not attempt to assemble the table saw, plug in the power cord or turn the switch on until the missing parts are obtained and are installed correctly.

Remove the protective oil that is applied to the table top and edges of the table. Use any ordinary household type grease and spot remover.

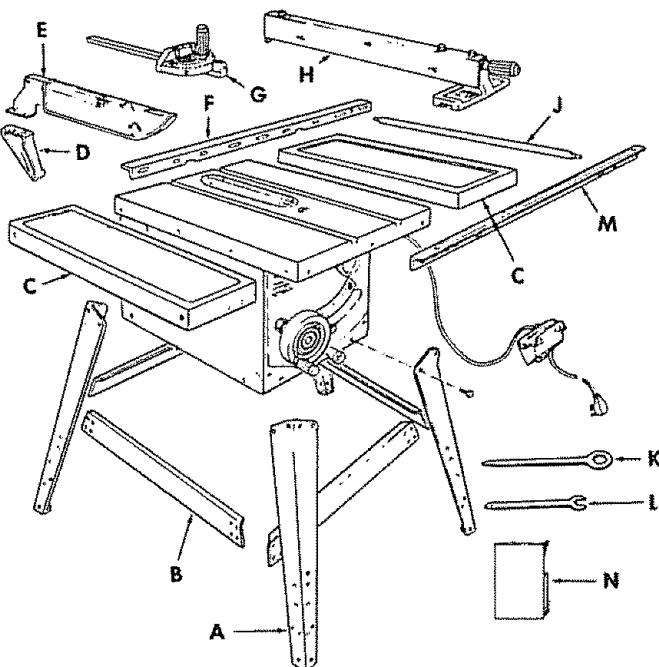

CAUTION: Never use gasoline, naphtha or similar highly volatile solvents.

Apply a coat of automobile wax to the table.

Wipe all parts thoroughly with a clean, dry cloth.

WARNING: FOR YOUR OWN SAFETY, NEVER CONNECT PLUG TO POWER SOURCE OUTLET UNTIL ALL ASSEMBLY STEPS ARE COMPLETE, AND YOU HAVE READ AND UNDERSTAND THE SAFETY AND OPERATIONAL INSTRUCTIONS.

LIST OF LOOSE PARTS

Item	Part Name	Qty.
A	Leg	4
B	Stiffener	4
C	Table Extension	2
D	Spreader Support	1
E	Blade Guard and Spreader	1
F	Fence Guide Bar (Rear)	1
G	Miter Gauge	1
H	Rip Fence	1
J	Guide Bar Rod	1
K	Arbor Nut Wrench	1
L	Arbor Wrench	1
M	Fence Guide Bar with Rip Scale (Front)	1
N	Owners Manual	1
	Pkg. of Miscellaneous Small Parts No. 62746	
	Consisting of the Following:	
O	Setscrew Wrench, 3/32 in.	1
O	Setscrew Wrench, 1/8 in.	1
O	Setscrew Wrench, 5/32 in.	1
O	Setscrew Wrench, 3/16 in.	1
P	Switch Key	1
Q	Self-Threading Nut	2
R	Hex Head Screw, 5/16-18 x 1-3/4 in. long	2
R	Hex Head Screw, 5/16-18 x 1 in. long	2
R	Hex Head Screw, 5/16-18 x 5/8 in. long	16
R	Hex Head Screw, 1/4-20 x 1/2 in. long	16
R	Hex Head Screw, 1/4-20 x 5/8 in. long	2
S	Hex Nut, 5/16-18	
	(approx. dia. of hole 5/16 in.)	20
S	Hex Nut, 1/4-20	
	(approx. dia. of hole 1/4 in.)	18
S	Hex Nut, 1/2-13	
	(approx. dia. of hole 1/2 in.)	8
T	Lockwasher, 5/16 in. External Type	
	(approx. dia. of hole 5/16 in.)	20
T	Lockwasher, 1/4 in. External Type	
	(approx. dia. of hole 1/4 in.)	18
U	Guide Bar Spacer	2
V	Thumbscrew, 5/16-18 x 1 in. long	1
W	Leveling Foot	4
	2 Pkgs. of Miscellaneous Small Parts No. 62745	
	for Table Extensions consisting of the Following:	
	Corner Support Bracket	4
	Corner Stiffener Bracket	4
	Truss Hd. Screw, 1/4-20 x 1 in. long	16
R	Hex Hd. Screw, 5/16-18 x 1-1/4 in. long	8
S	Hex Nut, 1/4-20	
	(approx. dia. of hole 1/4 in.)	16
S	Hex Nut, 5/16-18	
	(approx. dia. of hole 5/16 in.)	8
T	Lockwasher, 1/4 in. External Type	
	(approx. dia. of hole 1/4 in.)	16
T	Lockwasher, 5/16 in. External Type	
	(approx. dia. of hole 5/16 in.)	8
X	Flat Washer, 11/32	8

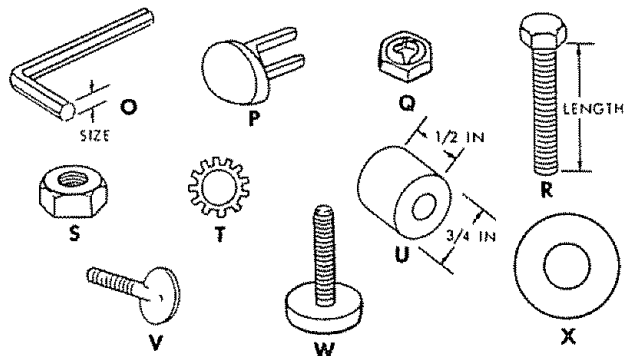

ASSEMBLY

ATTACHING LEGS

1. Turn the saw upside down

NOTE: DO NOT LAY IT ON THE FLOOR AS THIS MAY SCRATCH THE TABLE SURFACE. PLACE IT ON STRIPS OF WOOD OR PARTS OF THE PACKING MATERIAL.

2. From among the loose parts, find the following hardware:

16 Hex. Head Screws, 5/16–18 x 5/8 in. long
 16 Hex. Nuts, 5/16–18 (approx. dia. of hole, 5/16 in.)
 16 Hex. Head Screws, 1/4 in.–20 x 1/2 in. long
 16 Hex. Nuts, 1/4–20 (approx. dia. of hole, 1/4 in.)
 8 Hex. Nuts, 1/2–13 (approx. dia. of hole, 1/2 in.)
 4 Leveling Feet
 16 Lockwashers, 1/4 in. External Type (approx. dia. of hole, 1/4 in.)
 16 Lockwashers, 5/16 in. External Type (approx. dia. of hole, 5/16 in.)

NOTE: The four stiffeners are identical. BE SURE TO ATTACH THE SIDE STIFFENERS USING THE OUTER HOLES ... ATTACH END STIFFENERS USING INNER HOLES.

3. Insert screws through legs then through stiffeners. Install lockwashers and nuts. **DO NOT TIGHTEN.**
4. After all screws, washers and nuts are installed, tighten all nuts.
5. Install leveling feet.
6. Place saw in upright position.

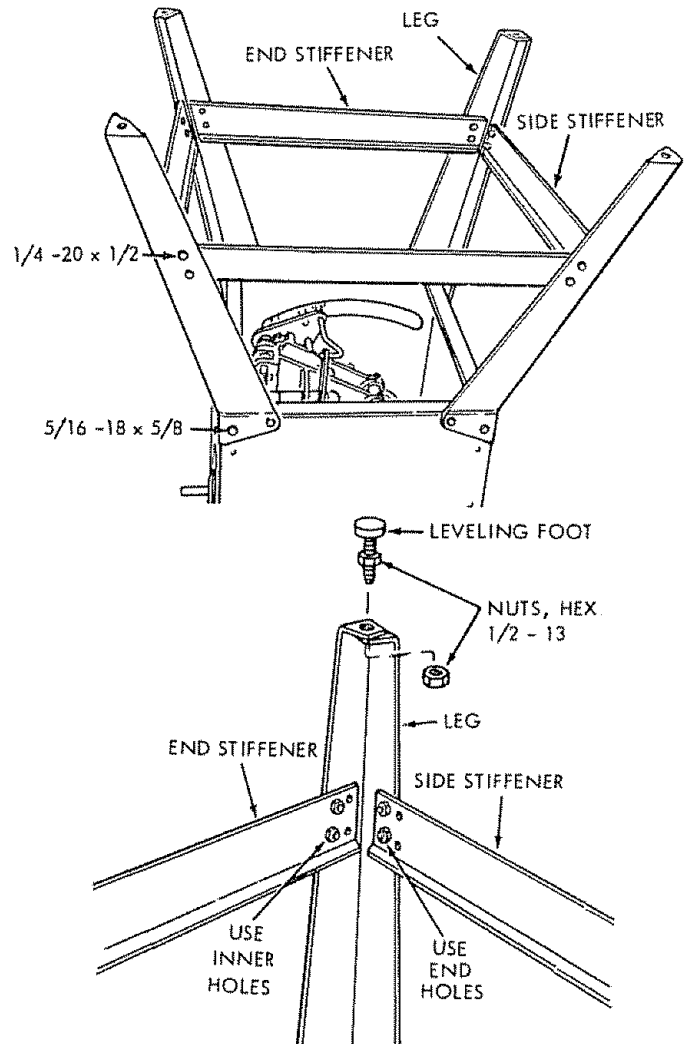

BEFORE PROCEEDING WITH THE ASSEMBLY, THE TABLE INSERT, BLADE SQUARENESS, AND BLADE PARALLELISM MUST BE CHECKED AT THIS TIME.

CHECKING TABLE INSERT

1. Insert should be flush with table top. Check as shown. Loosen flat head screw that holds insert and adjust the four set screws as necessary. Tighten flat head screw. Do not tighten screw to the point where it deflects the insert.

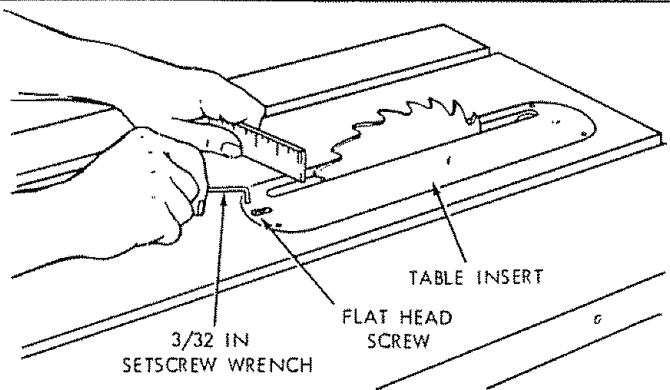

2. To remove insert.
 - A) Loosen Screw
 - B) Lift insert from front end, and pull toward front of saw.
3. To replace insert.

Place insert into insert opening in table and push toward rear of saw to engage spring clip and until keyslot in insert will drop over screw. Tighten screw.

Do not tighten screw to the point where it will deflect the insert.

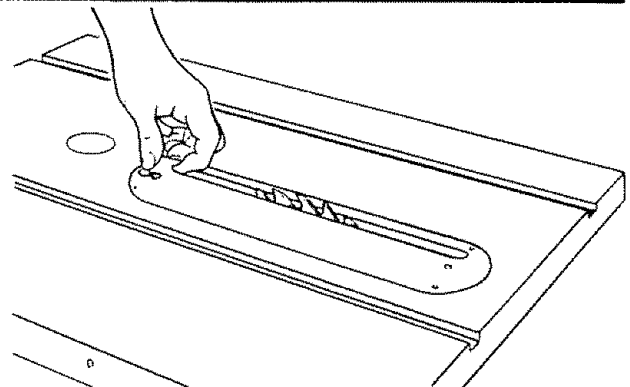

CHECKING BLADE SQUARENESS TO TABLE

1. Loosen ELEVATION LOCK by pulling KNOB forward.
2. Turn ELEVATION handwheel clockwise until blade is as high up as it will go.

IMPORTANT: BLADE must be SQUARE (90°) to TABLE, in order to ALIGN rip fence.

3. Check for BLADE SQUARENESS . . . if blade is not square to table, adjust it at this time.

NOTE: The combination square must be "true" — see start of "Unpacking and Checking Contents" section on page 6 for checking method.

Refer to "BLADE TILT, OR SQUARENESS OF BLADE TO TABLE" adjustments on page 24.

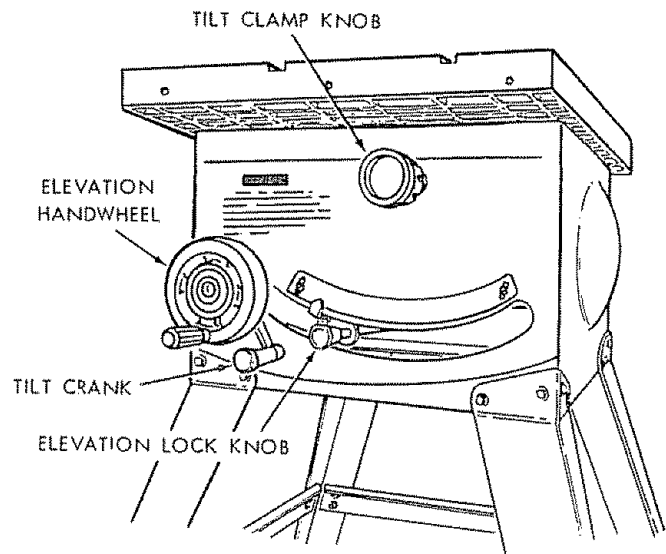
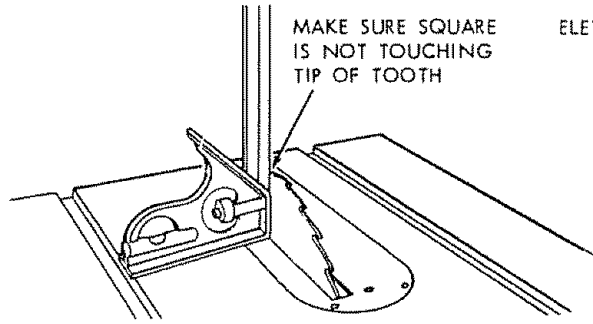

SAWBLADE PARALLELISM

The sawblade must be parallel to the miter gauge slots and the rip fence in order to prevent heeling. To check for parallelism:

1. Raise blade all the way up.
2. Mark an "x" on one of the teeth which is SET (bent) to the LEFT.
3. Place the head of a combination square in the GROOVE . . . adjust blade of square so that it just touches the tip of the MARKED tooth.
4. Move square to REAR, rotate blade to see if MARKED tooth again touches blade of square.
5. If tooth touches square the same amount at FRONT and REAR . . . sawblade is PARALLEL to MITER GAUGE GROOVE.

If tooth does not touch front and rear, adjust immediately

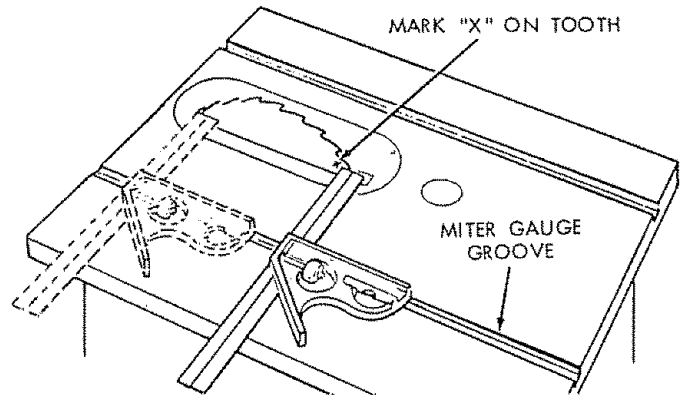

according to instructions on pg. 23 under heading: "HEELING ADJUSTMENT: PARALLELISM OF SAWBLADE TO MITER GAUGE GROOVE."

ATTACHING AND ASSEMBLING TABLE EXTENSIONS

1. From among the loose parts find the following hardware.

- 4 Corner Support Brackets
- 4 Corner Stiffener Brackets
- 16 Truss Hd. Screws 1/4-20 x 1
- 16 Ext. Lockwashers 1/4
- 16 Hex Nut 1/4-20
- 8 Hex Hd. Screws 5/16-18 x 1-1/4
- 8 Ext. Lockwasher 5/16
- 8 Hex Nut 5/16-18
- 8 Flat Washer 11/32

Assemble brackets with hardware listed above as shown. Insert 5/16-18 x 1-1/4 in. long screws through holes in EXTENSION then through table. Install flat washer, lockwashers and screw on the nuts . . . DO NOT TIGHTEN.

Align front edge of extension with front edge of saw table. Pull Extension UPWARDS above table surface . . . SLIGHTLY TIGHTEN SCREWS using 1/2 in. wrench.

Using small block of hardwood and hammer, tap extension DOWNWARDS at front, center & rear, until it is EVEN with table surface . . . TIGHTEN SCREWS.

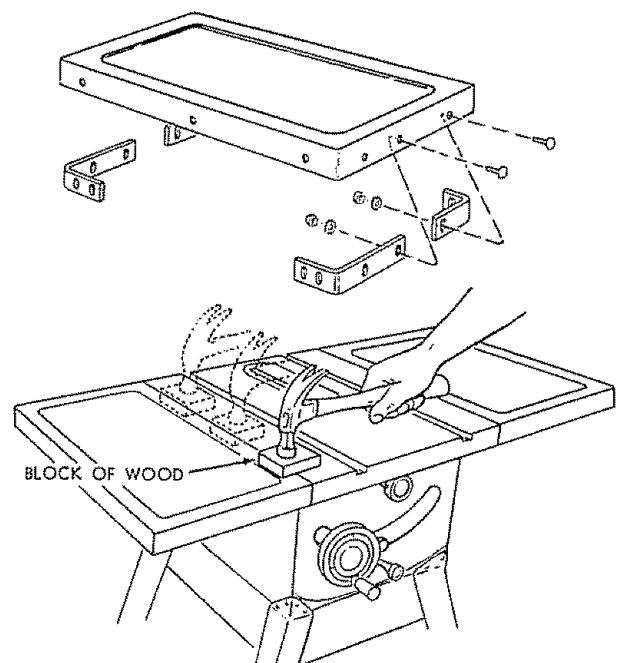

Lay REAR FENCE GUIDE BAR on table to act as a straightedge. If outer edge of extension is higher or lower than table surface;

- A. Slightly loosen nuts holding bracket to extension using 7/16 in. wrench.
- B. Move end of extension up or down until outer edge is even with table surface ... check with GUIDE BAR ... tighten nuts.
- C. Recheck INNER edge of extension to make sure it has not moved ... readjust, if necessary.

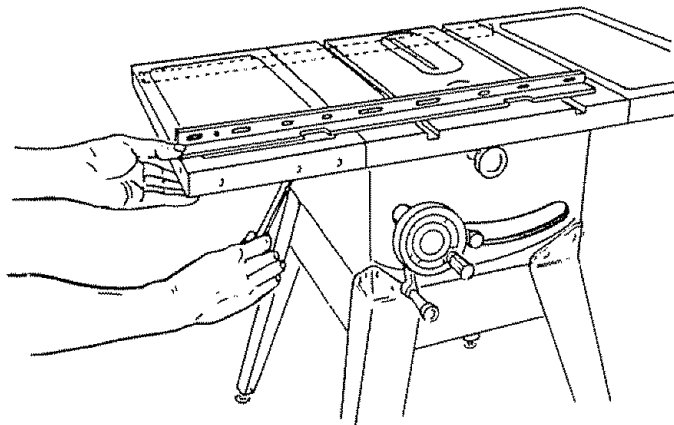

INSTALLING RIP FENCE GUIDE BARS

1. From among the loose parts find the following hardware:
 - 2 Hex. Head Screws, 5/16–18 x 1-3/4 in. long
 - 2 Hex. Head Screws, 5/16–18 x 1 in. long
 - 4 Hex. Nuts, 5/16–18 (approx. dia. of hole 5/16 in.)
 - 4 External Lockwashers, 5/16 in. (approx. dia. of hole 5/16 in.)
 - 2 Spacers, 3/4 in. dia. x 1/2 in. long
 - 2 Self-threading nuts
2. Lay guide bars on table.

NOTE: The various holes in the bars allow them to be repositioned on the saw and also makes them adaptable to other models.
3. Insert 1-3/4 in. long screw through the FIRST hole from the LEFT IN THE FRONT BAR ... insert another 1-3/4 in. long screw through LARGE hole at

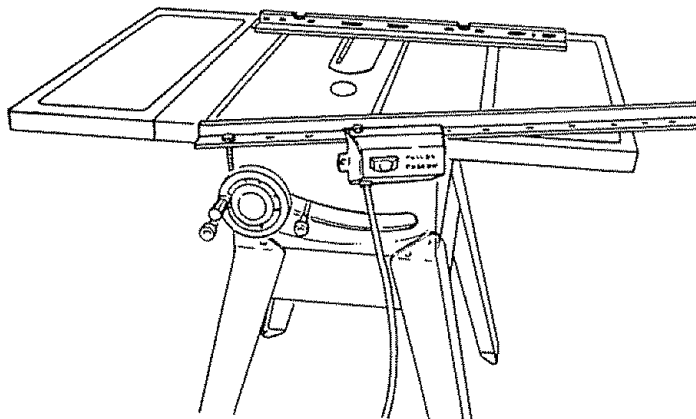

EXTREME LEFT SIDE OF SWITCH BRACKET then through SIXTH hole in bar. Hold them in place with a piece of masking tape from the underside.

4. Place spacers on screws.

5. Insert bolts through holes in middle and on right side of front of saw table ... install lockwashers and nuts. **DON'T SCREW NUTS ON ALL THE WAY**, just get them started on the screws.

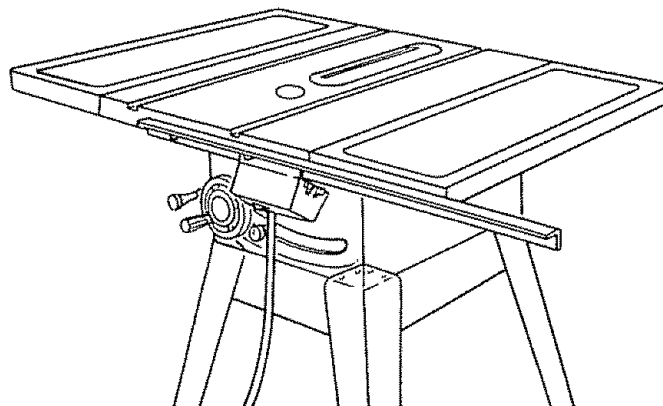

6. Remove the 3 screws from rear of table extension.
7. Insert 1 in. long screws in FIRST and THIRD holes of rear bar and attach to table the same way.
8. Insert ends of FENCE GUIDE BAR ROD through round holes at outer end of bars.

NOTE: The ends of the ROD are not threaded ... the SELF THREADING NUTS will cut threads on the rod as they are screwed on.

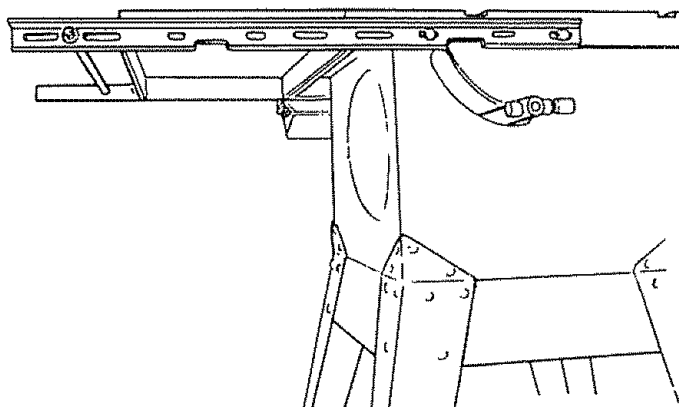

9. Hold rod with one hand and with a 1/2 in. wrench or pliers start screwing on ONE of the nuts only A TURN OR TWO . . . screw on other nut the same way.
10. Using TWO 1/2 in. wrenches or pliers tighten both of the nuts.

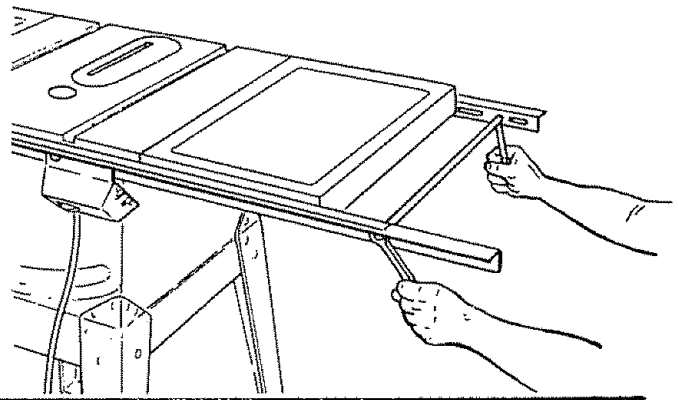

IMPORTANT: Apply a coat of paste wax to the top surface and front edge of the front guide bar. This will allow the fence to slide more easily.

11. Slide the bars so that screws are in the MIDDLE of the slotted holes.
12. Position rip fence over miter gauge groove, holding up the rear end while engaging front end with bar . . . lower fence onto table.

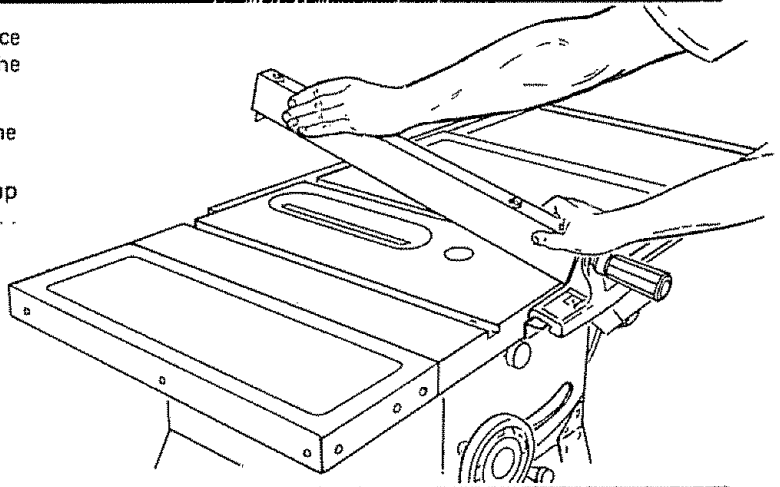
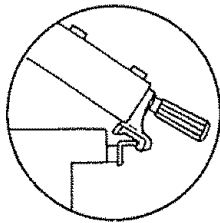

13. Raise blade all the way up.
14. Carefully move fence against blade.
15. Move front bar until "0" mark on rip scale is approximately in line with indicator.
16. Move FRONT bar upwards until fence is approximately 1/32 in. above table . . . tighten screw at left end of bar.
NOTE: Fold a piece of newspaper making 8 thicknesses and place between rip fence and table to act as a spacer. This will hold the fence off of the table approx. 1/32 in.
17. Adjust rear bar so that the fence is approximately 1/32 in. above table make sure it is square with fence guide bar rod . . . tighten screw at end of bar.
18. Replace screws in rear of table extension . . . be sure top surface of extension is PARALLEL to top surface of rear guide bar.

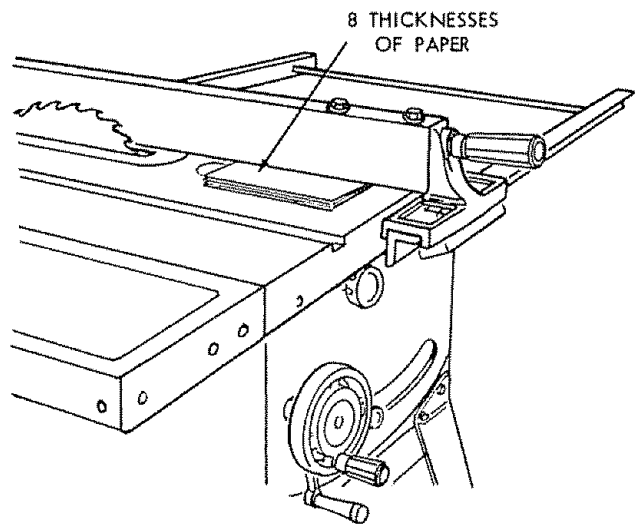

19. Move fence to RIGHT edge of table . . . make sure it is approx. 1/32 in. above table at front and rear and tighten screws.

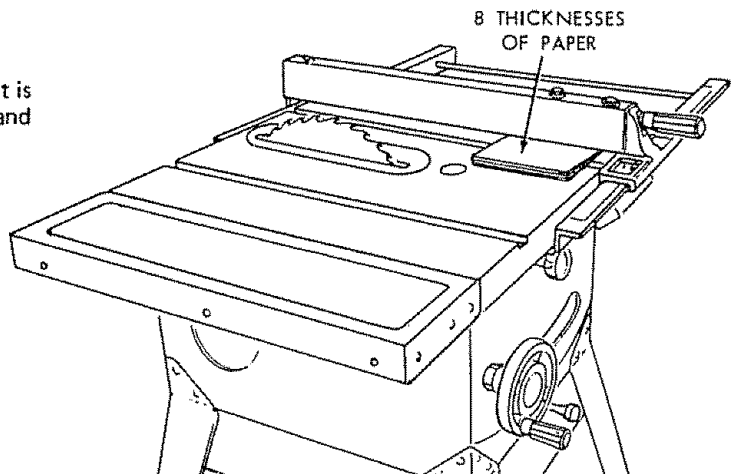

ALIGNING RIP FENCE

The fence should slide easily along the bars and always remain in alignment (parallel to sawblade and miter gauge grooves).

The alignment is maintained by a spring underneath the fence which bears against the front guide bar.

To move the fence, loosen the lock handle and grasp the fence with one hand at the front.

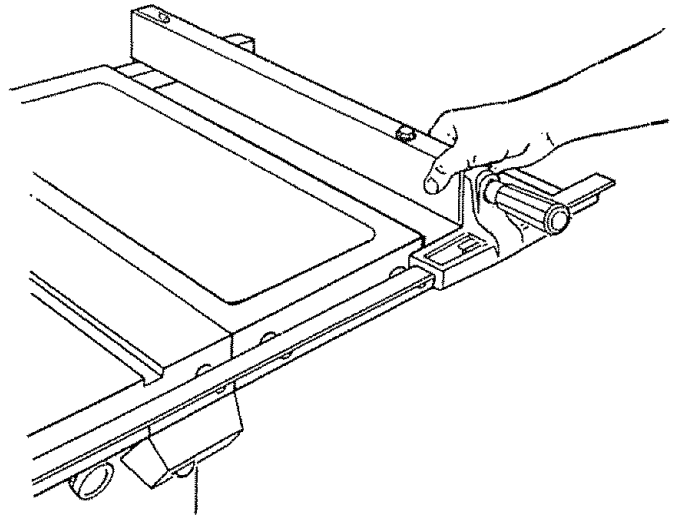

For very close adjustments, grasp the guide bar with both hands and move the fence with your thumbs.

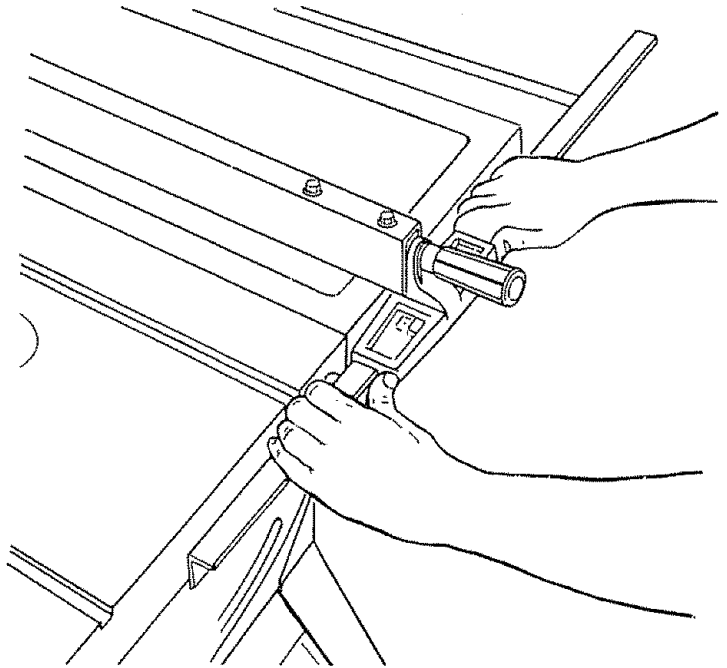

Place fence on saw but **DO NOT LOCK IT.**

Move the **REAR END** of the fence slightly to the right or left . . . when you release it, the fence should "spring" back to its original position.

If it does not, the spring pressure must be **INCREASED.**

1. Loosen the screws.
2. Move Spring slightly toward front of fence.

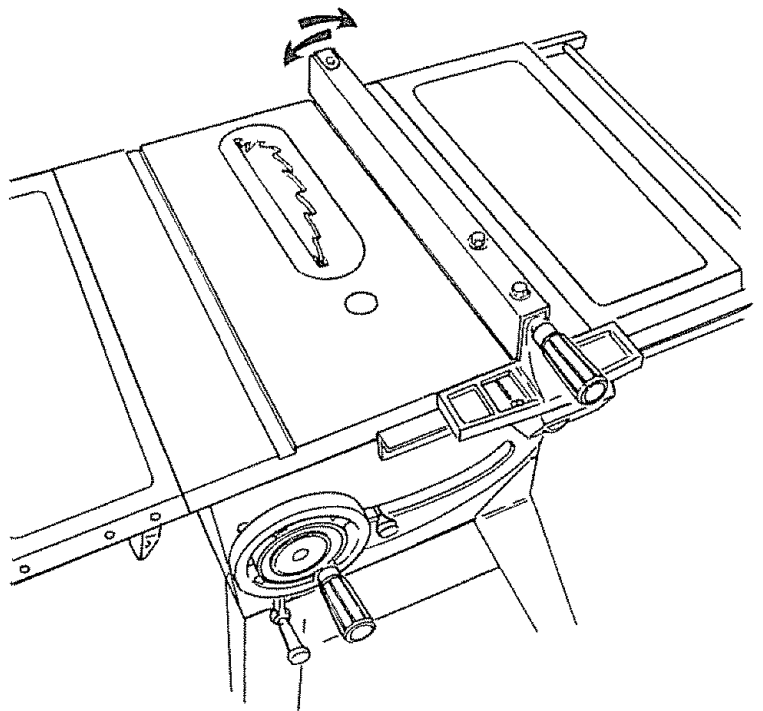

If the fence does not slide easily along the bars, the pressure of the spring can be REDUCED.

1. Loosen the screws.
2. Move spring slightly toward rear of fence ... tighten screws.

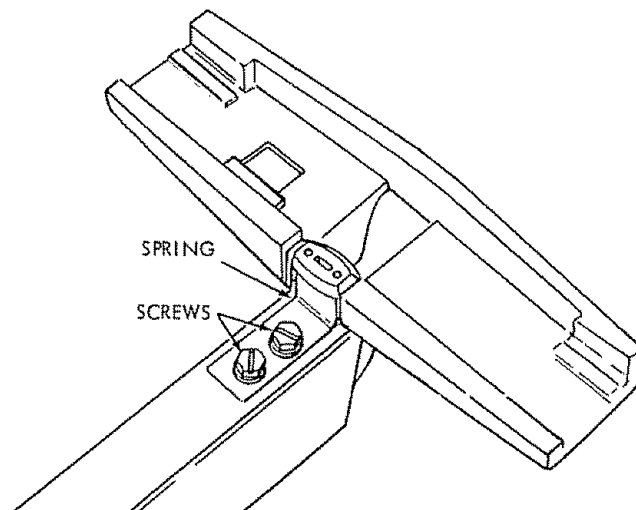

3. The rip fence must be PARALLEL with the sawblade (see page 23) and Miter Gauge grooves ... Move fence until it is along side of groove. Do NOT LOCK IT. It should be parallel to groove. If it is not;
 - A. Loosen the two "Hex. Head Screws."
 - B. Hold fence head tightly against bar ... move end of fence so that it is parallel with groove.
 - C. Alternately tighten the screws.

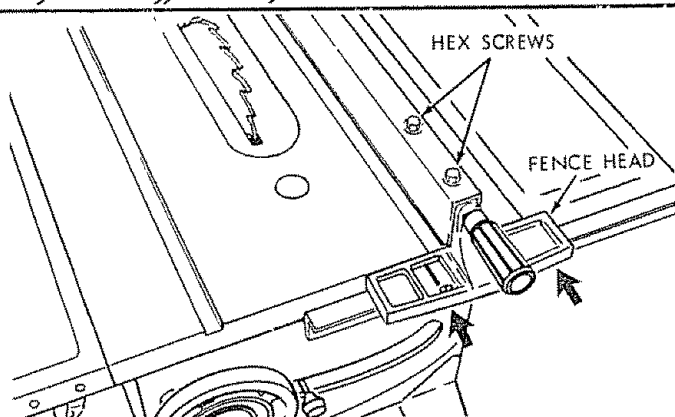

ADJUSTING RIP SCALE INDICATOR

1. Turn ELEVATION handwheel clockwise until blade is up as high as it will go.
IMPORTANT: BLADE must be SQUARE (90°) to TABLE, in order to ALIGN rip fence.
2. Position fence on right side of sawblade so that it touches the sides of the teeth ... tighten lock knob.
3. Loosen screw holding the indicator ... adjust indicator so that it points to "0" ... tighten screw.
NOTE: If you cannot adjust indicator so that it points to "0", loosen the screws holding the front guide bar and move the guide bar.

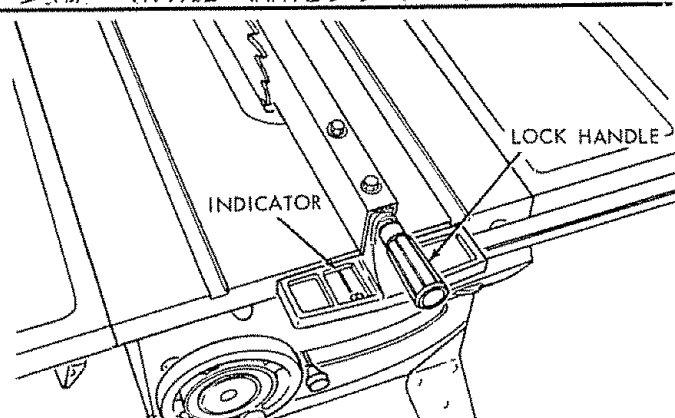

INSTALLING BLADE GUARD

1. From among the loose parts, find the hardware.
2. Attach SPREADER to SPREADER SUPPORT so that screws are all the way back in the SLOTS of SUPPORT ... hand tighten screws.

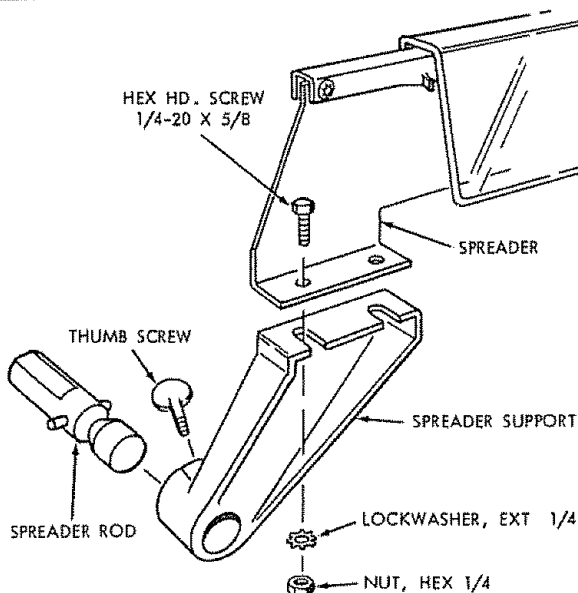

3. Slide support onto SUPPORT ROD until PIN in rod fits into notch in support ... insert THUMB SCREW and tighten it.
4. Loosen setscrew in end of SPREADER BAR using 5/32 in. setscrew wrench.
5. Lay blade of square or other straightedge along side blade. Move spreader so that it touches blade of square. Snug up setscrew (Do not tighten).
6. Make sure blade is square to table and raised as high as it will go

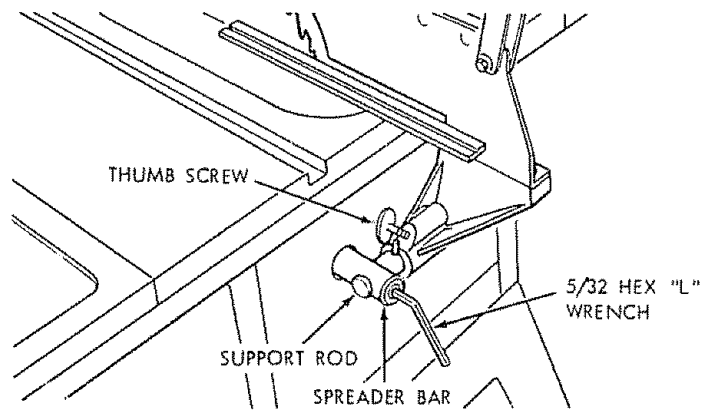

IMPORTANT: The SPREADER must always be PARALLEL to the sawblade and in the MIDDLE of the cut (KERF) made by the sawblade.

NOTE: The spreader is thinner than the width of the KERF by approximately sixteen thicknesses of paper.

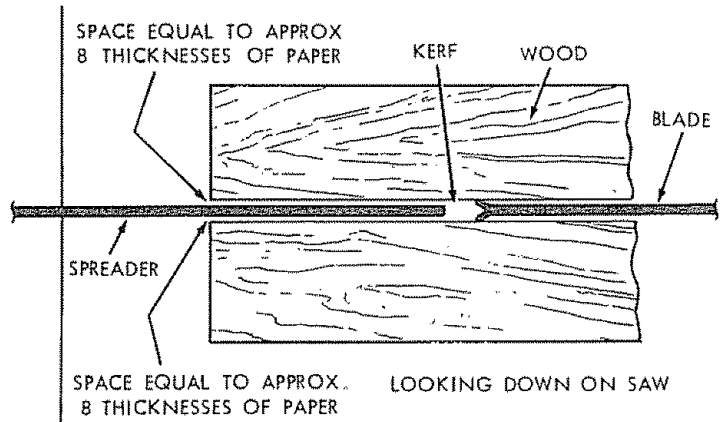

7. Make seven folds in a small piece (10 x 10 in.) of ordinary NEWSPAPER making eight thicknesses. The folded paper will be used as a "spacing gauge".

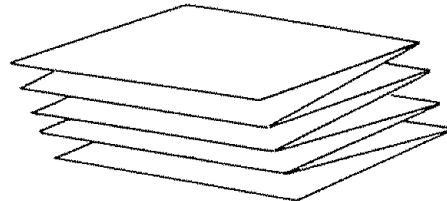

8. Place RIP FENCE on table ... CAREFULLY move it against blade so that it is parallel to the blade, and just TOUCHES tips of saw teeth ... tighten RIP FENCE LOCK KNOB.
9. Lift up both ANTICKICKBACK PAWLS ... insert one of the SETSCREW WRENCHES in the notches to hold the pawls out of the way.
10. Insert folded paper between SPREADER and FENCE ... hold spreader flat against fence ... tighten screws.
11. Now tighten setscrew in end of SPREADER BAR.
12. To remove blade guard, loosen thumb screw and slide guard off of SUPPORT ROD.

NOTE: Move fence away from spreader ... to see if spreader remains SQUARE with table.

If it is not square with table, the SPREADER BAR must be adjusted.

- A. Loosen 2 clamping screws, using a 1/2 in. wrench.
- B. Rotate bar until spreader is square with table.
- C. Check alignment of spreader with blade and readjust, if necessary.

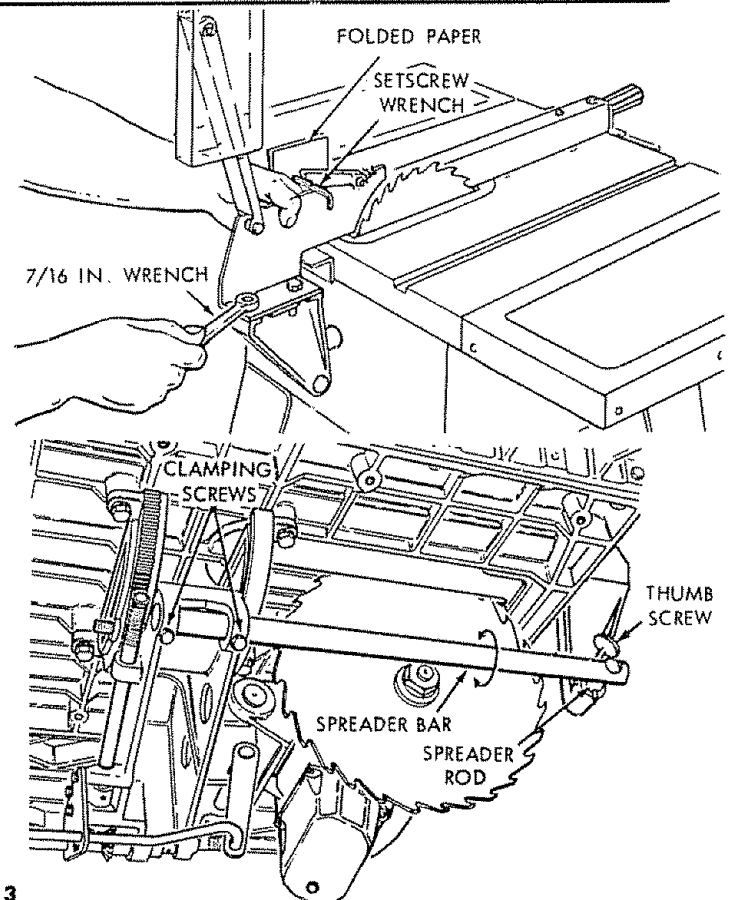

GETTING TO KNOW YOUR SAW

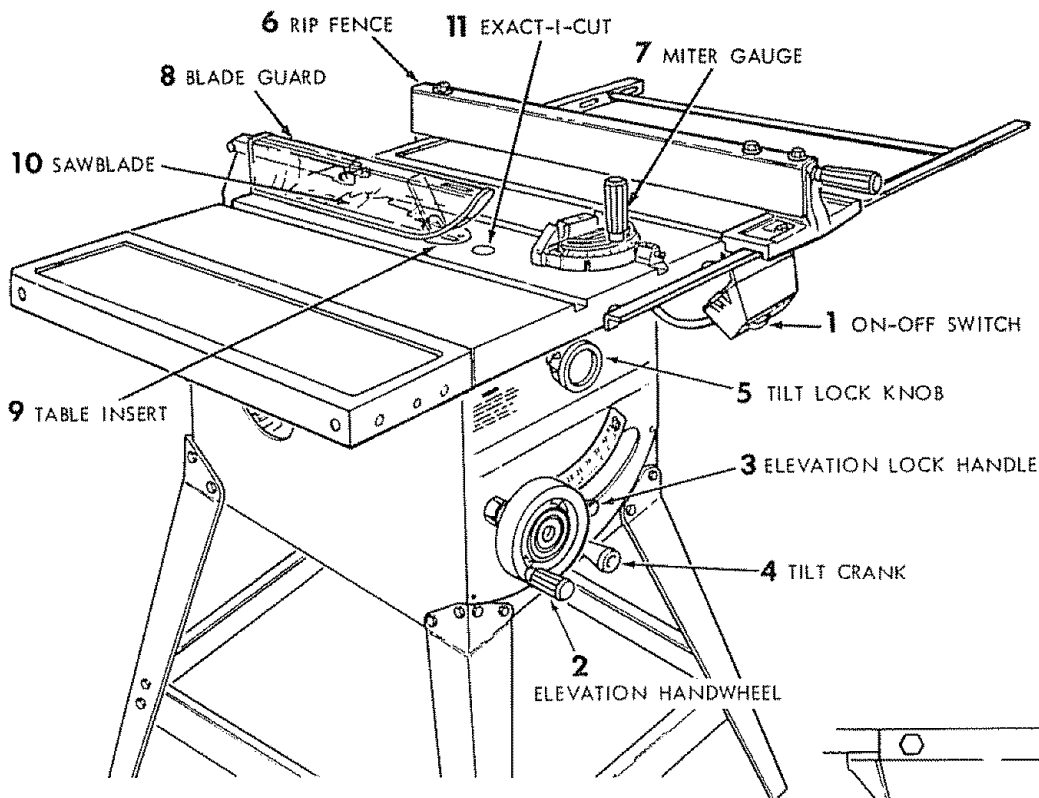

1 ON-OFF SWITCH

CAUTION: Before turning switch on, make sure the blade guard is correctly installed and operating properly.

The On-Off Switch has a locking feature. THIS FEATURE IS INTENDED TO PREVENT UNAUTHORIZED AND POSSIBLE HAZARDOUS USE BY CHILDREN AND OTHERS.

- B. TO turn saw ON ... stand to either side of the blade never in line with it ... insert finger under switch lever and pull END of lever out
After turning switch ON, always allow the blade to come up to full speed before cutting.
Do not cycle the motor switch on and off rapidly, as this may cause the sawblade to loosen. In the event this should ever occur, allow the sawblade to come to a complete stop and retighten the arbor nut normally, not excessively. Never leave the saw while the power is "ON".
- C. TO turn saw OFF ... PUSH lever in. Never leave the saw until the cutting tool has come to a complete stop.
- D. TO lock switch in OFF position ... hold switch IN with one hand ... REMOVE key with other hand

WARNING: FOR YOUR OWN SAFETY, LOWER BLADE OR OTHER CUTTING TOOL BELOW TABLE SURFACE. (IF BLADE IS TILTED, RETURN IT TO VERTICAL (90°) POSITION). ALWAYS LOCK THE SWITCH "OFF". WHEN SAW IS NOT IN USE ... REMOVE KEY AND KEEP IT IN A SAFE PLACE ... ALSO ... IN THE EVENT OF A POWER FAILURE (ALL OF YOUR LIGHTS GO OUT) TURN SWITCH OFF ... LOCK IT AND REMOVE THE KEY. THIS WILL PREVENT THE SAW FROM STARTING UP AGAIN WHEN THE POWER COMES BACK ON.

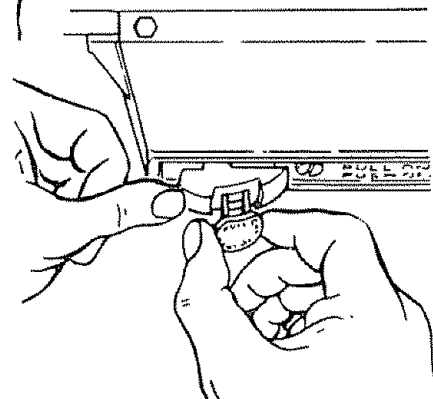
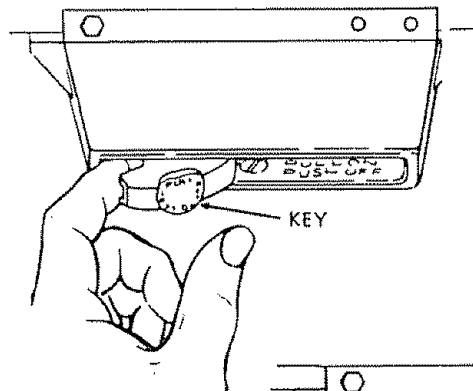
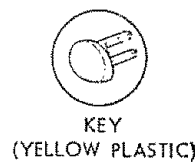

2 ELEVATION HANDWHEEL ... elevates or lowers the blade. Turn clockwise to elevate ... counterclockwise to lower.

3 ELEVATION LOCK ... locks the blade at the desired height. PUSH in to LOCK ... PULL out to unlock.

4 TILT CRANK ... tilts the blade for bevel cutting. Turn clockwise to tilt toward left ... counterclockwise to tilt toward right.

When the blade is tilted to the LEFT as far as it will go, it should be at 45° to the table and the bevel pointer should point 45°.

NOTE: There are LIMIT STOPS inside the saw which prevent the blade from tilting beyond 45° to the LEFT and 90° to the RIGHT. (See "Adjustments" section "Blade Tilt, or Squareness of Blade to Table")

5 TILT LOCK KNOB ... locks the blade in the desired tilt position. Turn it to the left to unlock ... to the right to lock.

6 RIP FENCE ... is locked in place by tightening the lock knob. To move the fence, loosen the knob and grasp the fence with one hand at the front.

Holes are provided in the rip fence for attaching a wood facing when using the dado head, or molding head.

Select a piece of smooth straight wood approx. 3/4 in. thick and the same size as the rip fence.

Attach it to the fence with three Round Head #10 Wood Screws 2 in. long. To remove the facing, loosen the screws, slide the facing forward and pull the screws through the round holes.

If you are making a rip type cut in material thinner than 3/16 in. while the fence is positioned over the depressed area of table extension, the facing should be attached to the fence so that the bottom edge touches the top surface of the extension. In this case, the facing must be shorter than the fence. This will prevent thin material from sliding under the rip fence

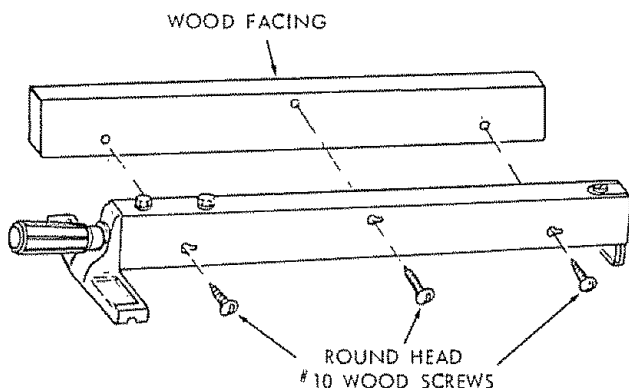

7 MITER GAUGE ... head is locked in position for crosscutting or mitering by tightening the lock knob ALWAYS LOCK IT SECURELY WHEN IN USE.

There are two slots for the stop pin at the 45 degree right and left positions for conveniently setting the Miter Gauge to cut miters.

NOTE: The slots for the stop pin and the graduations are manufactured to very close tolerances which provide accuracy for average woodworking. In some cases where extreme accuracy is required, when making angle cuts, for example, make a trial cut and then recheck it.

If necessary, the miter gauge head can then be swiveled slightly to compensate and then locked.

Slots are provided in the miter gauge for attaching an AUXILIARY FACING to make it easier to cut long pieces. Be positive facing does not interfere with the proper operation of the sawblade guard.

Select a suitable piece of smooth straight wood ... drill two holes through it and attach it with screws.

NOTE: When bevel crosscutting, attach facing so that it extends to the right of the miter gauge and use the miter gauge in the groove to the right of the blade.

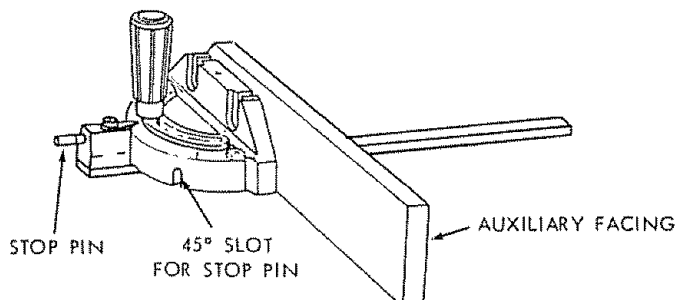

8 BLADEGUARD must always be in place and working properly for all thru-sawing cuts. That is, all cuts where by the blade cuts completely through the workpiece.

To remove the guard for special operations, loosen the thumbscrew and slide the guard off of the rod. DO NOT DISTURB THE SETTING OF THE ROD.

When replacing the guard, make sure the PIN in the rod engages with the NOTCH in the spreader support. Make sure thumbscrew is tightened securely.

9 TABLE INSERT is removable for removing or installing blades or other cutting tools.

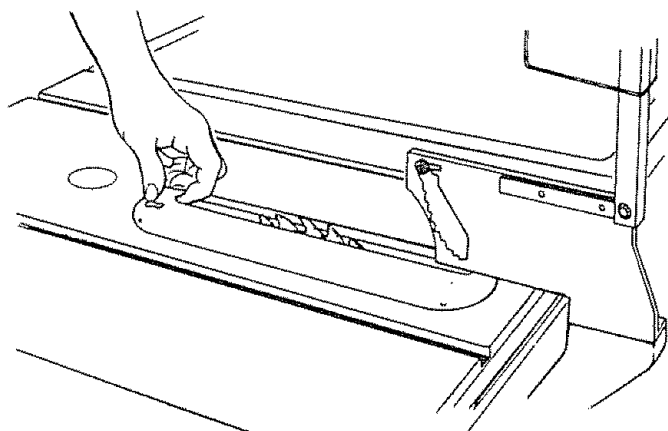

WARNING: FOR YOUR OWN SAFETY, TURN SWITCH "OFF" AND REMOVE PLUG FROM POWER SOURCE OUTLET BEFORE REMOVING INSERT.

- Lower the blade below the table surface.
- Raise blade guard.
- Loosen screw.
- Lift insert from front end, and pull toward front of saw

NEVER OPERATE THE SAW WITHOUT THE PROPER INSERT IN PLACE. USE THE SAW BLADE INSERT WHEN SAWING ... USE THE COMBINATION DADO/MOLDING INSERT WHEN DADOING OR MOLDING.

10 REMOVING AND INSTALLING SAWBLADE

WARNING: FOR YOUR OWN SAFETY, TURN SWITCH "OFF" AND REMOVE PLUG FROM POWER SOURCE OUTLET BEFORE REMOVING OR INSTALLING SAWBLADE.

- Remove insert.
- Place ARBOR wrench on flat surfaces of saw ARBOR NUT wrench on nut ... position wrenches as shown ... hold your hands well above blade.
- With ARBOR wrench against table, PULL ARBOR NUT wrench FORWARD to LOOSEN nut.
- To TIGHTEN nut ... HOLD ARBOR wrench against rear of table ... PUSH ARBOR NUT wrench toward rear.

NOTE: When installing the blade ... make sure the teeth are pointing toward the front of the saw ... and that the blade and collars are clean, and free from any burrs.

The HOLLOW side of the collars must be against the blade.

Always tighten the arbor nut securely.

To replace insert.

Place insert into insert opening in table and push toward rear of saw to engage spring clip and until keyslot in insert will drop over screw. Tighten screw.

Do not tighten screw to the point where it will deflect the insert.

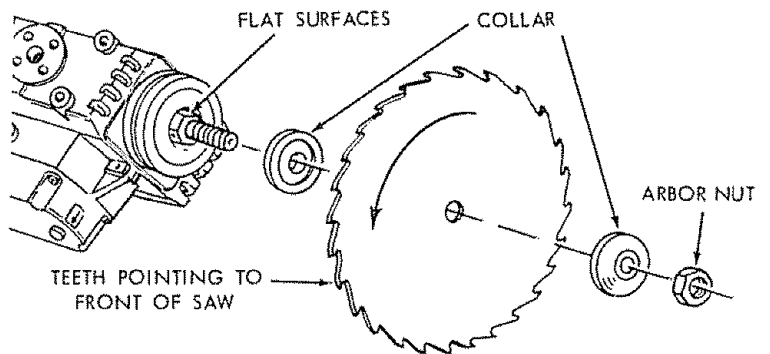
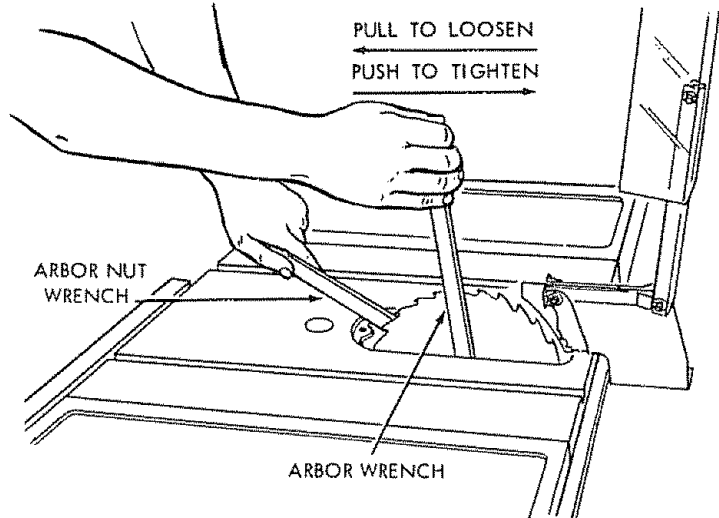

11 EXACT-I-CUT

The "yellow" plastic disc imbedded in the table in front of the sawblade, is provided for marking the location of the "sawcut" on the workpiece.

- Check disc ... if it is above table surface, place a piece of hardwood on top of it and tap it down.
- With blade 90° (square to table) cut off a piece of wood.
- Pull miter gauge back until wood is over disc. Using very sharp pencil, mark a line on disc.
- With miter gauge in right hand groove, follow same procedure and mark another line on disc.
- These lines indicate the "path" of the cut (kerf) made by the sawblade.
- When cutting the workpiece, line up mark on workpiece with line on disc.

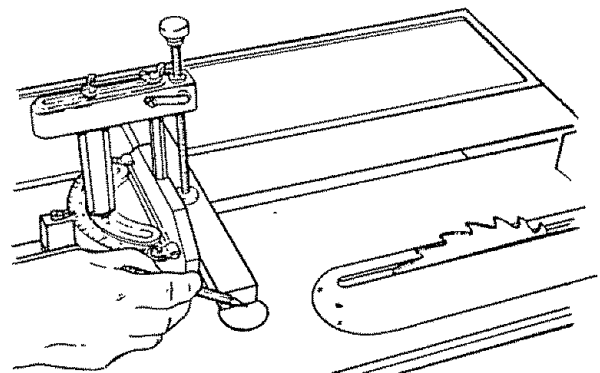

BLADE GUARD NOT SHOWN FOR PICTURE CLARITY

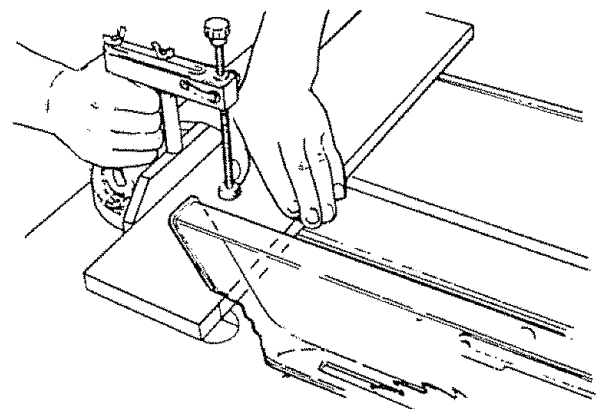

CROSSCUTTING

CROSSCUTTING is known as cutting wood across the grain, at 90°, or square with both the edge and the flat side of the wood. This is done with miter gauge set at "0".

The graduations on the miter gauge provide accuracy for average woodworking. In some cases where extreme accuracy is required, when making angle cuts, for example, make a trial cut and then recheck it with an accurate square, or protractor.

If necessary, the miter gauge head can be swiveled slightly to compensate for any inaccuracy.

NOTE: The space between the miter gauge bar and the groove in the table is held to a minimum during manufacturing.

For maximum accuracy when using the miter gauge, always "favor" one side of the groove in the table. In other words, don't move the miter gauge from side to side while cutting, but keep one side of the bar riding against one side of the groove.

NOTE: Glue a piece of sandpaper to the face of the miter gauge head. This will help prevent the workpiece from "creeping" while it is being cut.

The Hold-Down Clamp (Optional Accessory) should be used on the miter gauge for greater accuracy.

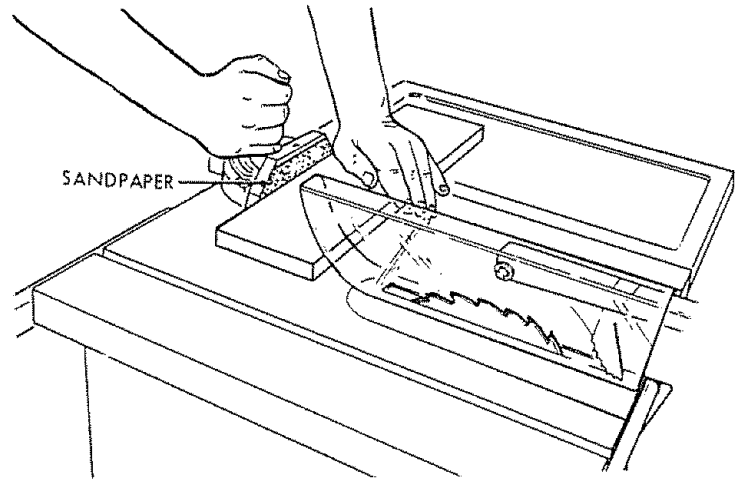

The miter gauge may be used in either of the grooves in the table. Make sure it is locked.

When using the miter gauge in the LEFT hand groove, hold the workpiece firmly against the miter gauge head with your left hand, and grip the lock knob with your right.

When using the RIGHT Hand groove, hold the workpiece with your right hand and the lock knob with your left hand.

When cutting long workpieces, invert AUXILIARY FENCE/WORK SUPPORT and position it on top of the guide bars to support the workpiece as near to the end as possible. If this does not adequately support the workpiece, you can make a simple support by clamping a piece of plywood to a sawhorse.

Use the Hold-Down Clamp (Optional Accessory) on the miter gauge for greater accuracy.

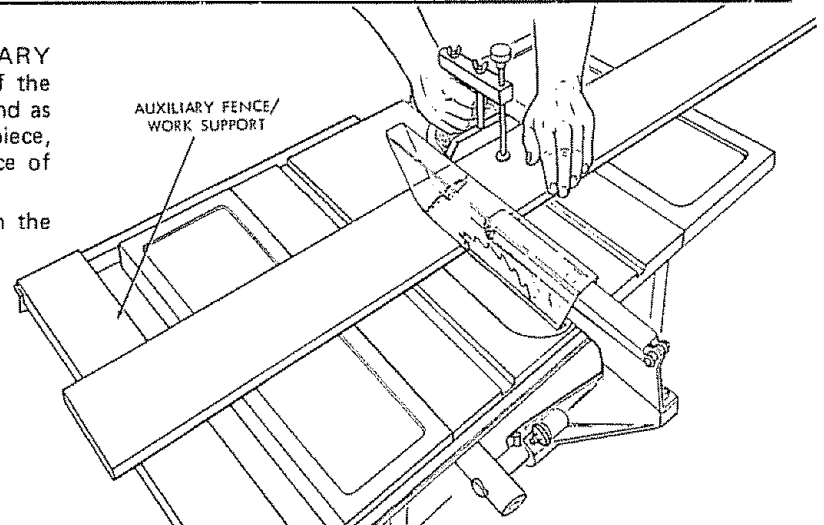

REPETITIVE CUTTING

REPETITIVE CUTTING is known as cutting a quantity of pieces the same length without having to mark each piece.

1. Use the Stop Rods (optional accessory) only for cutting duplicate pieces 6 in. long and longer.
2. DO NOT FEED workpiece with RIGHT Hand. merely guide it, making sure that it does not bind or pinch the sawblade.

When making repetitive cuts from a long workpiece, make sure it is adequately supported.

Use the Hold-Down Clamp (Optional Accessory) on the miter gauge for greater accuracy.

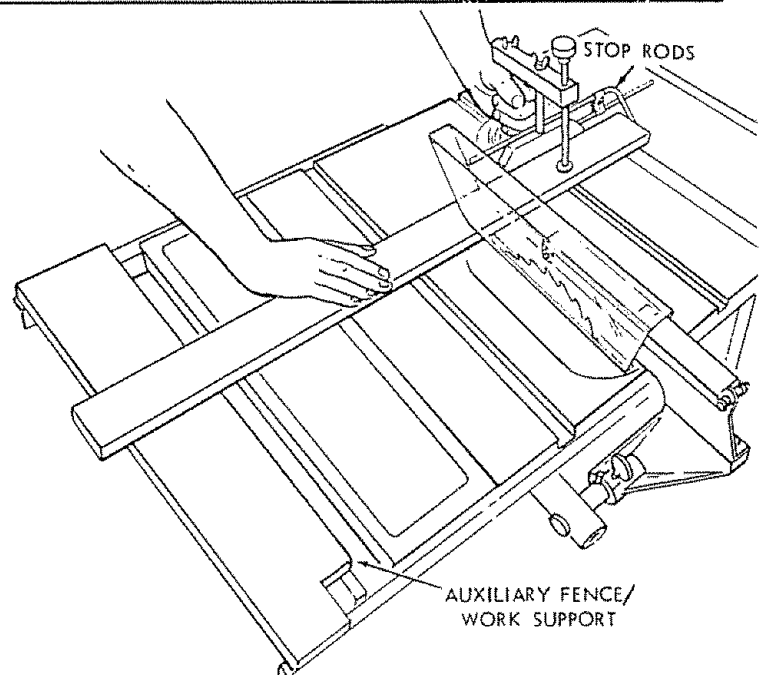

1. NEVER USE THE RIP FENCE AS A LENGTH STOP BECAUSE THE CUTOFF PIECE COULD BIND BETWEEN THE FENCE AND THE BLADE CAUSING A KICKBACK.
2. When making repetitive cuts shorter than 6 in., clamp a block of wood 2 in. long to the table to act as a length stop. Do not clamp directly to the bottom edge of the table because the "swivel" of the clamp will not grip properly. Place a small block of wood between the bottom edge of the table and the "C" clamp.
CAUTION: When clamping the block, make sure that the end of the block is well in front of the sawblade. Be sure it is clamped securely.
3. Slide the workpiece along the miter gauge until it touches the block . . . hold it securely or clamp it with the Hold-Down Clamp (Optional Accessory).
4. Make the cut . . . pull the workpiece back . . . push the cut off piece off the table with a long push stick . . . DO NOT ATTEMPT TO PICK IT UP AS THIS COULD ENDANGER YOUR HANDS.

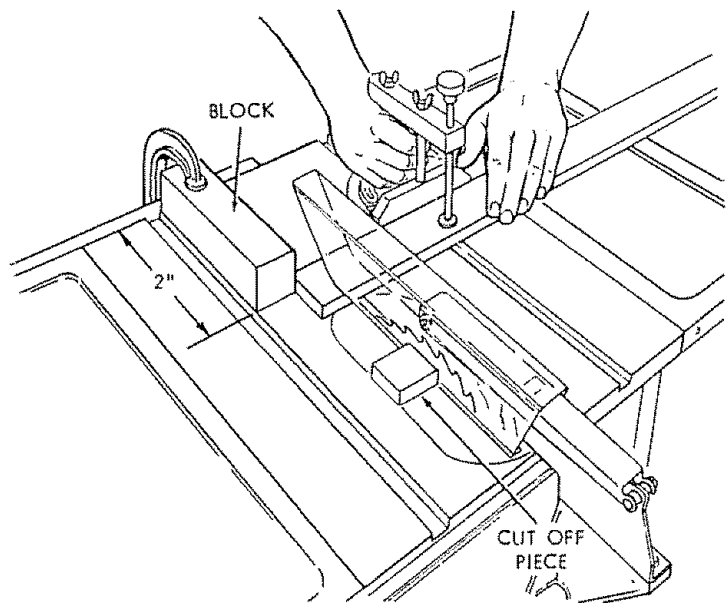

MITER CUTTING

MITER CUTTING is known as cutting wood at an angle other than 90° with the edge of the wood. Follow the same procedure as you would for crosscutting.

Adjust the miter gauge to the desired angle, and lock it.

The miter gauge may be used in either of the grooves in the table.

When using the miter gauge in the LEFT Hand groove, hold the workpiece firmly against the miter gauge head with your left hand, and grip the lock knob with your right.

When using the RIGHT hand groove, hold the workpiece with your right hand and the lockknob with your left hand.

Use the Hold-Down Clamp (Optional Accessory) on the miter gauge for greater accuracy.

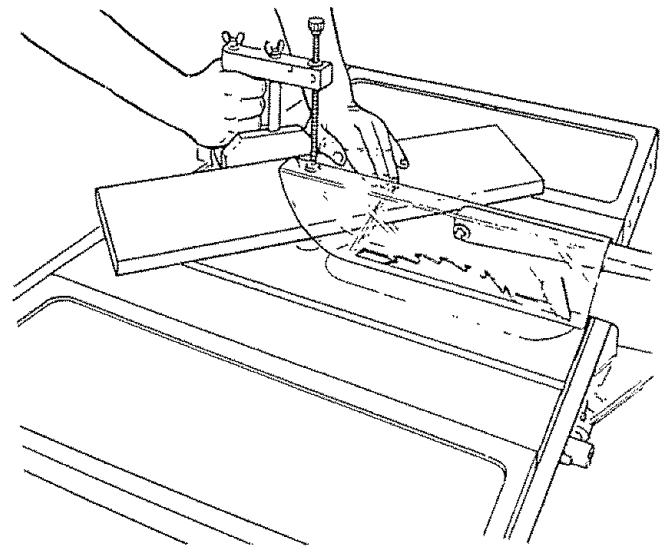

BEVEL CROSSCUTTING

BEVEL CROSSCUTTING is the same as crosscutting except that the wood is also cut at an angle . . . other than 90° with the flat side of the wood.

Adjust the blade to the desired angle.

Use the Miter Gauge in the groove to the RIGHT of the blade. It cannot be used in the groove to the LEFT because the blade guard will interfere. Hold the workpiece with your right hand and the lockknob with your left hand.

Use the AUXILIARY FENCE/WORK SUPPORT for additional support of the workpiece.

Lay it across the guide bars to support the workpiece as near to the end as possible.

Use the Hold-Down Clamp (Optional Accessory) on the miter gauge for greater accuracy.

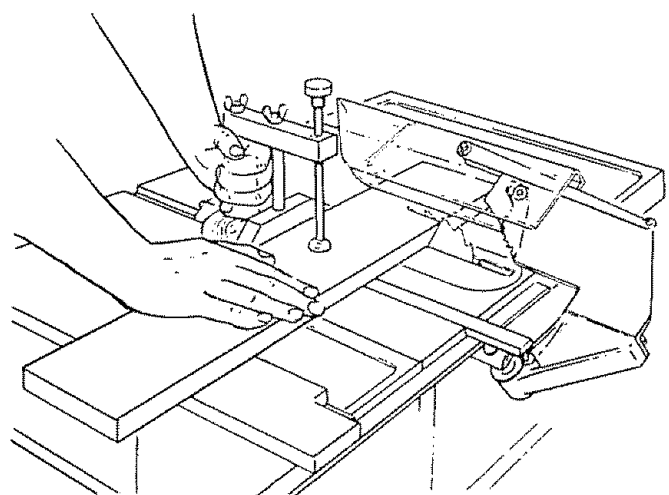

COMPOUND MITER CUTTING

COMPOUND MITER CUTTING is a combination of miter cutting and bevel crosscutting. The cut is made at an angle other than 90° to both the edge and the flat side of the wood.

Adjust the miter gauge and the blade to the desired angle . . . Make sure miter gauge is locked.

USING THE RIP FENCE

RIPPING, BEVEL RIPPING, RESAWING AND RABBETING are performed using the RIP FENCE together with the AUXILIARY FENCE/WORK SUPPORT, PUSH STICK OR PUSH BLOCK.

WARNING: FOR YOUR OWN SAFETY, ALWAYS OBSERVE THE FOLLOWING SAFETY PRECAUTIONS IN ADDITION TO THE SAFETY INSTRUCTIONS ON PAGES 2, 3, and 4.

1. Never make these cuts FREEHAND (without using the rip fence or auxiliary devices when required) because the blade could bind in the cut and cause a KICKBACK.
2. Always lock the rip fence securely when in use.
3. Remove miter gauge from table.
4. Make sure blade guard is installed for all thru-sawing type cuts. Replace the guard IMMEDIATELY following completion of resawing, rabbeting, dadoing, or molding operations.
Frequently check the action of the ANTIKICKBACK PAWLS by passing the workpiece alongside of the spreader while saw is OFF.
Pull the workpiece TOWARD you. If the PAWLS do

not DIG into the workpiece and HOLD it . . . the pawls must be SHARPENED. See "Maintenance" section.

5. Have blade extend approximately 1/8 in. above top of workpiece. Additional blade exposure would increase the hazard potential.
6. Do not stand directly in front of the blade in case of a KICKBACK. Stand to either side of the blade.
7. Keep your hands clear of the blade and out of the path of the blade.
8. If the blade stalls or stops while cutting. TURN SWITCH OFF before attempting to free the blade.
9. Do not reach over or behind the blade to pull the workpiece through the cut . . . to support long or heavy workpieces . . . to remove small cut-off pieces of material or FOR ANY OTHER REASON.
10. Do not pick up small pieces of cut-off material from the table. REMOVE them by pushing them OFF the table with a long stick. Otherwise they could be thrown back at you by the rear of the blade.
11. Do not remove small pieces of cut-off material that may become TRAPPED inside the blade guard while the saw is RUNNING. THIS COULD ENDANGER YOUR HANDS or cause a KICKBACK.
Turn the saw OFF. After the blade has stopped turning, lift the guard and remove the piece.

RIPPING

RIPPING is known as cutting a piece of wood with the grain, or lengthwise. This is done using the rip fence. Position the fence to the desired WIDTH OF RIP and lock in place.

Before starting to rip, be sure

- A. Rip Fence is parallel to sawblade.
- B. Spreader is properly aligned with sawblade.
- C. Antikickback pawls are functioning properly.

When ripping LONG BOARDS or LARGE PANELS, always use a work support.

A simple one can be made by clamping a piece of plywood to a sawhorse.

BEVEL RIPPING

When bevel ripping material 6 in. or narrower, use fence on the right side of the blade ONLY. This will provide more space between the fence and the sawblade for use of a push stick. If the fence is mounted to the left, the sawblade guard may interfere with proper use of a push stick.

ALWAYS SUPPORT LONG WORKPIECES

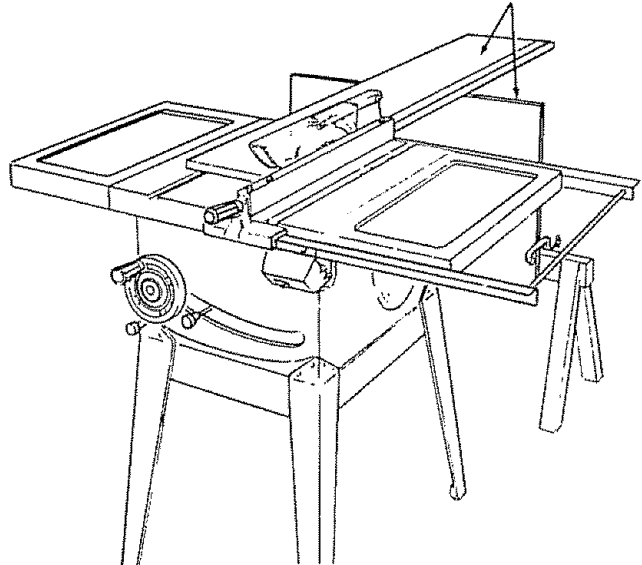

When "WIDTH OF RIP" is 6 in. and WIDER use your RIGHT Hand to feed the workpiece until it is clear of the table.

Use LEFT hand ONLY to guide the workpiece . . . do not FEED the workpiece with the left hand.

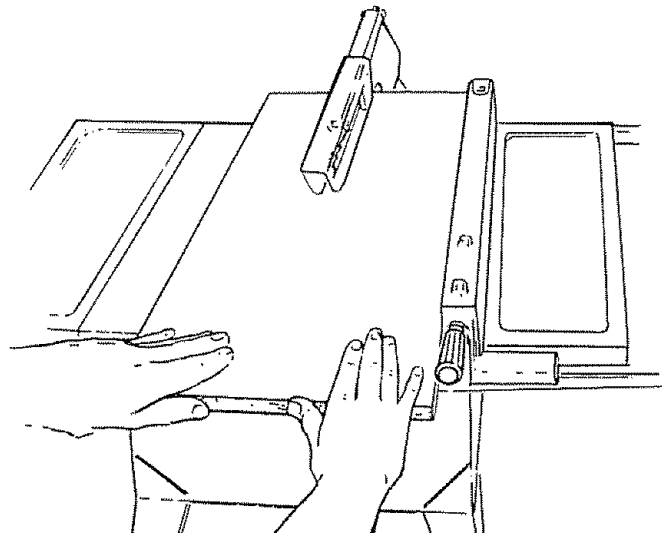

When "WIDTH OF RIP" is 2 in. to 6 in. wide USE THE PUSH STICK to feed the work.

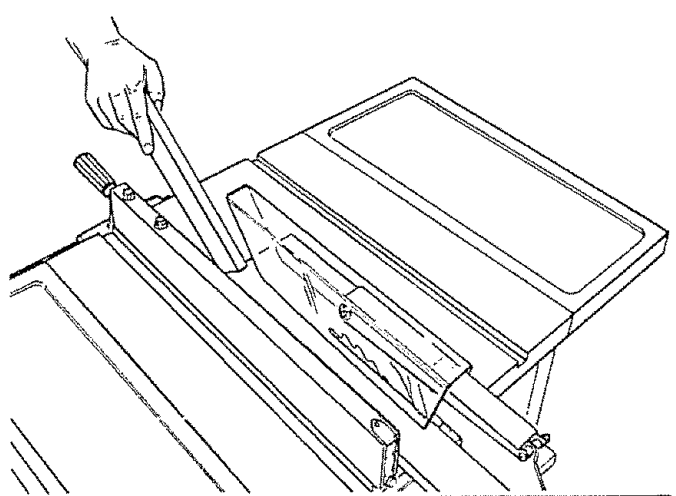

When WIDTH OF RIP is NARROWER than 2 in., the push stick CANNOT be used because the guard will interfere . . . USE the AUXILIARY FENCE/WORK SUPPORT and PUSH BLOCK.

Attach Auxiliary Fence/Work Support to rip fence with two "C" clamps.

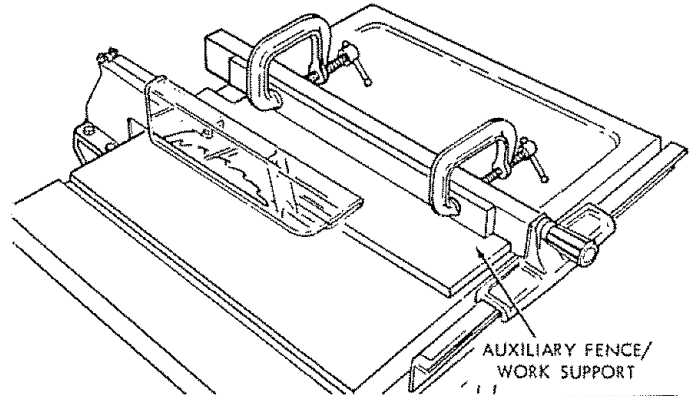

Feed the workpiece by hand along the AUXILIARY FENCE/WORK SUPPORT until the end is approx. 1 in. past the front edge of the table. Continue to feed using the PUSH BLOCK.

Hold the workpiece in position and install the PUSH BLOCK by sliding it on top of the AUXILIARY FENCE/WORK SUPPORT (This May Raise Guard)

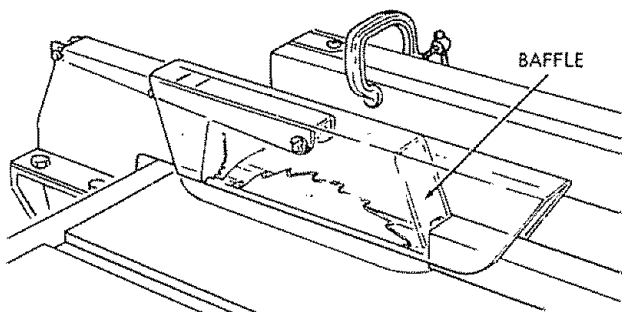
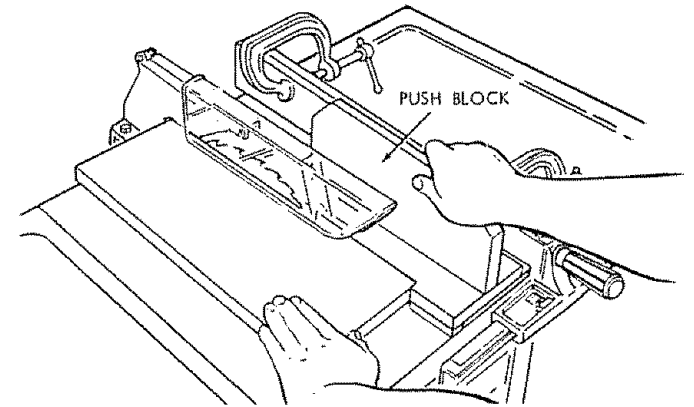

Narrow strips thicker than the Auxiliary Fence/Work Support may enter the guard and strike the baffle.

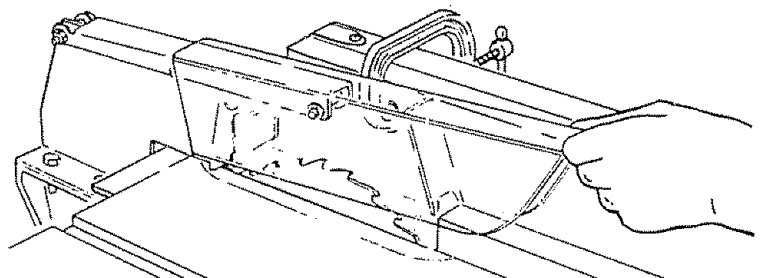

CAREFULLY raise guard only enough to clear the workpiece. Use PUSH BLOCK to complete cut.

PLOUGHING AND MOLDING

PLOUGHING is grooving with the grain the long way of the workpiece, using the fence. USE proper holddowns and feed devices.



MOLDING is shaping the workpiece with the grain the long way of the workpiece, using the fence. Use proper holddowns and feed devices.



RESAWING

RESAWING is known as ripping a piece of wood through its thickness. Do not attempt to resaw BOWED or WARPED material. NOTE: To RESAW a piece of wood wider than 3-9/16 in. . . . it will be necessary to remove the blade guard . . . and use the AUXILIARY FENCE/WORK SUPPORT. (See "Work Helpers").

Clamp it to the table so that the workpiece will SLIDE EASILY (but not TILT or MOVE SIDEWAYS) without BINDING between the two fences.

Do not clamp directly to the bottom edge of the table because the "swivel" of the clamp will not grip properly. Place a small block or wood between the bottom edge of the table and the "C" clamp.

WARNING: FOR YOUR OWN SAFETY . . .

1. DO NOT "BACK UP" (REVERSE FEEDING) WHILE RESAWING BECAUSE THIS COULD CAUSE A KICKBACK.

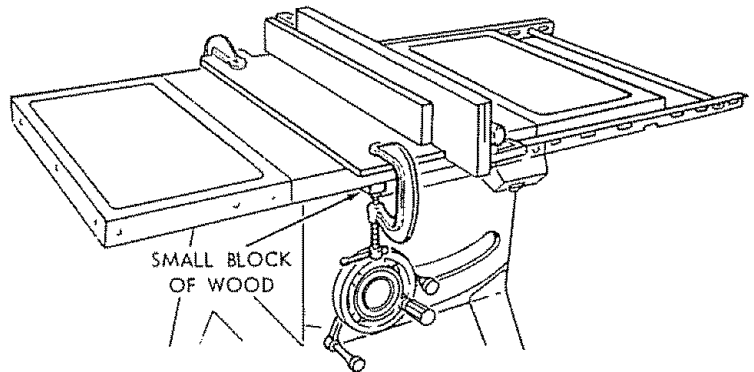

2. INSTALL BLADE GUARD IMMEDIATELY UPON COMPLETION OF THE RESAWING OPERATION.

CUTTING PANELS

When cutting panels (whenever fence is positioned outside of table surface), ALWAYS use the AUXILIARY FENCE/WORK SUPPORT.

1. Unlock fence and raise rear end.
2. Position AUXILIARY FENCE/WORK SUPPORT as shown and attach it with two "C" clamps.

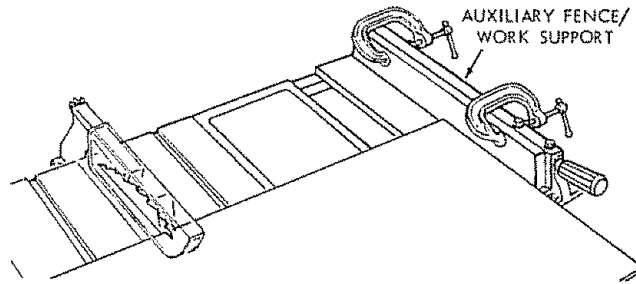

RABBETING

Rabbeting is known as cutting out a section of the corner of a piece of material, across an end or along an edge

To make a RABBIT requires two cuts which do not go all the way through the material. Therefore the blade guard must be removed.

1. Remove blade guard.
2. For rabbeting along an edge (long way of workpiece) add facing to rip fence (see 6. RIP FENCE, p. 15) approximately as high as the workpiece is wide. Adjust rip fence and blade to required dimensions, then make first cut with board flat on table as any rip (type) cut; make second cut with workpiece on edge. Follow all precautions, safety instructions, and operational instructions as for ripping, rip type operations, including feather boards and push sticks, etc.

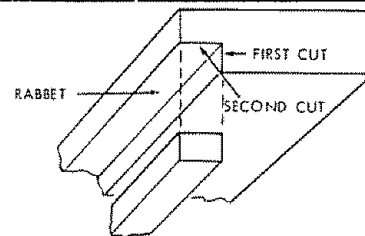

3. For rabbeting across an end for workpiece 10-1/2" and narrower make the rabbet cut with the board flat on the table using the miter gage fitted with a facing (per "7 Miter Gauge" on p. 15). DO NOT use the rip fence.
4. INSTALL BLADE GUARD IMMEDIATELY UPON COMPLETION OF RABBETING OPERATION.

Rabbet cuts can also be made using the dado head or molding head.

DADOING

Instructions for operating the Dado Head are contained in booklet furnished with the Dado Head.

The recommended Dado Head is listed under recommended accessories.

The arbor on the saw, is only long enough so that the widest cut that can be made is 13/16" wide.

It is not necessary to install the outside loose collar before screwing on the arbor nut. Make sure the arbor nut is tight.

ALWAYS USE DADO INSERT LISTED UNDER RECOMMENDED ACCESSORIES.

When using the dadoing head it will be necessary to remove the Blade Guard and Spreader. USE CAUTION. Use featherboards and pushsticks as required.

ALWAYS REPLACE THE BLADE GUARD AND SPREADER WHEN YOU ARE FINISHED DADOING.

MOLDING CUTTING

Instructions for operating the Molding Head are contained in a booklet furnished with the Molding Head.

The recommended molding head is listed under recommended accessories.

Always use Molding Insert Listed Under Recommended Accessories.

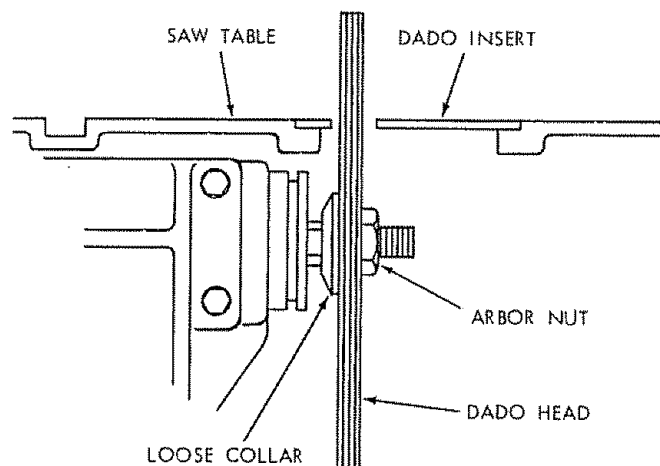

When using the molding head it will be necessary to remove the Blade Guard and Spreader. USE CAUTION. Use featherboards and push sticks etc. as required.

ALWAYS REPLACE THE BLADE GUARD AND SPREADER WHEN YOU ARE FINISHED MOLDING.

USING FEATHERBOARDS

Add 8 inch high flat facing board to the fence, the full length of the fence.

Use featherboards for all non "thru-sawing" operations (when sawblade guard must be removed). Featherboards are used to keep the work in contact with the fence and table as shown, and to stop kickbacks.

Mount featherboards to fence and table as shown, so that leading edges of featherboards will support workpiece until cut is complete, and the workpiece has been pushed completely past the cutter (sawblade, dado head, molding head, etc.) with a pushstick, as in ripping.

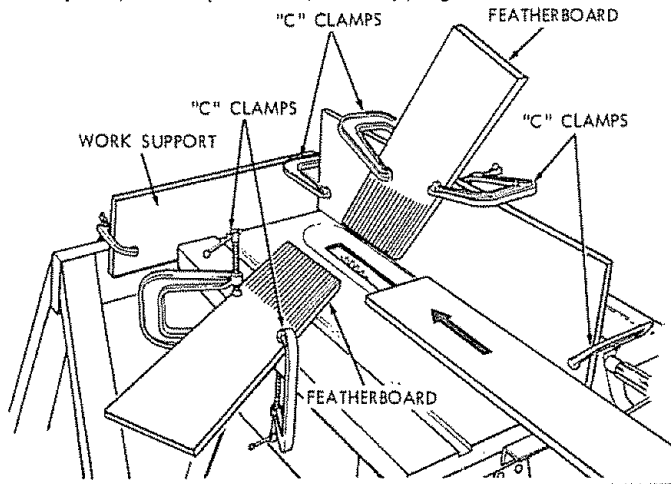

Before starting the operation (switch "OFF" and cutter below table surface):

- (a) Install featherboards so they exert pressure on the workpiece; be positive they are secure, and
- (b) Make sure by trial that the featherboards will stop a kickback if one should occur.

Featherboards are not employed during non thru-sawing operations when using the miter gage.

Replace the sawblade guard as soon as the non thru-sawing operation is complete.

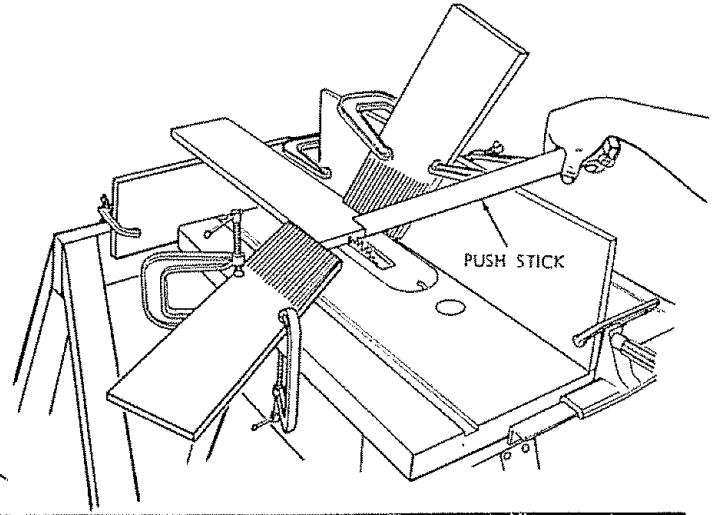

ADJUSTMENTS

(Not previously noted)

WARNING: FOR YOUR OWN SAFETY, TURN SWITCH "OFF" AND REMOVE PLUG FROM POWER SOURCE OUTLET BEFORE MAKING ANY ADJUSTMENTS.

MITER GAUGE

NOTE: The holes for the stop pin and the graduations are manufactured to very close tolerances which provide accuracy for average woodworking. In some cases where extreme accuracy is required, when making angle cuts, for example, make a trial cut and then recheck it.

If necessary, the miter gauge head can be swiveled slightly to compensate for any inaccuracy.

1. Loosen the "knob" and pull "stop pin" OUT.
2. Swivel the head ... position it at "0" ... push the stop pin IN ... lock the handle.
3. The HEAD should be square with the Bar and the pointer should point to "0". Readjust the pointer if necessary.
4. If the head is not square with the bar, adjustments are required.
 - A. Loosen the "knob" (1) and the "two screws" (2)
 - B. Position the HEAD square with the BAR using a combination square.
 - C. PUSH the STOP PIN into the slot in the head at "0" ... push the pin into the slot and twist it. Lock the knob.
 - D. Recheck with the square. If the head is still not square, loosen the screws (2) and readjust the INDICATOR BLOCK.
 - E. With the head square with the bar and the pin pushed into the slot, adjust the pointer (3) to point to "0".
 - F. The miter gauge head must rest on top of the bar without being able to move up and down ... yet it must swivel freely.

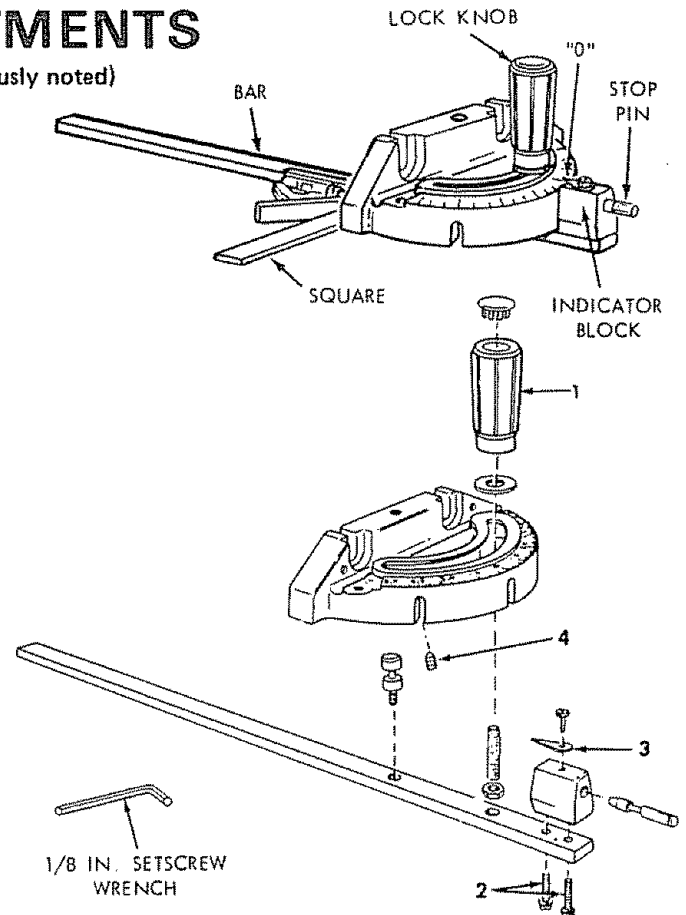

- G. The swiveling movement of the head can be adjusted by tightening or loosening the setscrew (4) ... using the 1/8 in. setscrew wrench.

NOTE: The setscrew is located inside of the head. To reach it, swivel the head to 60 degrees and turn the miter gauge upside down.

HEELING ADJUSTMENT or PARALLELISM OF SAWBLADE TO MITER GAUGE GROOVE

While cutting, the material must move in a straight line PARALLEL to the SAWBLADE ... therefore both the miter gauge GROOVE and the RIP FENCE must be PARALLEL to the SAWBLADE.

If the sawblade IS NOT parallel to the miter gauge groove, the blade will bind at one end of the cut. (This is known as "HEELING").

To check for parallelism:

WARNING – FOR YOUR OWN SAFETY, TURN SWITCH "OFF" AND REMOVE PLUG FROM POWER SOURCE OUTLET.

1. Raise blade all the way up ... raise blade guard.
2. Mark as "x" on one of the teeth which is SET (bent) to the LEFT.
3. Place the head of a combination square in the GROOVE ... adjust blade of square so that it just touches the tip of of the MARKED tooth.
4. Move square to REAR, rotate blade to see if MARKED tooth again touches blade of square.
5. If tooth touches square the same amount at FRONT and REAR ... sawblade is PARALLEL to MITER GAUGE GROOVE.

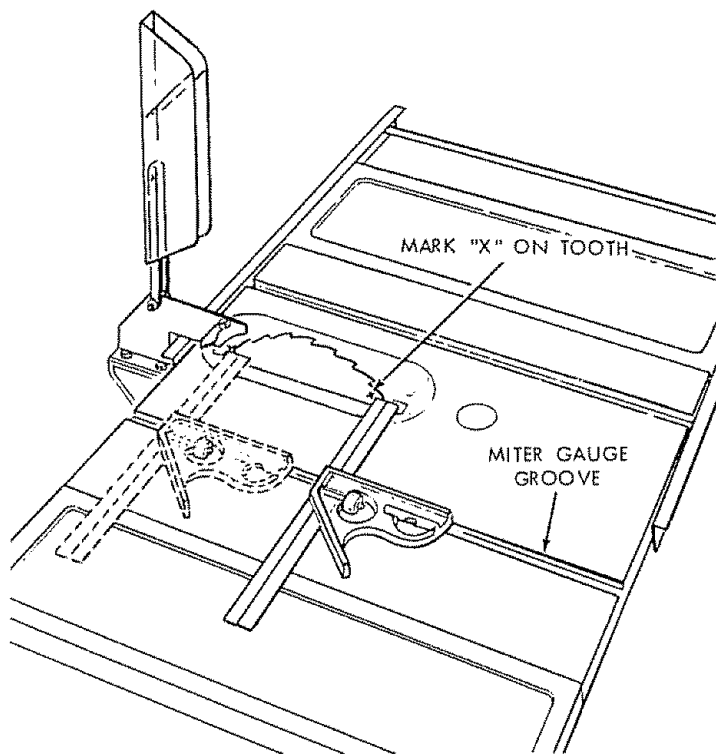

If tooth does not touch Front and Rear ... the mechanism underneath must be adjusted to make the blade PARALLEL to GROOVE.

NOTE: Make sure TILT CLAMP KNOB is tightened.

1. Lay the saw on its LEFT SIDE.
2. Loosen Hex. Head screw "A" between 1/4 and 1/2 turn, using a 5/8 in. socket wrench with an extension.
3. Tilt blade to 45° and loosen screw "B".
4. Place saw in upright position ... tilt blade to 90°.
5. Remove blade ... lower the motor all the way down.
6. Reach inside of the insert opening and loosen screws "C" and "D" 1/4 to 1/2 turn, using a 5/8 in. wrench.
7. Replace sawblade and raise it all the way up.
8. Grasp spreader bar at rear of saw and move sideways ... recheck blade alignment with square.
9. When blade is PARALLEL to groove ... tighten screws "C" and "D".
10. Lay saw on its LEFT SIDE and tighten screws "A" and "B".

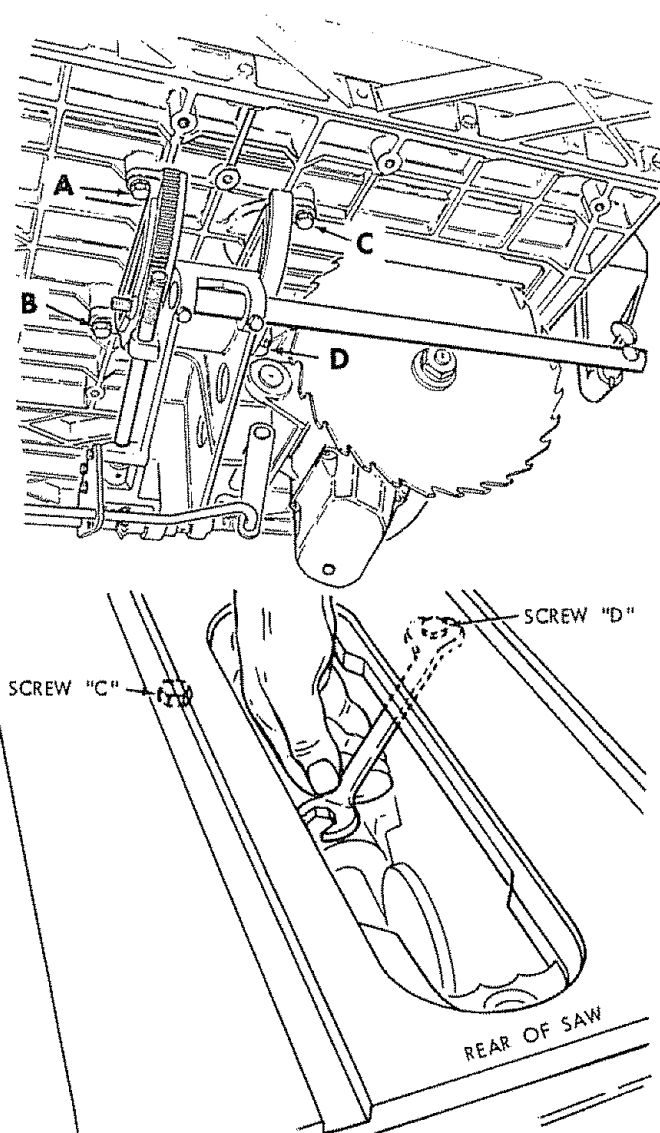

BLADE TILT, OR SQUARENESS OF BLADE TO TABLE

90° (SQUARE) and 45° (BEVEL) STOP COLLARS.

When the bevel pointer is pointing directly to the "0" mark on the bevel scale, the sawblade should make a SQUARE cut 90° to the table.

To check for SQUARENESS:

WARNING: FOR YOUR OWN SAFETY, TURN SWITCH "OFF" AND REMOVE PLUG FROM POWER SOURCE OUTLET.

1. Raise blade all the way UP ... raise blade guard.
2. TILT blade a few degrees to the LEFT ... now tilt blade back to the RIGHT as far as it will go.
3. Place ACCURATE square against blade. Make sure square is not touching the TIP of one of the saw TEETH.

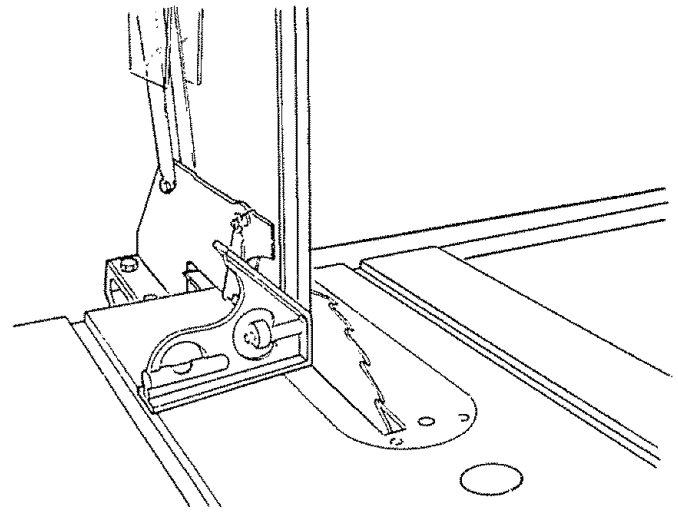

If blade IS SQUARE to table;

- A. Check pointer

If POINTER DOES NOT point to the "0" mark on the bevel scale;

- B. Loosen screw and adjust pointer ... using medium screwdriver.

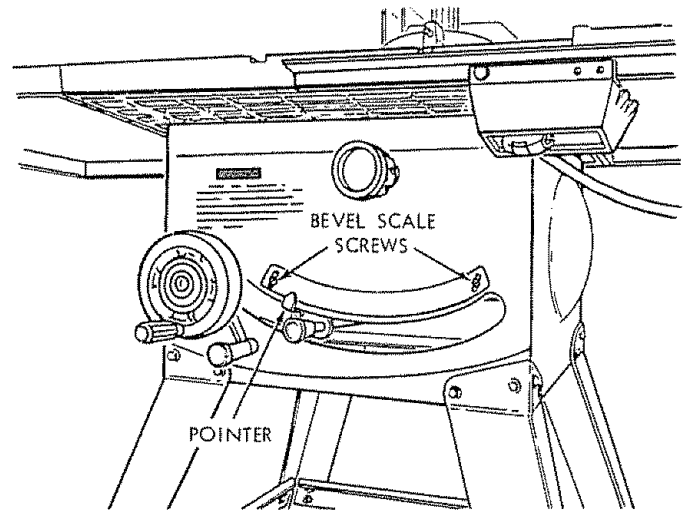

If blade is NOT SQUARE to table ... the 90° stop screw must be ADJUSTED.

1. Unscrew 90° STOP SCREW three to four turns using 3/16 in. setscrew wrench.
2. Tilt blade so that it is square with table.
3. Screw 90° stop screw IN until it stops ... check once again for squareness and readjust screw, if necessary.
4. Check POINTER ... readjust, if necessary.
5. Tilt blade to 45° and adjust 45° STOP SCREW the same way.
6. Check POINTER.

If POINTER DOES NOT point to the 45° mark on the bevel scale.

- A. Loosen the two screws and adjust bevel scale until POINTER points to 45° mark on scale.

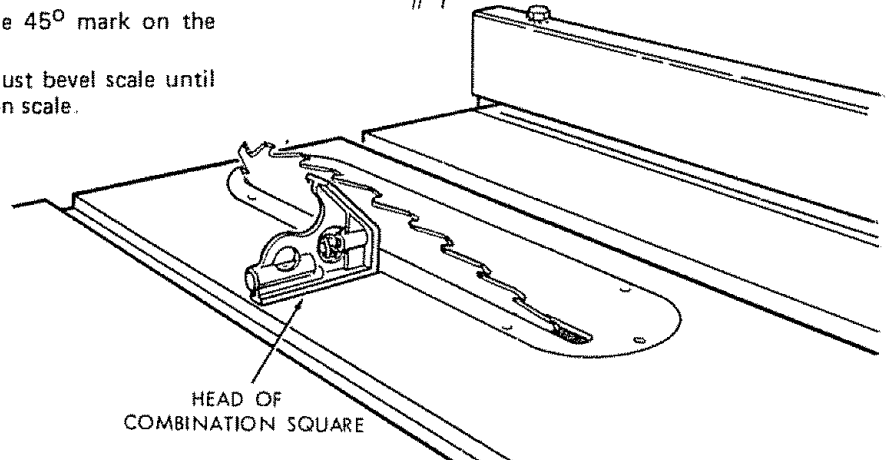
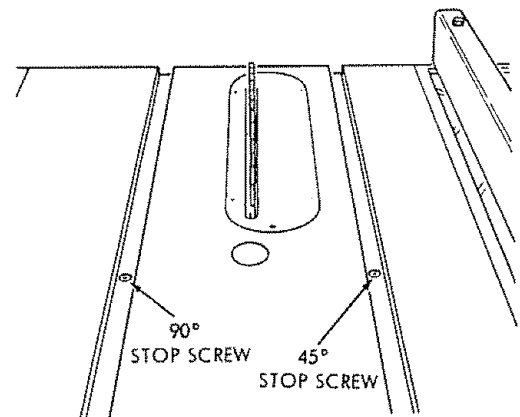

ELEVATION LOCK

When correctly adjusted, the elevation mechanism is locked securely when the ELEVATION LOCK KNOB is approx. one inch from the front of the saw.

After extended use, the ELEVATION LOCK SCREW and NUT may wear, which will cause the lock to slip.

1. Tilt blade to 45°.
2. Remove retaining screw, using a 3/8 in. wrench.
3. Move LOCK WRENCH in the direction of the arrow (this will tighten the LOCK NUT) only enough to replace the retaining screw in the next hole.
4. If retaining screw is in last hole as shown, lift LOCK WRENCH off of LOCK NUT and reposition it by rotating it CLOCKWISE.

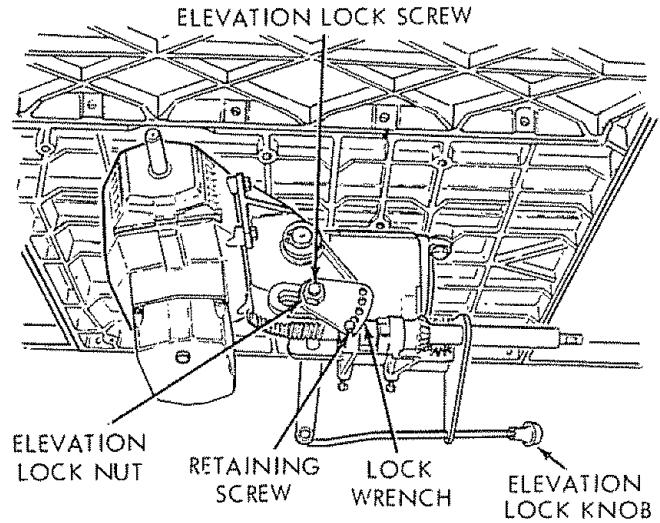

MAINTENANCE

WARNING: FOR YOUR OWN SAFETY, TURN SWITCH "OFF" AND REMOVE PLUG FROM POWER SOURCE OUTLET BEFORE MAINTAINING OR LUBRICATING YOUR SAW.

Do not allow sawdust to accumulate inside the saw.

Frequently blow out any dust that may accumulate inside the saw cabinet and the motor.

Frequently clean your cutting tools with Craftsman Gum and Pitch Remover.

A coat of automobile-type wax applied to the table and the rip fence guide bar will help to keep the surfaces clean and allow workpieces and the fence to slide more freely.

If the power cord is worn or cut, or damaged in any way, have it replaced immediately.

Make sure the teeth of the ANTIKICKBACK pawls are always sharp. To sharpen:

1. Remove blade guard.
2. Rotate pawl toward rear of spreader so that teeth are above top of spreader.
3. Hold spreader with left hand and place pawl over corner of workbench.
4. Using a small round file (Smooth Cut) sharpen the teeth.

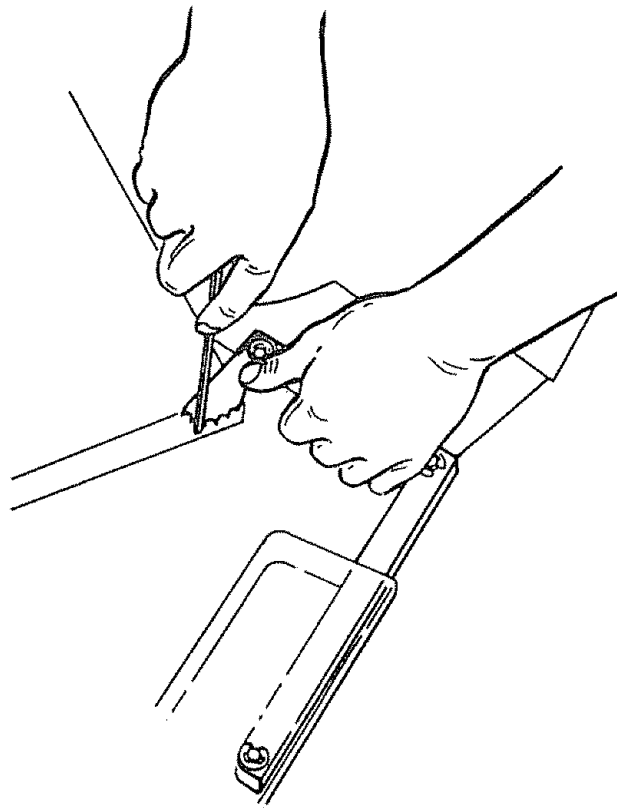

LUBRICATION

The saw motor bearings have been packed at the factory with proper lubricant and require no additional lubrication.

1. Lay the saw on its LEFT SIDE.
2. Clean the following parts with Craftsman Gum and Pitch Remover; BEVEL GEARS, ELEVATION WORM AND TEETH, TILT WORM AND TEETH.

Lubricate these parts and other bearing points indicated, with SAE No. 20 or No. 30 engine oil.

The following parts should be oiled occasionally with SAE No. 20 or No. 30 engine oil.

Bearing points in guard assembly and rip fence.

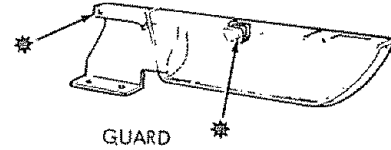

GUARD

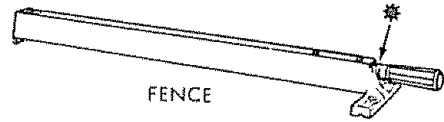

FENCE

* BEARING POINTS

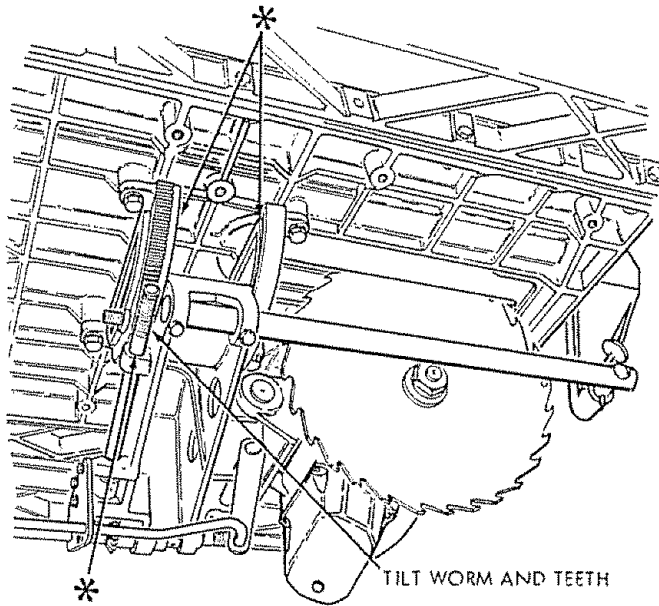

TILT WORM AND TEETH

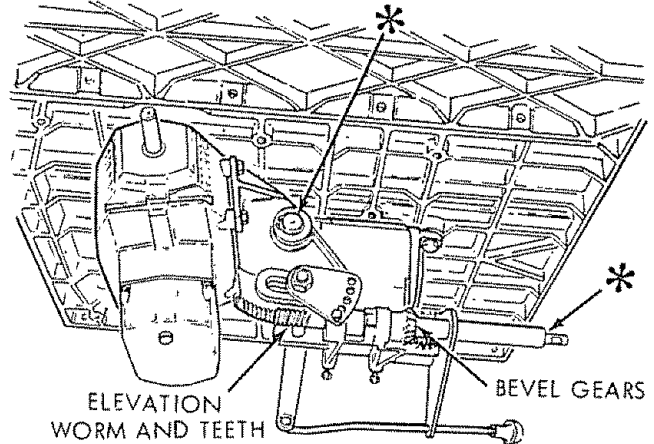

ELEVATION WORM AND TEETH

BEVEL GEARS

RECOMMENDED ACCESSORIES

ITEM	CAT. NO.	ITEM	CAT. NO.
Casters	9-22222 or 9-22221	7 In. Dia. Dado Head	9-3257
7 In. Molding Head Set	9-3217	Sanding Wheel	9-22723
7 In. Molding Head Set	9-3218	Miter-Gauge Stop Rods	9-29924
7 In. Molding Head	9-3214	Miter-Gauge Hold-Down Clamp	9-29928
Dado/Molding Insert for 7 in. Dia. Molding or Dado Head	9-29997	Taper Jig	9-3233
Work Light	9-2480	Universal Jig	9-3235
Work Light	9-2481	Power Tool Know How Handbook Table Saw	9-2918
7 In. Dia. Adjustable Dado Head	9-3263		

TROUBLE SHOOTING

WARNING: FOR YOUR OWN SAFETY, TURN SWITCH "OFF" AND ALWAYS REMOVE PLUG FROM POWER SOURCE OUTLET BEFORE TROUBLESHOOTING.

TROUBLE SHOOTING -- GENERAL

TROUBLE	PROBABLE CAUSE	REMEDY
Excessive vibration.	<ol style="list-style-type: none"> 1. Blade out of balance. 2. Failure to tighten Tilt Lock Knob. 	<ol style="list-style-type: none"> 1. Discard Blade and use a different blade. 2. See "Getting To Know Your Saw" section, "Tilt Lock Knob"
Cannot make square cut when crosscutting.	<ol style="list-style-type: none"> 1. Miter gauge not adjusted properly. 	<ol style="list-style-type: none"> 1. See "Adjustments" section "Miter Gauge".
Cut binds, burns or stalls motor when ripping.	<ol style="list-style-type: none"> 1. Dull blade with improper tooth set. 2. Blade is Heeling. 3. Warped board. 4. Rip fence not parallel to blade. 5. Spreader out of alignment 	<ol style="list-style-type: none"> 1. Sharpen or replace blade. 2. See "Adjustments" section, "Heeling Adjustments . . ." 3. Make sure concave or hollow side is facing "down," feed slowly. 4. See "Assembly" section, "Aligning Rip Fence" 5. See "Assembly" section, "Installing Blade Guard."
Cut not true at 90° or 45° positions.	<ol style="list-style-type: none"> 1. Stop screws not properly adjusted. 	<ol style="list-style-type: none"> 1. See "Adjustments" section, "Blade Tilt, or Squareness Blade to Table."
Tilt crank and elevation hand-wheel turn hard.	<ol style="list-style-type: none"> 1. Tilt lock knob not loosened when making tilt adjustment. 2. Gears worms and teeth clogged with sawdust. 	<ol style="list-style-type: none"> 1. See "Getting To Know Your Saw" section, "Tilt Lock Knob." 2. See "Lubrication" section.

TROUBLE SHOOTING -- MOTOR

NOTE: Motors used on wood-working tools are particularly susceptible to the accumulation of sawdust and wood chips

and should be blown out or "vacuumed" frequently to prevent interference with normal motor ventilation.

TROUBLE	PROBABLE CAUSE	REMEDY
Excessive noise.	<ol style="list-style-type: none"> 1. Motor. 	<ol style="list-style-type: none"> 1. Have motor checked by qualified service technician. Repair service is available at your nearest Sears store.
Motor fails to develop full power. (Power output of motor decreases rapidly with decrease in voltage at motor terminals. For example, a reduction of 10% in voltage causes a reduction of 19% in maximum power output of which the motor is capable, while a reduction of 20% in voltage causes a reduction of 36% in maximum power output.)	<ol style="list-style-type: none"> 1. Circuit overloaded with lights, appliances and other motors. 2. Undersize wires or circuit too long. 3. General overloading of power company facilities. (In some sections of the country, demand for electrical power may exceed the capacity of existing generating and distribution systems.) 4. Incorrect fuses or circuit breakers in power line. 	<ol style="list-style-type: none"> 1. Do not use other appliances or motors on same circuit when using the saw. 2. Increase wire sizes, or reduce length of wiring. See "Motor Specification and Electrical Requirements" section. 3. Request a voltage check from the power company. 4. Install correct fuses or circuit breakers.



TROUBLE SHOOTING -- MOTOR (Continued)

TROUBLE	PROBABLE CAUSE	REMEDY
Motor starts slowly or fails to come up to full speed.	<ol style="list-style-type: none"> 1. Low voltage will not trip relay. 2. Windings burned out or open. 3. Starting relay not operating. 	<ol style="list-style-type: none"> 1. Request voltage check from the power company. 2. Have motor repaired or replaced. 3. Have relay replaced.
Motor overheats.	<ol style="list-style-type: none"> 1. Motor overloaded 2. Improper cooling. (Air circulation restricted through motor due to sawdust, accumulating inside of saw). 	<ol style="list-style-type: none"> 1. Feed work slower into blade. 2. Clean out sawdust to provide normal air circulation through motor. See "Maintenance and Lubrication" section.
Starting relay in motor will not operate.	<ol style="list-style-type: none"> 1. Burned relay contacts (due to extended hold-in periods caused by low line voltage, etc.) 2. Shorted capacitor (when equipped) 3. Loose or broken connections. 	<ol style="list-style-type: none"> 1. Have relay replaced and request a voltage check from the power company. 2. Test capacitor and replace if defective. 3. Have wiring checked and repaired.
Motor stalls (resulting in blown fuses or tripped circuit breakers).	<ol style="list-style-type: none"> 1. Starting relay not operating. 2. Voltage too low to permit motor to reach operating speed. 3. Fuses or circuit breakers do not have sufficient capacity. 	<ol style="list-style-type: none"> 1. Have relay replaced. 2. Request voltage check from the power company. 3. Install proper size fuses or circuit breakers.
Frequent opening of fuses or circuit breakers.	<ol style="list-style-type: none"> 1. Motor overloaded. 2. Fuses or circuit breakers do not have sufficient capacity. 3. Starting relay not operating (motor does not reach speed). 	<ol style="list-style-type: none"> 1. Feed work slower into blade. 2. Install proper size fuses or circuit breakers. 3. Have relay replaced

PARTS LIST FOR CRAFTSMAN 12-INCH MOTORIZED TABLE SAW
MODEL NUMBER 113.242502

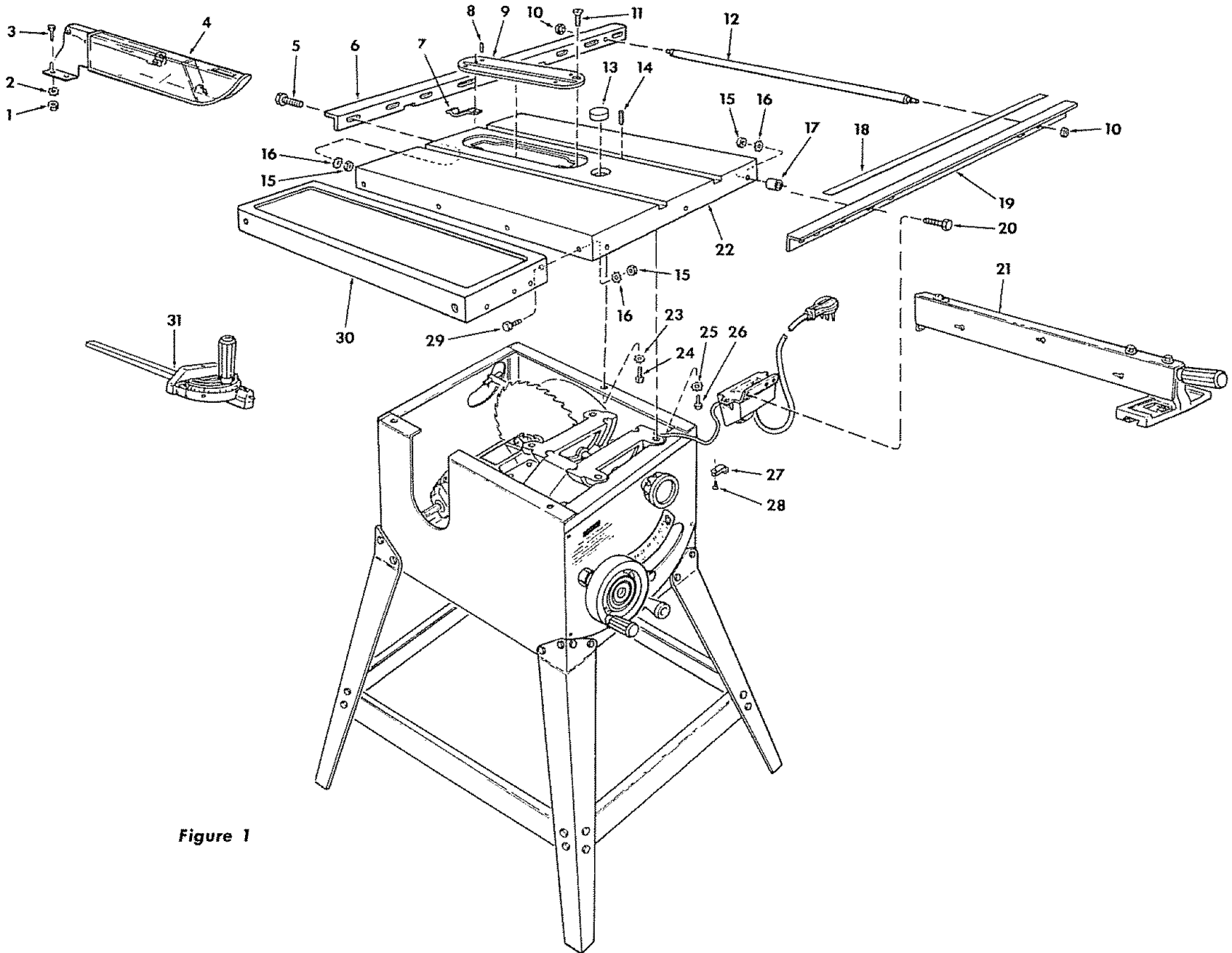

Figure 1

REPAIR PARTS

**PARTS LIST FOR CRAFTSMAN 12-INCH MOTORIZED TABLE SAW
MODEL NUMBER 113.242502**

Always order by Part Number – not by Key Number

FIGURE 1 PARTS LIST

Key No.	Part No.	Description
1	STD 541025	*Nut, Hex 1/4-20
2	STD 551225	*Lockwasher, External 1/4
3	STD 522506	*Screw, Hex Hd. 1/4-20 x 5/8
4	62594	Guard Assembly (See Figure 7)
5	STD 523110	*Screw, Hex Hd. 5/16-18 x 1
6	62541	Bar, Fence Rear
7	62718	Clip, Retaining
8	STD 501102	*Screw, Locking Set 10-32 x 3/16
9	62731	Insert Assembly (Includes Key No. 7 & 8)
10	60388	Nut, Self-threading
11	133645	Screw, Flat Hd. 10-32 x 1
12	62748	Rod, Separation (Includes Key No. 10)
13	62493	Insert, Exact-I-Cut
14	60122	*Screw, Soc. Set 3/8-16 x 7/8
15	STD 541031	*Nut, Hex 5/16-18
16	STD 551231	*Lockwasher, External 5/16
17	62539	Spacer, Fence Guide Bar

Key No.	Part No.	Description
18	62710	Tape, Fence
19	62709	Bar Assembly, Fence Guide (Includes Key No. 18)
20	STD 523117	*Screw, Hex Hd. 5/16-18 x 1-3/4
21	62773	Fence Assembly, Rip (See Figure 3)
22	62725	Table, Saw
23	STD 551237	*Lockwasher, External 3/8
24	454896	Screw, Hex Hd. 3/8-16 x 1/2
25	STD 551243	*Lockwasher, External 7/16
26	60127	Bolt, Hex Hd. 7/16-14 x 1
27	30613	Clamp, Cord
28	STD 600803	*Screw, Pan Hd. Ty. "T" 8-32 x 3/8
29	STD 523112	*Screw, Hex Hd. 5/16-18 x 1-1/4
30	62589	Extension, Table (See Figure 8)
31	62704	Gauge Assembly, Miter (See Figure 6)
—	62745	Bag of Loose Parts (Not Illustrated)
—	62746	Bag of Loose Parts (Not Illustrated)
—	62772	Owner's Manual (Not Illustrated)

*Standard Hardware Item – May be Purchased Locally.

PARTS LIST FOR CRAFTSMAN 12-INCH MOTORIZED TABLE SAW
MODEL NUMBER 113.242502

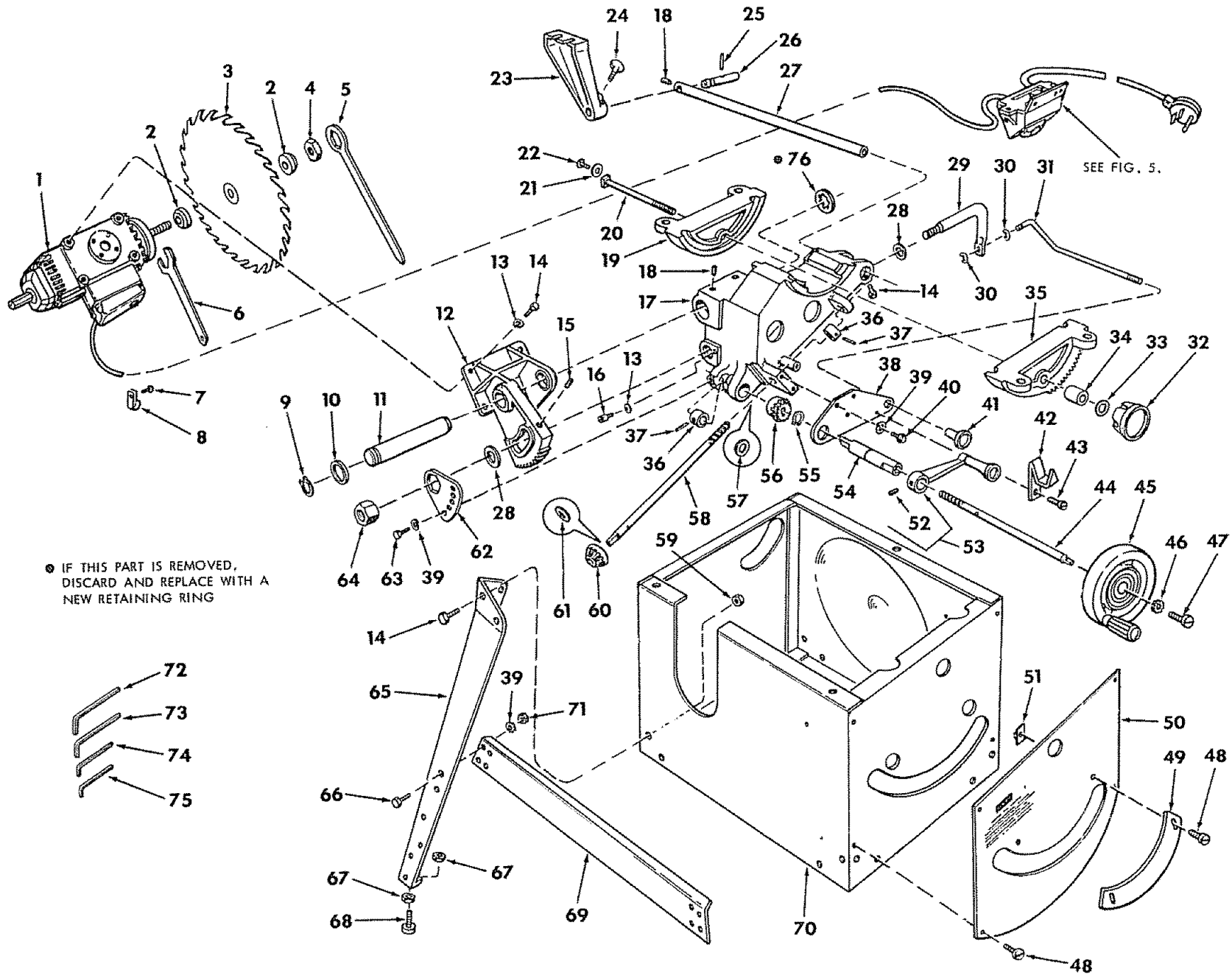

⊙ IF THIS PART IS REMOVED,
DISCARD AND REPLACE WITH A
NEW RETAINING RING

**PARTS LIST FOR CRAFTSMAN 12-INCH MOTORIZED TABLE SAW
MODEL NUMBER 113.242502**

FIGURE 2 PARTS LIST

Key No.	Part No.	Description
1	62743	Motor Assembly (See Fig. 4)
2	30494	Collar
3	60177	+Blade, Saw, 12" Chisel Tooth
4	6362	Nut, Saw Arbor
5	3540	Wrench, Arbor
6	63062	Wrench, Shaft
7	STD 600803	*Screw, Self-Tapping, No. 8-32 x 3/8", Pan Hd.
8	30613	Clamp, Cord
9	STD 582075	Ring, Retaining, 3/4"
10	62342	Washer, 25/32 x 1-3/8 x 1/8"
11	62756	Pin, Motor Pivot
12	62339	Support, Motor
13	STD 551231	*Lockwasher, 5/16"
14	STD 523106	*Screw, Hex Hd. 5/16-18 x 5/8"
15	STD 503705	*Screw, Set, 3/8-16 x 5/8", Hex. Soc. Flat Pt.
16	62093	Screw, Stop
17	62330	Cradle
18	STD 503103	*Screw, Set, 5/16-18 x 3/8", Hex. Soc. Cup Pt.
19	62098	Trunnion, Back
20	62100	Bolt, Sq. Hd. 3/8-16 x 7
21	STD 551012	*Washer, 7/32 x 1 x 1/16"
22	STD 601103	*Screw, Pan Hd. Type "T" 10-32 x 3/8"
23	62587	Support, Spreader
24	60204	Screw, Thumb 5/16-18 x 1
25	STD 571812	*Pin, Roll, 3/16 x 1-1/4"
26	62585	Rod, Spreader (Includes Key No. 25)
27	62218	Bar, Spreader
28	STD 551050	*Washer, 17/32 x 1-1/4 x 3/32"
29	62094	Screw, Lock
30	STD 581031	Ring, Retaining 5/16
31	62097	Rod, Lock Screw Push
32	62331	Knob Assembly, 2-1/4"
33	63011	Washer, Knob Clamp
34	62101	Spacer
35	62099	Trunnion, Front
36	62086	Collar
37	STD 571810	*Pin, Roll, 3/16 x 1"
38	62090	Plate, Bearing
39	STD 551225	*Lockwasher, 1/4"

Key No.	Part No.	Description
40	STD 522506	*Screw, Hex. Hd. 1/4-20 x 5/8"
41	62332	Knob Assembly, Pull
42	62726	Indicator, Tilt
43	STD 511002	*Screw, Pan Hd.
44	62727	Worm, Elevating
45	62689	Handwheel Assembly
46	STD 551210	*Lockwasher, External No. 10
47	STD 511107	*Screw, Pan Hd. 10-32 x 3/4
48	STD 610805	*Screw Type "AB" Pan Hd. No. 8 x 1/2"
49	62730	Scale, Adjustable Bevel
50	62729	Panel, Front
51	60354	Nut, Speed No. 8
52	STD 502503	*Screw, Set, 1/4-20 x 5/16", Hex. Soc. Cup Pt.
53	62356	Crank Assembly, Tilt
54	62222	Shaft, Tilt
55	STD 582087	*Ring, Retaining 7/8
56	62221	‡Gear, Miter
57	60159	Washer, Spacing, 1-1/2 x .630 x .005 (Used to adjust end-play after installing Key No. 56, supplied 5 in a package)
58	62223	Worm, Tilt
59	STD 541031	*Nut, Hex., 5/16-18
60	62220	‡Gear, Miter
61	60160	Washer, Spacing, 1-1/2 x .875 x .005 (Used to adjust end-play after installing Key No. 60, supplied 5 in a package)
62	62096	Wrench, Lock
63	STD 522503	*Screw, Hex. Hd., 1/4-20 x 3/8"
64	62095	Nut, Height Lock
65	62460	Leg, Base
66	STD 522505	*Screw, Hex. Hd., 1/4-20 x 1/2"
67	STD 541250	*Nut, Hex., 1/2-13
68	803835	Foot, Leveling
69	62113	Stiffener, Leg
70	62728	Base, Saw
71	STD 541025	*Nut, Hex 1/4-20
72	30504	*Wrench, Hex "L", 3/16"
73	37837	*Wrench, Hex "L", 5/32"
74	30505	*Wrench, Hex "L", 1/8"
75	37836	*Wrench, Hex "L", 3/32"
76	60393	• Ring, Retaining 3/4"

*Standard Hardware Item – May be Purchased Locally.

+Stock Item – May be secured through the hardware departments of most Sears Retail Stores or Catalog Order Houses.

‡When replacing gear (Key 56), use spacing washers (Key 57) to adjust end-play.

‡When replacing gear (Key 60), use spacing washers (Key 61) to adjust end-play.

• If this part is removed, discard and replace with a new retaining ring.

**PARTS LIST FOR CRAFTSMAN 12-INCH MOTORIZED TABLE SAW
MODEL NUMBER 113.242502**

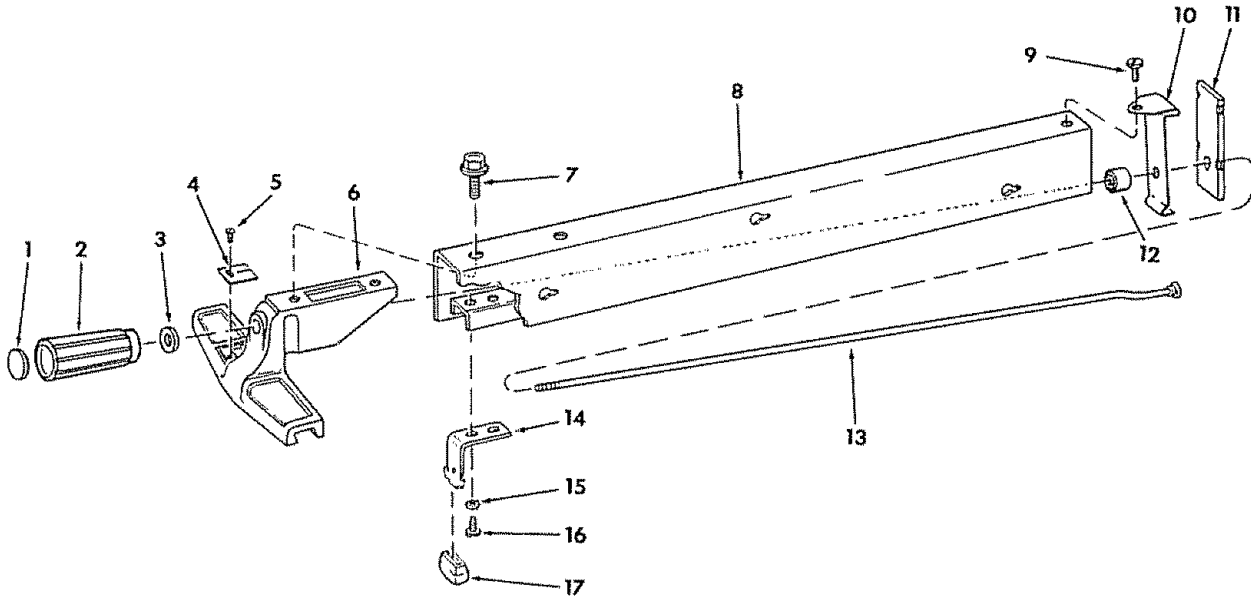

FIGURE 3 – 62773 FENCE ASSEMBLY

Key No.	Part No.	Description
—	62773	Fence Assembly, Rip
1	62693	Plug, Button
2	62692	Knob (Includes Key No. 1)
3	STD 551031	*Washer, 21/64 x 1/2 x 1/32
4	62775	Indicator, Fence
5	9404336	*Screw, Pan Hd. Type "T" 4-40 x 1/4
6	62774	Head, Fence
7	423350	Screws, Sems 3/8-16 x 1/2
8	62582	Channel, Fence
9	STD 600805	*Screw, Pan Hd. Type "T" 8-32 x 1/2
10	62528	Spring, Fence Lock
11	62529	Lock, Rear Fence
12	62531	Roller, Rear Fence
13	62583	Rod, Fence Lock
14	62533	Spring, Head Alignment (Includes #17)
15	STD 551210	*Lockwasher, External No. 10
16	STD 611005	*Screw, Pan Hd. Type "A" No. 10 x 1/2
17	62532	Pad, Alignment

*Standard Hardware Item – May be Purchased Locally.



**PARTS LIST FOR CRAFTSMAN 12-INCH MOTORIZED TABLE SAW
MODEL NUMBER 113.242502**

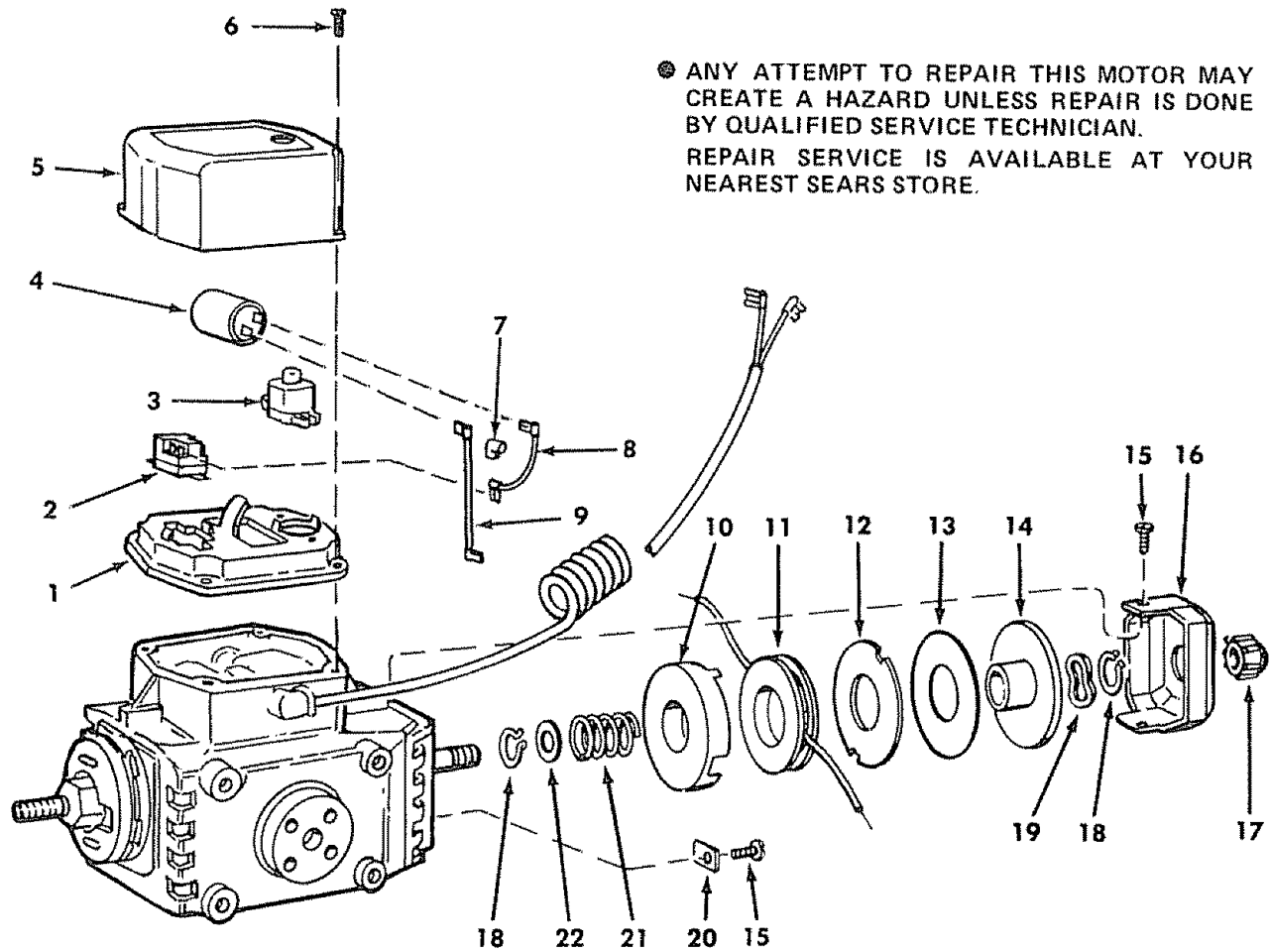

● ANY ATTEMPT TO REPAIR THIS MOTOR MAY
CREATE A HAZARD UNLESS REPAIR IS DONE
BY QUALIFIED SERVICE TECHNICIAN.
REPAIR SERVICE IS AVAILABLE AT YOUR
NEAREST SEARS STORE.

FIGURE 4 – 62743 MOTOR ASSEMBLY

Key No.	Part No.	Description
—	62743	Complete Motor Assembly
1	63798	Panel, Mounting
2	62245	Relay
3	62407	Protector
4	STD 376116	Capacitor
5	62749	Box Assembly, Panel w/ Nameplate
6	STD 600603	Screw, Pan Hd. Self-Tapping No. 6-32 x 3/8
7	63467	Cap, Flag Terminal
8	62265	Lead Assembly, Red 3" Long
9	62268	Lead Assembly, Red 6-1/2" Long
10	37908	Housing, Brake Coil

Key No.	Part No.	Description
11	63133	Coil, Brake
12	63134	Shoe, Brake
13	63137	Lining, Brake
14	37884	Disc, Brake
15	STD 600803	*Screw, Self-Tapping, No. 8-32 x 5/16", Pan Hd.
16	63309	Cover, Brake
17	30582	Cap, Shaft
18	37158	Ring, Retaining, 5/8"
19	37886	Washer, Spring
20	37412	Cleat
21	37415	Spring
22	30767	Washer, Spacer (As Required)

*Standard Hardware Item – May be Purchased Locally.

**PARTS LIST FOR CRAFTSMAN 12-INCH MOTORIZED TABLE SAW
MODEL NUMBER 113.242502**

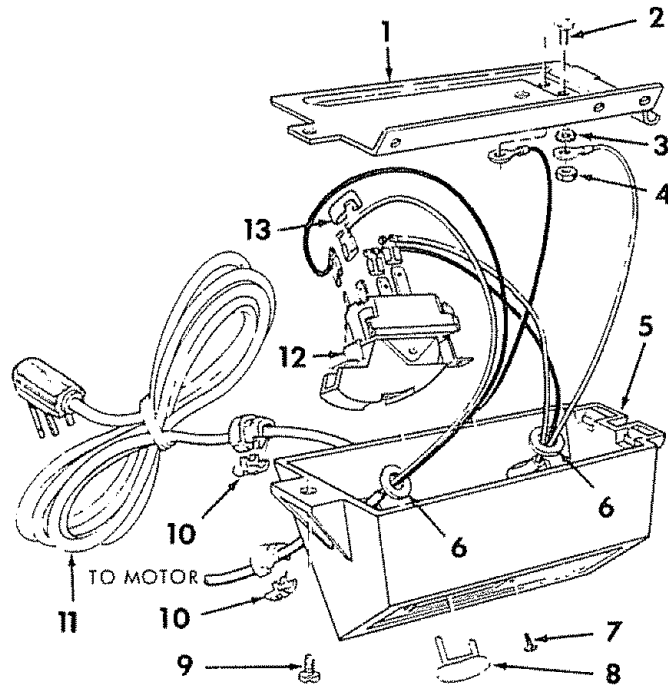

SEE WIRING DIAGRAM, PAGE 5

FIGURE 5 – SWITCH ASSEMBLY

Key No.	Part No.	Description
1	62466	Bracket, Housing
2	STD 601103	Screw, Type 23. 10-32 x 3/8", Pan Hd.
3	STD 551210	Lockwasher, External No. 10
4	STD 541110	Nut, Hex, 10-32 x 3/8 x 1/8"
5	62500	Box, Switch
6	37838	Washer, 5/8 x 7/8 x 1/64"
7	60287	Screw, Nylon, 6-32 x 5/16"
8	60256	Key
9	STD 611005	Screw, Type B No. 10 x 1/2"
10	37818	Relief, Strain
11	62613	Cord with Plug
12	60267	Switch
13	63467	Cap, Insulator

*Standard Hardware Item – May be Purchased Locally.



PARTS LIST FOR CRAFTSMAN 12-INCH MOTORIZED TABLE SAW
MODEL NUMBER 113.242502

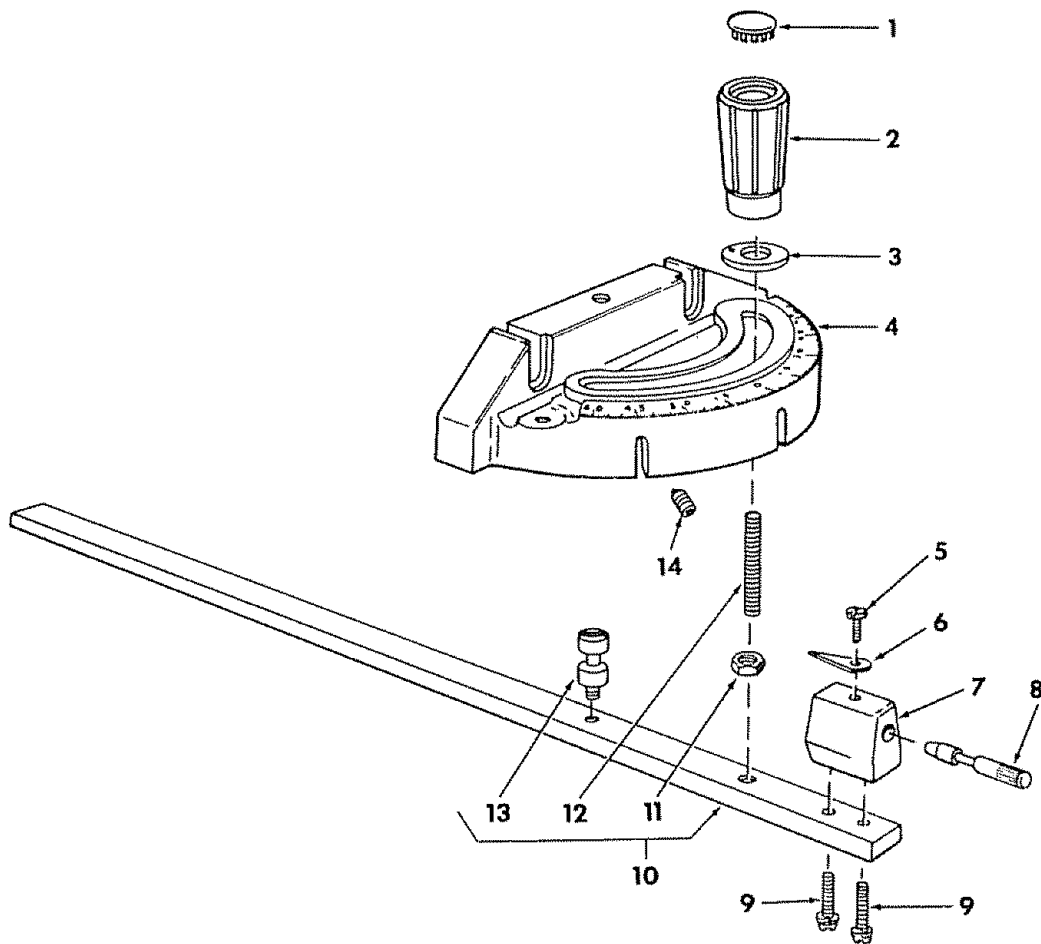

FIGURE 6 – 62704 MITER GAUGE ASSEMBLY

Key No.	Part No.	Description
—	62704	+Gauge Assembly, Miter
1	62693	Plug, Button
2	62692	Knob, Miter Gauge (Includes Key No. 1)
3	STD 551031	*Washer, Plain, 21/64 x 1 x 1/16"
4	37893	Gauge, Miter
5	STD 510803	*Screw, Pan Hd. 8-32 x 5/16"
6	135	Indicator
7	37895	Block, Miter Gauge Indicator
8	37896	Pin, Miter Gauge Stop
9	9417295	*Screw, Pan Hd., w/Lockwasher, 8-32 x 5/8"
10	62230	Rod Assembly, Miter Gauge, Consisting of Items 11, 12, 13
11	STD 541231	*Nut, Hex.. 5/16-18
12	62225	Stud, Clamp
13	62383	Stud, Pivot
14	60288	Screw, Locking Set, 1/4-20 x 3/8"

*Standard Hardware Item — May be Purchased Locally.

+Stock Item — May be secured through the Hardware Departments of most Sears Retail Stores or Catalog Order Houses.

PARTS LIST FOR CRAFTSMAN 12-INCH MOTORIZED TABLE SAW
MODEL NUMBER 113.242502

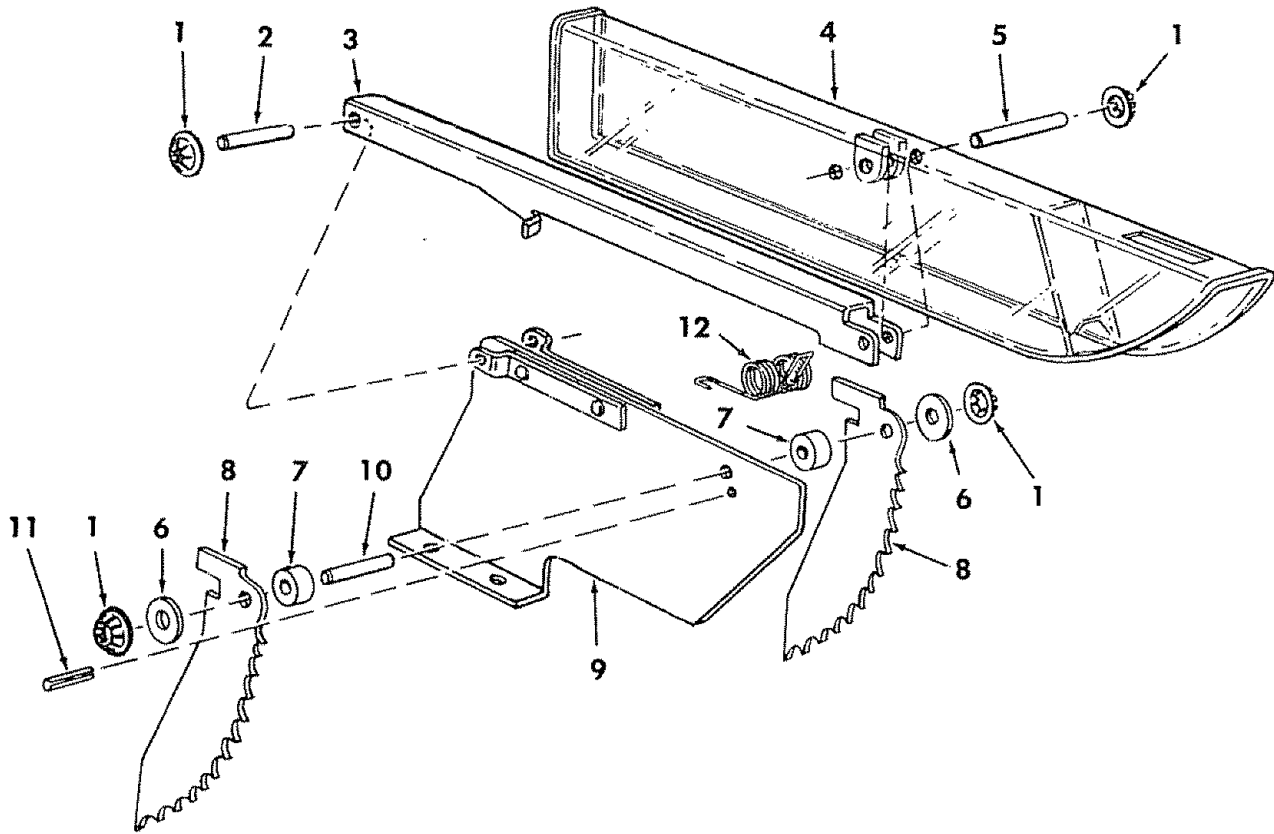

FIGURE 7 – 62594 GUARD ASSEMBLY

Key No.	Part No.	Description
	62594	Guard Assembly, Saw
1	60297	Nut, Push
2	62391	Pin 1/4 x 1-1/2"
3	62395	Support, Guard
4	62389	Guard, Saw
5	62390	Pin, 1/4 x 1-3/4"
6	STD 551025	*Washer, 17/64 x 5/8 x 1/16"
7	62520	Spacer, Pawl
8	62396	Pawl
9	62595	Spreader, Assembly Blade
10	62410	Pin, 1/4 x 1"
11	STD 571810	*Pin, Roll, 3/16 x 15/16"
12	62519	Spring, Pawl

* Standard Hardware Item – May Be Purchased Locally.

PARTS LIST FOR CRAFTSMAN 12-INCH MOTORIZED TABLE SAW
MODEL NUMBER 113.242502

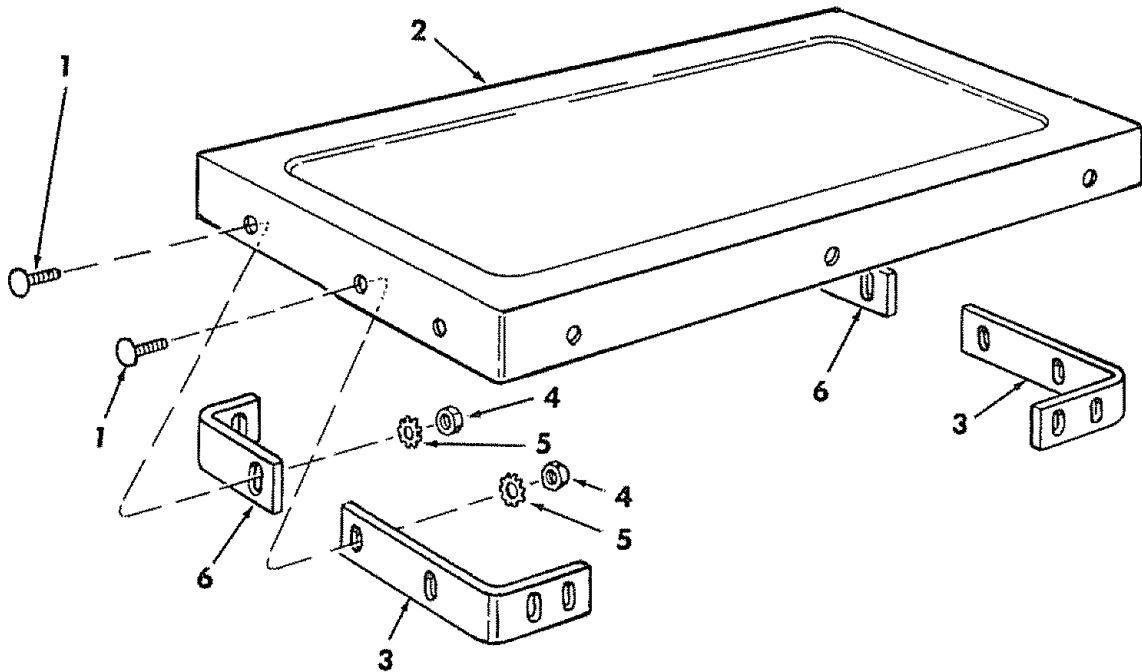

FIGURE 8 – 62589 TABLE EXTENSION

Key No.	Part No.	Description
—	62589	†Extension Assembly, Complete
1	60323	Screw, Serrated Truss Hd., 1/4-20 x 1"
2	62590	Extension
3	62549	Bracket, Corner Support
4	STD 541025	*Nut, Hex 1/4-20
5	STD 551225	*Lockwasher, Ext. 1/4
6	62550	Bracket, Corner Stiffener

*Standard Hardware Item – May be Purchased Locally.

†Stock Item – May be secured through the hardware departments of most Sears Retail Stores or Catalog Order Houses.



*owners
manual*

SERVICE

**MODEL NO.
113.242502**

**HOW TO ORDER
REPAIR PARTS**

**12 INCH MOTORIZED
TABLE SAW**

Now that you have purchased your 12-inch table saw, should a need ever exist for repair parts or service, simply contact any Sears Service Center and most Sears, Roebuck and Co. stores. Be sure to provide all pertinent facts when you call or visit.

The model number of your 12-inch table saw will be found on a plate attached to your saw, at the rear of the base.

WHEN ORDERING REPAIR PARTS, ALWAYS GIVE THE FOLLOWING INFORMATION:

PART NUMBER	PART DESCRIPTION
MODEL NUMBER 113.242502	NAME OF ITEM 12-INCH TABLE SAW

All parts listed may be ordered from any Sears Service Center and most Sears stores. If the parts you need are not stocked locally, your order will be electronically transmitted to a Sears Repair Parts Distribution Center for handling.

Sold by SEARS, ROEBUCK AND CO., Chicago, IL. 60684 U.S.A.

