

Refrigerated Beverage Dispensers

Thank you for purchasing this Vollrath equipment. Before operating the equipment, read and familiarize yourself with the following operating and safety instructions. **SAVE THESE INSTRUCTIONS FOR FUTURE REFERENCE.** Save the original box and packaging. Use this packaging to ship the equipment if repairs are needed.

SAFETY PRECAUTIONS

To ensure safe operation, read the following statements and understand their meaning. This manual contains safety precautions which are explained below. Please read carefully.

WARNING

Warning is used to indicate the presence of a hazard that will or can cause severe personal injury or death.

CAUTION

Caution is used to indicate the presence of a hazard that will or can cause minor or major personal injury if the caution is ignored.

NOTICE: Notice is used to note information that is important but not hazard-related.

To reduce risk of injury or damage to the equipment

- Plug only into grounded single-phase electrical outlets that match the voltage on the rating label.
- Do not use extension cords to connect the machine.
- Use this equipment in a flat, level position.
- Unplug machine before cleaning, performing maintenance or moving.
- Keep machine and power cord away from open flames, electric burners or excessive heat.
- Do not operate the machine unless all panels are secured with screws.
- Do not put objects or fingers in panels, louvers or spigot.
- Do not operate unattended.
- Closely supervise the machine when operating in public areas and/or around children.
- Do not operate the machine if it is damaged, malfunctioning or has damaged cord or plug.
- Use the machine with beverages as indicated in the **FUNCTION AND PURPOSE**.

FUNCTION AND PURPOSE

The Vollrath Refrigerated Beverage Dispensers are designed to refrigerate and serve pre-mixed cold beverages in commercial food service operations.

- Agitator and stirring paddle bowl circulation is suitable for most beverages and is recommended for beverages that can foam such as coffee, tea and natural fruit juices.
- Fountain spray bowl circulation is suitable for many beverages but is not recommended for beverages that can foam such as coffee, tea and natural fruit juices.
- These machines are NOT intended for use with beverages that include pieces of fruit, large pulp or seeds because these could block the spigot or mixing motor.
- They are not intended for outdoor, household, industrial or laboratory use.



| Item No. | Bowl Circulation | Capacity Gallon (Liter) | Number of Bowls |
|------------|------------------|-------------------------|-----------------|
| VBBC1-37-A | Agitator | 2.11 (8) | One |
| VBBC2-37-A | | | Two |
| VBBC3-37-A | | | Three |
| VBBC4-37-A | | | Four |
| VBBD1-37-S | Stirring Paddle | 3.17 (12) | One |
| VBBD2-37-S | | | Two |
| VBBD3-37-S | | | Three |
| VBBD4-37-S | | | Four |
| VBBE1-37-S | Stirring Paddle | 5.28 (20) | One |
| VBBE2-37-S | | | Two |
| VBBE3-37-S | | | Three |
| VBBE4-37-S | | | Four |
| VBBD1-37-F | Fountain Spray | 3.17 (12) | One |
| VBBD2-37-F | | | Two |
| VBBD3-37-F | | | Three |
| VBBD4-37-F | | | Four |
| VBBE1-37-F | Fountain Spray | 5.28 (20) | One |
| VBBE2-37-F | | | Two |
| VBBE3-37-F | | | Three |
| VBBE4-37-F | | | Four |

CLEARANCE AND ENVIRONMENT REQUIREMENTS

- Indoor use only.
 - Ambient temperature: 41° - 86°F (5° - 30° C).
 - Minimum clearance required: 6" (15.2 cm) on all sides of the machine.
-

INSTALLATION

NOTICE: Do not lay the machine on its side or back.

NOTICE: Do not lift the machine by the bowl(s). Only lift by grasping the bottom of the machine.

NOTICE: After unpacking the machine, it must sit in the upright position for 24 hours before turning it on. This will allow the oil in the compressor to settle into place.

Attach the Legs (Some Machines)

Some Refrigerated Beverage Dispensers require 4" (100 mm) legs to meet the NSF standard for cleaning under the machine. If legs are included with your machine, they must be installed.

1. Position the machine on a countertop capable of supporting the weight when all bowls are filled to capacity.
2. Replace the feet on the machine with installed with the 4" (100 mm) legs whenever they are provided with the machine.

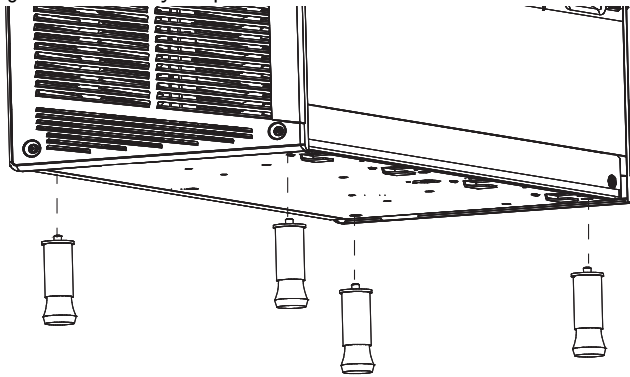

Attach the Drip Tray

Gently slide the drip tray into position until you hear it click.

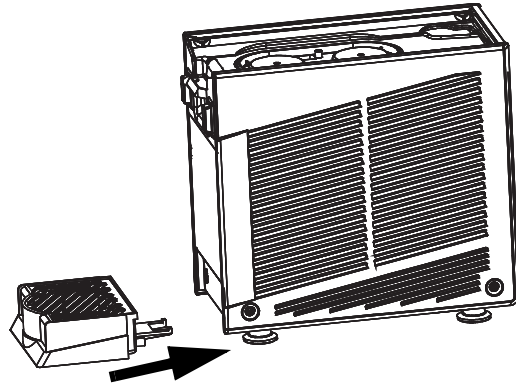

BEFORE FIRST USE

Before use, the machine must be disassembled, cleaned and sanitized.

1. Disassemble the machine. See **DISASSEMBLE THE MACHINE**.
2. Clean the components. See **CLEAN THE MACHINE**.
3. Re-assemble the machine. See **ASSEMBLE THE MACHINE**.
4. Sanitize the machine. See **CLEAN THE MACHINE**.

FEATURES AND CONTROLS

Machines with 2.11 Gallon Bowls

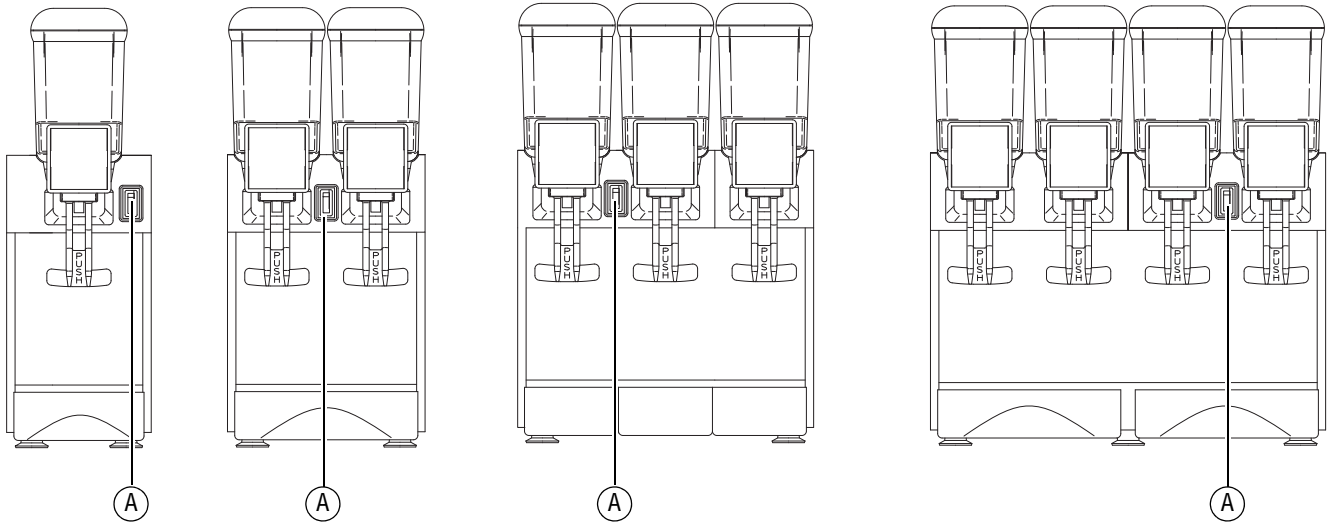

A ON/OFF Switch. Switches power, beverage circulation and refrigeration ON and OFF.

Machines with 3.17 and 5.28 Gallon Bowls

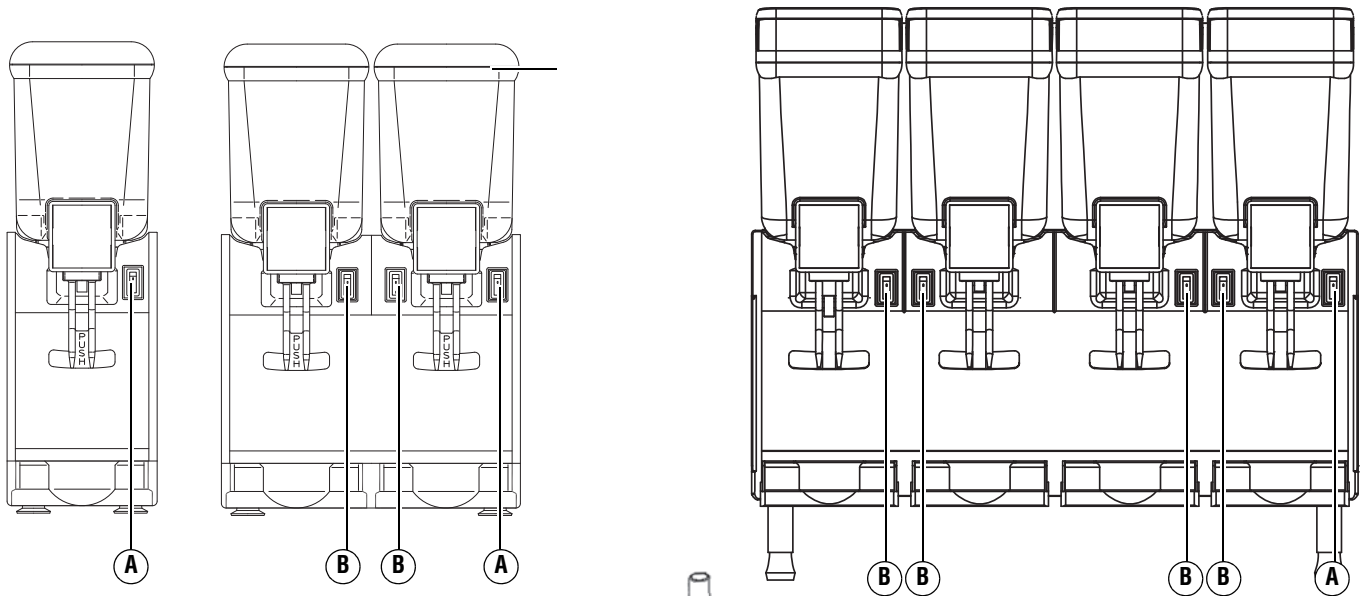

A ON/OFF. Switches power and refrigeration ON and OFF.

B Beverage Circulation ON/OFF. One per bowl. Switches the beverage circulation ON and OFF.

MAXIMUM AND MINIMUM FILL LEVELS

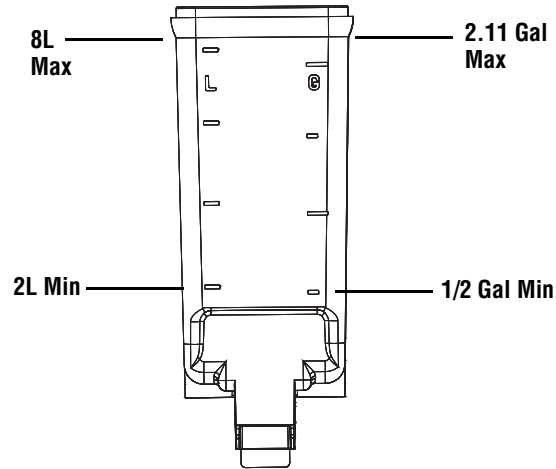

8 Liter Bowls

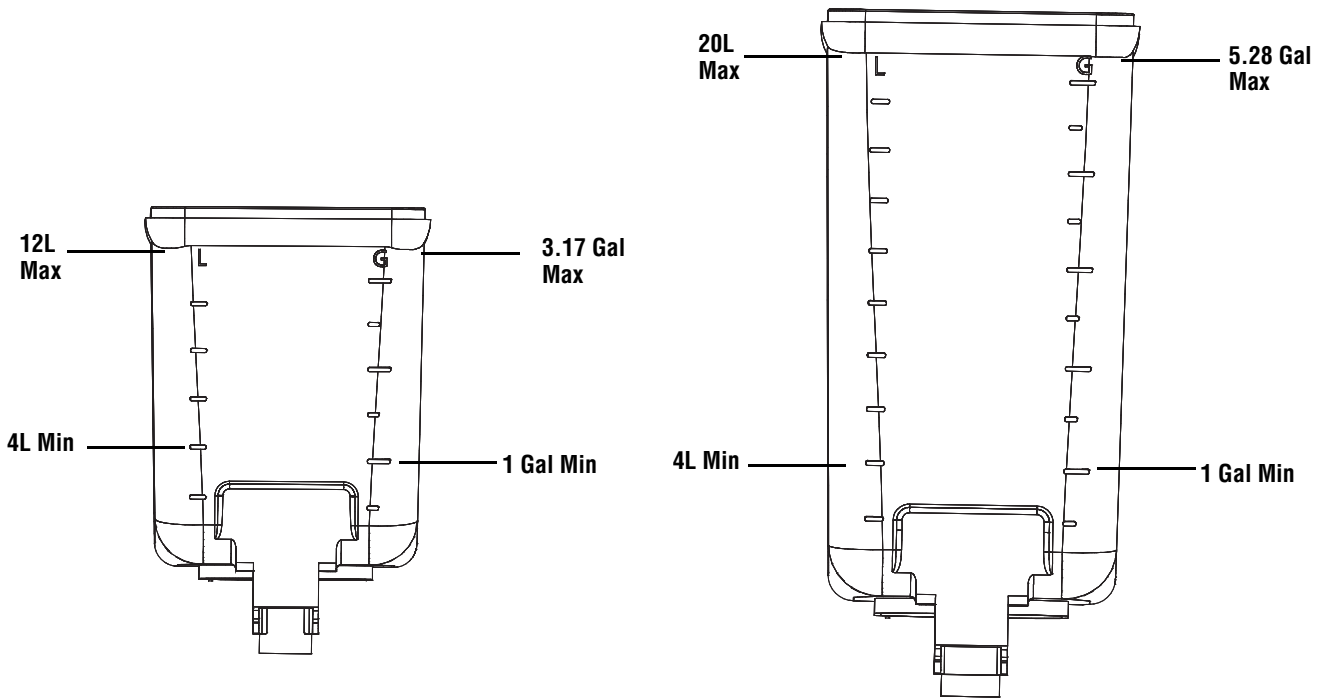

12 Liter Bowls

20 Liter Bowls

NOTICE: Do not exceed the maximum fill level.

NOTICE: Do not operate the machine when the beverage in the bowl is below the minimum fill level. Monitor the beverage level in each bowl. Add additional beverage as needed to maintain the minimum fill level.

OPERATION

NOTICE: Do not operate the machine unless all panels are secured with screws.

NOTICE: Do not put objects or fingers in panel louvers or spigot.

NOTICE: Unplug the machine before cleaning, troubleshooting or performing routine maintenance.

NOTICE: For best results pre-chill and mix the beverage before adding it to the dispenser.

NOTICE: Do not operate the machine with an empty bowl.

Sanitize the Machine

NOTICE: The United States Department of Agriculture and the Food and Drug Administration requires that all cleaning and sanitizing solutions used with food processing equipment be certified for this use.

NOTICE: Refer to local sanitary regulations for applicable codes and recommended sanitizing products and procedures. The frequency of sanitizing must comply with local health regulations.

Sanitizing must be done after the machine is cleaned and just before the machine is filled with beverage. Sanitizing the night before is not effective. However, you should always clean the machine and parts after using it.

1. Read the instructions for Stera-Sheen® Green Label Sanitizer or equivalent product for creating a 100 ppm strength solution.
2. Mix the sanitizer in warm, approximately 90° to 110°F (32° to 43°C) water.
3. Check the strength of the sanitizing solution. Use a chlorine test strip and color chart to make sure the solution has 100 ppm.
4. Pour the solution into the bowl.
5. Using a suitable brush, wipe the solution onto all parts above the level of the solution and on the underside of the cover.
6. Install the cover.
7. Plug in the machine.

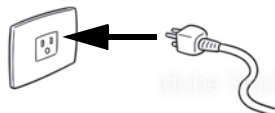

8. Turn on the machine.
9. Operate the machine for five minutes.
10. After five minutes, place a container under the spigot. Press the handle to drain the sanitizing solution. Do not discard the solution.
11. Use a new test strip to test the solution. A reading of 100 ppm or more is acceptable. If the reading is less than 100 ppm, sanitize the machine again.

NOTICE: If the reading is less than 100 ppm after sanitizing the second time, disassemble and wash the machine again.
12. When the strip shows a reading of 100 ppm or more, turn off the machine.

Add the Beverage

After sanitizing the machine, then add the beverage.

Note: When using a beverage mix, thoroughly combine the mix and the liquid before pouring into the bowl.

1. Remove the top cover from the bowl.
2. Flush any remaining sanitizer from the bowl by adding a small amount of beverage to the bowl. Then drain the beverage from the bowl.
3. Fill the bowl with beverage to at least the minimum fill level. Do not fill above the maximum fill level.
4. Place the cover on the bowl. If you do not wish to operate all of the bowls.

NOTICE: Do not operate the machine with an empty bowl. This may damage the impeller at the bottom of the bowl.

Machines with only one switch: Remove the impeller from the bottom of the bowl or fill the bowl with water.

Machines with a circulation switch for each bowl: Turn off circulation for the bowl that is not in use.

5. Turn on the machine.
 - Dispensers with 2.11 gallon bowls: Press the On/Off button.
 - Dispensers with 3.17 and 5.28 gallon bowls: Press the On/Off button to turn on refrigeration. Press the bowl circulation button for each bowl you wish to operate.
6. Allow the beverage to chill to the desired serving temperature.

Dispense Beverages

1. Press a cup against the dispenser lever to start the flow of the beverage.
2. Remove the cup to stop the flow of the beverage.

CLEAN THE MACHINE



WARNING

Electrical Shock Hazard

Before disassembly, ensure that the dispenser is disconnected from its power source.

NOTICE: Local and state health codes dictate the procedure required. Some health codes require a four-sink process (pre-wash, wash, rinse, sanitize, and air-dry), while other codes require a three-sink process (without the pre-wash step). The following procedure is a general guideline only. Consult your local and state health codes for procedures required in your location.

NOTICE: Hand wash only. Do not wash any components in the dishwasher.

NOTICE: Do not use excessive amounts of water around the electrical components. This could cause electric shocks or damage to the machine.

NOTICE: Do not use abrasive materials, scratching cleansers or scouring pads because these could damage the finish. Use only products designed for use with plastic.

Clean the Components

1. Drain any remaining beverage from the bowl.
2. Turn off and unplug the machine.

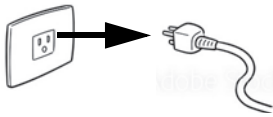

3. Disassemble the machine. See **DISASSEMBLE THE MACHINE** for instructions.

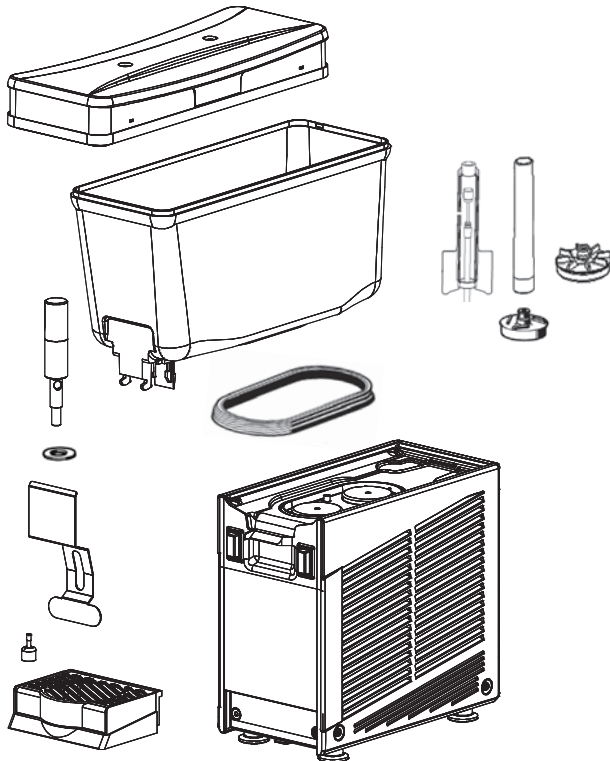

4. Wash the parts shown below in warm, 90° to 110°F (32°C to 43°C) mild detergent water.

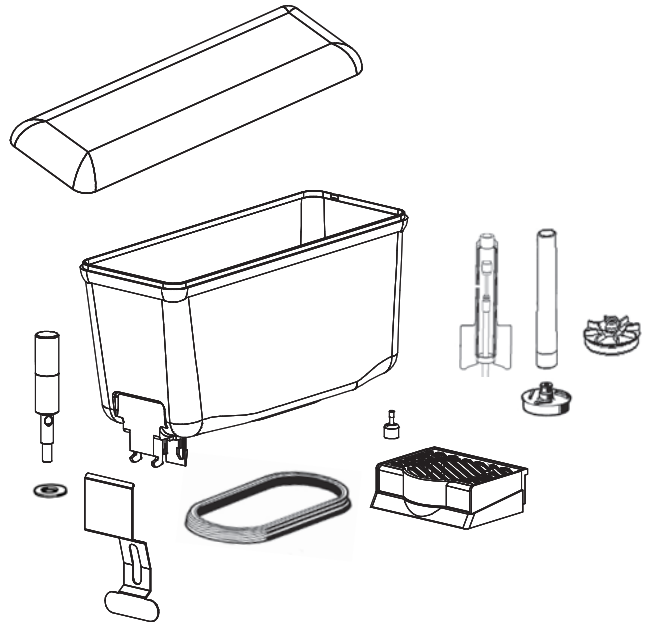

5. Rinse the components with clean 90° to 110°F (32°C to 43°C) water.
6. Place the components in a sanitizing solution for at least one minute.
7. Remove the components from the solution and let them air dry completely. Do not remove the sanitizer from the components.

DISASSEMBLE THE MACHINE



WARNING

Electrical Shock Hazard

Before disassembly, ensure that the dispenser is disconnected from its power source.

1. Turn off and unplug the machine.

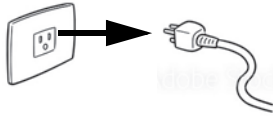

2. Remove the cover from the bowl.

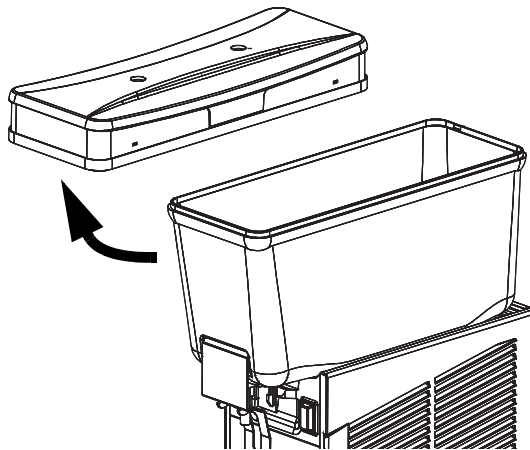

3. Remove the spigot by pushing on the dispensing handle while pulling the faucet up.

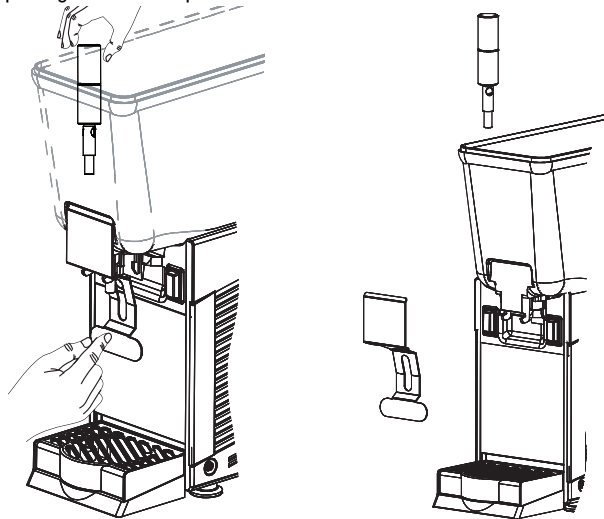

4. Remove the rubber washer from the spigot.

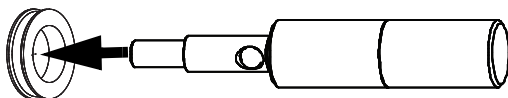

5. For stir and fountain models, remove the mixing components from the bowl.

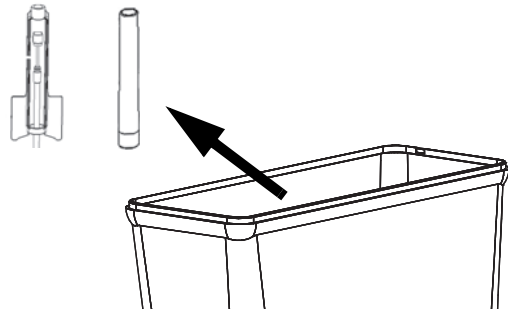

6. Remove the bowl by lifting up on the lever to release the bowl and lift it off of the gasket.

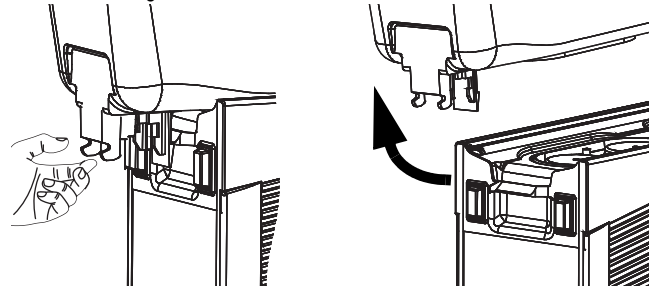

7. Remove the bowl gasket. For fountain and agitator models, also remove the impeller.

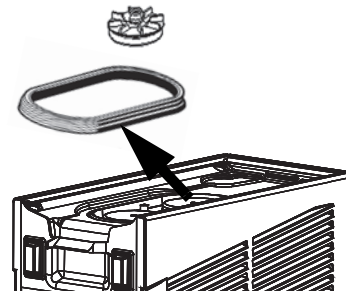

8. Slide the drip tray out and empty it.

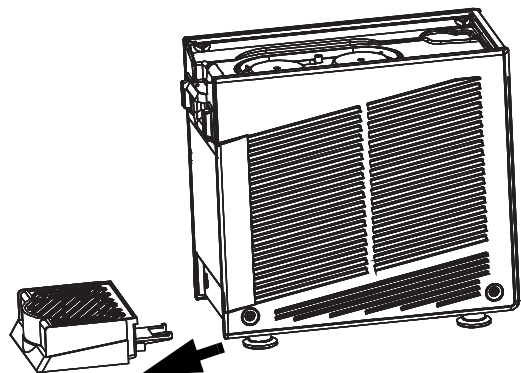

ASSEMBLE THE MACHINE

NOTICE: Clean, sanitize and allow all parts to air dry before assembling.

1. Make sure the machine is unplugged.

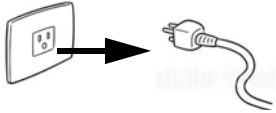

2. Attach the gasket. For fountain and agitator models, also install the impeller.

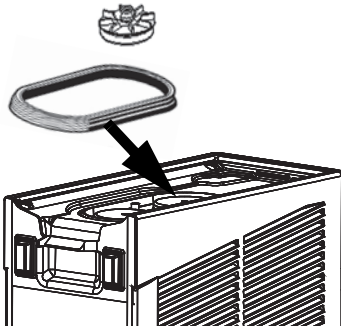

NOTICE: The wide rim of the gasket must be placed facing down.

3. Attach the bowl.

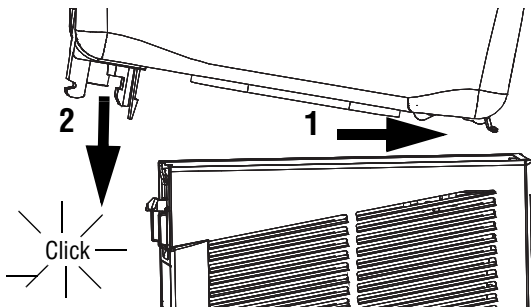

4. For stir and fountain models, insert the beverage circulating component(s).

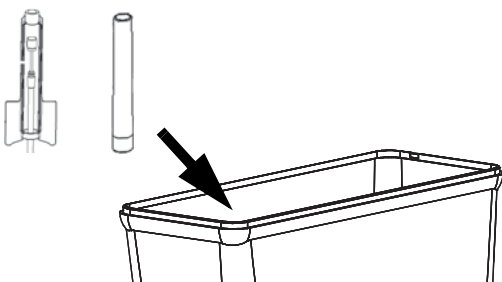

5. Install the washer onto the spigot. The flanges must be on the outside of the washer when it is installed.

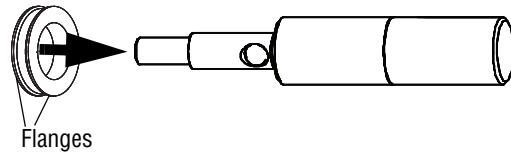

6. Attach the dispensing handle. Then while pressing the handle, slide the spigot into position in the bowl.

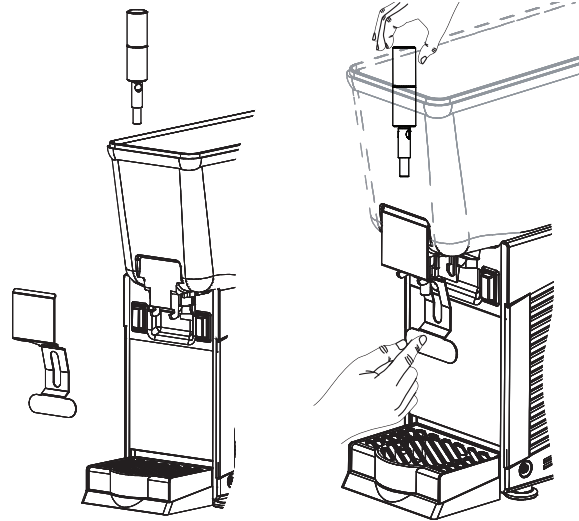

7. Slide the drip tray into the base until you hear it click into place.

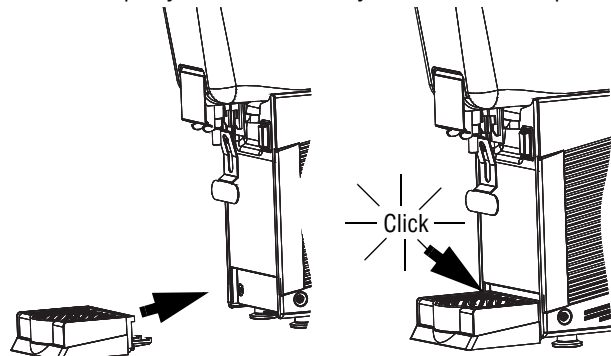

8. Place the cover on the bowl.

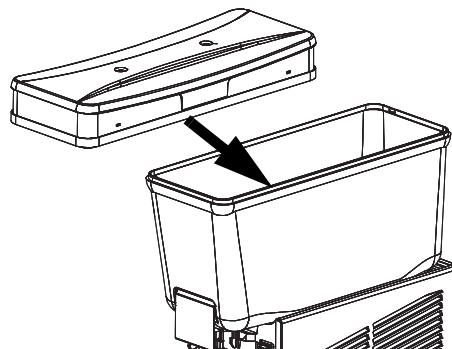

TROUBLESHOOTING

| Problem | Might be Caused By | Course of Action |
|---|---|--|
| It takes too long for the beverage to chill to desired serving temperature. | Beverage was not chilled before pouring it into the bowl. | Chill beverages before pouring into the bowl. |
| | Airflow is blocked. | Machine does not have enough clearance or the environment is not correct. See CLEARANCE AND ENVIRONMENT REQUIREMENTS . |
| | Condenser fins may be dirty. | Refer to CLEAN THE CONDENSER in this manual. |
| | Impeller may be dirty. | Inspect the impeller for food debris. Verify the impeller can freely rotate. |
| | Impeller may be damaged. | Replace the impeller. |
| Product is leaking from the machine. | Bowl may not be properly seated on the gasket. Gasket may be installed incorrectly. | Drain the bowl and reassemble the machine. See ASSEMBLE THE MACHINE . |
| | Rubber washer on the spigot may be installed incorrectly. | Drain the bowl. Remove the spigot. Verify the rubber is installed with the flanges to the outside of the gasket. See ASSEMBLE THE MACHINE . |
| | Gasket or rubber washer may be worn or damaged. | Replace the component. |
| | The ring on the piston hole in the bowl may be dirty, worn or damaged. | Drain the beverage from the bowl. Remove the bowl and inspect the piston hole at the bottom of the bowl for debris or wear. |
| Condensation on the bowl(s). | Ambient temperature is too warm or humidity is too high. | Cool the environment or relocate the machine. |
| | Beverage may be too thick. | Add liquid to thin the beverage. |
| Beverage not circulating well. (Stirring Paddle and Agitator machines) | Impeller may be dirty. | Turn off and unplug the machine. Remove the impeller from the bowl. Remove any food debris from the impeller or surrounding area. Food debris could impede the operation of the impeller and beverage circulation. |
| | Impeller may be damaged. | Replace the component. |

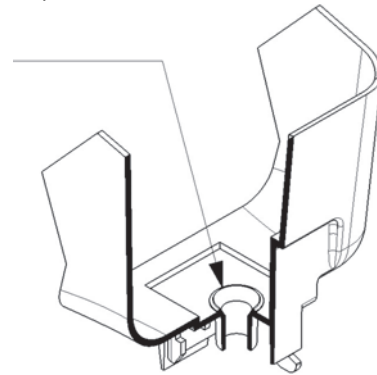
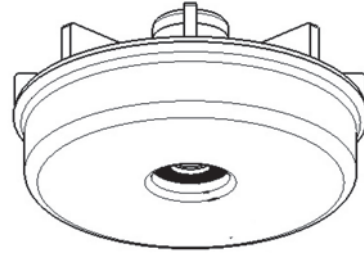

TROUBLESHOOTING

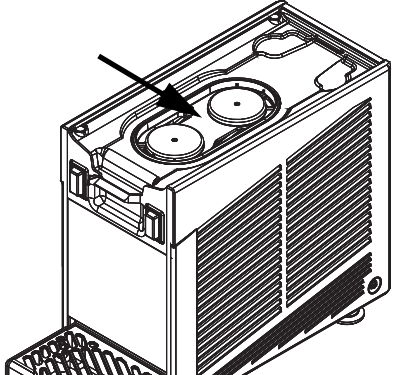
| Problem | Might be Caused By | Course of Action |
|---|---|---|
| Beverage not circulating well. (All machines) | Ice buildup on the evaporator plate due to operating the machine with less than the minimum amount of beverage in the bowl. | <p>Turn off the machine. Allow the ice to melt. Fill the bowl to above the minimum fill line. Resume operation.</p>  <p>Refer to the Minimum and Maximum Fill information in this manual. Monitor the amount of beverage in the bowl. Add beverage to the bowl as needed.</p> |
| Machine operation seems too loud. | The impeller on agitator or stirring paddle style machines may be damaged. | Inspect the impeller. Replace if it is damaged. |
| | A problem with the fan. | Contact Stoelting Technical Service. |

MAINTENANCE

Clean the Condenser (Monthly)

To keep your machine running properly, the condenser must be free of dust and dirt.

| | |
|--|----------------|
|  | WARNING |
| Electrical Shock Hazard | |
| Before disassembly, ensure that the dispenser is disconnected from its power source. | |

NOTICE: Compressed air must be used as shown below. Do NOT blow compressed air through the louvers and into the machine.

1. Turn off and unplug the machine.

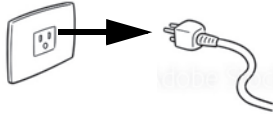

2. Remove the drip trays.



Machines with 2.11 Gallon Bowls

3. Remove the panel to access the condenser.



4. Remove the front panel.



5. Use compressed air to clean the condenser as shown below.



Machines with 3.17 and 5.28 Gallon Bowls

3. Remove the panel to access the condenser.



4. Remove one or both side panels.



5. Use compressed air to clean the condenser as shown below.



SERVICE AND REPAIR

Serviceable parts are available via Stoelting® Technical Service.

To avoid serious injury or damage, never attempt to repair the unit or replace a damaged power cord yourself. Do not send units directly to The Vollrath Company LLC. Please contact Stoelting Technical Service.

When contacting Stoelting please be ready with the item number, model number (if applicable), serial number, and proof of purchase showing the date the unit was purchased.

WARRANTY STATEMENT FOR THE VOLLRATH CO. L.L.C.

This warranty does not apply to products purchased for personal, family or household use, and The Vollrath Company LLC does not offer a written warranty to purchasers for such uses.

The Vollrath Company LLC warrants the products it manufactures or distributes against defects in materials and workmanship as specifically described in our full warranty statement. In all cases, the warranty runs from the date of the end user's original purchase date found on the receipt. Any damages from improper use, abuse, modification or damage resulting from improper packaging during return shipment for warranty repair will not be covered under warranty.

For complete warranty information, product registration and new product announcement, visit vollrathfoodservice.com.

VOLLRATH®

vollrathfoodservice.com

The Vollrath Company, L.L.C.

1236 North 18th Street
Sheboygan, WI 53081-3201 U.S.A.
Main Tel: 800.624.2051 or 920.457.4851
Main Fax: 800.752.5620 or 920.459.6573
Customer Service: 800.628.0830
Canada Customer Service: 800.695.8560

Stoelting Service

800.319.9549 (U.S. Toll Free)
920.894.2293 (Outside the U.S.)