

CORDLESS DRILL
ITEM NO.:47519



OWNER'S MANUAL AND SAFETY INSTRUCTIONS

SAVE THIS MANUAL: KEEP THIS MANUAL FOR SAFETY WARNINGS, PRECAUTIONS, ASSEMBLY, OPERATING, INSPECTION, MAINTENANCE AND CLEANING PROCEDURES. WRITE THE PRODUCT'S SERIAL NUMBER ON THE BACK OF THE MANUAL NEAR THE ASSEMBLY DIAGRAM (OR MONTH AND YEAR OF PURCHASE IF PRODUCT HAS NO NUMBER)

FOR QUESTIONS PLEASE CALL OUR CUSTOMER SUPPORT: 909.628.0880 MON-FRI 9AM TO 3PM PST

IMPORTANT SAFETY INFORMATION

WARNING

Read all safety warnings and instructions. Failure to follow the warnings and instructions may result in injury and/or property damage. Save all warnings and instructions for future reference. The warnings, precautions, and instructions discussed in this instruction manual cannot cover all possible conditions and situations that may occur. It must be understood by the operator that common sense and caution are factors which cannot be built into this product, but must be supplied by the operator.

WORK AREA SAFETY

- Keep work area clean and well lit. Cluttered or dark areas invite accidents.
- Do not operate power tools in explosive atmospheres, such as in the presence of flammable liquids, gases or dust. Power tools create sparks which may ignite the dust or fumes.
- Keep children and bystanders away while operating a power tool. Distractions can cause you to lose control.
- Use personal protective equipment. Always wear eye protection. Protective equipment such as dust mask, non-skid safety shoes, hard hat, or hearing protection used for appropriate conditions will reduce personal injuries.
- Prevent unintentional starting. Ensure the switch is in the off-position before connecting to power source and/or battery pack, picking up or carrying the tool. Carrying power tools with your finger on the switch or energising power tools that have the switch on invites accidents.

ELECTRICAL SAFETY

- Power tool plugs must match the outlet. Never modify the plug in any way. Do not use any adapter plugs with earthed (grounded) power tools. Unmodified plugs and matching outlets will reduce risk of electric shock.
- Avoid body contact with earthed or grounded surfaces, such as pipes, radiators, ranges and refrigerators. There is an increased risk of electric shock if your body is earthed or grounded.
- Do not expose power tools to rain or wet conditions. Water entering a power tool will increase the risk of electric shock.
- Do not abuse the cord. Never use the cord for carrying, pulling or unplugging the power tool. Keep cord away from heat, oil, sharp edges or moving parts. Damaged or entangled cords increase the risk of electric shock.
- When operating a power tool outdoors, use an extension cord suitable for outdoor use. Use of a cord suitable for outdoor use reduces the risk of electric shock.
- Remove any adjusting key or wrench before turning the power tool on. A wrench or a key left attached to a rotating part of the power tool may result in personal injury.
- Do not overreach. Keep proper footing and balance at all times. This enables better control of the power tool in unexpected situations.
- Dress properly. Do not wear loose clothing or jewellery. Keep your hair, clothing and gloves away from moving parts. Loose clothes, jewellery or long hair can be caught in moving parts.
- If devices are provided for the connection of dust extraction and collection facilities, ensure these are connected and properly used. Use of dust collection can reduce dust-related hazards.

POWER TOOL USE AND CARE

- Do not force the power tool. Use the correct power tool for your application. The correct power tool will do the job better and safer at the rate for which it was designed.
- Do not use the power tool if the switch does not turn it on and off. Any power tool that cannot be controlled with the switch is dangerous and must be repaired.
- Disconnect the plug from the power source and/or the battery pack from the power tool before making any

PERSONAL SAFETY

- Stay alert, watch what you are doing and use common sense when operating a power tool. Do not use a power tool while you are tired or under the influence of drugs, alcohol or medication. A moment of inattention while operating power tools may result in serious personal injury.

IMPORTANT SAFETY INFORMATION

GENERAL SAFETY RULES

adjustments, changing accessories, or storing power tools. Such preventive safety measures reduce the risk of starting the power tool accidentally.

- Store idle power tools out of the reach of children and do not allow persons unfamiliar with the power tool or these instructions to operate the power tool. Power tools are dangerous in the hands of untrained users.
- Maintain power tools. Check for misalignment or binding of moving parts, breakage of parts and any other condition that may affect the power tool's operation. If damaged, have the power tool repaired before use. Many accidents are caused by poorly maintained power tools.
- Keep cutting tools sharp and clean. Properly maintained cutting tools with sharp cutting edges are less likely to bind and are easier to control.
- Use the power tool, and accessories in accordance with these instructions, taking into account the working conditions and the work to be performed. Use of the power tool for operations different from those intended could result in a hazardous situation.
- This appliance is not intended for use by persons (including children) with reduced physical, sensory or mental capabilities, or lack of experience and knowledge, unless they have been given supervision or instruction concerning use of the appliance by a person responsible for their safety.
- Children should be supervised to ensure that they do not play with the appliance.

BATTERY TOOL USE AND CARE

- Ensure the switch is in the off position before inserting battery pack. Inserting the battery pack into power tools that have the switch on invites accidents.
- Recharge only with the charger specified by the manufacturer. A charger that is suitable for one type of battery pack may create a risk of fire when used with another battery pack.
- Use power tools only with specifically designated battery packs. Use of any other battery packs may create a risk of injury and fire.
- When battery pack is not in use, keep it away from other metal objects like paper clips, coins, keys, nails, screws, or other small metal objects that can make a connection from one terminal to another. Shorting the battery terminals together may cause burns or a fire.
- Under abusive conditions, liquid may be ejected from the battery; avoid contact. If contact accidentally occurs, flush with water. If liquid contacts eyes, additionally seek medical help. Liquid ejected from the battery may cause irritation or burns.

SERVICE

Have your power tool serviced by a qualified repair person using only identical replacement parts. This will ensure that the safety of the power tool is maintained.

ADDITIONAL SAFETY INSTRUCTIONS

WEAR EAR PROTECTORS.

Exposure to noise can cause hearing loss. Loss of control can cause personal injury.

- If possible, always use clamps or a vice to hold your work piece.
- Always switch off before you put the tool down.
- Ensure that the lighting is adequate.
- Do not put pressure on the tool, such that it slows the motor down.
- Keep the area free of tripping hazards.
- Do not let anyone under 18 years to operate this tool.
- Only use accessories in good condition.

- Do not touch the blade after operation. It will be very hot.
- Keep your hands away from under the workpiece.
- Never use your hands to remove sawdust, chips or waste close by the blade.
- Rags, cloths, cord, string and the like should never be left around the work area.
- Support the work properly.
- If you are interrupted when operating the tool, complete the process and switch off before looking up.
- Periodically check that all nuts, bolts and other fixings are properly tightened.

IMPORTANT SAFETY INFORMATION

ADDITIONAL SAFETY INSTRUCTIONS

- When using the tool, use safety equipment including safety glasses or shield, ear defenders, and protective clothing including safety gloves. Wear a dust mask if the cutting or sanding operation creates dust.

If in doubt, do not plug in the tool. Using a power source with a voltage less than the nameplate rating is harmful to the motor.

The tool must be used only for its prescribed purpose. Any use other than those mentioned in this Manual will be considered a case of misuse. The user and not the manufacturer shall be liable for any damage or injury resulting from such cases of misuse. To use this tool properly, you must observe the safety regulations, the assembly instructions and the operating instructions to be found in this Manual. All persons who use and service the machine have to be acquainted with this Manual and must be informed about its potential hazards.

Children and frail people must not use this tool. Children should be supervised at all times if they are in the area in which the tool is being used. It is also imperative that you observe the accident prevention regulations in force in your area. The same applies for general rules of occupational health and safety.

The manufacturer shall not be liable for any changes made to the tool nor for any damage resulting from such changes. Even when the tool is used as prescribed it is not possible to eliminate all residual risk factors. The following hazards may arise in connection with the tool's construction and design:

Damage to the lungs if an effective dust mask is not worn. Damage to hearing if effective ear defenders are not worn.

ADDITIONAL SAFETY INSTRUCTIONS FOR THE CHARGER

- **XTREMEPOWERUS** tool with Lithium Ion batteries should only be charged with the specifically designed **XTREMEPOWERUS** Lithium Ion battery charger purchased with the tool. **IT IS DANGEROUS TO USE ANY OTHER BATTERY CHARGER TO CHARGE YOUR TOOL.** Do not attempt to charge the battery pack with any other charger than the one supplied.
- Before using the charger, read all the instructions, labels and cautionary markings on the charger and battery pack as well as the instructions on using the battery pack.
- Do not use the charger if it has been subjected to a heavy knock, dropped or otherwise damaged in anyway. Take the charger to an authorized service center for a check or repair.
- Do not disassemble the charger. Opening or removing covers may expose you to dangerous voltages or other risks. Incorrect reassembly can cause electric shock when you use the tool or charger again. Take the charger to a power tool repair center when service or repair is required. Incorrect re-assembly may result in the risk of fire, electric shock or electrocution. To reduce the risk of electric shock, do not disassemble any part of the product.

DANGER

- If the battery pack is cracked or damaged in any way, do not insert it in the charger
- Do not plug anything other than your tool into the charger, as other objects may touch dangerous voltage points or short out parts, which could result in fire or electric shock.
- Do not place the tool or charger on an uneven surface, a fall may cause serious damage.
- Never place the tool or charger near or over a heat source such as a radiator or heater.
- Do not operate the charger in a cabinet or other enclosure unless proper ventilation is provided.
- Use the battery charger indoors only.

IMPORTANT SAFETY INFORMATION

ADDITIONAL SAFETY INSTRUCTIONS FOR THE CHARGER

WARNING!

- Do not allow any liquid to come into contact with the charger. There is a danger of electric shock. Do not position the tool or battery charger near water; for example, near a sink, wash bowl or toilet.
- Do not spill liquid of any kind on the tool or charger. Doing so may short out parts, causing damage to the product and creating the risk of fire or electric shock.
- To reduce the risk of an electric shock, unplug the charger from the power supply before attempting to clean it. To clean tool or charger, wipe with a damp cloth. Use of any other cleaners is not recommended.
- Do not place any object on to, or allow anything to rest on the charger.
- Make sure that the charger cable is positioned where it will not be stepped on, tripped over or otherwise subjected to damage or stress. Keep the lead away from operating machinery.
- Do not pull on the lead of the charger to disconnect it from the mains power socket.
- Do not use an extension cord unless it is absolutely necessary. The use of an improper extension cord could cause the risk of fire, electric shock or electrocution.
- Never attempt to connect two chargers together.
- Do not charge batteries or use the tool and battery pack in locations where the temperature may be below 0°C or exceed 40°C such as alongside sheds or metal structures.
- The battery can be charged or operated at temperatures between 0°C and 40°C.

NEVER CHARGE YOUR LITHIUM ION BATTERY BELOW OR ABOVE TEMPERATURES RECOMMENDED OTHERWISE FIRE OR SERIOUS DAMAGE TO THE BATTERY PACK MAY OCCUR.

WARNING!

If you wish to charge a second battery pack, unplug the charger from the mains supply and leave it for at least 15 minutes. After this time you can charge a second battery pack.

ADDITIONAL SAFETY INSTRUCTIONS RELATED TO THE BATTERY PACK AND BATTERY SAFETY

- Use only the XTREMEPOWERUS batteries supplied with the Tool or XTREMEPOWERUS -approved replacements.
- Do not use the battery to power any device other than the XTREMEPOWERUS tool it was sold with.
- Charge the battery only with the XTREMEPOWERUS chargers supplied with the tool or XTREMEPOWERUS -approved replacements and according to the instructions in the XTREMEPOWERUS Instruction Manual.
- Do not charge the battery in a place where static electricity is generated nor let the battery touch something that is statically charged.
- The battery can be stored at temperatures between 0°C and 40°C.

NEVER STORE OR LEAVE YOUR LITHIUM ION BATTERY IN TEMPERATURES OVER THAT RECOMMENDED OTHERWISE FIRE MAY OCCUR.

Do not store the Lithium Ion battery anywhere that the temperature can easily reach higher temperatures than recommended -this includes garden type sheds, and Vehicles where the inside temperature can climb to dangerous levels in the direct sunlight and on high temperature days.

- The battery can be charged or operated at temperatures between 0°C and 40°C.

NEVER STORE OR LEAVE YOUR LITHIUM ION BATTERY IN TEMPERATURES OVER THAT RECOMMENDED OTHERWISE FIRE MAY OCCUR.

IMPORTANT SAFETY INFORMATION

ADDITIONAL SAFETY INSTRUCTIONS RELATED TO THE BATTERY PACK AND BATTERY SAFETY

The most suitable temperatures to charge the battery pack are between 20 -25°C.

- Always allow the battery pack to cool down after charging, do not place it in a hot environment such as a metal shed or open trailer left in the sun.
- Take care where the tool is stored. Do not store in areas of corrosive fumes, or salt air or similar conditions. Try and store the tool in the packaging supplied with the tool.
- Do not dispose of the battery in a fire or put the battery into a microwave oven, conventional oven, dryer, or high-pressure container. Under these conditions, the battery may explode.
- Never attempt to open the battery pack, puncture the battery or subject the battery to strong physical shock.
- If the plastic housing of the battery pack breaks open or cracks, immediately discontinue its use and do not recharge it. Ensure the battery pack clip is in good condition and will not allow the pack to fall free from the tool. If the clip is damaged or for any reason is not locking the pack in place Do Not continue to use.
- Stop using the battery if it exhibits abnormal heat, odor, color, deformation, or is in an abnormal condition.
- If you detect leakage or a foul odor, it is especially important to keep the battery away from fire. If battery liquid leaks onto your skin or clothes, wash well with clean water immediately. If liquid leaking from the battery gets into your eyes, do not rub your eyes. Rinse your eyes well (for at least 10 minutes) with clean water, and consult a doctor immediately. Do not use a leaking battery.
- Handle batteries with care to avoid shorting the battery with conducting materials, such as nails, screws, metal watch bands, rings, bracelets, and keys. The battery may overheat and could burn you.
- After the battery has reached the end of its useful life, we recommend recycling the materials at your local municipal council recycling center. DO NOT attempt to replace the battery cells in the battery pack, repair or modify any part of the battery pack assembly.
- When recycling, make it non-conductive by applying insulating tape to the terminals located on the battery.

WHEN TO CHARGE THE BATTERY

New batteries are shipped in a low charged condition and should be fully charged before Use. The battery pack can be recharged at any time during use, provided the pack is not overheated. If the battery pack starts to cut out due to low voltage, or previous tasks undertaken can no longer be performed, it is suggested to stop using the tool and recharge the battery. For storage, it is suggested to recharge the battery between 50% and 75% charge.

WARNING!

Some dust created by power sanding, sawing, grinding, drilling and other construction activities contains chemicals known to the State of California to cause cancer, birth defects of other reproductive harm.

Some examples of these chemicals are:

- Lead from lead-based paints
- Crystalline silica from bricks and cement and other masonry products, and Arsenic and chromium from chemically-treated lumber.

Your risk from these exposures varies, depending on how often you do this type of work. To reduce your exposure to these chemicals: work in a well-ventilated area, and work with approved safety equipment, such as those dust masks that are specially designed to filter out microscopic particles.

IMPORTANT SAFETY INFORMATION

UNPACKING









- Unpack all parts and lay them on a flat, stable surface.
- Remove all packing materials and shipping devices, if applicable.
- Make sure the delivery contents are complete and free of any damage. If you find that parts are missing or show damage do not use the product but contact your dealer. Using an incomplete or damaged product represents a hazard to people and property.
- Ensure that you have all the accessories and tools needed for assembly and operation. This also includes suitable personal protective equipment.

WARNING!

The product and the packaging are not children's toys! Children must not play with plastic bags, sheets and small parts! There is a danger of choking and suffocation!

SYMBOLS

On the product, the rating label and within these instructions you will find among others the following symbols and abbreviations. Familiarize yourself with them to reduce hazards like personal injuries and damage to property.

V~	Volt, (alternating voltage)	mm	Millimetre
Hz	Hertz	kg	Kilogram
W	Watt	dB(A)	Decibel (A-rated)
/min or min⁻¹	Per minute		Caution / Warning.
	Note / Remark.		Wear hearing protection.
	Read the instruction manual.		Wear a dust mask.
	Wear eye protection.		Wear protective, slip-resistant footwear.
	Wear protective gloves.		



Switch the product off and disconnect it from the power supply before assembly, cleaning, adjustments, maintenance, storage and transportation.



The product complies with the applicable European directives and an evaluation method of conformity for these directives was done.



WEEE symbol. Waste electrical products should not be disposed of with household waste. Please recycle where facilities exist. Check with your Local Authority or local store for recycling advice.

DESCRIPTION



1. 10mm keyless chuck
2. Torque adjustment collar
3. 2-Speed gear control
4. Forward/Reverse rotation control
5. Soft grip handle

6. Battery pack release button
7. Battery pack
8. Variable speed switch
9. LED light
10. Battery capacity indicator

SPECIFICATION

Charger	100-240V ~ 50/60Hz
Battery	Lithium-ion 2.0 Ah
Charging time	around 1 hour
No-load speed	0-400 / 0-1500 rpm
Torque settings	18 + 1 + 1
Max. torque	25 N.M.
Chuck capacity	10mm keyless chuck
Max. drilling capacity for steel	6mm
Max. drilling capacity for wood	16mm

OPERATING INSTRUCTIONS FOR DRILL DRIVER

NOTE:

Before using the tool, read the instruction book carefully.

RECHARGEABLE BATTERY INSTALLATION/REMOVAL

Hold the handle tightly and push the battery latch (6) to remove the battery (see Fig.1)

INTENDED USE

The machine is intended for driving in and loosening screws as well as for drilling in wood, metal and plastic.

BEFORE PUTTING INTO OPERATION CHARGING THE BATTERY

The battery charger supplied is matched to the Li-ion battery installed in the machine. Do not use another battery charger. The Li-ion battery is protected against deep discharging. When the battery is empty, the machine is switched off by means of a protective circuit: The tool holder no longer rotates. In a warm environment or after heavy use, the battery pack may become too hot to permit charging. Allow time for the battery to cool down before recharging. When the battery pack is charged for the first time and after prolonged storage, the battery pack will accept a 100% charge after several charge and discharge cycles.

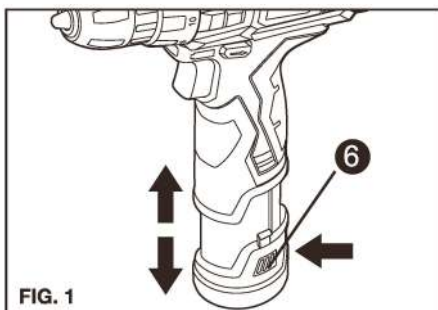

FIG. 1

Insert the battery while observing its direction. Do not apply too much force when installing the rechargeable battery. Check the correctness of its installation.

OPERATION

1. ON / OFF SWITCH (SEE FIG. 2)

Depress the On/Off switch (8) to start and release it to stop your drill. The on/off switch is fitted with a brake function which stops your chuck immediately when you quickly release the switch. It is also a variable speed switch that delivers higher speed and torque with increased trigger pressure. Speed is controlled by the amount of switch trigger precision.

⚠ WARNING!

Do not operate for long periods at low speed because excess heat will be produced internally.



2. FORWARD/REVERSE ROTATION CONTROL

The switch trigger (4) can be locked in the OFF position. This helps to reduce the possibility of accidental starting when not in use. To lock the switch trigger, place the rotation control in the center position.

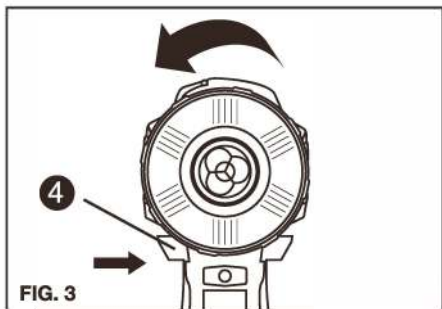

3. REVERSIBLE (SEE FIG. 3, FIG. 4)

For drilling and screw driving use forward rotation (4) marked "←" (lever is moved to the left). Only use reverse rotation marked "→" (lever is moved to the right) to remove screws or release a jammed drill bit.

⚠ WARNING!

Never change the direction of rotation when the chuck is rotating, wait until it has stopped.

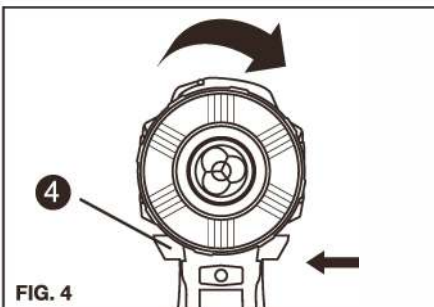

4. TWO-SPEED GEAR CONTROL (SEE FIG. 5)

The drill has a two-speed gear control (3) designed for drilling or driving at LOW (mark is 1) or HIGH (mark is 2) speeds. A slide switch is located on top of the drill to select either LOW or HIGH speed. When using the drill in the LOW speed range, the speed will decrease and the drill will have greater power and torque. When using the drill in the HIGH speed range, the speed will increase and the drill will have less power and torque.

Gear I

Low speed range: for screw driving or working with large drilling diameter

Gear II

High speed range: for working with small drilling diameter

⚠ WARNING!

To prevent gear damage, always allow the chuck to come to a complete stop before changing the direction of rotation or the two-speed gear control.



OPERATION

5. CHUCK ADJUSTMENT (SEE FIG. 6)

To open the chuck (1) jaws rotate the front section of the chuck. Insert the drill bit between the chuck jaws and rotate the front section in the opposite direction. Ensure the drill bit is in the center of the chuck jaws. Finally, firmly rotate the front chuck section in the opposite directions. Your drill bit is now clamped in the chuck.



FIG. 6

6. TORQUE ADJUSTMENT (SEE FIG. 7)

(Screw driving force of your drill driver)

The torque is adjusted by rotating the torque adjustment ring (2). The torque is greater when the torque adjustment ring is set on a higher setting. The torque is less when the torque adjustment ring is set on a lower setting. Make the setting as follows:



1 - 4	For driving small screws
5 - 9	For driving screws into soft material
10 - 14	For driving screws into soft and hard material
15 - 18	For driving screws into hard wood
	For heavy drilling
	For hammer drill



FIG. 7

7. USING THE LED LIGHT (SEE FIG. 8)

The LED light (9) allows you to keep a clear view under less illuminated circumstances. To turn on the light simply press the on/off switch. When you release the on/off switch, the light will go out.

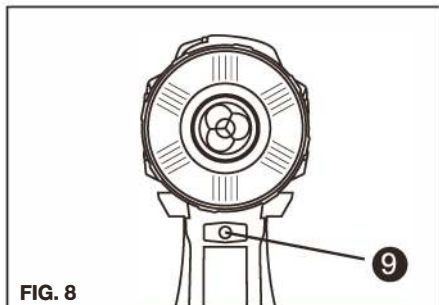

FIG. 8

8. DRILLING

When drilling into a hard smooth surface, use a center punch to mark the desired hole location. This will prevent the drill bit from slipping off center as the hole is started. Hold the tool firmly and place the tip of the bit at the point to be drilled. Depress the switch trigger to start the tool. Move the drill bit into the workpiece, applying only enough pressure to keep the bit rotating. Do not force or apply side pressure to elongate a hole.

A. Drilling In wood

Holes in wood can be made with the same twist drill bits used for metal or with spade bits. These bits should be sharp and should be pulled out frequently when drilling to clear chips from the flutes.

B. Drilling In Metal

Use a cutting lubricant when drilling metals. The exceptions are cast iron and brass which should be drilled dry. The cutting lubricants that work best are sulfured cutting oil or lard oil.

9. TOOL PROTECTION SYSTEM

The tool will automatically stop during operation if the tool and/or battery are placed under one of the following conditions:

- **Overloaded:** The tool is operated in a manner that causes it to draw an abnormally high current. In this situation, release the Trigger Switch on the tool and stop the application that caused the tool to become overloaded. Then pull the Trigger Switch again to restart.

OPERATION



- **Overheated:** Under the condition above, if the tool does not start, the Battery are overheated. In this situation, let the Tool and Battery cool before pulling the Trigger Switch again.
- **Low battery voltage:** The remaining Battery capacity is too low and the tool will not operate. In this situation, remove and recharge the Battery, drilled dry. The cutting lubricants that work best are sulfured cutting oil or lard oil.

PROBLEM SOLUTION

■ WHY DOES THE DRILL NOT TURN ON WHEN YOU PRESS THE SWITCH?

The forward/reverse rotation control, which is on top of the trigger, is positioned in the lock function. Unlock the forward/reverse rotation control by putting it into the required rotation position. Push the trigger and the drill will start to rotate. Or if the LED light flashes at the same time you press the Switch, please charge the battery.

■ THE DRILL STOPS BEFORE THE SCREW IS COMPLETELY TIGHTENED. WHY?

Verify the torque position of the torque adjusting ring, you can find the torque-adjusting ring between the chuck and the drill body. Position 1 is the lowest torque (screw driving force) and position 18 is the highest torque (screw driving force). Position  is for drill operation. Position  is for heavy drilling. Regulate the torque adjusting ring to a higher position to reach the best result.

■ REASONS FOR DIFFERENT BATTERY PACK WORKING TIMES

Charging time problems, as above, and having not used a battery pack for a prolonged time will reduce the battery pack working time. This can be corrected after several charge and discharge operations by charging & working with your drill. Heavy working conditions such as large screws into hard wood will use up the battery pack energy faster than lighter working conditions. Do not recharge your battery pack below 0°C and above 40°C as this will affect performance.

ENVIRONMENTAL PROTECTION



This product has been marked with a symbol relating to removing electric and electronic waste. This means that this product shall not be discarded with household waste but that it shall be returned to a collection system. It will then be recycled or dismantled in order to reduce the impact on the environment. Electric and electronic equipment can be hazardous for the environment and for human health since they contain hazardous substances.

DISPOSAL OF AN EXHAUSTED BATTERY PACK



To preserve natural resources, please recycle or dispose of the battery pack properly. This battery pack contains Li-ion batteries. Consult your local waste authority for information regarding available recycling and/or disposal options. Discharge your battery pack by operating your tool, then remove the battery pack from the tool housing and cover the battery pack connections with heavy-duty adhesive tape to

prevent short circuit and energy discharge. Do not attempt to open or remove any of the components.

PART LIST

Part No.	Description	Qty
1	M5*22 screw	1
2	Drilling chuck	1
3	Gear box assem.	1
4	M3*6 screw	2
5	Motor gear	1
6	550 motor	1
7	Double speed push button	1
8	Double speed push button spring	1
9	Double speed push button click spring	1
10	Click lever	1
11	Capacity show transparent cover	1
12	Trigger	1
13	Contact piece assem.	1
13-1	Contact shelf	1
13-2	Contact piece	2
14	Buckle	2
15	Battery pack	1
16	Gear shrapnel	1
17	LED transparent cover	1
18	Capacity show plate	1
19	Magnetic tube	1
20	Body housing	1
21	ST2.9*14 screw	8
22	Quick charger	1
23	Cord plug	1

PLEASE READ THE FOLLOWING CAREFULLY

THE MANUFACTURER AND/OR DISTRIBUTOR HAS PROVIDED THE PARTS LIST AND ASSEMBLY DIAGRAM IN THIS MANUAL AS A REFERENCE TOOL ONLY. NEITHER THE MANUFACTURER OR DISTRIBUTOR MAKES ANY REPRESENTATION OR WARRANTY OF ANY KIND TO THE BUYER THAT HE OR SHE IS QUALIFIED TO MAKE ANY REPAIRS TO THE PRODUCT, OR THAT HE OR SHE IS QUALIFIED TO REPLACE ANY PARTS OF THE PRODUCT. IN FACT, THE MANUFACTURER AND/OR DISTRIBUTOR EXPRESSLY STATES THAT ALL REPAIRS AND PARTS REPLACEMENTS SHOULD BE UNDERTAKEN BY CERTIFIED AND LICENSED TECHNICIANS, AND NOT BY THE BUYER. THE BUYER ASSUMES ALL RISK AND LIABILITY ARISING OUT OF HIS OR HER REPAIRS TO THE ORIGINAL PRODUCT OR REPLACEMENT PARTS THERETO, OR ARISING OUT OF HIS OR HER INSTALLATION OF REPLACEMENT PARTS THERETO.

Record Product's Serial Number Here: _____

Note: If product has no serial number, record month and year of purchase instead.

Note: Some parts are listed and shown for illustration purposes only and are not available individually as replacement parts.

The material in this manual is for informational purposes only. The product(s) it describes are subject to change without prior notice, due to the manufacturer's continuous development program. XtremePowerUS makes no representations or warranties with respect to this manual or with respect to the products described herein. XtremePowerUS shall not be liable for any damages, losses, costs or expenses, direct, indirect or incidental, consequential or special, arising out of, or related to the use of this material or the products described herein.

Questions, issues or missing parts?

Before returning to your retailer, our customer service team is here to help.



Call Us: 909.628.0880

Email Us: customer@xtremepowerusa.com

Hours of Operation: 9am - 3pm PST Monday - Friday

MADE IN CHINA