



Celestron **WEDGE**

for NexStar Evolution and NexStar SE 6 & 8

INSTRUCTION MANUAL

Model #93665

ENGLISH

Your NexStar tracks celestial objects with its altitude-azimuth motor drive. Objects will stay centered in the telescope's field of view, but with alt-az tracking they will rotate over time. This limits the potential exposure time when using the telescope for astrophotography. The Wedge tilts the telescope's azimuth axis so that it tracks stars as they move in an arc around the celestial pole. This keeps objects centered without rotation, allowing you to take longer exposure astrophotos.

Your wedge comes mostly assembled out of the box. However, you will need to attach the latitude adjustment rod and may need to adjust the side latitude plate depending on your location.

Part List

- Wedge Assembly
- Fork arm attachment bolt with washer
- 10mm hex key
- 8mm hex key
- 6mm hex key
- 5mm hex key
- 2.5mm hex key



Figure 1.1 Hardware



Figure 1.2 Wedge

Assembling the Wedge

1. Loosen the two latitude locking knobs on both sides of the wedge (Figure 2).
2. Push the tilt plate all the way forward as far as it will go, and hand tighten the latitude locking screws to hold the tilt plate in place.
3. Remove the two screws from each of the L-brackets on the bottom of the tilt plate.
4. Place one end of the swivel block into one of the top holes on the inside of the L-bracket.
5. Once one side of the swivel block is in place, reattach the screws to hold the L-bracket to the tilt plate.
6. Attach the remaining L-bracket to the bottom of the tilt plate making sure the other end of the swivel block fits inside the corresponding hole on the bracket. Tighten both brackets.

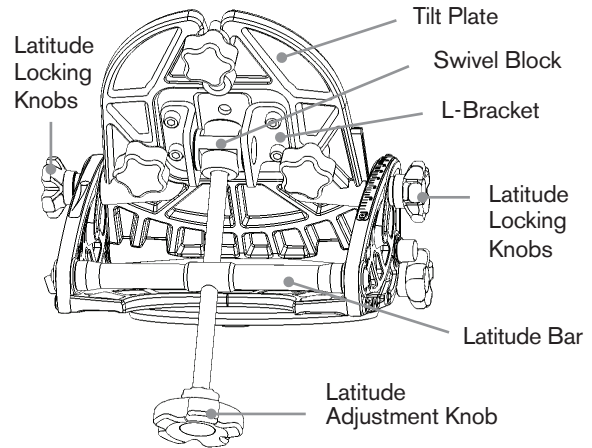

Figure 2

Adjusting the Center of Gravity of the Wedge

Before mounting a telescope to your wedge you may wish to change its center of gravity by shifting the wedge side plates forward. The side plates can be moved forward if you are observing from a higher latitude (50° or higher). This will place the telescope's center of gravity closer to the center of your tripod for maximum stability. To adjust the side plates:

1. Loosen the two latitude locking knobs on both sides of the wedge (Figure 2).
2. Push the tilt plate all the way forward as far as it will go, and hand tighten the latitude locking knobs to hold the tilt plate in place.
3. Slide the entire wedge forward so that the holes line up with the front three holes on the base plate. (Figure 3).
4. Replace the screws in the side plates in their new position.

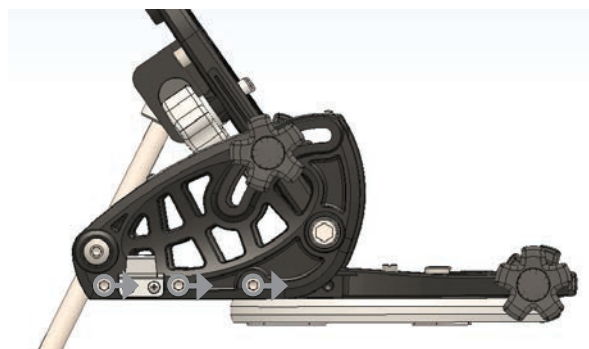

Figure 3

Attaching the Wedge to Your Tripod

The Wedge attaches to your Evolution or SE tripod using the tripod's 3 captive spring-loaded screws located under the tripod head. These are the 3 screws which normally attach to the fork arm assembly of your telescope.

1. Locate the positioning pin in the center of your tripod.
2. Lower the wedge onto the tripod so that the hole underneath the center of the base plate fits over the tripod positioning pin. This will allow you to center the wedge on the tripod head.
3. Rotate the wedge until the three registration pads on the wedge align with the three threaded holes on the tripod head.

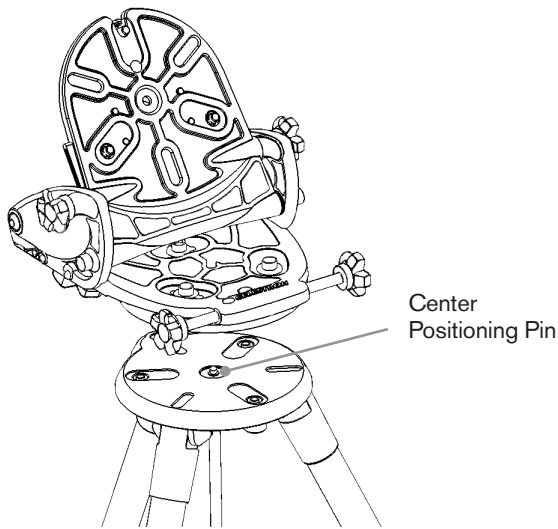

Figure 4.1

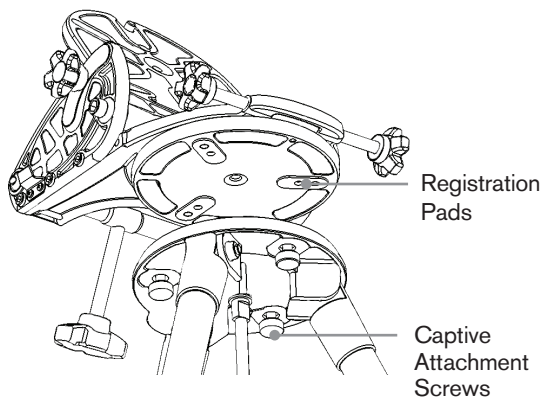

Figure 4.2

Latitude Adjustment

Before attaching your telescope to the wedge, you may wish to first adjust the wedge to the proper latitude. To do so:

1. Loosen the two latitude locking knobs (located on the side of the wedge) that secure the tilt plate. (See Figure 2).

2. Use the latitude adjustment knob to move the tilt plate until the latitude scale indicates the latitude of your location.
3. Tighten the latitude locking screws on the side of the wedge to secure the tilt plate in place.

Attaching the Telescope to the Wedge

1. Lay the telescope on its side and locate the three threaded holes in the bottom of the fork arm.
2. Thread the attachment bolt into the hole closest to the fork arm with a handle. Rotate the telescope base if necessary to align the fork arm with the closest hole.
3. Pick the telescope up by the fork arm and the base, and position it above the wedge.
4. Slide the bolt into the slotted hole at the top of the tilt plate.
5. Tighten the bolt slightly so that the bottom of the telescope base is flush to the tilt plate. Do not tighten it fully or you will not be able to move the base enough to insert the two remaining bolts.
6. Move the base of the telescope until the two remaining holes in the base line up with the holes in the tilt plate on the wedge. The raised feet on the bottom of the telescope base should drop into the recesses on the wedge tilt plate.
7. Thread the remaining two attachment bolts which are captive on the wedge.

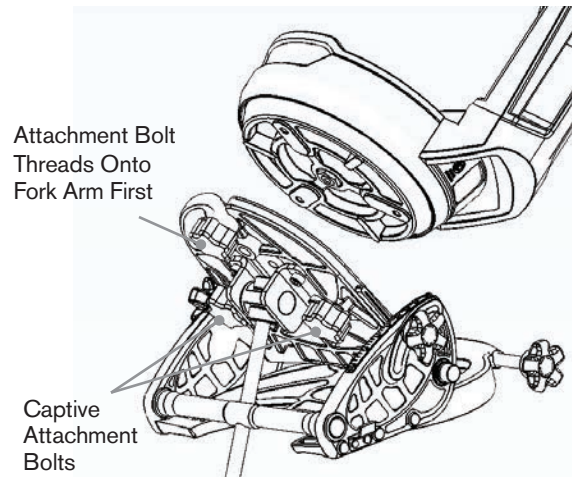

Figure 5

Polar Aligning The Wedge

Use the latitude adjustment knob to make final adjustments to your polar alignment in altitude. Use the azimuth adjustment knobs to make adjustments to your polar alignment in azimuth. In order to move your telescope smoothly in azimuth, slightly loosen the three azimuth plate screws before using the azimuth adjustment knobs (see Figure 6).

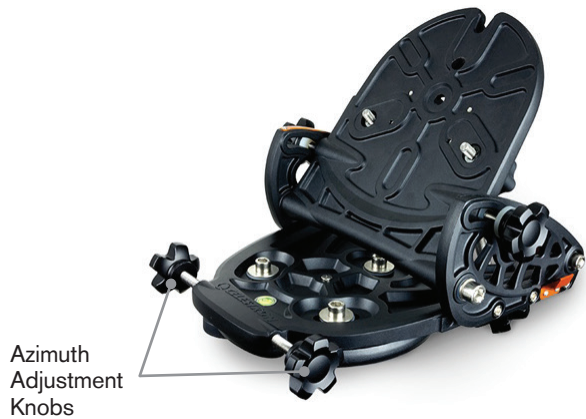

Figure 6

Tips for Use

If the latitude adjustment knob is difficult to turn, slightly loosen the bolts holding the orange latitude pivot bar. This will allow the bar to rotate more easily as the latitude angle changes.

Try to set your latitude and azimuth position on the wedge as close as possible before adding the weight of the telescope. This will minimize the amount of adjustment needed while the wedge is weighed down with the telescope.

For best stability, check that all socket head screws on the wedge are snug using the included hex keys. Polar align the wedge first, then check that everything is snug, but there is no need to overtighten.

SPECIFICATIONS	
Load capacity	16.3 KG (36 LBS)
Compatibility	NexStar Evolution 6, 8, 9.25, (works with CPC Tripod for 9.25 model), NexStar SE 6/8
Weight	6.8 kg (15 lbs)
Construction	Cast aluminum with machined aluminum parts
Latitude range	0° to 70°
Azimuth fine adjustment range	+/- 10°

CELESTRON TWO YEAR LIMITED WARRANTY

A. Celestron warrants your telescope mount to be free from defects in materials and workmanship for two years. Celestron will repair or replace such product or part thereof which, upon inspection by Celestron, is found to be defective in materials or workmanship.

As a condition to the obligation of Celestron to repair or replace such product, the product must be returned to Celestron together with proof-of-purchase satisfactory to Celestron.

B. The Proper Return Authorization Number must be obtained from Celestron in advance of return. Call Celestron at (310) 328-9560 to receive the number to be displayed on the outside of your shipping container.

All returns must be accompanied by a written statement setting forth the name, address, and daytime telephone number of the owner, together with a brief description of any claimed defects. Parts or product for which replacement is made shall become the property of Celestron.

The customer shall be responsible for all costs of transportation and insurance, both to and from the factory of Celestron, and shall be required to prepay such costs.

Celestron shall use reasonable efforts to repair or replace any telescope mount covered by this warranty within thirty days of receipt. In the event repair or replacement shall require more than thirty days, Celestron shall notify the customer accordingly. Celestron reserves the right to replace any product which has been discontinued from its product line with a new product of comparable value and function.

This warranty shall be void and of no force of effect in the event a covered product has been modified in design or function, or subjected to abuse, misuse, mishandling or unauthorized repair. Further, product malfunction or deterioration due to normal wear is not covered by this warranty.

CELESTRON DISCLAIMS ANY WARRANTIES, EXPRESS OR IMPLIED, WHETHER OF MERCHANTABILITY OF FITNESS FOR A PARTICULAR USE, EXCEPT AS EXPRESSLY SET FORTH HEREIN. THE SOLE OBLIGATION OF CELESTRON UNDER THIS LIMITED WARRANTY SHALL BE TO REPAIR OR REPLACE THE COVERED PRODUCT, IN ACCORDANCE WITH THE TERMS SET FORTH HEREIN. CELESTRON EXPRESSLY DISCLAIMS ANY LOST PROFITS, GENERAL, SPECIAL, INDIRECT OR CONSEQUENTIAL DAMAGES WHICH MAY RESULT FROM BREACH OF ANY WARRANTY, OR ARISING OUT OF THE USE OR INABILITY TO USE ANY CELESTRON PRODUCT. ANY WARRANTIES WHICH ARE IMPLIED AND WHICH CANNOT BE DISCLAIMED SHALL BE LIMITED IN DURATION TO A TERM OF TWO YEARS FROM THE DATE OF ORIGINAL RETAIL PURCHASE.

Some states do not allow the exclusion or limitation of incidental or consequential damages or limitation on how long an implied warranty lasts, so the above limitations and exclusions may not apply to you.

This warranty gives you specific legal rights, and you may also have other rights which vary from state to state.

Celestron reserves the right to modify or discontinue, without prior notice to you, any model or style telescope.

If warranty problems arise, or if you need assistance in using your telescope mount contact our customer service department.

NOTE: This warranty is valid to U.S.A. and Canadian customers who have purchased this product from an authorized Celestron dealer in the U.S.A. or Canada. Warranty outside the U.S.A. and Canada is valid only to customers who purchased from a Celestron's International Distributor or Authorized Celestron Dealer in the specific country. Please contact them for any warranty service.

www.celestron.com

2835 Columbia Street • Torrance, CA 90503 U.S.A.

Telephone: 800.421.9649

©2015 Celestron • All rights reserved.