



PRO

Installation Instructions & Owner's Manual

City Water Filter with Scale Control Media



For Models:
• FC1000

TABLE OF CONTENTS

Installation	3
Startup Instructions	5
Replacement Parts	6
Installation Fitting Assemblies	7
Warranty	9
Quick Reference Guide	11

PRODUCT INFORMATION

MODEL NUMBER _____

SERIAL NUMBER _____

DEALER INFORMATION:

Your A. O. Smith Pro Series water filter is a precision built, high quality product. These units will deliver filtered water for many years to come when installed and operated properly. Please study this manual carefully and understand the cautions and notes before installing. This manual should be kept for future reference. If you have any questions regarding your water filter, contact your local dealer.

INSTALLATION

GENERAL INSTALLATION & SERVICE WARNINGS

The control valve, fittings and/or bypass are designed to accommodate minor plumbing misalignments. There is a small amount of “give” to properly connect the piping, but the water treatment unit is not designed to support the weight of the plumbing.

Do not use Vaseline, oils, other hydrocarbon lubricants, or spray silicone anywhere. A silicone lubricant may be used on black “O” Rings, but is not necessary. **Avoid any type of lubricants, including silicone, on red or clear lip seals.**

Do not use pipe dope or other sealants on threads. Teflon® tape must be used on the threads of the 1” NPT inlet and outlet and on the threads for the drain line connection. Teflon® tape is not used on the nut connections or caps because “O” Ring seals are used. The nuts and caps are designed to be unscrewed or tightened by hand or with the special plastic Service Wrench, #100249864 (CV3193-02). If necessary, pliers can be used to unscrew the nut or cap. Do not use a pipe wrench to tighten nuts or caps. **Do not place screwdriver in slots on caps and/or tap with a hammer.**

SITE REQUIREMENTS

- One Water Conditioner to Filter
- Water Pressure – 25-100 psi
- Water Temperature – 40-100°F (0.5-37.7°C)

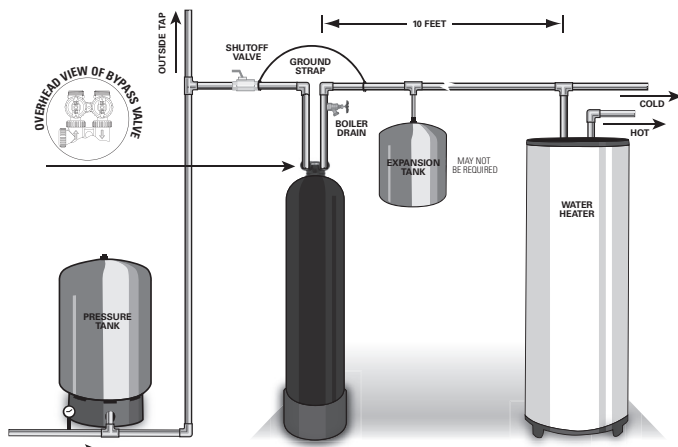

WELL WATER INSTALLATION

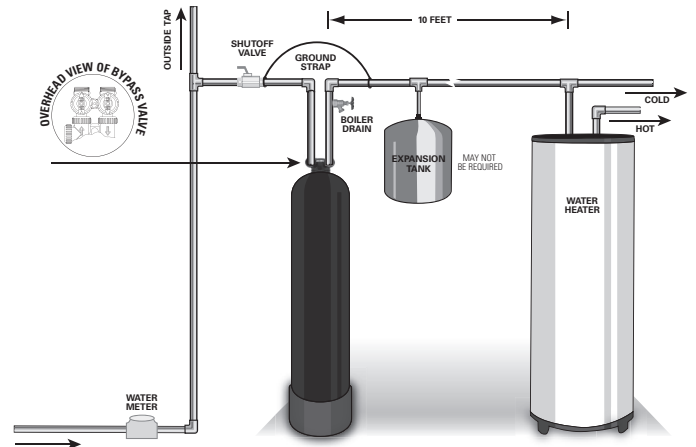

MUNICIPAL INSTALLATION

1. The distance between the drain and the water conditioner should be as short as possible (see #8).
2. The media tank should be installed on a firm, level surface (above or below grade).
3. It is NOT recommended to install any water treatment unit with less than 10 feet of piping between its outlet and the inlet of a water heater.



CAUTION: To protect the unit in the event of a hot water heater backup, the manufacturer recommends the use of an expansion tank on the outlet side of the unit (see diagram).

4. Do not locate unit where it or its connections (including the drain and overflow lines) will ever be subjected to temperatures under 33°F.
5. Do not subject the tank to any vacuum as this may cause an “implosion” and could result in leaking. If there is a possibility a vacuum could occur, please make provision for a vacuum breaker in the installation.
6. **INLET/OUTLET PLUMBING:** Be sure to install Bypass Valve onto main control valve before beginning plumbing. If it is desired to bypass outside hydrants, a cold water kitchen sink, or other locations, provisions should be made at this time. Install an inlet shutoff valve and plumb to the unit’s bypass valve inlet located at the right rear as you face the unit. There are a variety of installation fittings available. They are listed under the Installation Fitting Assemblies section of the manual. When assembling the installation fitting package (inlet and outlet), connect the fitting to the plumbing system first and then attach the nut, split ring and “O” Ring. Heat from soldering or solvent cements may damage the nut, split ring or “O” Ring. Solder joints should be cool and solvent cements should be set before installing the nut, split ring and “O” Ring. Avoid getting solder flux, primer, and solvent cement on any part of the “O” Rings, split rings, bypass valve or control valve. If the building’s electrical system is grounded to the plumbing, install a copper grounding strap from the inlet to the outlet pipe. Plumbing must be done in accordance with all applicable local codes.

INSTALLATION

Provisions should be made to bypass outside hydrants that are not to have filtered water. It is also advisable to install hose bibs on the inlet and outside of the filter for future testing and service of the equipment. Where heavy sediment from the well is observed, it is advisable to install a cartridge or bag-style filter immediately upstream from the filter. A nominal micron rating of 50 to 100 is recommended. The purpose of this is to protect the control valve of any debris from the incoming water supply. If desired, a cartridge filter may be used after the system as a polishing filter.

7. **INSTALLING GROUND:** To maintain an electrical ground in metal plumbing of a home's cold water piping (such as a copper plumbing system), install a ground clamp or jumper wiring.

NOTE: If replacing an existing unit, also replace the ground clamps/wire. If removing a unit, replace the piping with the same type of piping as the original to assure plumbing integrity and grounding.

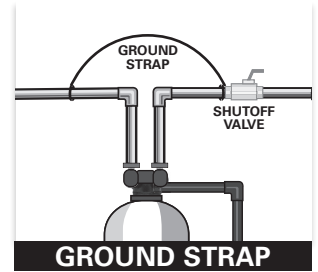

STARTUP INSTRUCTIONS

OPERATION

The FC-1000 City Water Filter requires no backwashing and eliminates the need for a control valve and the extra water needed to regenerate. The unit is equipped with an upper strainer assembly to prevent mineral loss. Please contact A. O. Smith with any questions pertaining to the FC-1000 installation.

OPERATING LIMITS

The unit is designed to function with minimum water pressures of 20 psi, maximum water pressures of 100 psi, and a maximum water temperature of 100 degrees F.

WATER QUALITY CONDITIONS

For the carbon and scale control media to be effective, incoming water must be clear, sediment free, with iron less than 0.3 ppm, pH less than 8.3, and hardness below 15gpg.

IN AND OUT VALVE

- CAUTION: Ensure the In and Out Valve is tight on top of the tank. DO NOT overtighten.**
- Locate the bypass valve assembly that is packaged with the system. The bypass valve has two red handles that allow you to bypass the unit, two threaded connections for the tail piece kit and two O-ring seal connections with nuts for the In and Out Valve. Align the insert connection ends with O-rings and nuts to the inlet and outlet connections of the control valve. Hand tighten the nuts.
- Locate and assemble the tail piece kit. Align tail piece assembly to the bypass valve threaded inlet and insert until the nut can be tightened. Hand tighten the nuts.

SERVICE LINE PIPING

- Keep unit far enough away from walls and other obstructions to allow for servicing the unit. Pipe water filter into the service lines. Plumb the inlet plumbing into the UPFLOW INLET port of the in-out valve. Plumb the outlet plumbing into the DOWNFLOW INLET port of the in-out valve. Plumbing the unit for UPFLOW configuration will prevent channeling of the media bed. Always follow local plumbing codes when installing our water treatment equipment.
- If sweat fittings are used, be sure soldering is done in such a manner as not to allow heat to reach the control valve or bypass. If using copper pipe, make all sweat connections away from the tank, strainer, and head assemblies or the heat will damage them and void warranty. Use unions on the inlet and outlet connections.
- Pipe a boiler drain into the inlet and outlet piping as shown in the Drawing to the right.

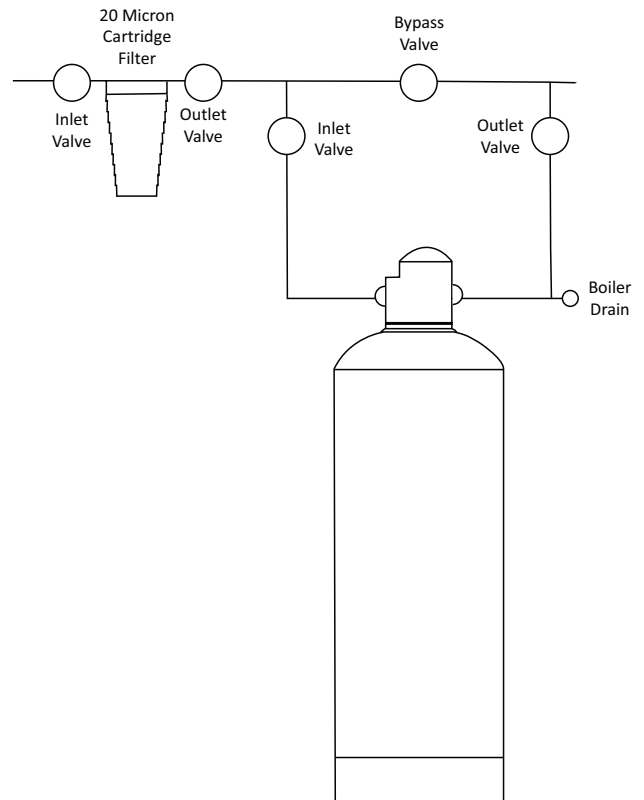

FILLING FILTER WITH WATER

- Direct water from the outlet boiler drain to a floor drain and flush the plumbing to ensure no glue, tape or shavings enter the unit. With the bypass closed, open the outlet boiler drain and run water through the newly installed plumbing to drain.
- Fully open the outlet bypass and SLIGHTLY crack open the inlet bypass. Air will slowly be pushed out of the tank and out the drain. Once water is running out the drain, you can close the inlet bypass and allow the media to soak for 30 minutes with the bypass and boiler drain closed. Once soaked, open the boiler drain, and both the outlet and inlet bypass handles to direct water from the system to drain. Run water until the water becomes clear and free of air pockets. When clear, close outlet boiler drain.
- The unit is now in the service position.
- If you choose not to pipe in boiler drains, then you should rinse the system by running water at an outside spigot or nearby sink until the water is clear and has no fines or color. You should thoroughly rinse the system of its fines and color before placing the unit into service position.

CARBON/MEDIA LOADING

- Remove the In and Out valve assembly from the top of the tank and make sure the riser tube is secured to the vortech plate. The distributor is permanently attached to the vortech plate so centering is not necessary. The top of the distributor will be 5/8" above the top of the tank.
- Cover the top opening of the distributor pipe before filling the tank with media.
- Pour the coconut carbon provided with the unit into the top of the tank. Then pour the scale control media on top of the carbon.
- Remove the material used to cover the top of the distributor pipe and clean the tank threads of any media. Reattach the in and out valve assembly.

REPLACEMENT PARTS

BYPASS VALVE				
Item #.	Legacy Part #	Current Part #	Description	Qty.
1	CV3006	100249845	Bypass assembly	1
2	CV3147	100246284	Bypass handles	2

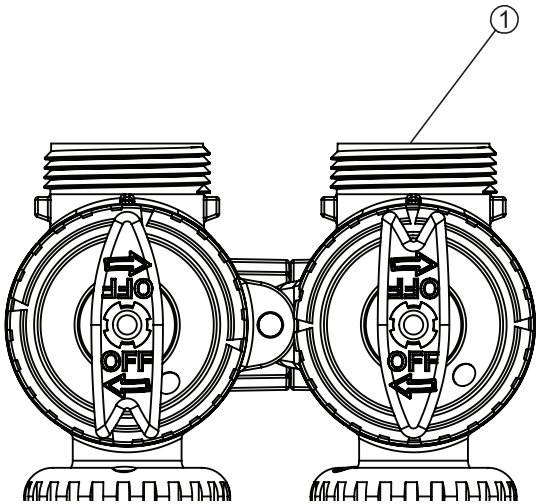

IN/OUT HEAD				
Item #	Legacy Part #	Current Part #	Description	Qty.
	CD1400	100245769	1191 In/Out Head	1
Not Shown	CV3180	100246307	Base O-Ring	1
	CV3105	100246272	Distributor Pilot O-Ring 215	1

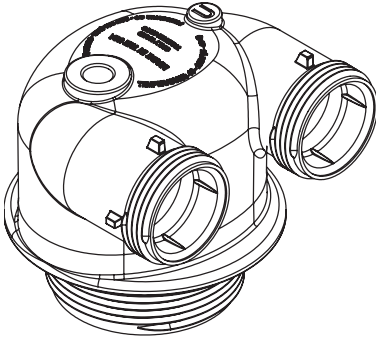

INSTALLATION FITTING ASSEMBLIES

NOTE: Not all available fittings are displayed below. Contact manufacturer for optional fittings.

For All Assemblies

Item #	Legacy Part #	Current Part #	Description	Qty.
1	CV3151	100246287	Nut, 1" quick connect	2
2	CV3150	100246286	Split ring	2
3	CV3105	100246272	O-ring 215	2

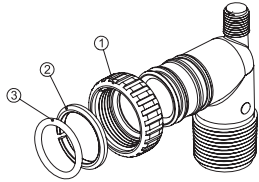

Legacy Part #	Current Part #	Description	Qty.
CV3007	100246197	1" PVC male NPT elbow assembly	2

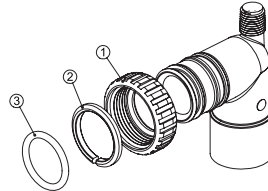

Legacy Part #	Current Part #	Description	Qty.
CV3007-01	100246198	3/4" & 1" PVC solvent elbow assembly	2

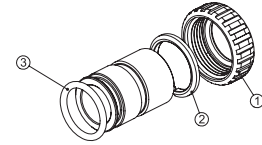

Legacy Part #	Current Part #	Description	Qty.
CV3007-02	100246199	1" brass sweat assembly	2

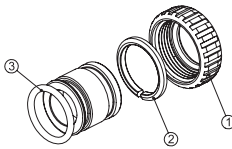

Legacy Part #	Current Part #	Description	Qty.
CV3007-03	100249846	3/4" brass sweat assembly	2

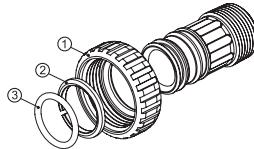

Legacy Part #	Current Part #	Description	Qty.
CV3007-04	100244506	1" plastic male NPT assembly	2

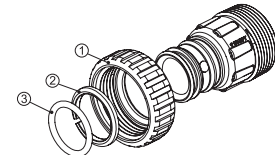

Legacy Part #	Current Part #	Description	Qty.
CV3007-05	100243921	1-1/4" plastic male assembly	2

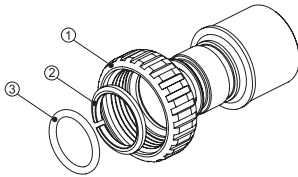

Legacy Part #	Current Part #	Description	Qty.
CV3007-09	100243922	1-1/4" & 1-1/2" brass sweat assembly	2

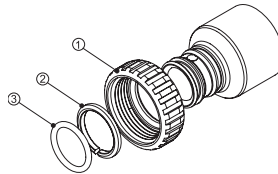

Legacy Part #	Current Part #	Description	Qty.
CV3007-07	100243375	1-1/4" & 1-1/2" PVC solvent assembly	2

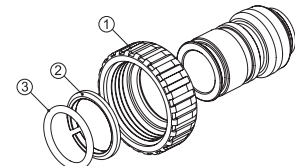

Legacy Part #	Current Part #	Description	Qty.
CV3007-12	100249847	3/4" brass shark bite assembly	2

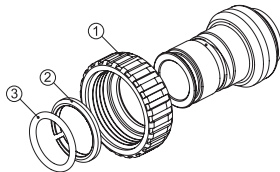

Legacy Part #	Current Part #	Description	Qty.
CV3007-13	100249848	1" brass shark bite assembly	2

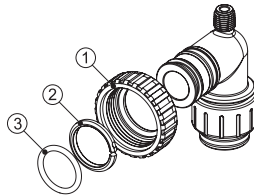

Legacy Part #	Current Part #	Description	Qty.
CV3007-15	100246200	3/4" john guest elbow assembly	2

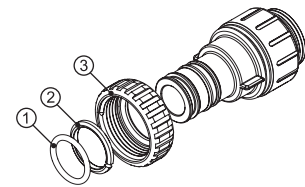

Legacy Part #	Current Part #	Description	Qty.
CV3007-17	100245045	1" john guest assembly	2

This page intentionally left blank.



PRO

Water Filter Limited Warranty

Congratulations. You have purchased one of the finest water treatment systems available. In the unlikely event of a problem due to defects in material and workmanship, we proudly warrant our water filters to the original owner, when installed in accordance with A. O. Smith® specifications. This warranty is effective from the date of original installation for:

A period of TEN YEARS: **Fiberglass mineral tanks 13” and smaller; except for damages due to freezing, high pressure (120 PSI and above), extreme temperature (100°F and above) or a vacuum on the system.**

A period of FIVE YEARS: **Valve Body and PC Board.
Fiberglass mineral tanks 14” and larger.**

A period of ONE YEAR: **All other filter components.**

Any part found defective within the terms of this warranty will be repaired or replaced by the dealer. You pay only freight from our factory and local dealer charges. To obtain local warranty service, contact original dealer or an authorized service dealer. If no authorized dealer is located in your area, please ship defective part or component freight prepaid to A. O. Smith, 1900 Prospect Ct., Appleton, Wisconsin 54914. A. O. Smith, at its discretion, will repair or replace the part or component at its expense and return part freight collect.

The above provisions of the warranty are valid as long as the unit is connected in compliance with local plumbing codes and in an equivalent manner and condition of the original installation and is owned by the original owner.

This warranty does not cover damages due to accident, fire, flood, freezing, or any other Act of God. We are not responsible for damages due to change in water conditions, misapplication, misuse, neglect, vacuum, oxidizing agents, alteration, or lack of maintenance. No responsibility is assumed for loss of use of the unit, inconvenience, loss or damage to real or personal property or any incidental or consequential damages. Furthermore, we assume no liability and extend no warranties, express or implied, for the use of this product with a non-potable water source. **To the extent permitted by law, A. O. Smith disclaims all implied warranties, including without limitation warranties of merchantability and fitness for particular purpose; to the extent required by law, any such implied warranties are limited in duration to the aforementioned period specified above.**

Some states do not allow the exclusion of implied warranties or limitations on how long an implied warranty lasts. Consequently, the above limitation may not apply to you.

This warranty gives you specific legal rights, and you may also have other rights which vary from state to state.

This page intentionally left blank.

BYPASS VALVE OPERATION

To shut off water to the system, position arrow handles as shown in the bypass operation diagram below. If your valve doesn't look like the diagram below, contact your service technician for instructions on how to shut off water.

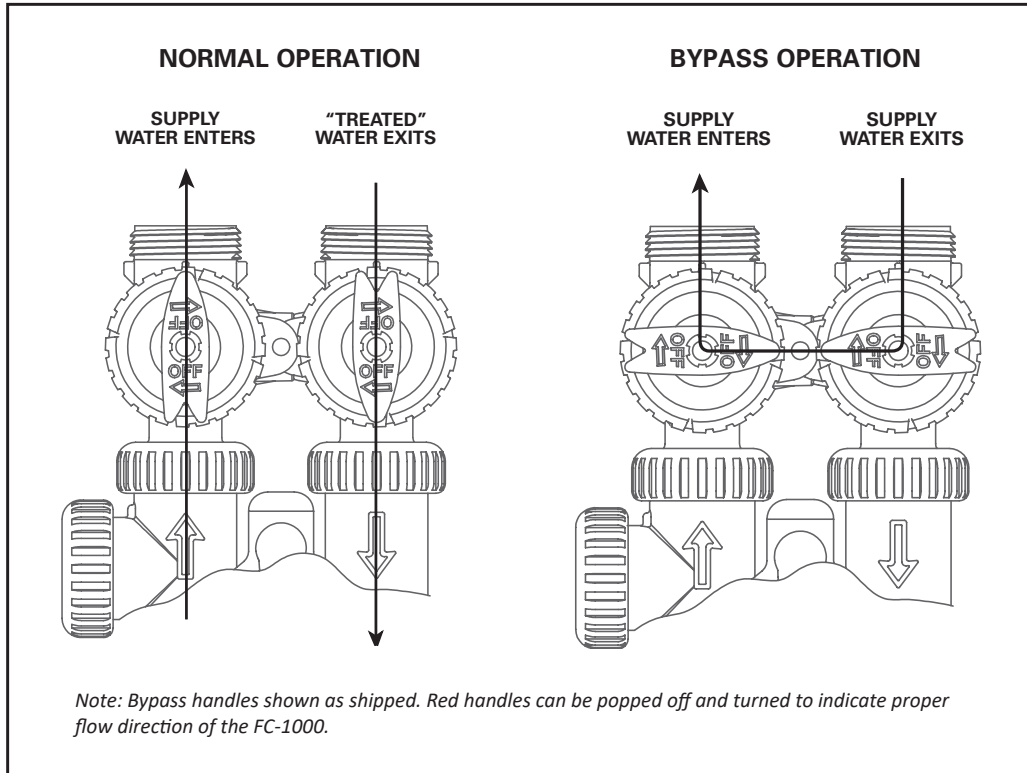



PRO

1900 Prospect Court, Appleton, WI, 54914
aosmith.com/watertreatment

