

NordicTrack® COMMERCIAL VR 21

Model No. NTEVEX76017.0

Serial No. _____

Write the serial number in the space above for reference.

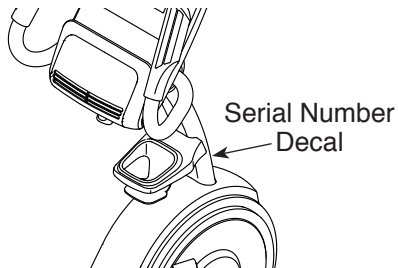

USER'S MANUAL

CUSTOMER SERVICE

UNITED KINGDOM

Call: 0330 123 1045

From Ireland: 053 92 36102

Website: iconsupport.eu

E-mail: csuk@iconeurope.com

Write:

ICON Health & Fitness, Ltd.

Unit 4, Westgate Court

Silkwood Park

OSSETT

WF5 9TT

UNITED KINGDOM

AUSTRALIA

Call: 1800 993 770

E-mail: australiacc@iconfitness.com

Write:

ICON Health & Fitness

PO Box 635

WINSTON HILLS NSW 2153

AUSTRALIA

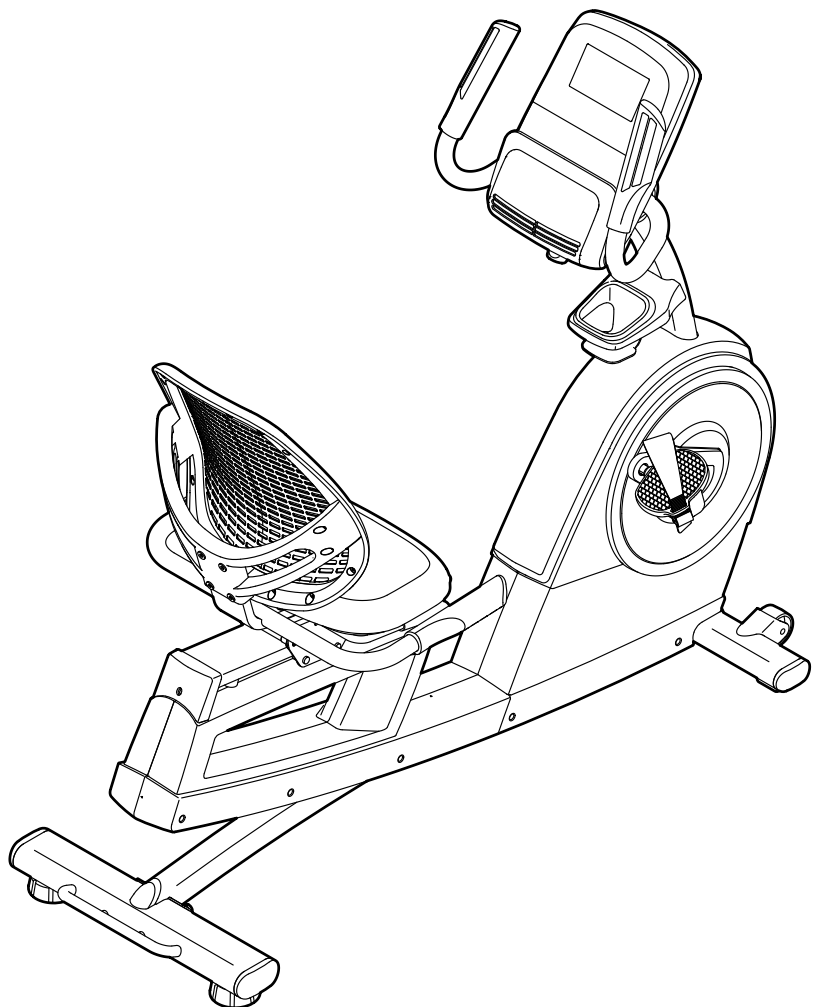

⚠ CAUTION

Read all precautions and instructions in this manual before using this equipment. Keep this manual for future reference.

iconeurope.com

TABLE OF CONTENTS

WARNING DECAL PLACEMENT 2

IMPORTANT PRECAUTIONS..... 3

BEFORE YOU BEGIN..... 4

PART IDENTIFICATION CHART..... 5

ASSEMBLY..... 6

HOW TO USE THE EXERCISE BIKE..... 13

MAINTENANCE AND TROUBLESHOOTING 21

EXERCISE GUIDELINES 23

PART LIST..... 24

EXPLODED DRAWING..... 26

ORDERING REPLACEMENT PARTS Back Cover

RECYCLING INFORMATION Back Cover

WARNING DECAL PLACEMENT

This drawing shows the location(s) of the warning decal(s). If a decal is missing or illegible, see the front cover of this manual and request a free replacement decal. Apply the decal in the location shown. Note: The decal(s) may not be shown at actual size.

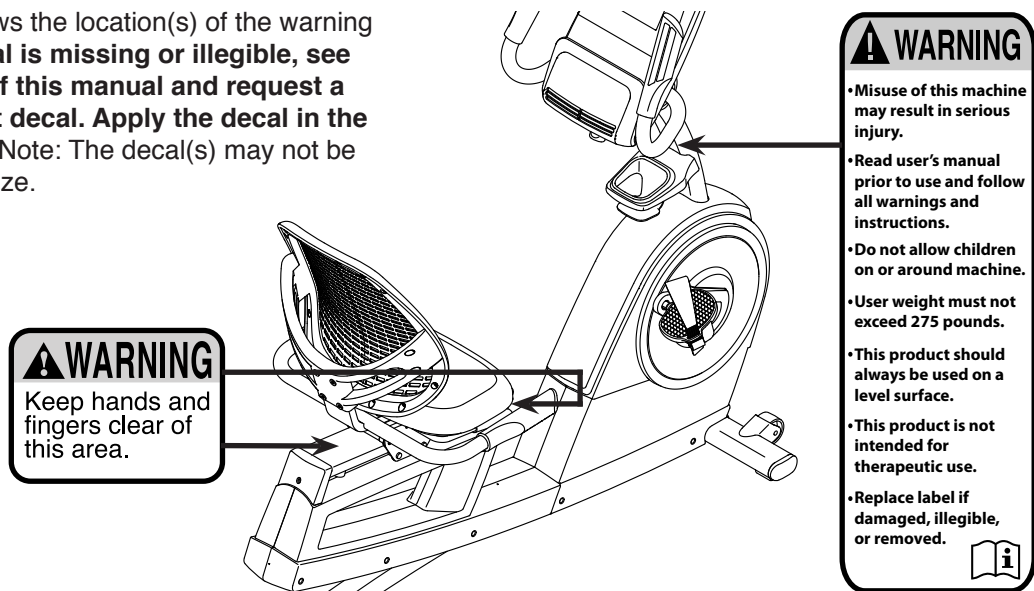

NORDICTRACK and IFIT are registered trademarks of ICON Health & Fitness, Inc. App Store is a trademark of Apple Inc., registered in the U.S. and other countries. Android and Google Play are trademarks of Google Inc. The BLUETOOTH® word mark and logos are registered trademarks of Bluetooth SIG, Inc. and are used under license. IOS is a trademark or registered trademark of Cisco in the U.S. and other countries and is used under license.

IMPORTANT PRECAUTIONS

⚠ WARNING: To reduce the risk of serious injury, read all important precautions and instructions in this manual and all warnings on your exercise bike before using your exercise bike. ICON assumes no responsibility for personal injury or property damage sustained by or through the use of this product.

1. It is the responsibility of the owner to ensure that all users of the exercise bike are adequately informed of all precautions.
2. Before beginning any exercise program, consult your physician. This is especially important for persons over age 35 or persons with pre-existing health problems.
3. The exercise bike is not intended for use by persons with reduced physical, sensory, or mental capabilities or lack of experience and knowledge, unless they are given supervision or instruction about use of the exercise bike by someone responsible for their safety.
4. Use the exercise bike only as described in this manual.
5. The exercise bike is intended for home use only. Do not use the exercise bike in a commercial, rental, or institutional setting.
6. Keep the exercise bike indoors, away from moisture and dust. Do not put the exercise bike in a garage or covered patio, or near water.
7. Place the exercise bike on a level surface, with a mat beneath it to protect the floor or carpet. Make sure that there is at least 2 ft. (0.6 m) of clearance around the exercise bike.
8. Inspect and properly tighten all parts each time the exercise bike is used. Replace any worn parts immediately.
9. Keep children under age 13 and pets away from the exercise bike at all times.
10. Wear appropriate clothes while exercising; do not wear loose clothes that could become caught on the exercise bike. Always wear athletic shoes for foot protection.
11. The exercise bike should not be used by persons weighing more than 275 lbs. (125 kg).
12. Be careful when mounting and dismounting the exercise bike.
13. Always keep your back straight while using the exercise bike; do not arch your back.
14. The heart rate monitor is not a medical device. Various factors may affect the accuracy of heart rate readings. The heart rate monitor is intended only as an exercise aid in determining heart rate trends in general.
15. Over exercising may result in serious injury or death. If you feel faint, if you become short of breath, or if you experience pain while exercising, stop immediately and cool down.

BEFORE YOU BEGIN

Thank you for selecting the new NORDICTRACK® COMMERCIAL VR 21 exercise bike. Cycling is an effective exercise for increasing cardiovascular fitness, building endurance, and toning the body. The COMMERCIAL VR 21 exercise bike provides a selection of features designed to make your workouts at home more effective and enjoyable.

For your benefit, read this manual carefully before you use the exercise bike. If you have questions after

reading this manual, please see the front cover of this manual. To help us assist you, note the product model number and serial number before contacting us. The model number and the location of the serial number decal are shown on the front cover of this manual.

Before reading further, please familiarize yourself with the parts that are labeled in the drawing below.

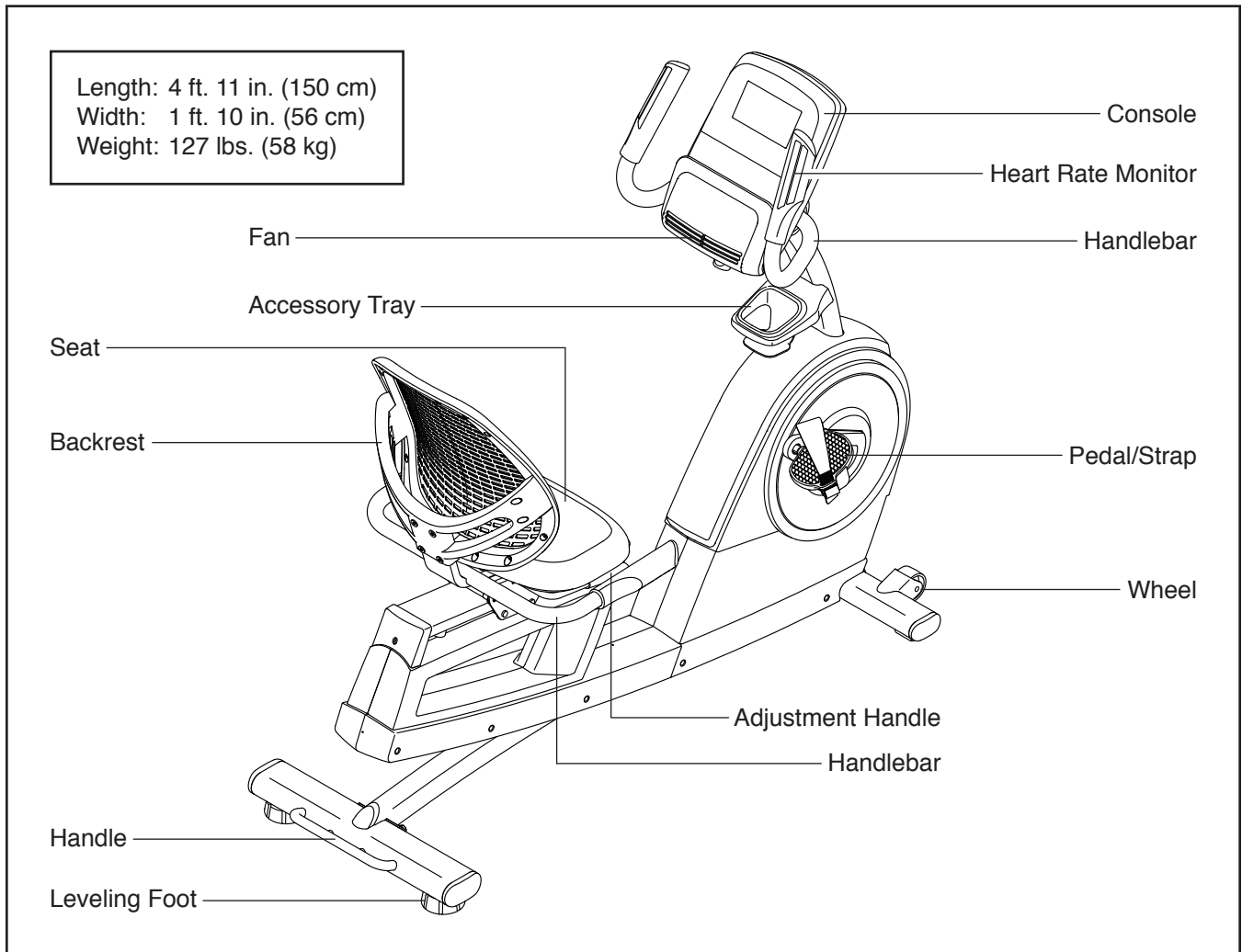

PART IDENTIFICATION CHART

Use the drawings below to identify the small parts needed for assembly. The number in parentheses below each drawing is the key number of the part, from the PART LIST near the end of this manual. The number following the key number is the quantity needed for assembly. **Note: If a part is not in the hardware kit, check to see if it has been preassembled. Extra parts may be included.**

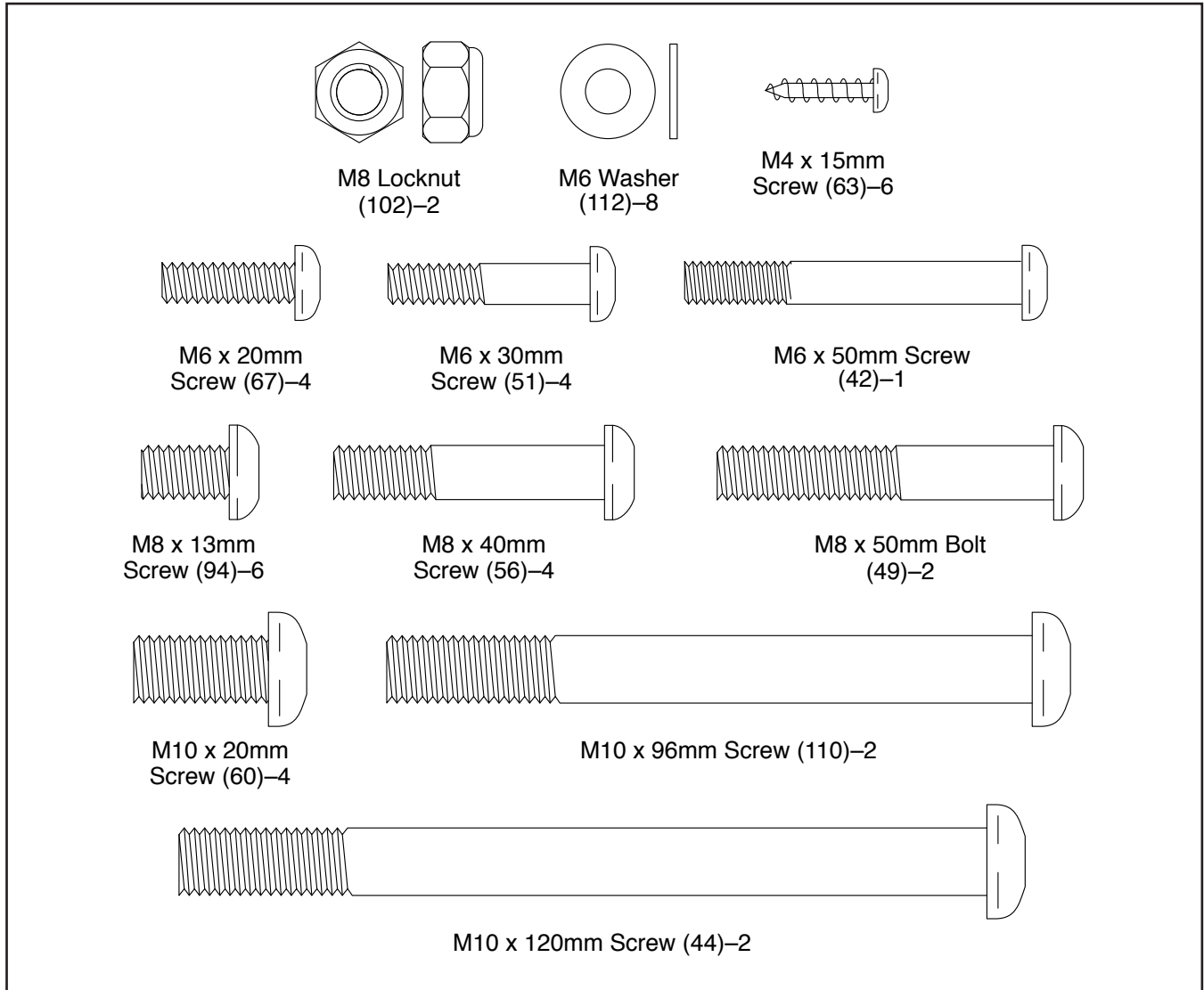

ASSEMBLY

- Assembly requires two persons.
- Place all parts in a cleared area and remove the packing materials. Do not dispose of the packing materials until you finish all assembly steps.
- Left parts are marked “L” or “Left” and right parts are marked “R” or “Right.”
- To identify small parts, see page 5.

In addition to the included tool(s), assembly requires the following tools:

one Phillips screwdriver 

one adjustable wrench 

Assembly may be easier if you have a set of wrenches. To avoid damaging parts, do not use power tools.

1. **To register your product and activate your warranty in the UK**, go to iconsupport.eu. If you do not have internet access, call Customer Service (see the front cover of this manual).

To register your product and activate your warranty in Australia, email or post the following information to the email address or postal address on the front cover of this manual.

- your receipt (make sure to keep a copy)
- your name, address, and telephone number
- the model number, serial number, and name of your product (see the front cover of this manual)

2. If there are shipping bracket(s) on the front and rear of the Frame (1), remove and discard the shipping bracket(s) and the hardware attaching them.

With the help of a second person, place some of the packing materials (not shown) under the front of the Frame (1).

Attach the Front Stabilizer (2) to the Frame (1) with two M10 x 96mm Screws (110); **start both Screws, and then tighten them.**

Then, remove the packing material from under the Frame (1).

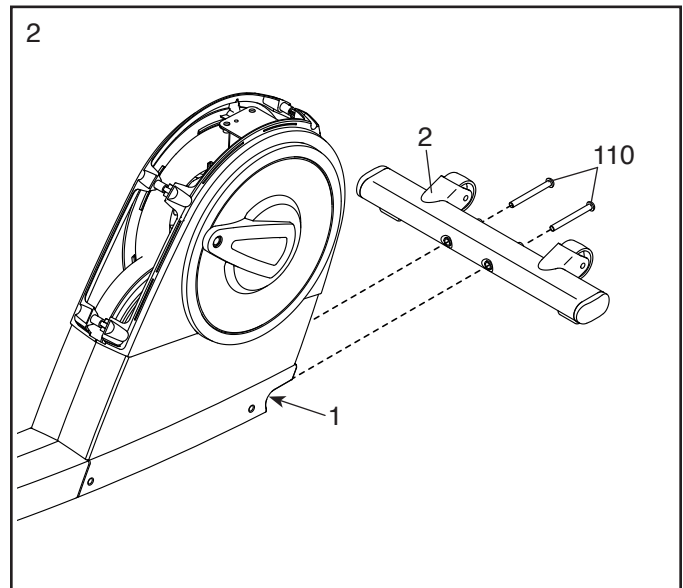
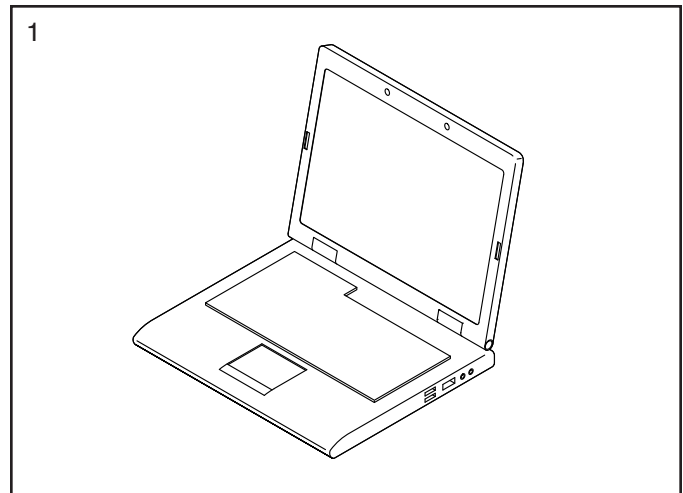

3. With the help of a second person, place some of the packing materials (not shown) under the rear of the Frame (1).

Attach the Rear Stabilizer (3) to the Frame (1) with two M10 x 120mm Screws (44); **start both Screws, and then tighten them.**

Then, remove the packing material from under the Frame (1).

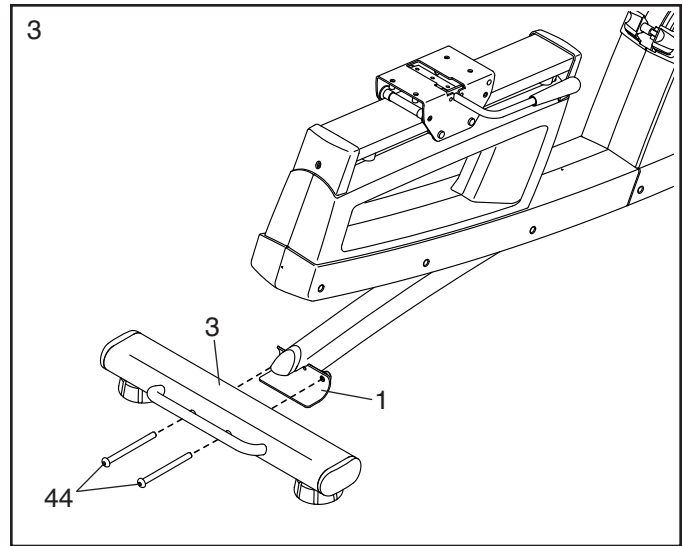

4. Have a second person hold the Upright (4) on the Frame (1).

Tip: Avoid pinching the Main Wire (41). Attach the Upright (4) with four M10 x 20mm Screws (60); **start all the Screws, and then tighten them.**

Next, locate the wire tie (A) inside the Upright (4). Tie the lower end of the wire tie to the Main Wire (41). Then, pull the other end of the wire tie upward until the Main Wire is routed through the Upright.

Tip: To prevent the Main Wire (41) from falling into the Upright (4), secure it to the Upright with the wire tie (A).

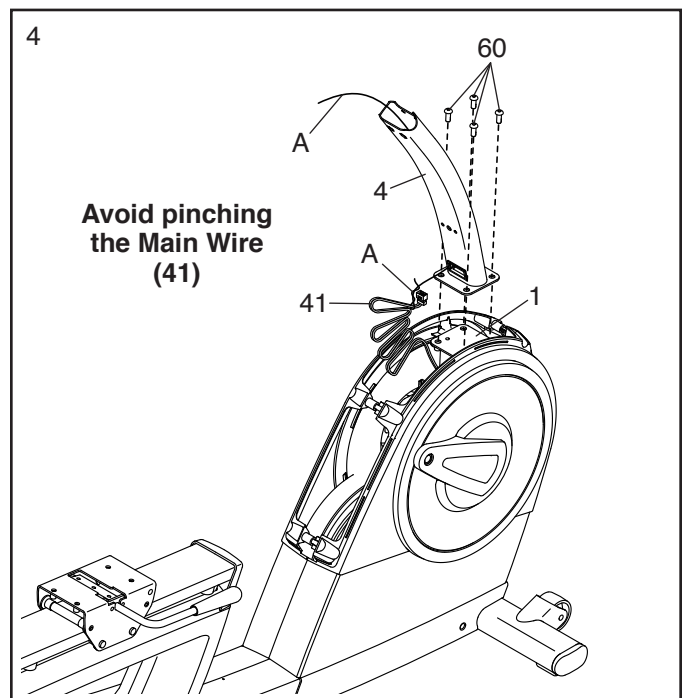

5. Slide the Upright Cover (19) onto the Upright (4) and press it onto the Left and Right Shields (21, 22).

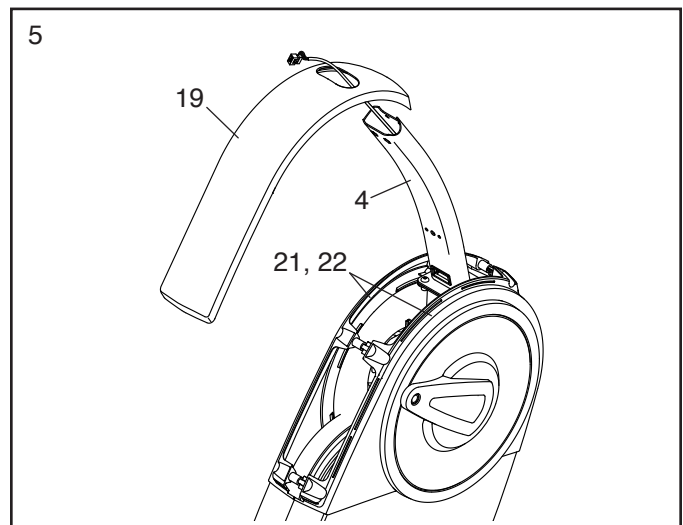

6. Attach the Accessory Tray (9) to the Upright (4) with an M6 x 50mm Screw (42).

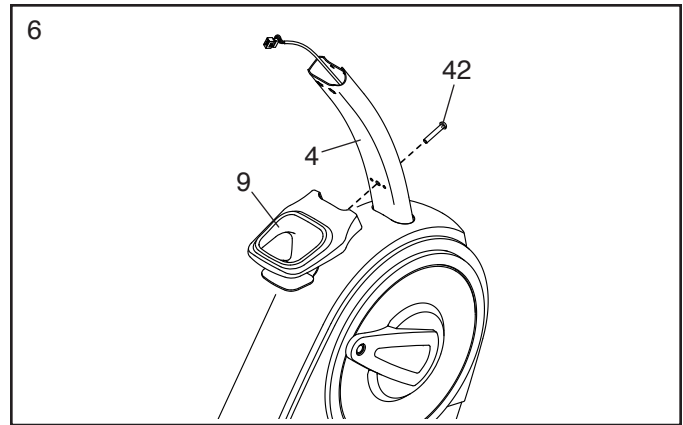

7. Untie and discard the wire tie on the Main Wire (41).

While a second person holds the Console Bracket (82) near the Upright (4), route the Main Wire (41) through the notch in the Upright, through the Upright Bracket (84), and through the hole in the center of the Console Bracket.

Tip: Avoid pinching the Main Wire (41). Insert the Upright Bracket (84) into the Upright (4).

Attach the Upright Bracket (84) with two M8 x 50mm Bolts (49) and two M8 Locknuts (102); **start both Bolts, and then tighten them. Make sure that the Locknuts are in the hexagonal holes (B).**

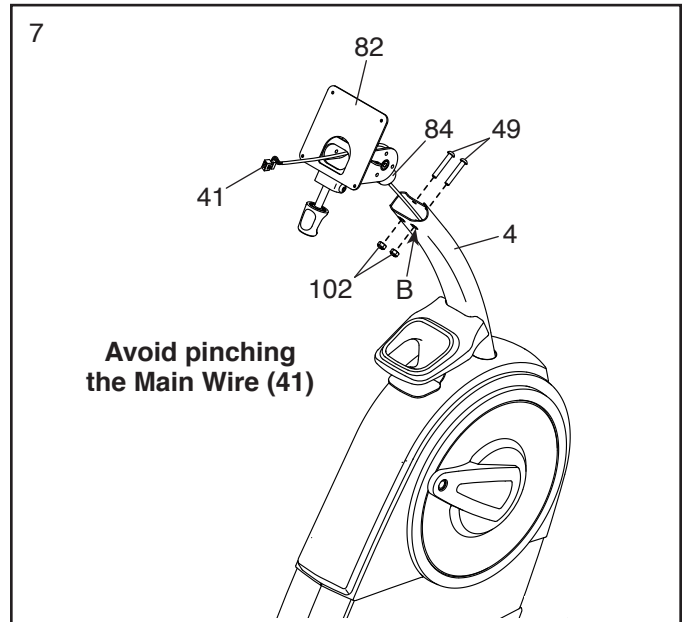

8. Identify the Right Handlebar (81) and orient it as shown.

Tip: Avoid pinching the Right Pulse Wire (8). Attach the Right Handlebar (81) to the right side of the Console Bracket (82) with three M8 x 13mm Screws (94); **start all the Screws, and then tighten them.**

Then, route the Right Pulse Wire (8) in the Right Handlebar (81) through the Console Bracket (82) as shown.

Repeat this step to attach the Left Handlebar (6).

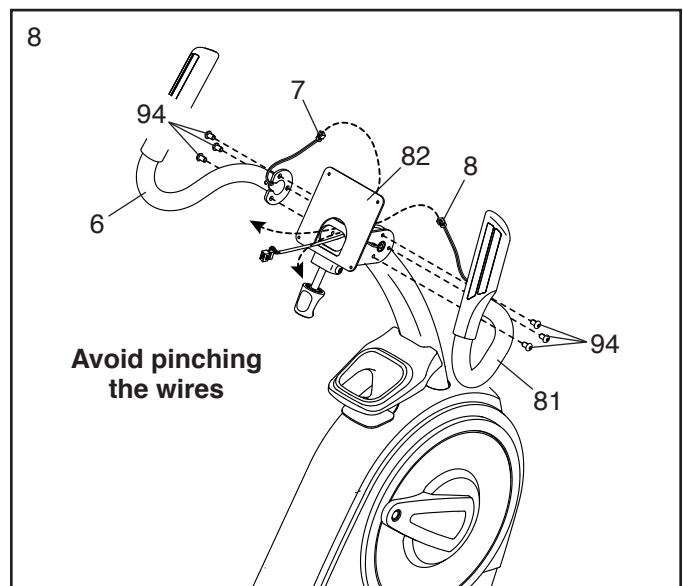

9. While a second person holds the Console (5) near the Console Bracket (82), connect the wires on the Console to the Main Wire (41) and to the Left and Right Pulse Wires (7, 8).

Insert the excess wire into the Console Bracket (82).

Tip: Avoid pinching the wires. Attach the Console (5) to the Console Bracket (82) with four M4 x 15mm Screws (63); **start all the Screws, and then tighten them.**

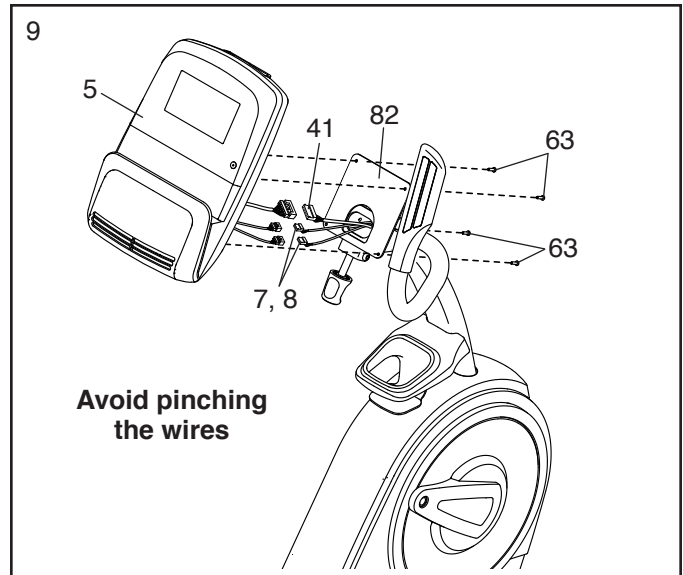

10. Identify the Upper and Lower Bracket Covers (20, 80), orient them as shown, and press them together around the Console Bracket (82).

Tip: Avoid pinching the Left and Right Pulse Wires (7, 8). Attach the Upper and Lower Bracket Covers (20, 80) to the Console Bracket (82) with two M4 x 15mm Screws (63).

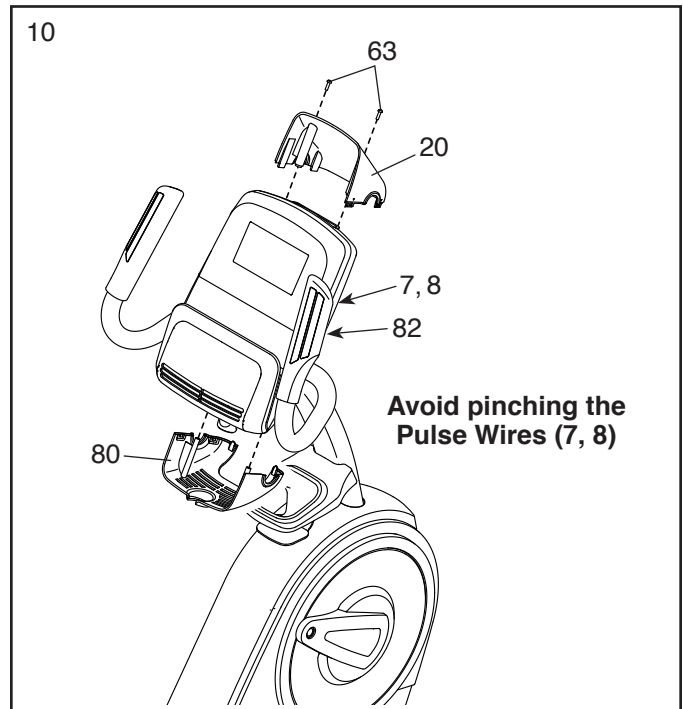

11. Attach the Seat Handlebar (18) to the Seat Carriage (11) with four M8 x 40mm Screws (56); **start all the Screws, and then tighten them.**

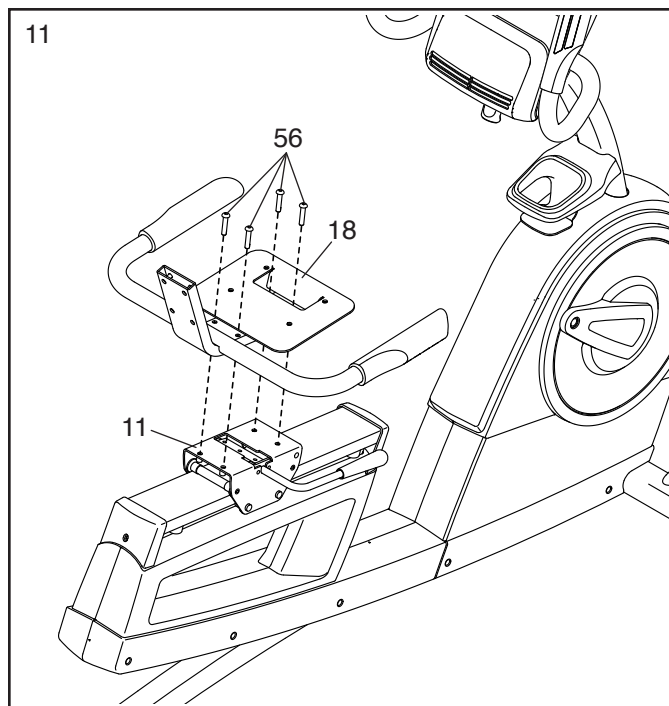

12. Slide the Backrest Frame (14) onto the Seat Handlebar (18).

Attach the Backrest Frame (14) with four M6 x 30mm Screws (51) and four M6 Washers (112); **start all the Screws, and then tighten them.**

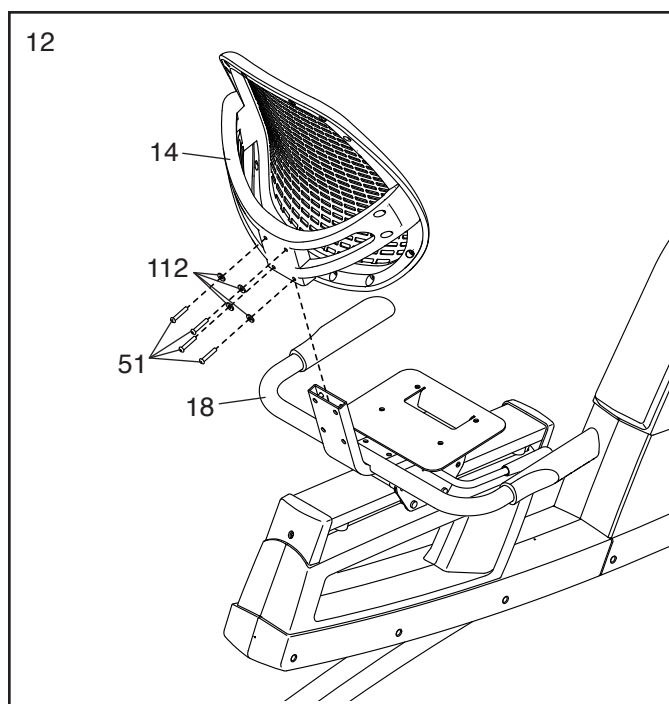

13. Attach the Seat (12) to the Seat Handlebar (18) with four M6 x 20mm Screws (67) and four M6 Washers (112) (only two of each are shown); **start all the Screws, and then tighten them.**

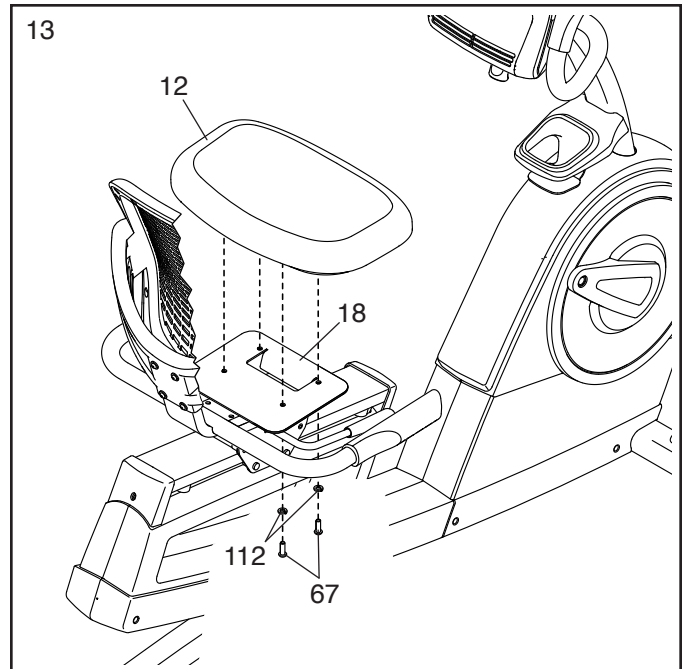

14. Identify the Right Pedal (29).

Using an adjustable wrench, **firmly tighten** the Right Pedal (29) **clockwise** into the Right Crank Arm (99).

Firmly tighten the Left Pedal (not shown) counterclockwise into the Left Crank Arm (not shown). IMPORTANT: You must turn the Left Pedal counterclockwise to attach it.

Attach the right pedal strap (C) to the Right Pedal (29) as shown. **Attach the left pedal strap (not shown) in the same way.**

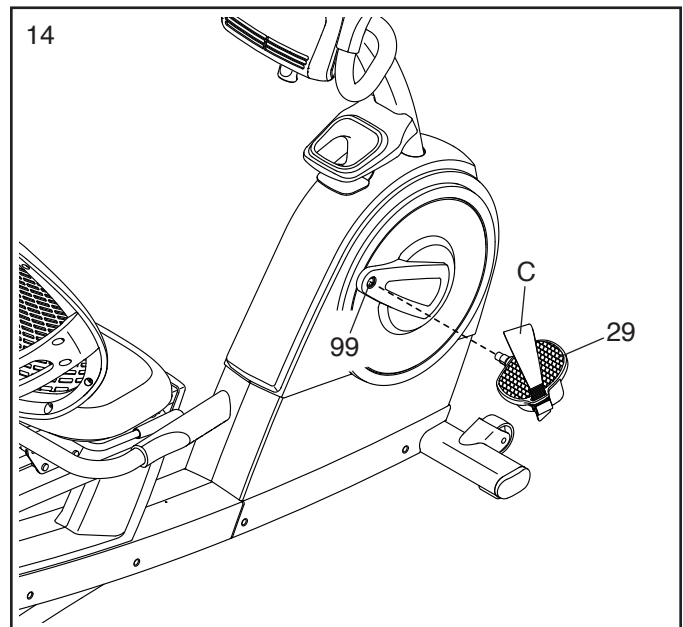

15. Plug the Power Adapter (107) into the receptacle on the frame of the exercise bike.

Note: To plug the Power Adapter (107) into an outlet, see HOW TO PLUG IN THE POWER ADAPTER on page 13.

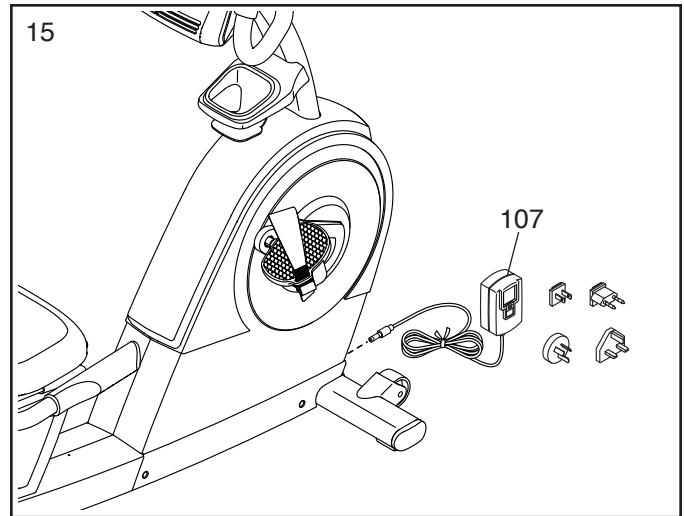

16. **After the exercise bike is assembled, inspect it to make sure that it is assembled correctly and that it functions properly. Make sure that all parts are properly tightened before you use the exercise bike.** Extra parts may be included. Place a mat beneath the exercise bike to protect the floor.

HOW TO USE THE EXERCISE BIKE

HOW TO PLUG IN THE POWER ADAPTER

IMPORTANT: If the exercise bike has been exposed to cold temperatures, allow it to warm to room temperature before you plug in the power adapter. If you do not do this, you may damage the console displays or other electronic components.

Plug the power adapter into the receptacle on the frame of the exercise bike. Insert the appropriate plug adapter into the power adapter if necessary. Then, plug the power adapter into an appropriate outlet that is properly installed in accordance with all local codes and ordinances.

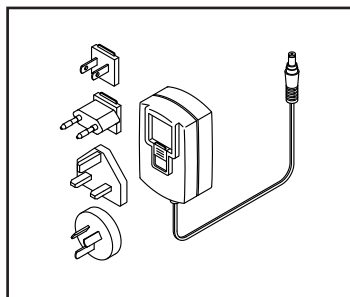

HOW TO ADJUST THE SEAT

The seat can be adjusted forward or backward to the position that is the most comfortable. To adjust the seat, push downward on the adjustment handle, slide the seat to the desired position, and then pull upward on the adjustment handle to lock the seat in place.

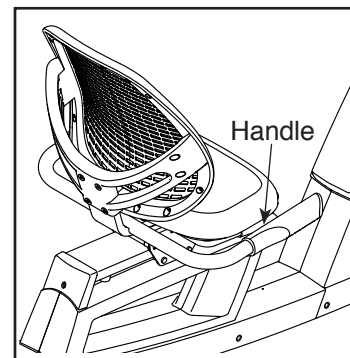

HOW TO ADJUST THE PEDAL STRAPS

To tighten a pedal strap, pull downward on the end of the strap. To loosen a strap, press the tab and pull upward on the strap.

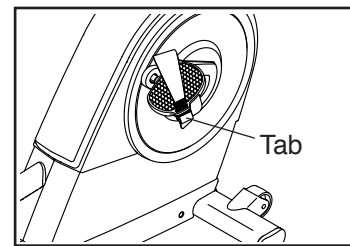

HOW TO MOVE THE EXERCISE BIKE

To move the exercise bike, hold the handle on the rear stabilizer and carefully lift it until the exercise bike can be moved on the front wheels. Carefully move the exercise bike to the desired location and then lower it.

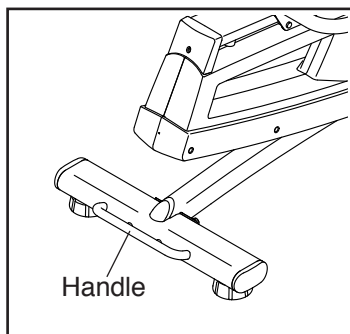

HOW TO LEVEL THE EXERCISE BIKE

If the exercise bike rocks slightly on your floor during use, turn one or both of the leveling feet beneath the rear stabilizer until the rocking motion is eliminated.

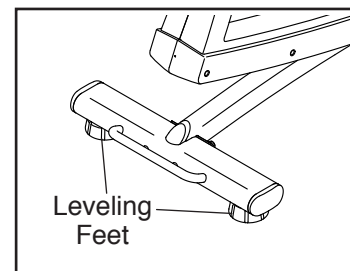

HOW TO ADJUST THE ANGLE OF THE CONSOLE

The console can be adjusted to several angles. To adjust the console, turn the console knob until the console is at the desired angle.

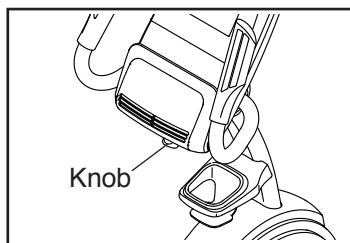

CONSOLE DIAGRAM

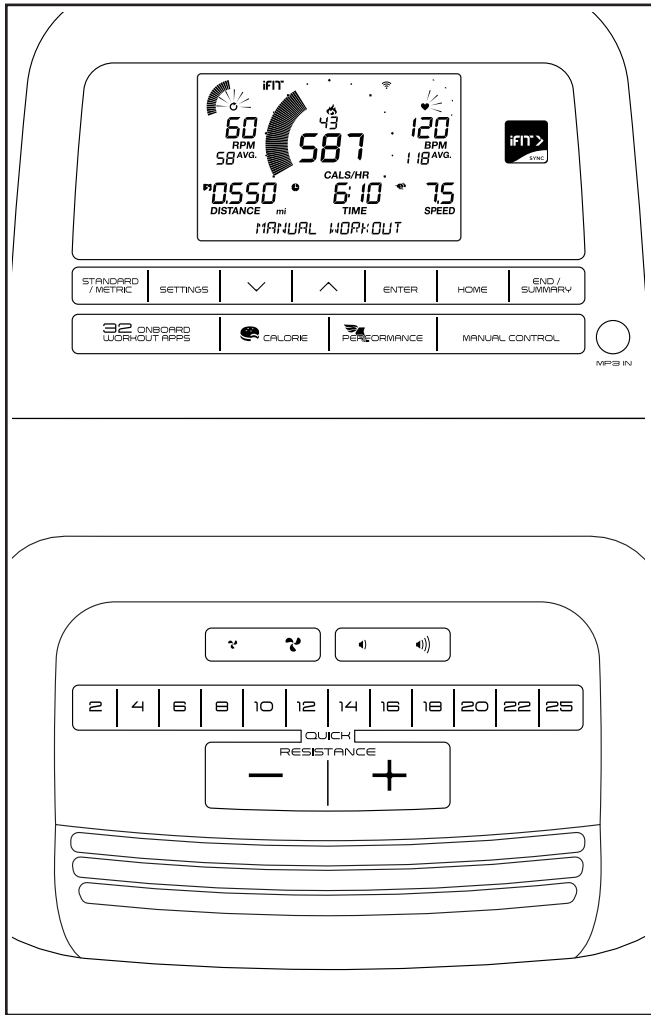

FEATURES OF THE CONSOLE

The advanced console offers an array of features designed to make your workouts more effective and enjoyable.

When you use the manual mode of the console, you can change the resistance of the pedals with the touch of a button.

While you exercise, the console will display continuous exercise feedback. You can also measure your heart rate using the handgrip heart rate monitor or a compatible heart rate monitor. **See page 20 for information about purchasing an optional chest heart rate monitor.**

You can also connect your tablet to the console and use the iFit® Bluetooth Tablet app to record and track your workout information.

The console also offers a selection of onboard workouts. Each workout automatically changes the resistance of the pedals as it guides you through an effective workout.

The watts workout changes the resistance of the pedals to keep your watts output near a target level.

You can even connect your personal audio player to the console sound system and listen to your favorite music or audio books while you exercise.

To use the manual mode, see page 15. **To use an onboard workout**, see page 17. **To use the watts workout**, see page 18. **To connect your tablet to the console**, see page 19. **To connect your heart rate monitor to the console**, see page 19. **To use the sound system**, see page 20. **To change console settings**, see page 20.

Note: If there is a sheet of plastic on the display, remove the plastic.

Note: The console can display speed and distance in either miles or kilometers. To change the unit of measurement, press the Standard/Metric button repeatedly. For simplicity, all instructions in this section refer to miles.

HOW TO USE THE MANUAL MODE

1. Turn on the console.

Begin pedaling or press any button on the console to turn on the console.

When you turn on the console, the displays will turn on, a tone will sound, and the console will be ready for use.

2. Select the manual mode.

Press the Manual Control button to select the manual mode.

3. Change the resistance of the pedals as desired.

As you pedal, change the resistance of the pedals by pressing the Quick Resistance increase and decrease buttons or by pressing one of the numbered Quick Resistance buttons.

Note: After you press a button, it will take a moment for the pedals to reach the selected resistance level.

4. Follow your progress with the displays.

The display can show the following workout information:

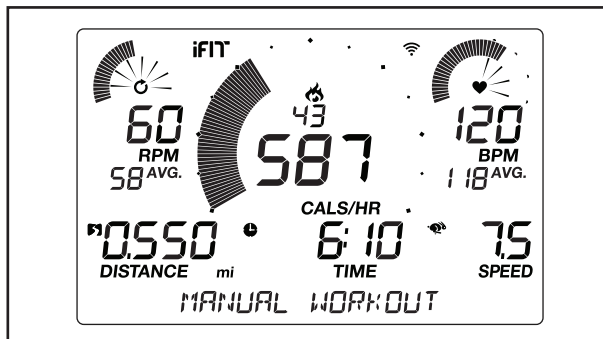

Calories (flame icon)—When the manual mode is selected, this display will show the approximate number of calories you have burned. When an onboard workout is selected, this display will show either the approximate number of calories remaining to be burned or the approximate number of calories you have burned.

Calories per Hour (Cals/Hr)—This display will show the approximate number of calories you are burning per hour.

Distance—This display will show the distance that you have pedaled in miles (mi) or kilometers (km).

Pulse (BPM)—This display will show your heart rate in beats per minute (bpm) when you use the handgrip heart rate monitor or the optional chest heart rate monitor (see step 5).

Pulse Average (BPM AVG)—This display will show your average heart rate in beats per minute (bpm) when you use the handgrip heart rate monitor or the optional chest heart rate monitor (see step 5).

Resistance—This display will show the resistance level of the pedals for a few seconds each time the resistance level changes.

RPM—This display will show your pedaling speed in revolutions per minute (rpm).

RPM Average (RPM AVG)—This display will show your average pedaling speed in revolutions per minute (rpm).

Speed—This display will show your pedaling speed in miles per hour or kilometers per hour. To change the unit of measurement, press the Standard/Metric button repeatedly.

Time—When the manual mode is selected, this display will show the elapsed time. When an onboard workout is selected, this display will show either the time remaining in the workout or the elapsed time.

Watts—This display will show your approximate power output in watts.

Average Watts (AVG)—This display will show your approximate average power output in watts for the workout.

Scan Mode and Priority

Mode—The calories and watts displays will appear in an alternating cycle (scan mode).

To select either the calories or the watts display for continuous display (priority mode), press the increase or decrease button next to the Enter button repeatedly until the desired display appears. To return to the scan mode, press the increase button repeatedly until the word SCAN appears.



Press the Home button to exit the workout and return to the main menu. If necessary, press the Home button again.

Press the End/Summary button to end the workout and view a workout summary. The workout summary will appear in the displays for several seconds.

Change the volume level of the console by pressing the volume increase and decrease buttons.



5. Measure your heart rate if desired.

You can measure your heart rate using either the handgrip heart rate monitor or an optional chest heart rate monitor (**see page 20 for information about the optional chest heart rate monitor**). Note: The console is compatible with BLUETOOTH® Smart heart rate monitors.

Note: If you use both heart rate monitors at the same time, the chest heart rate monitor will have priority.

If there are sheets of plastic on the metal contacts on the handgrip heart rate monitor, remove the plastic. To measure your heart rate, hold the handgrip heart rate monitor with your

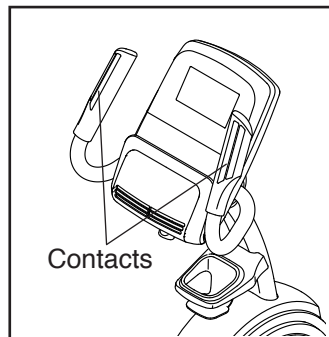

palms resting against the contacts. **Avoid moving your hands or gripping the contacts tightly.**

When your pulse is detected, your heart rate will appear in the display. **For the most accurate heart rate reading, hold the contacts for at least 15 seconds.**

6. Turn on the fan if desired.

The fan has several speed settings, including an auto mode. While the auto mode is selected, the speed of the fan will automatically increase or decrease as your exercise intensity increases or decreases. Press the fan increase and decrease buttons repeatedly to select a fan speed or to turn off the fan.

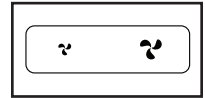

Note: If the pedals do not move for about 30 seconds, the fan will turn off automatically.

7. When you are finished exercising, the console will turn off automatically.

If the pedals do not move for several seconds, a series of tones will sound, the console will pause, and the display will pause.

If the pedals do not move for several minutes, the console will turn off and the display will be reset.

HOW TO USE AN ONBOARD WORKOUT

1. Turn on the console.

Begin pedaling or press any button on the console to turn on the console.

When you turn on the console, the displays will turn on, a tone will sound, and the console will be ready for use.

2. Select an onboard workout.

To select an onboard workout, press the desired Workout Apps button repeatedly until the desired workout appears in the display.

When you select an onboard workout, the display will show the name of the workout and the duration of the workout or the number of calories to be burned.

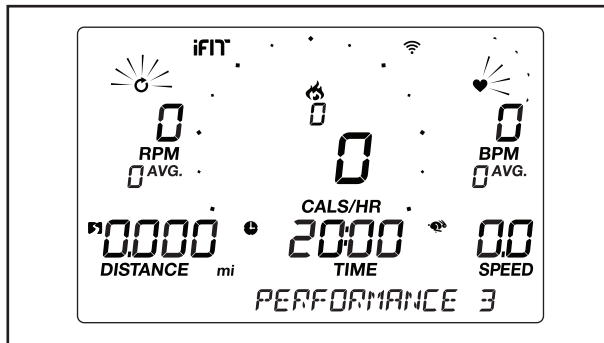

The maximum speed and the maximum resistance level for the workout will also appear in the display.

3. Begin pedaling to start the workout.

Each workout is divided into one-minute segments. One resistance level and one target speed is programmed for each segment. Note: The same resistance level and/or target speed may be programmed for consecutive segments.

At the end of each segment of the workout, a series of tones will sound. If a different resistance level and/or target speed is programmed for the

next segment, the resistance level and/or target speed will appear in the display to alert you. The resistance of the pedals will then change.

As you exercise, keep your pedaling speed near the target speed for the current segment.

IMPORTANT: The target speed is intended only to provide motivation. Your actual pedaling speed may be slower than the target speed. Make sure to pedal at a speed that is comfortable for you.

If the resistance level for the current segment is too high or too low, you can manually override the setting by pressing the Quick Resistance buttons.

IMPORTANT: When the current segment of the workout ends, the pedals will automatically adjust to the resistance level programmed for the next segment.

The workout will continue in this way until the last segment ends. To pause the workout at any time, stop pedaling. The time will flash in the display. To resume the workout, simply resume pedaling.

To end the workout, press the End/Summary button. A summary of the workout will appear in the displays for several seconds.

4. Follow your progress with the displays.

See step 4 on page 15.

5. Measure your heart rate if desired.

See step 5 on page 16.

6. Turn on the fan if desired.

See step 6 on page 16

7. When you are finished exercising, the console will turn off automatically.

See step 7 on page 16.

HOW TO USE THE WATTS WORKOUT

1. Turn on the console.

Begin pedaling or press any button on the console to turn on the console.

When you turn on the console, the displays will turn on, a tone will sound, and the console will be ready for use.

2. Select the watts workout.

To select the watts workout, press the Performance button repeatedly until you come to the last workout in the menu. The name of the watts workout and the target watts setting for the workout will appear in the displays.

3. Enter a target watts setting.

To enter a target watts setting, press the Quick Resistance increase and decrease buttons.

4. Begin pedaling to start the workout.

During the workout, the console will regularly compare your watts output to the target watts setting.

As you pedal, keep your watts output near the target watts setting by adjusting your pedaling speed.

If your watts output is too far below or above the target watts setting, the resistance of the pedals will automatically increase or decrease to bring your watts output closer to the target watts setting.

To change the target watts setting at any time during the workout, press the Quick Resistance increase and decrease buttons.

The workout will continue in this way indefinitely. To pause the console, simply stop pedaling. When the console is paused, the time will flash in the display. To continue your workout, simply resume pedaling.

5. Follow your progress with the displays.

See step 4 on page 15.

6. Measure your heart rate if desired.

See step 5 on page 16.

7. Turn on the fan if desired.

See step 6 on page 16

8. When you are finished exercising, the console will turn off automatically.

See step 7 on page 16.

HOW TO CONNECT YOUR TABLET TO THE CONSOLE

The console supports BLUETOOTH connections to tablets via the iFit Bluetooth Tablet app and to compatible heart rate monitors. Note: Other BLUETOOTH connections are not supported.

1. Download and install the iFit Bluetooth Tablet app on your tablet.

On your iOS® or Android™ tablet, open the App StoreSM or the Google Play™ store, search for the free iFit Bluetooth Tablet app, and then install the app on your tablet. **Make sure that the BLUETOOTH option is enabled on your tablet.**

Then, open the iFit Bluetooth Tablet app and follow the instructions to set up an iFit account and customize settings.

2. Connect your heart rate monitor to the console if desired.

If you are connecting both your heart rate monitor and your tablet to the console, **you must connect your heart rate monitor before you connect your tablet.** See HOW TO CONNECT YOUR HEART RATE MONITOR TO THE CONSOLE at the right.

3. Connect your tablet to the console.

Press the iFit Sync button on the console; the console pairing number will appear in the display. Then, follow the instructions in the iFit Bluetooth Tablet app to connect your tablet to the console.

When a connection is established, the LED on the console will turn solid blue.

4. Record and track your workout information.

Follow the instructions in the iFit Bluetooth Tablet app to record and track your workout information.

5. Disconnect your tablet from the console if desired.

To disconnect your tablet from the console, first select the disconnect option in the iFit Bluetooth Tablet app. Then, press and hold the iFit Sync button on the console until the LED on the console turns solid green.

Note: All BLUETOOTH connections between the console and other devices (including any tablets, heart rate monitors, and so forth) will be disconnected.

HOW TO CONNECT YOUR HEART RATE MONITOR TO THE CONSOLE

The console is compatible with all BLUETOOTH Smart heart rate monitors.

To connect your BLUETOOTH Smart heart rate monitor to the console, press the iFit Sync button on the console; the console pairing number will appear in the display. When a connection is established, the LED on the console will flash red twice.

Note: If there is more than one compatible heart rate monitor near the console, the console will connect to the heart rate monitor with the strongest signal.

To disconnect your heart rate monitor from the console, press and hold the iFit Sync button on the console until the LED on the console turns solid green.

Note: All BLUETOOTH connections between the console and other devices (including any tablets, heart rate monitors, and so forth) will be disconnected.

HOW TO USE THE SOUND SYSTEM

To play music or audio books through the console sound system while you exercise, plug a 3.5 mm male to 3.5 mm male audio cable (not included) into the jack on the console and into a jack on your personal audio player; **make sure that the audio cable is fully plugged in. Note: To purchase an audio cable, see your local electronics store.**

Next, press the play button on your personal audio player. Adjust the volume level using the volume increase and decrease buttons on the console or the volume control on your personal audio player.



THE OPTIONAL CHEST HEART RATE MONITOR

Whether your goal is to burn fat or to strengthen your cardiovascular system, the key to achieving the best results is to maintain the proper heart rate during your workouts. The optional chest heart rate monitor will enable you to continuously monitor your heart rate while you exercise, helping you to reach your personal fitness goals. **To purchase a chest heart rate monitor, please see the front cover of this manual.**

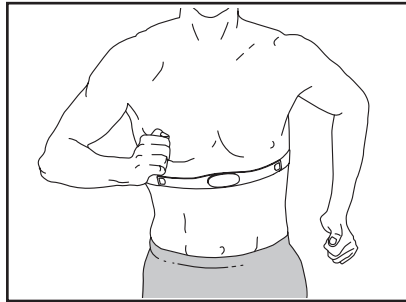

Note: The console is compatible with all BLUETOOTH Smart heart rate monitors.

HOW TO CHANGE CONSOLE SETTINGS

1. Select the settings mode.

To select the settings mode, press the Settings button. The settings information will appear in the display.

2. Navigate the settings mode.

While the settings mode is selected, the display will show several optional screens. Press the increase and decrease buttons near the Enter button repeatedly to select the desired optional screen.

The lower section of the display will show instructions for the selected screen. **Make sure to follow the instructions shown in the lower part of the display.**

3. Change settings as desired.

Units—The currently selected unit of measurement will appear in the display. To change the unit of measurement, press the Enter button repeatedly. To view distance in miles, select ENGLISH. To view distance in kilometers, select METRIC.

Contrast Level—The currently selected contrast level will appear in the display. Press the Quick Resistance increase and decrease buttons to adjust the contrast level.

Usage Information—The display will show the total number of hours that the exercise bike has been used and the total distance (in miles or kilometers) that has been pedaled on the exercise bike.

4. Exit the settings mode.

Press the Settings button to exit the settings mode.

MAINTENANCE AND TROUBLESHOOTING

MAINTENANCE

Regular maintenance is important for optimal performance and to reduce wear. Inspect and properly tighten all parts each time the exercise bike is used. Replace any worn parts immediately.

To clean the exercise bike, use a damp cloth and a small amount of mild soap. **IMPORTANT: To avoid damage to the console, keep liquids away from the console and keep the console out of direct sunlight.**

CONSOLE TROUBLESHOOTING

If the console does not turn on, make sure that the power adapter is fully plugged in.

If the console does not display your heart rate when you use the handgrip heart rate monitor, see step 5 on page 16.

If a replacement power adapter is needed, call the telephone number on the cover of this manual. IMPORTANT: To avoid damaging the console, use only a manufacturer-supplied regulated power adapter.

HOW TO ADJUST THE DRIVE BELT

If the pedals slip while you are pedaling, even while the resistance is adjusted to the highest setting, the drive belt may need to be adjusted. **Before you adjust the drive belt, unplug the power adapter.**

With the help of a second person, carefully lay the exercise bike on its side.

Next, tighten the indicated M8 Hex Nut (113) slightly to tighten the Drive Belt (not shown). Then, with the help of a second person, return the exercise bike to the upright position. Plug in the power adapter.

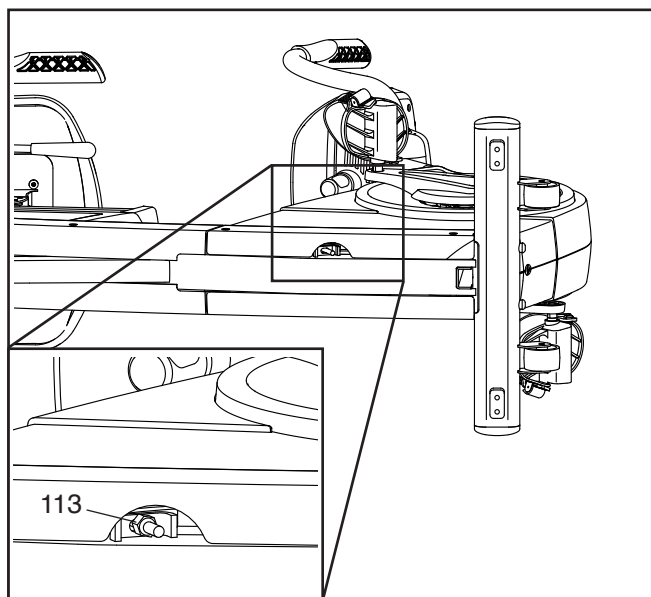

Repeat this process, if necessary, until the pedals no longer slip.

HOW TO ADJUST THE REED SWITCH

If the console does not display correct feedback, the reed switch should be adjusted. **Before you adjust the reed switch, unplug the power adapter.**

Using a small standard screwdriver, carefully pry the left Crank Cover (25) off the left Shield Cover (24). Next, remove the two M5 x 20mm Screws (53). Then, rotate the left Shield Cover out of the way.

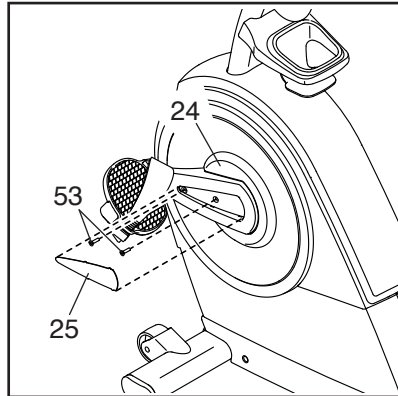

Note: For clarity, the left pedal and the left shield cover are shown removed in the drawing at the right.

Locate the Reed Switch (35). Rotate the Left Crank Arm (100) until a Magnet (39) is aligned with the Reed Switch. Next, loosen the Clamp Screw (A), slide the Reed Switch slightly toward or away from the Magnet, and then retighten the Clamp Screw.

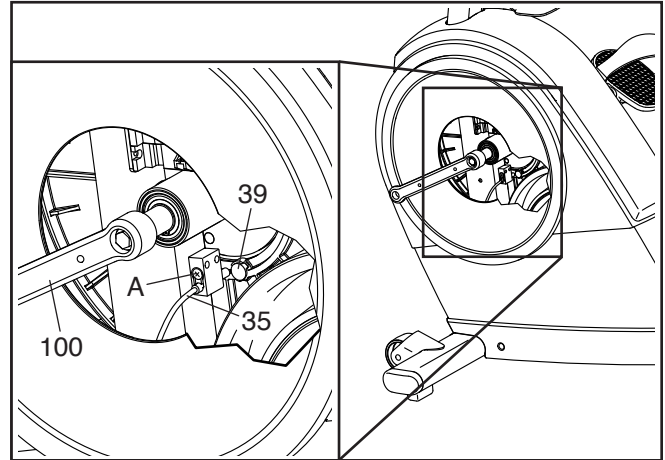

Plug in the power adapter and rotate the Left Crank Arm (100) for a moment. Repeat these actions until the console displays correct feedback.

When the reed switch is correctly adjusted, reattach the parts that you removed.

EXERCISE GUIDELINES

⚠️ WARNING: Before beginning this or any exercise program, consult your physician. This is especially important for persons over age 35 or persons with pre-existing health problems.

The heart rate monitor is not a medical device. Various factors may affect the accuracy of heart rate readings. The heart rate monitor is intended only as an exercise aid in determining heart rate trends in general.

These guidelines will help you to plan your exercise program. For detailed exercise information, obtain a reputable book or consult your physician. Remember, proper nutrition and adequate rest are essential for successful results.

EXERCISE INTENSITY

Whether your goal is to burn fat or to strengthen your cardiovascular system, exercising at the proper intensity is the key to achieving results. You can use your heart rate as a guide to find the proper intensity level. The chart below shows recommended heart rates for fat burning and aerobic exercise.

165	155	145	140	130	125	115	❤️
145	138	130	125	118	110	103	❤️
125	120	115	110	105	95	90	❤️
<hr/>							
20	30	40	50	60	70	80	

To find the proper intensity level, find your age at the bottom of the chart (ages are rounded off to the nearest ten years). The three numbers listed above your age define your “training zone.” The lowest number is the heart rate for fat burning, the middle number is the heart rate for maximum fat burning, and the highest number is the heart rate for aerobic exercise.

Burning Fat—To burn fat effectively, you must exercise at a low intensity level for a sustained period of time. During the first few minutes of exercise, your body uses carbohydrate calories for energy. Only after the first few minutes of exercise does your body begin to use stored fat calories for energy. If your goal is to burn fat, adjust the intensity of your exercise until your heart rate is near the lowest number in your training zone. For maximum fat burning, exercise with your heart rate near the middle number in your training zone.

Aerobic Exercise—If your goal is to strengthen your cardiovascular system, you must perform aerobic exercise, which is activity that requires large amounts of oxygen for prolonged periods of time. For aerobic exercise, adjust the intensity of your exercise until your heart rate is near the highest number in your training zone.

WORKOUT GUIDELINES

Warming Up—Start with 5 to 10 minutes of stretching and light exercise. A warm-up increases your body temperature, heart rate, and circulation in preparation for exercise.

Training Zone Exercise—Exercise for 20 to 30 minutes with your heart rate in your training zone. (During the first few weeks of your exercise program, do not keep your heart rate in your training zone for longer than 20 minutes.) Breathe regularly and deeply as you exercise; never hold your breath.

Cooling Down—Finish with 5 to 10 minutes of stretching. Stretching increases the flexibility of your muscles and helps to prevent post-exercise problems.

EXERCISE FREQUENCY

To maintain or improve your condition, complete three workouts each week, with at least one day of rest between workouts. After a few months of regular exercise, you may complete up to five workouts each week, if desired. Remember, the key to success is to make exercise a regular and enjoyable part of your everyday life.

PART LIST

Model No. NTEVEX76017.0 R0517A

Key No.	Qty.	Description	Key No.	Qty.	Description
1	1	Frame	50	2	M10-1.0 Flange Nut
2	1	Front Stabilizer	51	8	M6 x 30mm Screw
3	1	Rear Stabilizer	52	20	M4 x 25mm Screw
4	1	Upright	53	4	M5 x 20mm Screw
5	1	Console	54	2	M10 x 55mm Screw
6	1	Left Handlebar	55	4	Resistance Motor Screw
7	1	Left Pulse Sensor/Wire	56	4	M8 x 40mm Screw
8	1	Right Pulse Sensor/Wire	57	2	Wheel
9	1	Accessory Tray	58	1	Power Wire
10	1	Rail	59	1	Drive Belt
11	1	Seat Carriage	60	4	M10 x 20mm Screw
12	1	Seat	61	1	M4 x 19mm Bright Screw
13	1	Backrest	62	6	M6 x 10mm Screw
14	1	Backrest Frame	63	23	M4 x 15mm Screw
15	1	Seat Handle	64	1	Rear Rail Cover
16	1	Seat Lever	65	1	Front Rail Cover
17	1	Brake Bracket	66	4	Bumper
18	1	Seat Handlebar	67	8	M6 x 20mm Screw
19	1	Upright Cover	68	13	M6 Small Washer
20	1	Upper Bracket Cover	69	2	Upper Roller
21	1	Left Shield	70	4	Lower Roller
22	1	Right Shield	71	2	Axle
23	2	Lock Ring	72	1	Brake
24	2	Shield Cover	73	1	Brake Block
25	2	Crank Cover	74	3	M10 Locknut
26	2	Rear Stabilizer Cap	75	2	M10 x 45mm Screw
27	2	Stabilizer Foot	76	5	M6 Split Washer
28	2	Leveling Foot	77	2	Brake Spacer
29	1	Right Pedal/Strap	78	1	Grommet
30	1	Left Pedal/Strap	79	1	Accessory Tray Bracket
31	1	Eddy Mechanism	80	1	Lower Bracket Cover
32	1	Idler	81	1	Right Handlebar
33	1	Resistance Motor	82	1	Console Bracket
34	1	Resistance Cable	83	1	Adjustment Knob
35	1	Reed Switch/Wire	84	1	Upright Bracket
36	11	M4 x 19mm Screw	85	1	Upper Block
37	1	Clamp	86	1	Lower Block
38	2	Crank Bearing	87	2	Console Bracket Bushing
39	2	Magnet	88	2	Upright Bracket Bushing
40	1	Pulley	89	4	M8 x 14mm Screw
41	1	Main Wire	90	1	Right Seat Handgrip
42	1	M6 x 50mm Screw	91	1	Pivot Axle
43	1	Right Rear Shield	92	2	M8 Large Washer
44	2	M10 x 120mm Screw	93	1	Left Seat Handgrip
45	1	Idler Screw	94	6	M8 x 13mm Screw
46	1	Left Rear Shield	95	6	M8 Nut
47	7	M8 x 20mm Screw	96	1	M10 x 130mm Bolt
48	1	M8 Thin Washer	97	2	M10 Flange Nut
49	2	M8 x 50mm Bolt	98	1	M8 Washer

Key No.	Qty.	Description	Key No.	Qty.	Description
99	1	Right Crank Arm	108	4	M8 Split Washer
100	1	Left Crank Arm	109	2	Front Stabilizer Cap
101	2	M10 x 60mm Bolt	110	2	M10 x 96mm Screw
102	7	M8 Locknut	111	4	M4 x 30mm Screw
103	3	M6 x 15mm Screw	112	8	M6 Washer
104	2	Crank Snap Ring	113	1	M8 Hex Nut
105	1	Crank	*	–	User's Manual
106	1	Frame Cap	*	–	Assembly Tool
107	1	Power Adapter			

Note: Specifications are subject to change without notice. For information about ordering replacement parts, see the back cover of this manual. *These parts are not illustrated.

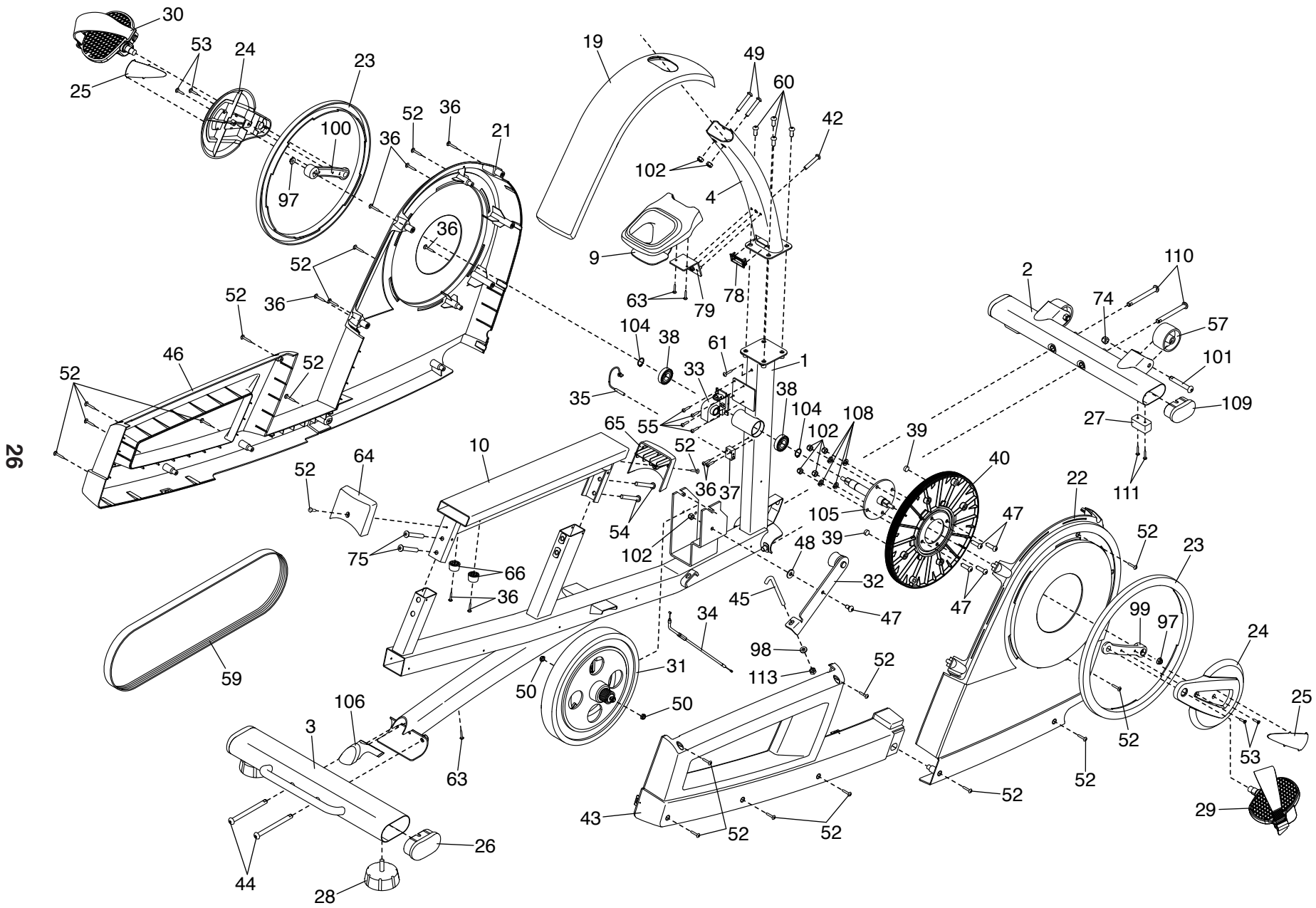

EXPLODED DRAWING A

Model No. NTEVEX76017.0 R0517A

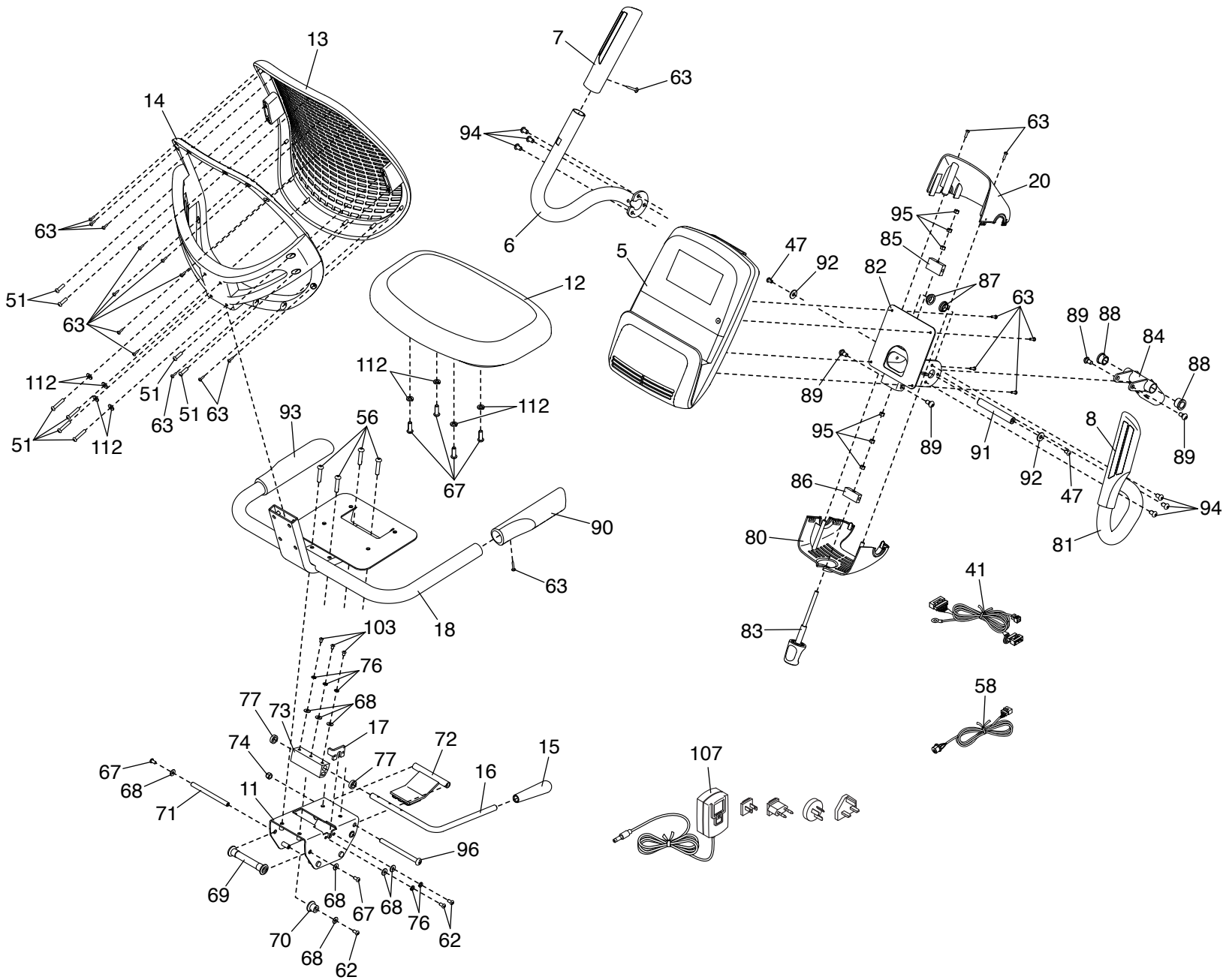

EXPLODED DRAWING B

Model No. NTEVEX76017.0 R0517A

ORDERING REPLACEMENT PARTS

To order replacement parts, please see the front cover of this manual. To help us assist you, be prepared to provide the following information when contacting us:

- the model number and serial number of the product (see the front cover of this manual)
- the name of the product (see the front cover of this manual)
- the key number and description of the replacement part(s) (see the PART LIST and the EXPLODED DRAWING near the end of this manual)

RECYCLING INFORMATION

This electronic product must not be disposed of in municipal waste. To preserve the environment, this product must be recycled after its useful life as required by law.

Please use recycling facilities that are authorized to collect this type of waste in your area. In doing so, you will help to conserve natural resources and improve European standards of environmental protection. If you require more information about safe and correct disposal methods, please contact your local city office or the establishment where you purchased this product.

