



**DRAPER**<sup>®</sup>

# 400 SERIES **CLAMP METER**

41864



**IMPORTANT:** Please read these instructions carefully to ensure the safe and effective use of this product and save these instructions for future reference. This manual has been compiled by Draper Tools and is an integrated part of the product with which it is enclosed and should be kept with it for future references.

This manual describes the purpose for which the product has been designed and contains all the necessary information to ensure its correct and safe use. We recommend that this manual is read before any operation or, before performing any kind of adjustment to the product and prior to any maintenance tasks. By following all the general safety instructions contained in this manual, it will ensure both product and operator safety, together with longer life of the product itself.

All photographs and drawings in this manual are supplied by Draper Tools to help illustrate the operation of the product. Whilst every effort has been made to ensure accuracy of information contained in this manual, the Draper Tools policy of continuous improvement determines the right to make modifications without prior warning.

# 1. TITLE PAGE

---

## 1.1 INTRODUCTION:

USER MANUAL FOR:

### SERIES 400 CLAMP METER

Stock no. 41864.

Part no. DCM400.

## 1.2 REVISIONS:

---

Date first published March 2017

---

Date second published June 2017

---

---

As our user manuals are continually updated, users should make sure that they use the very latest version.

Downloads are available from: <http://www.drapertools.com/manuals>

DRAPER TOOLS LIMITED

HURSLEY ROAD

CHANDLER'S FORD

EASTLEIGH

HAMPSHIRE

SO53 1YF

UK

WEBSITE:

[drapertools.com](http://drapertools.com)

PRODUCT HELPLINE:

+44 (0) 23 8049 4344

GENERAL FAX:

+44 (0) 23 8026 0784

## 1.3 UNDERSTANDING THIS MANUALS SAFETY CONTENT:

**WARNING!** Information that draws attention to the risk of injury or death.

**CAUTION!** Information that draws attention to the risk of damage to the product or surroundings.

## 1.4 COPYRIGHT © NOTICE:

Copyright © Draper Tools Limited.

Permission is granted to reproduce this publication for personal & educational use only.

Commercial copying, redistribution, hiring or lending is prohibited.

No part of this publication may be stored in a retrieval system or transmitted in any other form or means without written permission from Draper Tools Limited.

In all cases this copyright notice must remain intact.

## 2.1 CONTENTS

<b>Page content</b> .....	<b>Page</b>
1 TITLE PAGE	
1.1 INTRODUCTION .....	2
1.2 REVISION HISTORY .....	2
1.3 UNDERSTANDING THIS MANUAL .....	2
1.4 COPYRIGHT NOTICE .....	2
2 CONTENTS	
2.1 CONTENTS .....	3
3 GUARANTEE	
3.1 GUARANTEE .....	4
4 INTRODUCTION	
4.1 GENERAL SPECIFICATIONS .....	5-7
5 HEALTH & SAFETY INFORMATION	
5.1 SAFETY PRECAUTIONS .....	8
6 IDENTIFICATION	
6.1 LCD .....	10
7 UNPACKING & CHECKING	
7.1 PACKAGING .....	11
7.2 WHAT'S IN THE BOX .....	11
8 OPERATION INSTRUCTIONS	
8.1 BACKLIGHT AND INSPECTION LIGHT .....	12
8.2 FUNCTION SWITCH BUTTON (SEL) .....	12
8.3 MAX READINGS MAXIMUM VALUE DISPLAY .....	12
8.4 AUTO/MANUAL SWITCH BUTTON (RAN) .....	12
8.5 AC CURRENT MEASUREMENT USING CURRENT CLAMP HEAD .....	12
8.6 DC VOLTAGE MEASUREMENT .....	12
8.7 AC VOLTAGE MEASUREMENT .....	13
8.8 RESISTANCE MEASUREMENT .....	13
8.9 CONTINUITY/ DIODE TEST .....	13
8.10 HOLDING READINGS .....	13
9 MAINTENANCE	
9.1 REPLACEMENT BATTERY .....	14
10 EXPLANATION OF SYMBOLS	
10.1 EXPLANATION OF SYMBOLS .....	15
11 DISPOSAL	
11.1 DISPOSAL .....	16
DECLARATION OF CONFORMITY .....	ENCLOSED

# 3. GUARANTEE

---

## 3.1 GUARANTEE

Draper tools have been carefully tested and inspected before shipment and are guaranteed to be free from defective materials and workmanship.

Should the tool develop a fault, please return the complete tool to your nearest distributor or contact Draper Tools Limited, Chandler's Ford, Eastleigh, Hampshire, SO53 1YF.

England.

Telephone Sales Desk: (023) 8049 4333 or Product Helpline (023) 8049 4344.

A proof of purchase must be provided with the tool.

If upon inspection it is found that the fault occurring is due to defective materials or workmanship, repairs will be carried out free of charge. This guarantee period covering parts/labour is 12 months from the date of purchase except where tools are hired out when the guarantee period is 90 days from the date of purchase. This guarantee does not apply to normal wear and tear, nor does it cover any damage caused by misuse, careless or unsafe handling, alterations, accidents, or repairs attempted or made by any personnel other than the authorised Draper warranty repair agent.

Note: If the tool is found not to be within the terms of warranty, repairs and carriage charges will be quoted and made accordingly.

This guarantee applies in lieu of any other guarantee expressed or implied and variations of its terms are not authorised.

Your Draper guarantee is not effective unless you can produce upon request a dated receipt or invoice to verify your proof of purchase within the guarantee period.

Please note that this guarantee is an additional benefit and does not affect your statutory rights.

Draper Tools Limited.

## 4.1 GENERAL SPECIFICATIONS

Voltage input and ground between the maximum voltage CAT III  
600V $\sim$  & 600V $\sim$

Display: LCD display, the maximum reading of 1999

Measurement principle: double integral A / D conversion

Range selection: Automatic

Measurement rate: (2.5 times to 3 times) / sec

Unit display: with the function, the unit of electricity symbol display

Polarity display: Negative polarity input shows “ — ”

Over range display: "OL"

Data hold function: LCD display “ H ”

Low battery indicator: LCD upper left shows “ ”

Power supply battery: DC1.5V X3 SIZE AAA.

Dimensions: 208mm × 79mm × 36mm

Weight: no more than 333g (including battery)

Jaw opening maximum size: 36mm

Operating temperature: 5 °C ~ 35 °C

Storage temperature: -10 °C ~ 50 °C

## DC Voltage

Range	Accuracy	Resolution
200mV	$\pm(0.8\% \text{ rdg} + 2 \text{ digit})$	0.1mV
2V		1mV
20V		10mV
200V		0.1V
600V	$\pm(1.0\% \text{ rdg} + 2 \text{ digit})$	1V

Input impedance: 10M $\Omega$ .

Maxi allowable input voltage: 600V DC or 600V AC rms.

## 4. INTRODUCTION

---

### AC Voltage

Range	Accuracy	Resolution
200mV	$\pm(1.0\% \text{ rdg} + 10 \text{ digit})$	0.1mV
2V		1mV
20V		10mV
200V		0.1V
600V	$\pm(1.2\% \text{ rdg} + 10 \text{ digit})$	1V

Input impedance: 10M $\Omega$

Measuring frequency range: 40Hz~400Hz.

Maxi allowable input voltage: 600V DC or 600 V AC rms.

### AC Current

Range	Accuracy	Resolution
2A	$\pm(3.5\% \text{ rdg} + 20 \text{ digit}) \leq 0.5\text{A}$	0.001A
	$\pm(3.0\% \text{ rdg} + 10 \text{ digit})$	
20A	$\pm(3.0\% \text{ rdg} + 10 \text{ digit}) \leq 5\text{A}$	0.01A
	$\pm(2.5\% \text{ rdg} + 10 \text{ digit})$	
200A	$\pm(2.5\% \text{ rdg} + 10 \text{ digit})$	0.1A
600A	$\pm(1.5\% \text{ rdg} + 5 \text{ digit})$	1A

Measuring frequency range: 50Hz ~ 60Hz.

Maxi allowable input current: full value 120%, no more than 60 seconds.

### Resistance

Range	Accuracy	Resolution
200 $\Omega$	$\pm(1.2\% \text{ rdg} + 2 \text{ digit})$	0.1 $\Omega$
2k $\Omega$		0.001k $\Omega$
20k $\Omega$		0.01k $\Omega$
200k $\Omega$		0.1k $\Omega$
2M $\Omega$		0.001M $\Omega$
20M $\Omega$	$\pm(2.0\% \text{ rdg} + 5 \text{ digit})$	0.01M $\Omega$

Overload Protection: 250V DC or 250V AC rms.

### Diode Test

Range	Accuracy	Resolution
	Displays the forward pressure drop approximation (Open circuit voltage of about 1.5V)	1mV

Overload Protection: 250V DC or 250V AC rms.

### Continuity Test

Range	Accuracy	Resolution
	The buzzer will sound when about $\leq 60\Omega$ (open circuit voltage of about 0.45V)	100m $\Omega$

Note: The buzzer may sound or not sound at 60 $\Omega$  to 120 $\Omega$ , and the buzzer does not sound when it is greater than 120 $\Omega$ .

Overload protection: 250V DC or 250V AC rms.

# 5. HEALTH & SAFETY INFORMATION

---

## **Warning**

To avoid electrical shock or personal injury.  
Please read the safety information and “warnings and precautions” before use.

This is an AC-DC current digital clamp meter (hereinafter referred to as the clamp meter). The whole circuit design is based on LSI A / D converter with full-scale overload protection circuit and frequency measurement function.

The Clamp Meter can be used to measure the AC and DC voltage, AC and DC current, resistance, capacitance, frequency, duty cycle, diodes and temp.

### **5.1 SAFETY PRECAUTIONS**

The instrument strictly follows the GB4793 electronic measuring instrument safety requirements IEC61010-1 and IEC1010-2-032 safety standards for the design and production, in line with double insulation, over-voltage CAT III 600V and pollution level 2 safety standards.

#### **Safe working habits**

To avoid possible electric shock or personal injury, and to avoid damage to the instrument or the object to be measured, use the meter in the following ways:

- Inspect the instrument. Do not use the instrument if the case is damaged. Check for cracks or missing plastic parts. Pay particular attention to the insulating layer of the connector.
- Inspect the test leads for insulation damage or bare metal. Check the continuity of the test leads. If the test leads are damaged, replace them before using the instrument.
- Use the instrument to measure a known voltage to make sure the instrument operates normally. Do not use if the instrument is working abnormally. Protection facilities may have been damaged. If in doubt, the instrument should be sent for maintenance.
- Do not apply any voltage beyond the rated voltage indicated on the meter between any terminal and earth ground.
- Warning: When working above 30V use caution not to touch exposed contacts due to risk of electric shock. Only use the approved probes or clamps.
- Measurements must be made with the correct jack, function and range.
- Do not use the instrument near explosive gases, vapours or dust.
- When using the test leads, keep your fingers behind the test lead protector.
- When connecting, first connect the common test lead, and then connect the live test lead. When disconnect, the live test lead and then disconnect the common test lead.
- Before you test the resistance, continuity and diodes, you must first cut off the power, and discharge all the capacitors.
- If the meter is not used in accordance with the instructions, the safety protection provided by the instrument may be impaired or invalidated.
- Ensure the instrument is switched off when opening the battery cover.
- When the battery under voltage indicator  lights up, immediately replace the battery. When the battery power is low, the meter may produce incorrect readings, resulting in electric shock and personal injury. DO NOT mix new and old batteries and do not use re-chargeable batteries.
- Before opening the battery cover, the test leads must be removed from the instrument.
- Please use a soft cloth to clean instrument case, do not use abrasives or solvents.

## 6. IDENTIFICATION



- ① Measurement clamp head.
- ② Inspection light.
- ③ Protection Guard: Protects the user's hand from touching the danger zone.
- ④ Clamp trigger.
- ⑤ Measuring function selection dial.
- ⑥ Back light/inspection light button.
- ⑦ Function buttons.
- ⑧ Display.
- ⑨ Probe sockets.

## 6. IDENTIFICATION

### 6.1 LCD (Liquid-crystal display) - FIG. 1

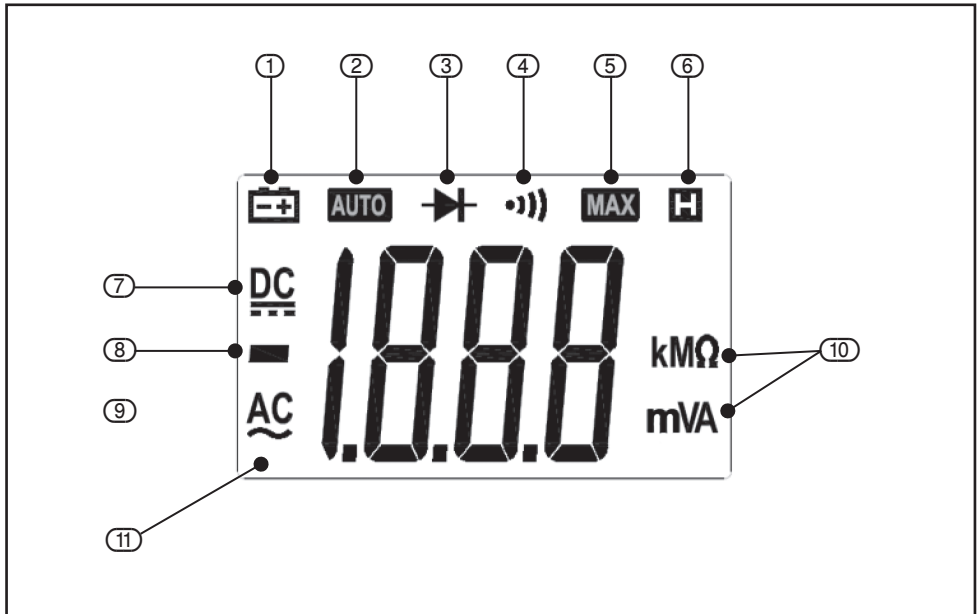

FIG.1

- |                                  |                                    |
|----------------------------------|------------------------------------|
| ① Battery low indicator.         | ⑦ DC Signal Measurement Indicator. |
| ② Automatic range indicator.     | ⑧ Negative polarity indicator.     |
| ③ Diode measurement indicator.   | ⑨ AC signal indicator.             |
| ④ Continuity checking indicator. | ⑩ Unit indicator.                  |
| ⑤ Maximum measurement indicator. | ⑪ Numerical display.               |
| ⑥ Data hold indicator.           |                                    |

# 7. UNPACKING & CHECKING

## 7.1 PACKAGING

Carefully remove the product from the packaging and examine it for any sign of damage caused during shipping. Lay the contents out and check them. If any part is damaged or missing, do not attempt to use the tool and contact the Draper Helpline immediately (see back page for details).

Retain the packaging material at least during the guarantee period: in case the machine needs to be returned for repair.

Warning! Some of the packaging materials used may be harmful to children, keep them out of reach from children.

Disposed of any packaging correctly and according to local regulations.

## 7.2 WHAT'S IN THE BOX?

As well as the product; there are several parts not fitted or attached to it.

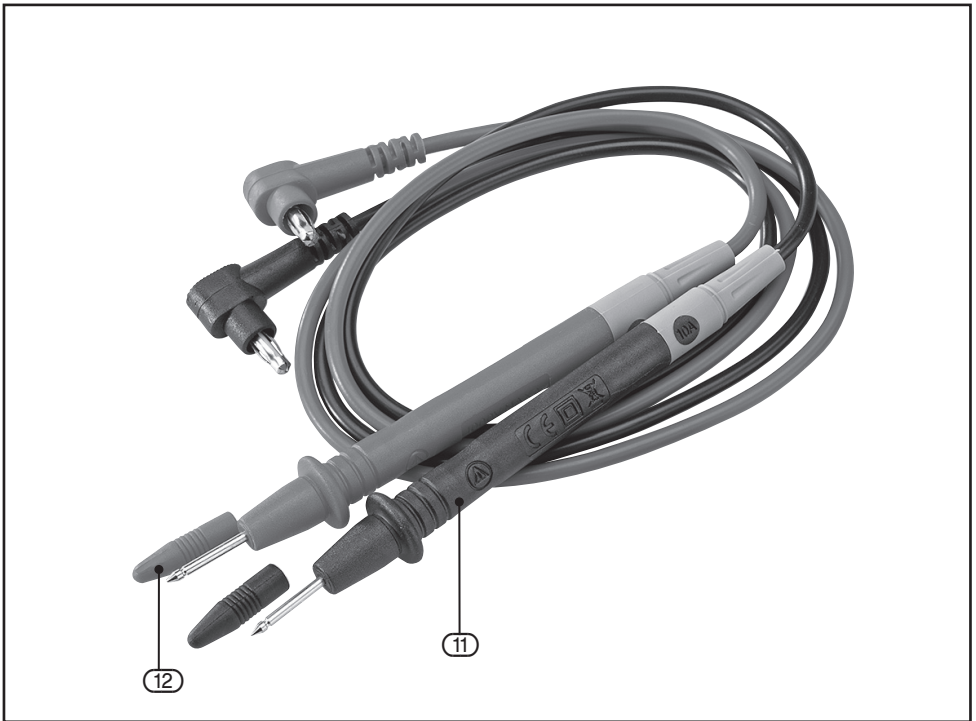

①① Test probe

①② Test probe caps

# 8. OPERATING INSTRUCTIONS

---

## 8.1 BACKLIGHT AND INSPECTION LIGHT

Press and hold the "\*" button to switch on and off the back light/inspection light.

Note: The inspection light will only come on while in AC current function.

## 8.2 FUNCTION SWITCH BUTTON (SEL)

The "SEL" button is for switching between DCV/ACV, also between diode and continuity measuring.

## 8.3 MAX READINGS MAXIMUM VALUE DISPLAY

Press the "MAX" key to display the maximum value of measurement data on the display.

## 8.4 AUTO/MANUAL SWITCH BUTTON (RAN)

At the voltage, resistance measurement ranges, clamp meter defaults to auto range. Press this button to switch to manual range. In the manual range, press this button that means jump upwards one section, if the highest section jumps to the lowest section. Press and hold this button for more than 2 seconds, that is, switch back to automatic range.

## 8.5 AC CURRENT MEASUREMENT USING CURRENT CLAMP HEAD.

### Warning

**YOU MUST NOT measure current using the probes.**

**Remove the test leads from the meter when measuring with the clamp head.**

1. Rotate the measurement function selection dial to the appropriate current.
2. Press the trigger to open the clamp, pass the wire to be measured into the centre of the clamp, and then slowly release the trigger until the clamp is fully closed.
3. Read the measurement result from the LCD.

Note: The instrument can only measure one current conductor at a time.

If two or more current conductors are measured at the same time, the measurement will be inaccurate.

## 8.6 DC VOLTAGE MEASUREMENT

### Warning

**Risk of electric shock.**

**When measuring high voltage, extra care should be taken to avoid electrical shock.**

**Do not attempt to use this meter on a voltage higher than DC600V rms.**

1. Rotate the measurement function selection dial to the DC voltage measurement.
2. Connect the black lead to the COM probe socket and the red lead to the INPUT probe socket.
3. The measured value is read from the LCD. The polarity display will indicate the polarity of the terminals to which the red test is connected.

## 8. OPERATING INSTRUCTIONS

---

### 8.7 AC VOLTAGE MEASUREMENT

#### Warning

**Risk of electric shock.**

**When measuring high voltage, extra care should be taken to avoid electrical shock.**

**Do not attempt to use this meter on a voltage higher than the AC600V rms value.**

1. Rotate the measurement function selection dial to the AC voltage measurement.
2. Connect the black lead to the COM probe socket and the red lead to the INPUT probe socket.
3. The measured value is read from the LCD.

### 8.8 RESISTANCE MEASUREMENT

#### Warning

**Risk of electric shock.**

**When measuring the impedance on the line, make sure that the circuit power is off and the capacitors on the circuit are fully discharged.**

1. Rotate the measurement function selection dial to the  $\Omega$  position and ensure that the power to the circuit under test is off.
2. Connect the black lead to the COM probe socket and the red lead to the INPUT probe socket.
3. The measured resistance value is read from the LCD

Note: When there is no input (e.g. open circuit), the display will show "OL" indicating that the measured value is out of range. If the measured resistance is greater than 1M $\Omega$ , it may take a few seconds for the meter to stabilize the reading. This is normal for high impedance measurements.

### 8.9 CONTINUITY / DIODE TEST

#### Warning

**Risk of electric shock.**

**Make sure the circuit power is off, and the circuit capacitors are completely discharged.**

1. Rotate the measuring function selector dial to the  continuity position and ensure that the power to the circuit under test is off.
2. Connect the lead to the COM input jack and red lead to the INPUT probe socket.
3. If the measured resistance of the line is less than 50 $\Omega$ , the buzzer will sound.

### 8.10 HOLDING READINGS

1. Press the "HOLD" button to hold the reading while taking a measurement, the value will be held on the display "H".
2. Press the "HOLD" button again to return to the normal reading function.

# 9. MAINTENANCE

---

## 9.1 REPLACEMENT BATTERY

### Warning

To avoid false readings that may result in electric shock or personal injury, replace the battery as soon as the “” symbol appears on the meter display.

To avoid electrical shock or personal injury, shut down and check to make sure that the test leads have been disconnected from the meter before opening the battery cover.

Follow these steps to replace the battery:

1. Turn off the instrument.
2. Remove all test leads from the input jacks.
3. Loosen the screws that secure the battery cover with a screwdriver.
4. Remove the battery cover.
5. Disconnect and remove the old battery
6. Replace with three new AAA batteries, pay attention to the battery positive and negative. Do not mix new with old batteries and do not use re-chargeable batteries.
7. Attach the battery cover and tighten the screw.

# 10. EXPLANATION OF SYMBOLS

## 10.1 EXPLANATION OF SYMBOLS



WEEE  
Do not dispose of Waste Electrical & Electronic Equipment in with domestic rubbish.



For indoor use.  
Do not expose to rain.



Class II construction  
(Double insulated).



Conforms to all relevant safety standards.



Earth.



Attention.



Back light.



Warning!  
Read instruction manuals before operating and servicing this equipment.



Diode test.



Low battery display.



Voltage AC.



Voltage DC.



Current AC.



Resistance in Ohms.



Continuity test buzzer.



Data hold / Screen lock.



Auto power off.



Inspection light  
Work light.



Clamp size.

# 11. DISPOSAL

---

## 11.1 DISPOSAL

- At the end of the machine's working life, or when it can no longer be repaired, ensure that it is disposed of according to national regulations.
- Contact your local authority for details of collection schemes in your area.

In all circumstances:

- Do not dispose of power tools with domestic waste.
- Do not incinerate.
- Do not abandon in the environment.
- Do not dispose of WEEE\* as unsorted municipal waste.



\* Waste Electrical & Electronic Equipment.



# NOTES

---



## CONTACT US

Draper Tools Limited, Hursley Road,  
Chandler's Ford, Eastleigh, Hampshire. SO53 1YF. U.K.

Helpline: +44 (0) 23 8049 4344

Sales Desk: +44 (0) 23 8049 4333

Internet: [www.drapertools.com](http://www.drapertools.com)

E-mail: [sales@drapertools.com](mailto:sales@drapertools.com)

General Enquiries: (023) 8026 6355

Service/Warranty Repair Agent:

For aftersales servicing or warranty repairs, please contact the  
Draper Tools Helpline for details of an agent in your local area.

YOUR DRAPER STOCKIST

©Published by Draper Tools Limited.

No part of this publication may be reproduced, stored in a retrieval system or transmitted in any form or by any means, electronic, mechanical photocopying, recording or otherwise without prior permission in writing from Draper Tools Ltd.