

VORNADO®

ENERGY
SMART

ENERGY SMART



MORE ENERGY EFFICIENT

Más eficiencia energética
Plus économe en énergie



MORE POWERFUL AIRFLOW

Flujo de aire más potente
Plus puissant flux d'air



PRECISE SPEED CONTROL

Control preciso de velocidad
Le contrôle précis de la vitesse

10 YEAR

SATISFACTION GUARANTEE

Satisfacción garantizada
Satisfaction garantie

MODELS 5303DC, 6303DC, 6803DC, 7503DC OWNER'S GUIDE

GUÍA DEL PROPIETARIO DE MODELOS 5303DC, 6303DC, 6803DC, 7503DC, GUIDE D'UTILISATION – MODÈLES 5303DC, 6303DC, 6803DC et 7503DC, 5303DC, 6303DC, 6803DC, 7503DC 모델 사용자 가이드, モデル 5303DC 6303DC 6803DC 7503DC 取扱説明書

CONTENTS

Important Instructions	2
Getting Started	6
Features	8
Controls.....	9
How To Use	11
Remote Control.....	12
Grill & Blade Removal	13
Cleaning	14
Troubleshooting	15

Español p. 16

Français p. 31

한국어 p. 46

日本語 p. 60



IMPORTANT INSTRUCTIONS

READ AND SAVE THESE INSTRUCTIONS

This owner's guide and any additional inserts are considered part of the product. They contain important information about safety, use and disposal. Before using the product, please familiarize yourself with all operating and safety instructions. Please keep all documents for future reference and pass these documents on, together with the product, to any future owner. Please refer to our website for the most current version of our owner's guide.

The following Warning messages are throughout this owner's guide:

DANGER

Indicates a hazard with a HIGH level of risk which, if not avoided, will result in death or serious injury. Please pay special attention to any instructions given to avoid this threateningly dangerous risk.

WARNING

Indicates a hazard with a MEDIUM level of risk which, if not avoided, could result in death, serious injury, minor or moderate injury or potential property damage.

IMPORTANT INSTRUCTIONS

Indicate additional information that will assist in the care of handling of the device.

INTENDED USE: This product is intended to circulate the air in indoor living spaces only. This product is not intended for commercial or industrial uses. The power supply (model 6803DC only) is for home appliances only.

The manufacturer assumes no responsibility for damage or injury caused by failure to follow these instructions, improper product use, or unauthorized product modification. Any such actions will invalidate the product warranty.

WARNING – When using electrical appliances, basic precautions should always be followed to reduce the risk of fire, electric shock and injury to persons, including the following:

WARNING

Risk From Unintended Use and Handling. Please take care to follow these guidelines to avoid risks to people or property:

- **Do Not** tamper with or modify this product in any way.
- **Do Not** use this product outdoors or directly exposed to weather.
- **Do Not** use this device in tropical humid climates. If the product is brought in from the cold to a warm area (e. g., during transport), condensation can occur within the unit. Let the device reach room temperature, before using it.
- **Do Not** use this product on wet surfaces. Do not use this product in a bathtub, shower or locate product where it may fall into a bathtub, laundry, swimming pool or other water container.
- **Do Not** immerse this product in water or allow water to drip into the motor housing.
- **Do Not** allow the power supply (model 6803DC only) or power cord

- to come in contact with water or wet locations.
- **Do Not** use this product near furnaces, fireplaces, stoves or other high-temperature heat sources.
- **Do Not** place the power supply (model 6803DC only) or power cord near heat sources, such as heaters or radiators.
- **Do Not** position this product too close to draperies or other loose fabrics as they may be drawn into the product, cutting off airflow and damaging the motor.
- **Do Not** carry this product by the cord, or use the cord as a handle as it can damage internal wiring. Do not unplug product by pulling on cord or place the cord under strain. To unplug, grasp the plug, not the power cord.
- **Do Not** run cord under carpeting. Do not cover cord with throw rugs, runners or similar coverings. Do not route cord under furniture or appliances. Arrange cord away from traffic area and where it will not be tripped over. To avoid a tripping hazard, safely coil/store the power cord.
- This unit requires one (1) lithium coin cell battery (CR2032), 3 Volt (included). **DO NOT DISPOSE OF BATTERIES IN FIRE. BATTERIES MAY EXPLODE OR LEAK.**

DANGER

Risk From Electrical Shock. Contact with wires or components that are under voltage could be potentially fatal:

- Use only the detachable external power supply and cord that comes with your product (model 6803DC only).
- **Do Not** touch the product with wet or damp hands.
- **Do Not** operate any product with a damaged cord or plug or after the product malfunctions, has been dropped or damaged in any manner. Discard product, or return to authorized service facility for

- examination and/or repair in order to avoid a hazard.
- The detachable external power supply and cord (model 6803DC only) have no user replaceable parts. If the power supply or cord is damaged, it must be replaced by the manufacturer or its service agent or a similarly qualified person in order to avoid a hazard.
- **Do Not** stretch the power cord or put the cord under strain.
- **Do not** insert or allow foreign objects to enter any input or output opening as they may cause risk of electric shock or fire or damage the product.
- Turn off all controls before unplugging. Unplug from wall outlet if not in use for extended periods of time.
- **Do Not** open motor housing. To avoid risk of shock, all service and/or repairs must be done by a Vornado Authorized Service Center. Only original replacement parts may be used.
- This appliance (US MODELS ONLY) has a polarized plug. (One blade is wider than the other.) To reduce the risk of electrical shock, this plug is intended to fit in a polarized outlet only one way. If the plug does not fit fully in the outlet, reverse the plug. If it still does not fit, contact a qualified electrician. **Do Not** attempt to defeat this safety feature.
- For safety reasons, always unplug the unit in the event of a thunderstorm.

WARNING

Risk From Improper Installation. Please take care to follow these guidelines to avoid risks to people or property:

- Ensure that wall power outlet is easily accessible so unit can be disconnected during an emergency.
- To reduce the risk of fire or electrical shock, do not use this product with any external (solid state) speed control device.

IMPORTANT INSTRUCTIONS

READ AND SAVE THESE INSTRUCTIONS

- To reduce the risk of fire or electric shock and injury to persons, do not use in a window.
- The plug portion of the adapter is used as a disconnect device. Therefore, the appliance should be placed near the socket outlet and easily accessible.

WARNING

Risk to Children and Other At-risk Groups of People:

- This appliance can be used by children ages 8 years and above and persons with reduced physical, sensory or mental capabilities or lack of experience and knowledge if they have been given supervision or instruction concerning use of the appliance in a safe way and understand the hazards involved.
- Children shall not play with the appliance.
- Cleaning and user maintenance shall not be conducted by children without supervision.
- This product and its packaging material are not toys and should be kept out of reach of children.

WARNING: KEEP NEW AND USED BATTERIES AWAY FROM CHILDREN. The remote control supplied with this product contains a button cell battery. Leaking or damaged batteries can cause burns on contact with skin. The battery could potentially be a choking hazard

for children. If the button cell battery is swallowed it can cause severe internal burns in just 2 hours and can lead to death. If you think the battery may have been swallowed or placed inside any part of the body seek immediate medical attention. In the US call the National Poison Control Center at 1-800-222-1222 or 202-625-3333. In Canada call 416-813-5900.

USA Models (5303DC, 6303DC, 7503DC Only)

This product employs overload protection (fuse). A blown fuse indicates an overload or short-circuit situation. If the fuse blows, unplug the product from the outlet. Replace the fuse as per the user servicing instructions (follow product marking for proper fuse rating) and check the product. If the replacement fuse blows, a short-circuit may be present and the product should be discarded or returned to an authorized service facility for examination and/or repair.

User Servicing Instructions

Grasp plug and remove from the receptacle or other outlet device. Do not unplug by pulling on cord. Open fuse cover (A.) by sliding access cover on top of attachment plug toward blades. Remove fuse carefully (B.) by gently prying out the ends of the fuse from the receptacle.

Risk of fire. Replace fuse only with 2.5 Amp, 125 Volt fuse. Contact Vornado customer service for replacement fuse. Phone: 1-800-234-0604 email: consumerservice@vornado.com

Install replacement fuse (C.) by first placing the end of the fuse into the fuse receptacle, which is opposite of the blades of the plug, then carefully push in the other end. Only push against the metal end of the fuse, not the glass center portion. Close the fuse access cover (D.) by sliding the cover back into the plug until it is completely closed,

latches and is flush with the face of the plug. **Risk of fire.** Do not replace attachment plug. Contains a safety device (fuse, AFCI, LCDI) that should not be removed. Discard product if the attachment plug is damaged.

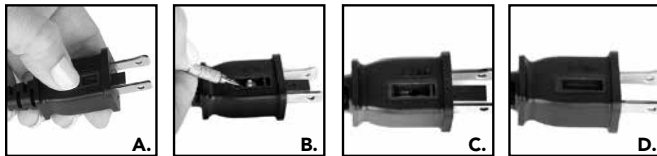

FCC WARNING: Changes or modifications to this unit not expressly approved by the party responsible for compliance could void the user's authority to operate the equipment.

This equipment may generate, use and/or radiate radio frequency energy that may cause harmful interference to radio communications. If this equipment does cause harmful interference to radio or television reception, which can be determined by turning the equipment off and on, the user is encouraged to contact your Authorized Service Center.



DISPOSAL

Dispose of all packaging materials in an environmentally responsible manner.

GETTING STARTED

Installing Circulator Head (Model 6803DC Only)

No tools required!

1. Gently place the circulator head face down on the ground on a soft cloth to avoid scratches or damages to the unit. Insert power cord into the top of pole (A) and pull through the bottom (B). Align the Lock Release Button (C) on circulator head with the hole (D) located on the pole. Push the pole onto the circulator head until the Lock Release Button snaps into place.

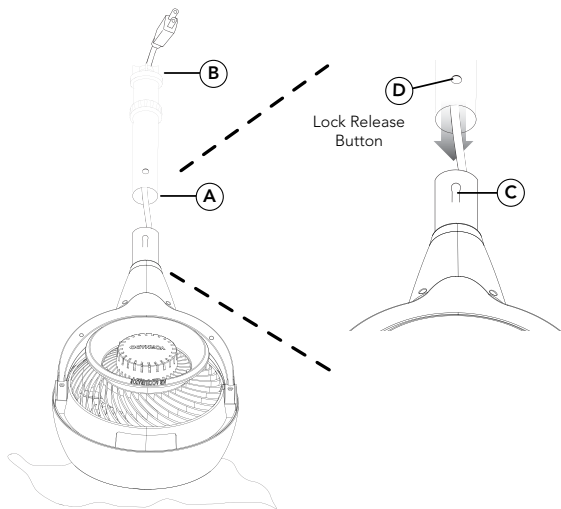

Stand Assembly (Model 6803DC Only)

1. The upper pole and lower pole are pre-assembled, with the fastening nut (E) secured on the underside of the base. Rotate fastening nut counter-clockwise to remove.
2. The legs are designed to fit into the grooves (F) on the underside of the base cap. Assemble all the legs onto the pole, then replace fastening nut by rotating clockwise to secure all the legs in place.

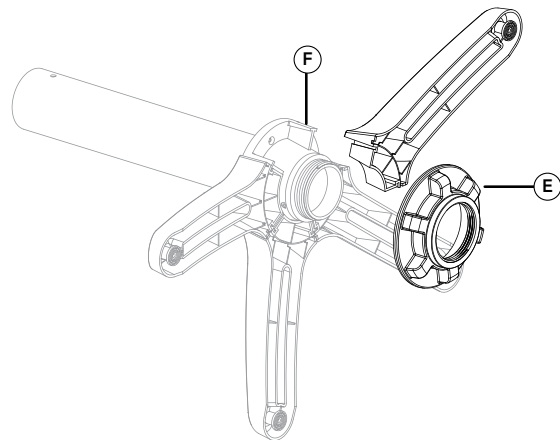

Cord Management

1. Wrap cord around Air Accelerator, located on back of unit. Secure cord with three clips (G) located at 2, 6 and 10 o'clock positions.

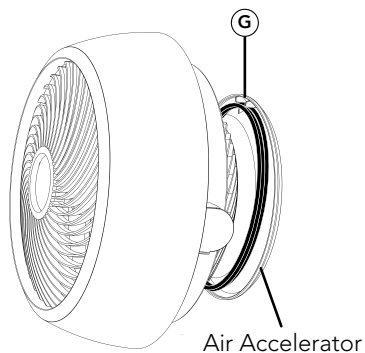

Adjusting Height (Model 6803DC Only)

1. Before adjusting the height of the circulator, support the circulator head with one hand. Use your other hand to loosen the height adjustment collar by gently rotating it counter-clockwise.
2. Slowly raise or lower the pole to the desired height and secure into position by rotating the adjustment collar clockwise until tight.

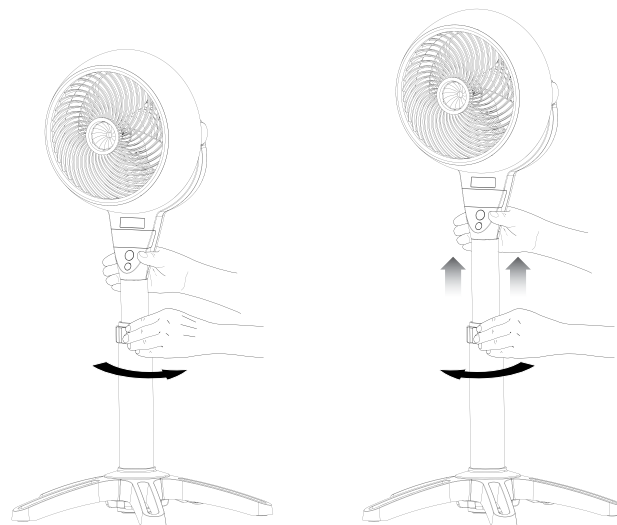

FEATURES

DIRECTABLE AIRFLOW

Direct the airflow where you want it.

ENERGY-SAVING TIMER

1-12 hour timer.

TOUCH-SENSITIVE CONTROLS (99 SPEEDS)

A speed setting for every comfort level.

REMOTE CONTROL

Convenience at your fingertips.

CORD MANAGEMENT

Integrated cord wrap.

FINGER FRIENDLY DESIGN

Resists curious fingers.

SILICON FEET

Non-marking feet added for stability.



CONTROLS

Model 5303DC, 6303DC, 7503DC Only



TIMER BUTTON 

POWER ON/OFF 

SPEED/TIMER
INDICATOR DISPLAY

SPEED/TIMER
ADJUSTMENT BUTTONS -/+

CONTROLS

Model 6803DC Only

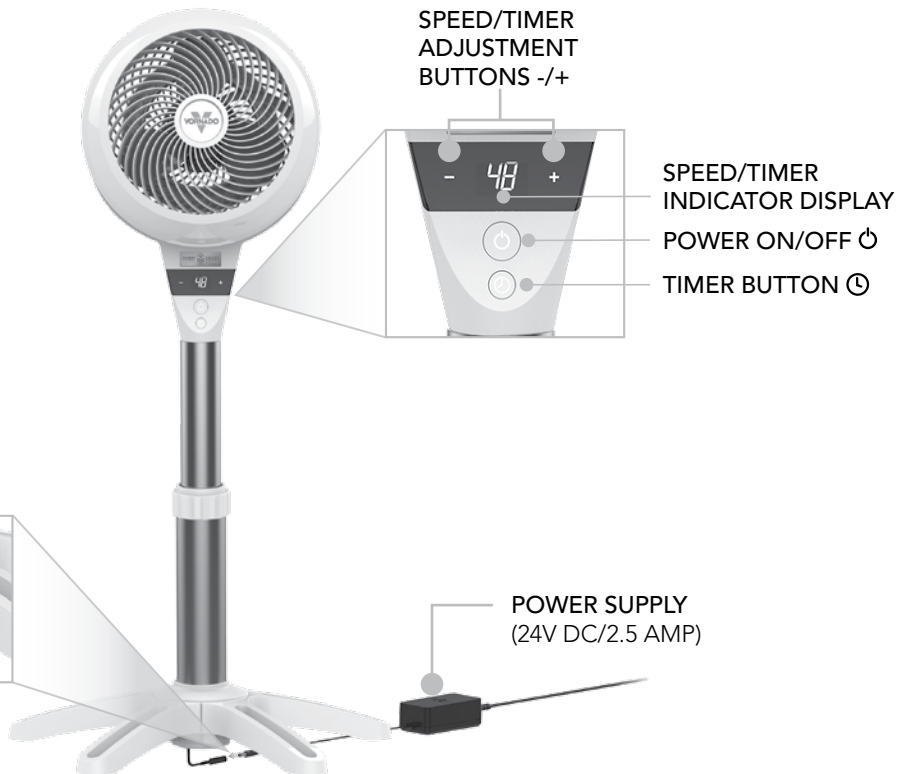

1. Insert DC power cord plug into port that extends from the bottom of circulator.
2. Connect the AC power cord to the power supply.
3. Plug the power cord into a power outlet.



HOW TO USE

1. Touch  to power on.

 **Tip** Your circulator returns to last saved memory setting.

2. Select desired speed by pressing **-/+**. Press and hold **-/+** to adjust speed up or down in 5 speed increments. Speed is indicated by number shown on Speed/Timer Indicator Display.
3. Press  to activate timer. The  illuminates and Speed/Timer Indicator Display flashes **0** to indicate Timer Adjustment Mode. While in this mode, select amount of time in one-hour intervals by pressing **-/+**. After three seconds, flashing stops and display shows hours to indicate timer is set. The display returns to the last speed selected. Touch  to quickly tell how many hours are remaining on the timer.



4. To adjust timer, repeat Step Three.
5. To cancel timer, repeat Step Three and set timer for **0**.

CORD MANAGEMENT

1. Wrap cord around Air Accelerator, located on back of unit. Secure cord with three clips located at 2, 6 and 10 o'clock positions.

REMOTE CONTROL

Screwdriver required. 

Your circulator remote includes (1) coin style 3V CR2032 battery. Battery comes pre-installed. Remove battery pull tab before first use.

1. For battery replacement, the remote requires one coin style 3V CR2032 battery. Always use the correct size and grade of battery for this product.
2. To replace battery, open battery door on the back side of the remote control (you will need to loosen the small screw on door using a #1 Phillips screwdriver). If necessary, clean the battery contacts and also those of the device prior to battery installation. Remove any plastic protection from the battery and place it in the remote with the + side facing out. Ensure the battery is installed correctly with regard to polarity. Replace the battery door and screw.

Note: Remove battery from the remote control when not in use for an extended period of time and always remove dead battery immediately and replace with fresh. Do not store dead battery in remote.

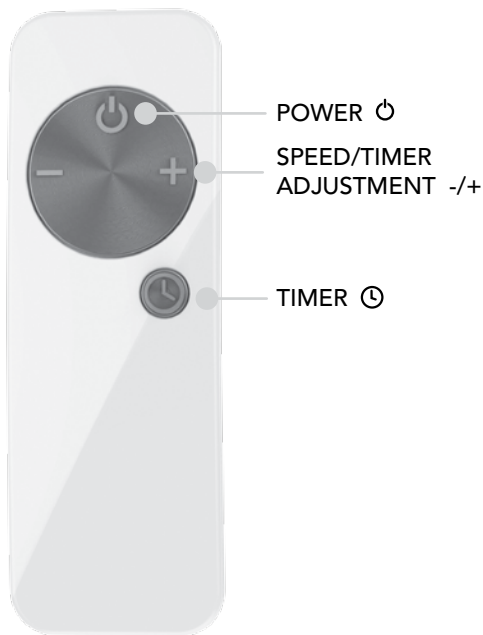

The remote control functions are the same as the control panel on the circulator.

The remote requires a line-of-sight path to allow for the signal to be received by the circulator. Point the remote control at the display panel for best reception.

GRILL & BLADE REMOVAL

WARNING: To reduce the risk of electrical shock and injury to persons, unplug the circulator before removing blade.

REMOVABLE GRILL

1. Using a phillips head screwdriver, remove grill by unscrewing the 4 screws located along the perimeter of the inlet grill at roughly 2, 5, 7, and 10 o'clock positions. This will release the grill. To reattach, position grill so the logo in the center of the grill is straight. Align the Locator Pin to reconnect grill. Once aligned replace screws.
2. Dust or wash with a mild dishwashing soap. Do not place grill in the dishwasher. The excessive heat can distort the plastic.

BLADE REMOVAL

1. It is possible to remove the blade should something accidentally get wrapped around the motor shaft. First, remove the nut from the shaft. Turn the nut **clockwise** to loosen. Pull the blade straight out from the shaft. When replacing, the blade can only go on the shaft one way. Be certain the flat side of the shaft aligns directly with the corresponding flat side on the blade's socket. Push the blade all the way on the shaft until it bottoms out. Do not use a hammer as this could result in bearing damage. Reinstall nut.
2. Wipe blade with a damp cloth. If your Air Circulator is used in a greasy environment, such as a kitchen, mild soap or a common household cleaner may be necessary. Do not use solvents.

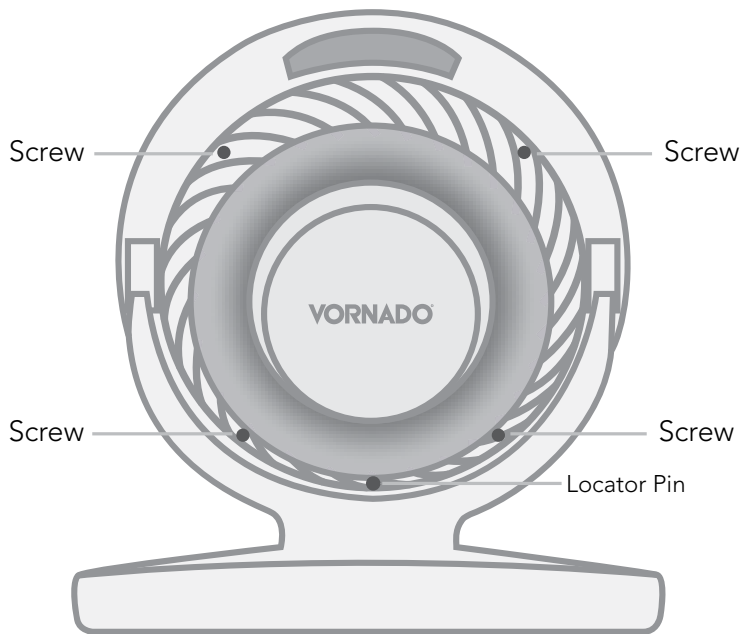

CLEANING

Because your product moves a substantial amount of air, it will need regular cleaning to remove lint, dust and grime. Never clean the product in any manner other than instructed in this owner's guide.



WARNING

Observe the following safety information to avoid risks and property damage.

- **Do** unplug your product before cleaning.
- **Do Not** use gasoline, thinners, solvents, ammonias or other chemicals for cleaning.
- **Do Not** attempt to repair or replace parts.



The motor is permanently lubricated and requires no oiling.

1. Dust or wipe the circulator with a damp cloth.
2. Use the brush attachment on your household vacuum cleaner to vacuum any accumulated dust.

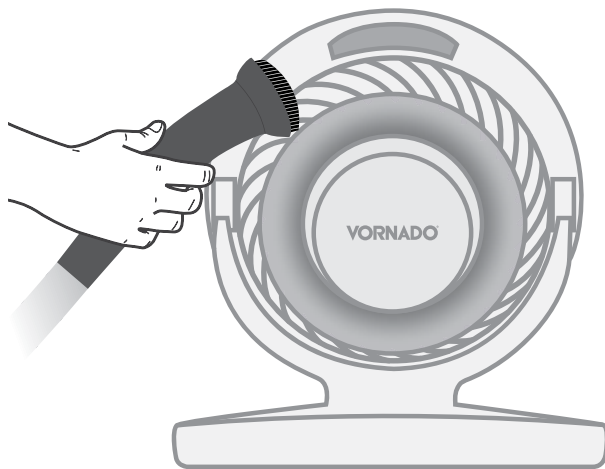

TROUBLESHOOTING

PROBLEM

POSSIBLE CAUSE AND SOLUTION

The unit fails to power on.

Unit is not plugged in. Plug Power Cord into electrical outlet. Model 6803DC Only - Ensure the AC power cord is plugged into the power supply and ensure DC power cord is plugged into the circulator.

Ensure unit fan speed setting is selected.

Plug fuse has blown (USA Models 5303DC, 6303DC, 7503DC Only). Replace fuse. See USER SERVICING INSTRUCTIONS on page 5.

Unit is damaged or in need of repair. Cease usage and unplug. Contact Consumer Service for assistance.

The outlet is worn or damaged. Try another outlet or contact a qualified electrician.

Airflow is weak or slow.

Unit set to a low speed setting. Adjust to a higher speed setting.

Airflow is blocked. Remove obstruction.

Adjust direction of airflow towards the user.

GFCI has tripped.

Under certain conditions, it is possible for a reset GFCI (Ground Fault Circuit Interrupter) outlet to trip when the user is changing speeds on a Vornado circulator. In this event, change to an outlet that is not connected to a GFCI device. It could also indicate a weak or defective GFCI outlet. Contact a qualified electrician to check the GFCI outlet.

Remote control is not working.

The battery is dead. Replace with (1) new 3 volt CR2032 battery. Refer to REMOTE CONTROL.

The remote requires a line-of-sight path to allow for the signal to be received by the unit. Position the unit so the receiver lens (located inside the display panel) is visible from the remote control.

10
YEAR

SATISFACTION
GUARANTEE

OUR WARRANTY

Vornado Air LLC (“Vornado”) warrants to the original consumer or purchaser this Vornado® Whole Room Circulator (“Product”) is free from defects in material or workmanship for a period of ten (10) years from the date of purchase. If any such defect is discovered within the warranty period, Vornado, at its discretion, will repair or replace the Product at no cost.

For warranty or repair service:

Call 1-800-234-0604 or email help@vornado.com to obtain a Return Authorization (“RA”) form. Please have or include your Product’s model number and serial number, as well as your name, address, city, state, zip code and phone number when contacting Vornado for warranty service.

After receiving the RA form, ship your Product to:

Vornado Air LLC Attn: Warranty & Repair 415 East 13th Street Andover, KS 67002. For your convenience, please have your model number and serial number when contacting Vornado with service inquiries. To assure proper handling, packages must be clearly marked with the RA number. Packages not clearly marked with the RA number may be refused at the receiving dock. Please allow 1-2 weeks for repair and return of your Product after the Product is received.

Repairs not covered by the warranty or outside the warranty period will require a fee to cover the cost of materials, labor, handling and shipping. This warranty does not apply to defects resulting from abuse of the Product, modification, alteration, repair or service of the Product by anyone other than Vornado, mishandling, improper maintenance, commercial use of the Product, damages which occur in shipment or are attributed to acts of God. REPAIR OR REPLACE-

MENT AS PROVIDED UNDER THIS WARRANTY IS THE EXCLUSIVE REMEDY OF THE CONSUMER. VORNADO SHALL NOT BE LIABLE FOR ANY INCIDENTAL OR CONSEQUENTIAL DAMAGES FOR BREACH OF ANY EXPRESS OR IMPLIED WARRANTY ON THIS PRODUCT. EXCEPT TO THE EXTENT PROHIBITED BY APPLICABLE LAW, ANY IMPLIED WARRANTY OF MERCHANTABILITY OR FITNESS FOR A PARTICULAR PURPOSE ON THIS PRODUCT IS LIMITED IN DURATION TO THE DURATION OF THIS WARRANTY. Some states do not allow the exclusion or limitation of incidental or consequential damages, or allow limitations on how long an implied warranty lasts, so the above limitations or exclusions may not apply to you. This warranty gives you specific legal rights, and you may have other rights that vary from state to state.

All company names and product names are trademarks of their respective owners. © All rights reserved. All technical information, data, and instructions for the installation, connection, and operation contained in these instructions for use correspond to the latest available information at time of printing. The contents of this manual may differ slightly from the actual product. Observe any additional supplements.

The manufacturer assumes no responsibility for damage caused by failure to follow these instructions or improper product use. Any such actions will invalidate the product warranty.

Any unauthorized product modification, repair by unauthorized repair center, or use of non-approved replacement parts is not recommended and any consequences will not be covered by support services or product warranties.



Designed, engineered and supported in Andover, KS

© 2016 Vornado Air LLC Andover, KS 67002 U.S. Patent Pending. Specifications subject to change without notice. Vornado® is a trademark owned by Vornado Air LLC.



we expect
this product
to be **PERFECT**

Esperamos que este producto sea perfecto
Si no lo es, ayúdenos a corregirlo

Nous exigeons de nos produits qu'ils soient parfaits
Si celui-ci ne l'est pas, nous corrigerons la situation

if it's not,
WE will make
it right

vornado.com

800-234-0604

help@vornado.com