

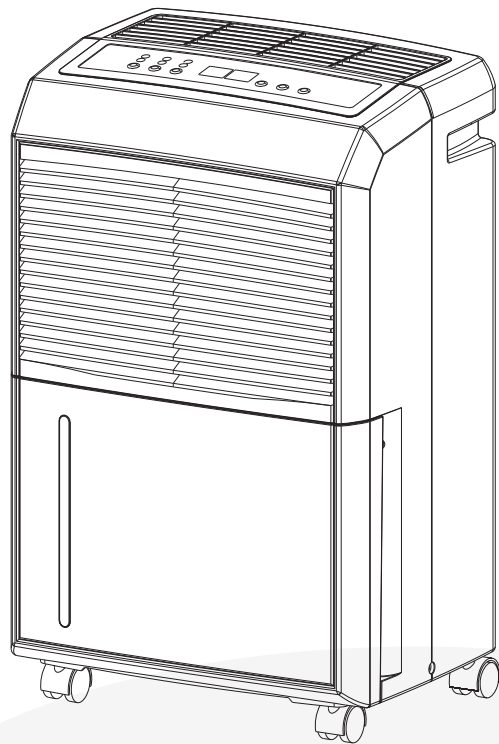

NEW WIDETECH

ausclimate
healthy indoor climate solutions
www.ausclimate.com.au

WDH-930EDH DEHUMIDIFIER



CONTENTS

WARNING / CAUTION	1
DESCRIPTION OF COMPONENTS	
FUNCTION EXPLANATION	2
OPERATING INSTRUCTIONS	
CASTOR INSTALLATION	3
CONTINUOUS DRAINAGE	4
CAUTIONS	5
MAINTENANCE / EMERGENCY	6
SPECIFICATION	LAST PAGE

USER'S MANUAL

VOLTAGE: 220-240V~50Hz

**THANK YOU FOR CHOOSING A NEW WIDETECH DEHUMIDIFIER.
BEFORE USE, PLEASE READ THE INSTRUCTION MANUAL CAREFULLY.
PROUDLY DISTRIBUTED BY AUSCLIMATE PTY LTD.**



WARNING

- Do not fold the power cord as shown below.

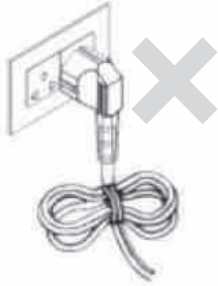

- Make sure the plug is placed fully & firm into the socket.

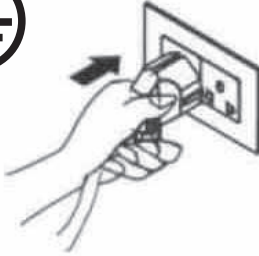

- Do not use multiple socket as shown below.

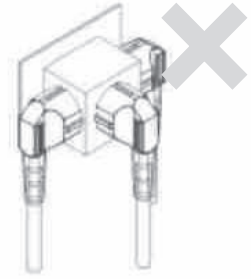

- Make sure the plug is clean.



- After turning the unit off, please take plug out of the socket.



- Do not have wet hands when connecting the power plug.



CAUTION

- Do not place anything on top of the control panel.

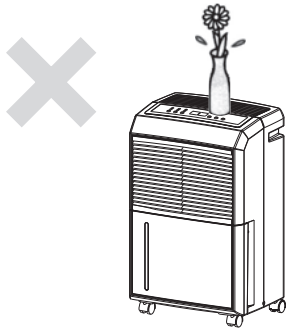

- Do not place anything over the inlet or outlet points.

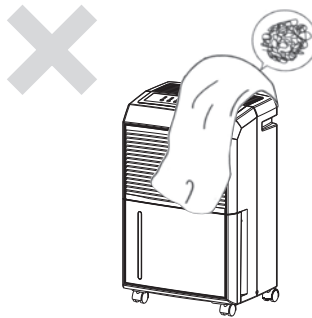

- Do not let children play with the unit or control.

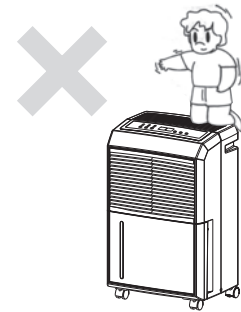

- Do not wet the machine or the control panel.

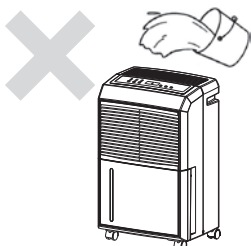

- Keep the flammable gas/oil away from the machine.



- Ask professionals to do the servicing.

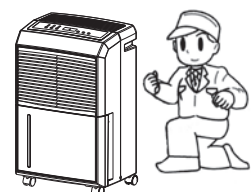

DESCRIPTION OF COMPONENTS

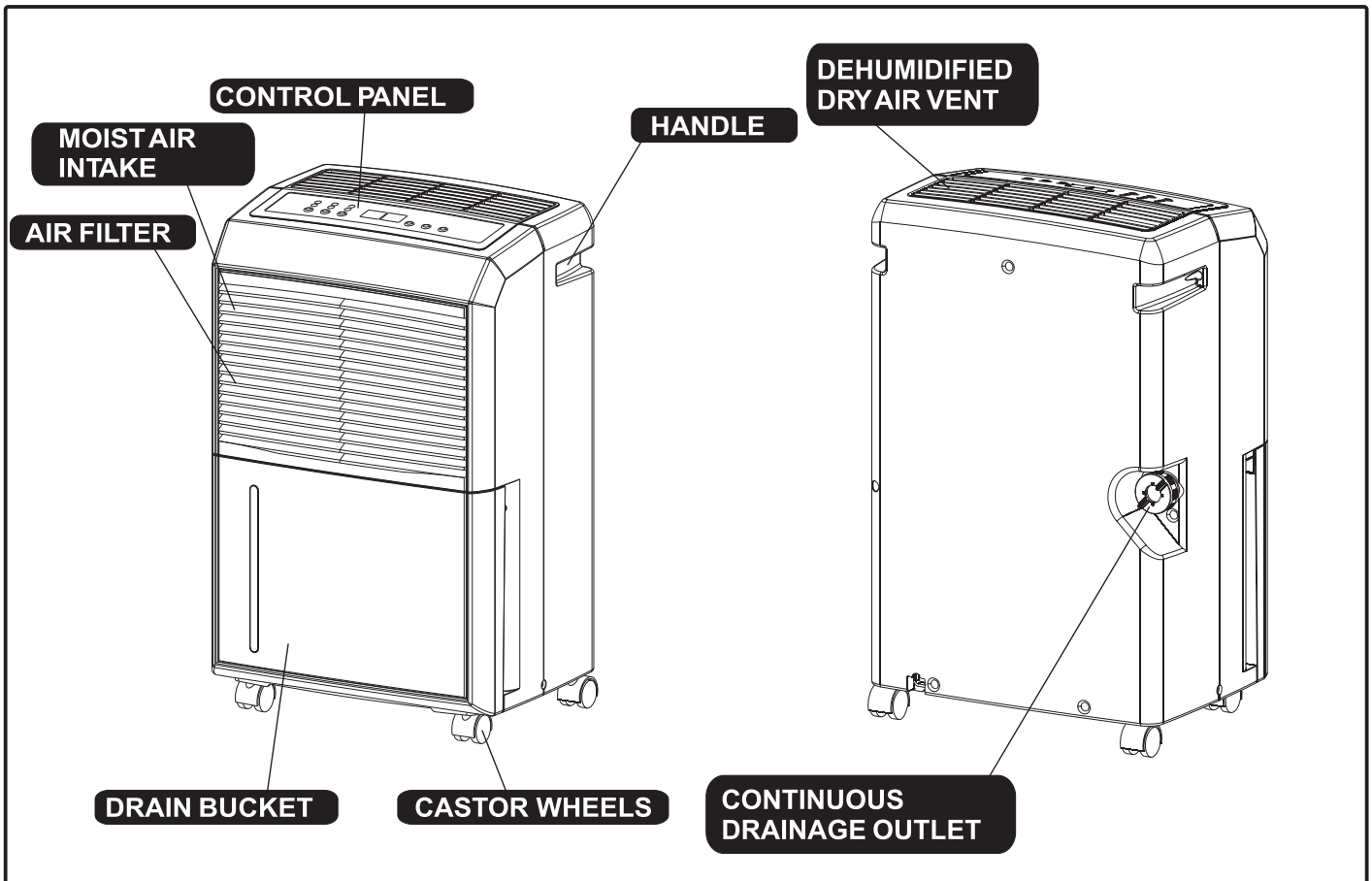

FUNCTION EXPLANATION

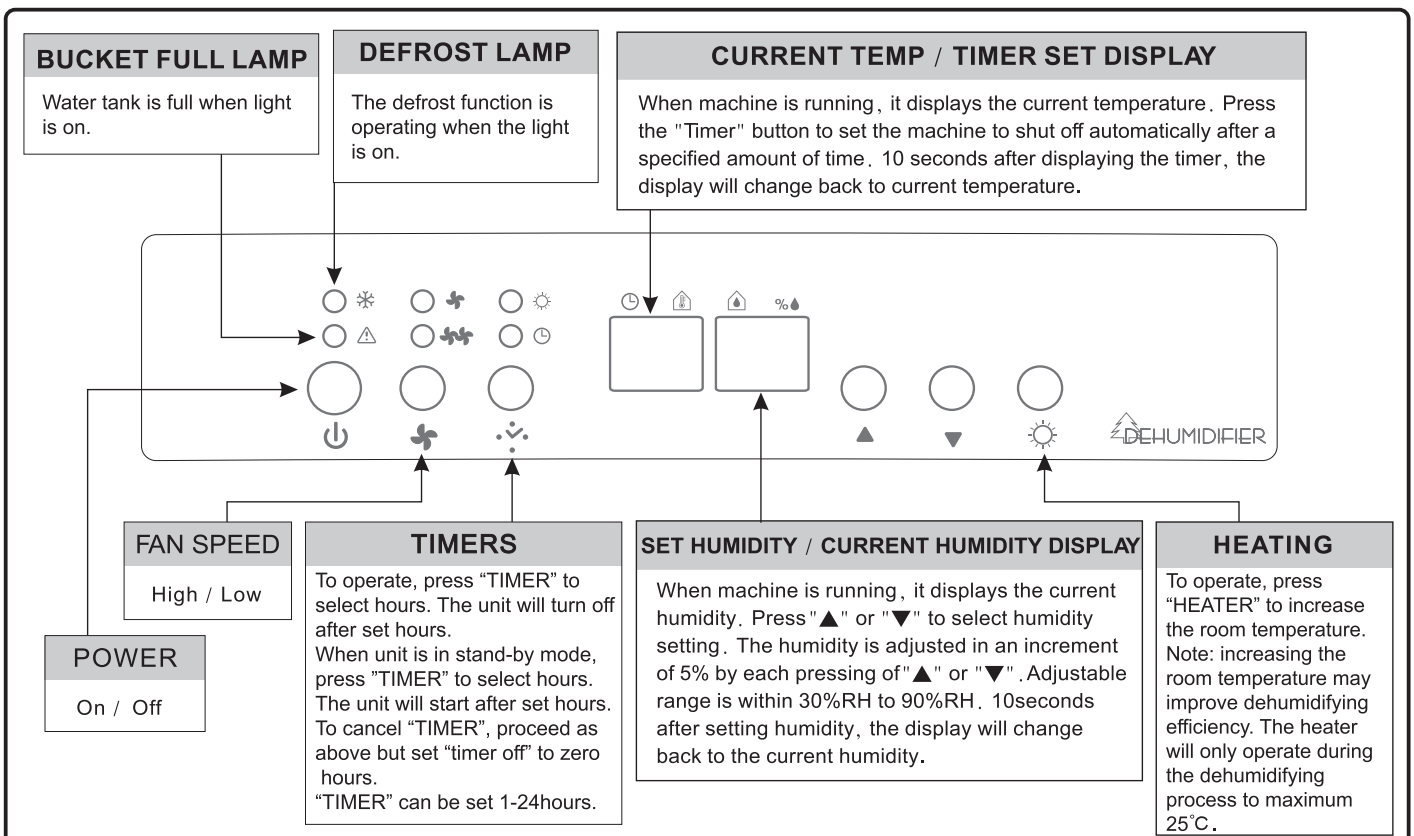

OPERATING INSTRUCTIONS

● Start Operation

- 1) Place the product dehumidifier in an upright position on a flat, stable, heat resistant surface. Make sure there is nothing flammable or heat sensitive within 100 cm.
- 2) Insert the dehumidifier's power plug into a suitable wall socket with electricity supply the same voltage depicted on the unit's rear rating label.
- 3) Ensure the water tank is inserted correctly into the body of the dehumidifier.
Note: if the "Bucket Full" light illuminates when turning it on for the first time, just pull out the water tank, check that the "Float" lever moves freely, then return the water tank into the correct inserted position.

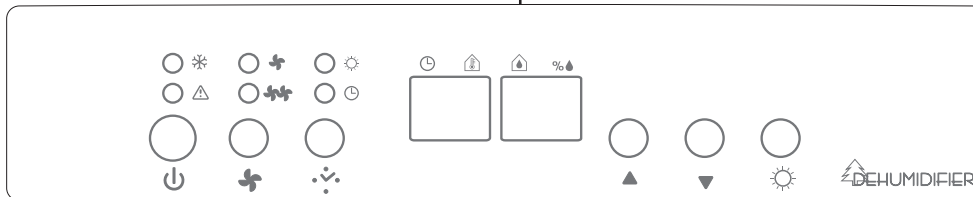
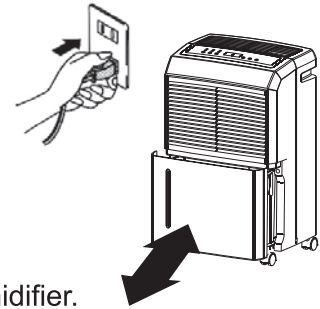

● When Bucket Full Lamp Is On

When the water tank is full the machine will stop and the "Bucket Full" light will illuminate. The water tank should be carefully removed from the machine by sliding it outwards from the front of the machine and it should be emptied. When the empty tank is replaced properly into the machine, the machine will start up and run normally.

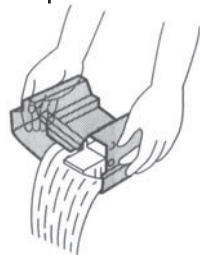

Please use both hands to carefully empty the water tank.

● DEFROST

When operating in low temperatures the surface of the dehumidifier's coil/evaporator may accumulate frost/ice and affect the efficiency of the dehumidifier. When this happens the machine will go into periodic defrost mode automatically. This is quite normal.

The "Defrost" lamp ✱ will come on, the compressor will cease operating and the fan will continue to operate until the frost/ice has thawed. As soon as the frost/ice has melted, the compressor will restart and continue the dehumidifying process. Defrost time will vary depending on room temperature and humidity.

The dehumidifier should not be used below 5°C. If the dehumidifier freezes up, turn the machine off for a few hours before restarting.

CASTOR INSTALLATION

Castor wheel installation is recommended to avoid damage to floors.

1. Remove the castor wheels from the water tank/bucket of the dehumidifier.
2. Position the dehumidifier on its side.
3. Locate the arrow on the bottom of the dehumidifier and insert a castor wheel according to the arrow direction.
4. Slide the castor wheel in as far as it will go. It will click into place.
5. Repeat steps 3-4 for the other castor wheels.

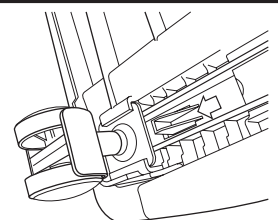

CONTINUOUS DRAINAGE

The continuous drainage function can be started in the following steps when there is suitable conditions for drainage near the dehumidifier.

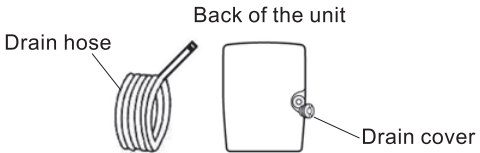
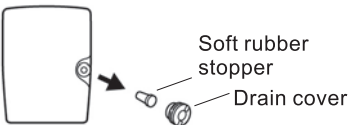
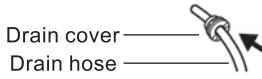
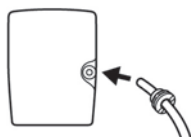
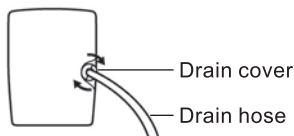
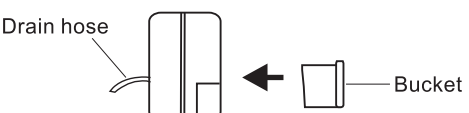
<p>1. To save having to periodically empty the water tank, this unit can be configured for continuous drainage. You can use the supplied drain hose to connect to the continuous drainage connector.</p>	 <p>Back of the unit Drain hose Drain cover</p>
<p>2. Unscrew and remove the drain cover at the rear of the unit. 3. Remove the soft rubber stopper. Put it into the water tank for safe keeping.</p>	 <p>Soft rubber stopper Drain cover</p>
<p>4. Insert the drain hose through the hole of the drain cover.</p>	 <p>Drain cover Drain hose</p>
<p>5. Connect the drain hose to the drain port.</p>	
<p>6. Tighten the drain cover in clockwise direction onto the rear of the unit.</p>	 <p>Drain cover Drain hose</p>
<p>7. Place the bucket on its original location.</p>	 <p>Drain hose Bucket</p>

INSTALLING DRAINAGE PVC HOSE

When using the continuous drainage function, the PVC hose must be placed horizontally below the level of the drainage hole. Avoid uneven floor surface and kinking the drainage hose.

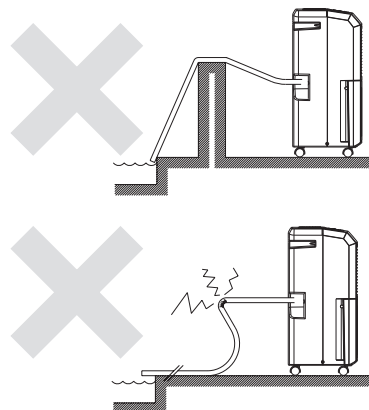
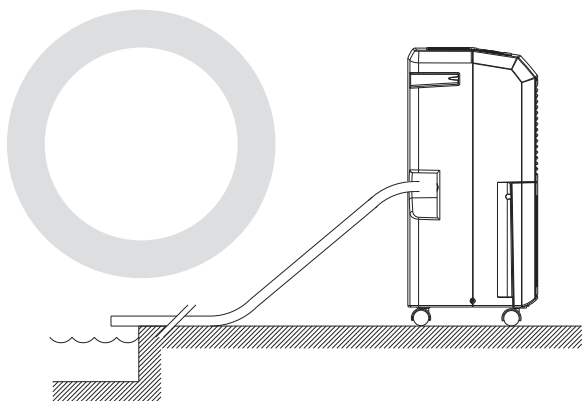

CAUTIONS

- Do not pull the power cord to avoid breaking it and creating danger.

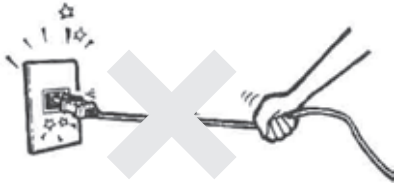

- Do not use insect, oil or paint spray around the machine, it might cause damage to the plastic parts or start a fire.

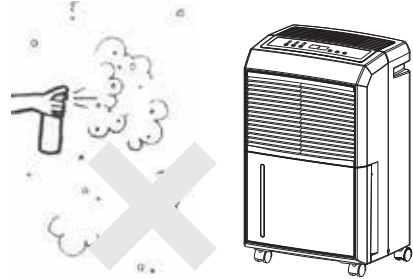

- Do not place the machine on uneven surface to avoid vibration, excessive noise and possible water leakage.

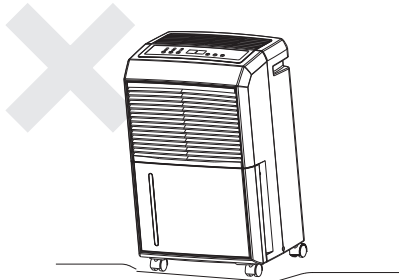

- Always keep the unit 20 cm away from the wall to dissipate the heat properly.

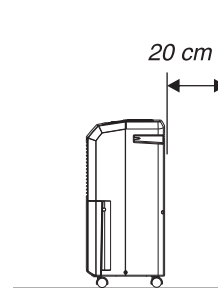

- It is dangerous to put anything into the machine.

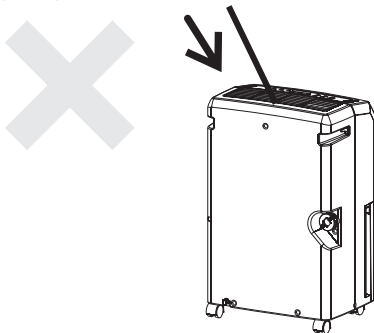

- Close all the open windows to reach the maximum possible efficiency of removing moisture.

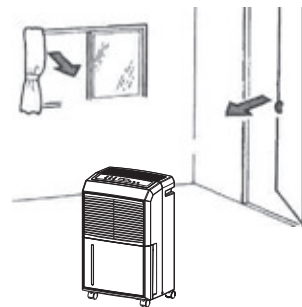

- Keep the machine away from any type of heat sources.

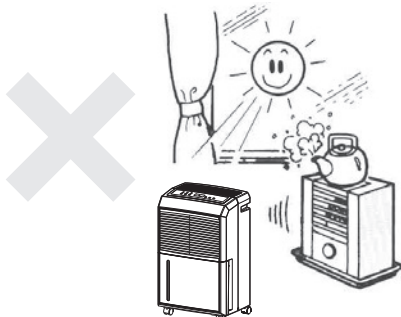

- Lift, carry and move the dehumidifier in an upright position and avoid any excessive shaking.

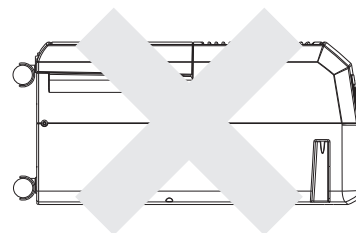

MAINTENANCE

For safety reasons, make sure the dehumidifier is unplugged before servicing or cleaning the machine.

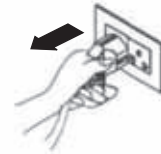

1) Cleaning the shell

- A. Wipe the shell with a clean, soft cloth.
- B. If the dehumidifier is very dirty, use mild detergent then wipe off the detergent with semi dried cloth.
- C. Do not wash the machine with a hose or immerse it in water.

2) Cleaning the air filter

The air filter filtrates the dust and impurities in the air. For optimum dehumidifying efficiency clean the air filter every two weeks or as required.

● Cleaning Steps :

- A. Pull the air filter out gently.

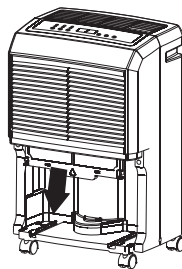

- B. Clean the filter with a vacuum cleaner or wash it with clean water and dry with a dry cloth.

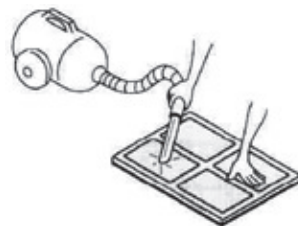

- C. Put the clean air filter back in place and continue to operate the dehumidifier.

EMERGENCY

If a problem occurs, switch off and unplug the unit immediately. For all troubleshooting please contact Ausclimate (www.ausclimate.com.au) and for your own safety do not disassemble the dehumidifier.

SPECIFICATION

MODEL	WDH-930EDH
POWER	220-240V~ 50Hz
MOISTURE REMOVAL	20 L/D (27°C 60%RH) 35 L/D (30°C 80%RH)
POWER INPUT	520W/1100W(Heating)
SIZE OF SHELL (W*H*D)	340*545*250 mm
WEIGHT	13.8 kg
OPERATING TEMPERATURE	5°C~32°C

(EU) No. 517/2014:

Do not vent R-410A into atmosphere: R-410A is a fluorinated greenhouse gas, covered by Kyoto Protocol, with a Global Warming Potential (GWP) = 2088.

- If the power cord on this unit is damaged it must be replaced by the manufacturer, its service agent or qualified persons in order to avoid a hazard.
- This appliance is not intended for use by children or other persons without assistance or supervision if their physical, sensory or mental capabilities prevent them from using it safely. Children should be supervised to ensure that they do not play with the appliance.

Waste electrical products should not be disposed of with household waste. Please recycle where facilities exist. Check with your local authority or retailer for recycling advice.



Proudly distributed by Ausclimate Pty Ltd

For all enquiries and contact details please visit our website:

healthy indoor climate solutions
www.ausclimate.com.au