



Manuale d' istruzioni

Owner's Guide

Manuel d'instructions

Bedienungsanleitung

Instrucciones para el uso

Manual de instruções

Gebruiksaanwijzing

Инструкция по применению

Návod k použití

Manual de instrucțiuni

Käyttöohjeet

المالك دليل

ΟΔΗΓΙΕΣ ΧΡΗΣΗΣ

Bruksanvisning

Brugsanvisning

Przewodnik użytkownika

diva
BUGATTI®

BUGATTI®

Vita
Una vera
Vediva
Vola

BUGATTI®

Vera
bollitore/
kettle/bouilloire/
Wasserkocher



Vita
spremiagrumi/juicer/
presse-agrumes/
Saftpresse



Uma
bilancia/
scales/balance/
Küchenwaage

Vela
frullatore/
blender/mixer



Volo
toastapane/toaster/
grille-pain

diVa
macchina per il caffè/coffee
machine/machine à café/
Espressomaschine



diva

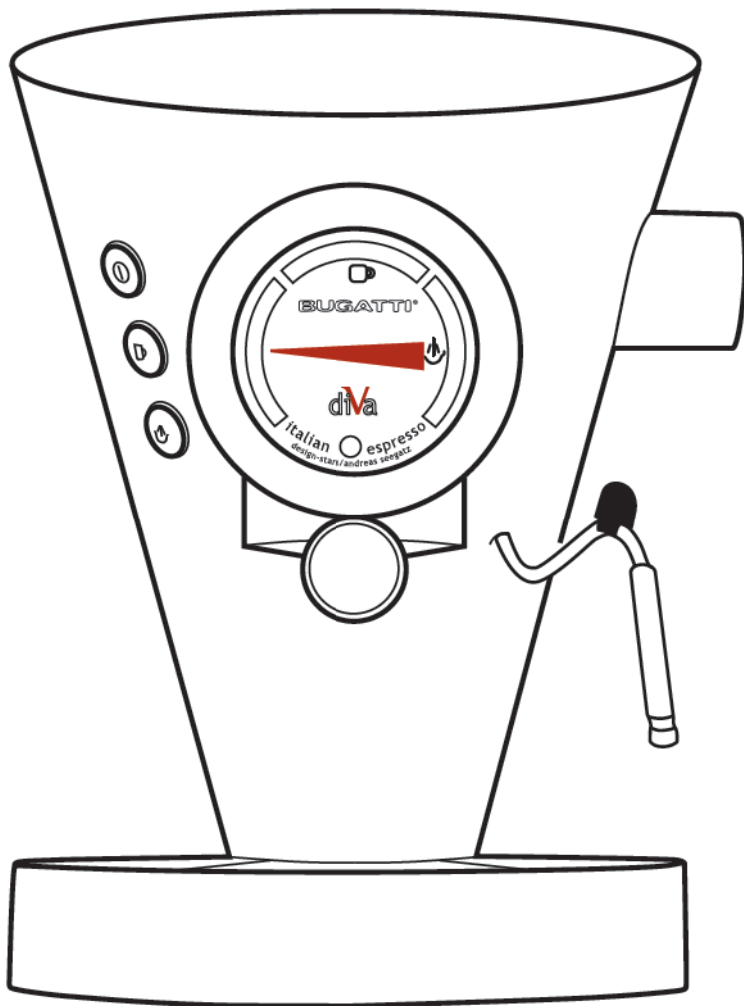



diVa

Gusta il caffè esclusivo Bugatti appositamente preparato per la diVa.
Enjoy your exclusive Bugatti coffee especially prepared for diVa.
Savourez le café que Bugatti a préparé exclusivement pour la diVa.
Genießen Sie den exklusiven Espresso Bugatti, der speziell für die diVa zubereitet wird.
Guste el exclusivo café Bugatti especialmente preparado para diVa.
Saboreie o café Bugatti preparado exclusivamente para a diVa.
Geniet van een exclusieve BUGATTI koffie speciaal bereid voor diVa.
Попробуй исключительный кофе Bugatti приготовил для DiVa
Pochutnejte si na exkluzivní káve Bugatti, speciálně připravené pro kávovar DiVa.
Gustați exclusiva cafea Bugatti special pregătită cu DiVa.
Maista Bugatti exclusive kahvia, joka on valmistettu erityisesti diValle.
بديفا خصيصا المعدة "بجاتي" بقهوتك تمتع
享受專為 diVa 提供的布加蒂咖啡
diva のために作られたブガッティ・コーヒーをお楽しみください。
Nyd den eksklusive bugatti kaffe, specielt lavet til diva

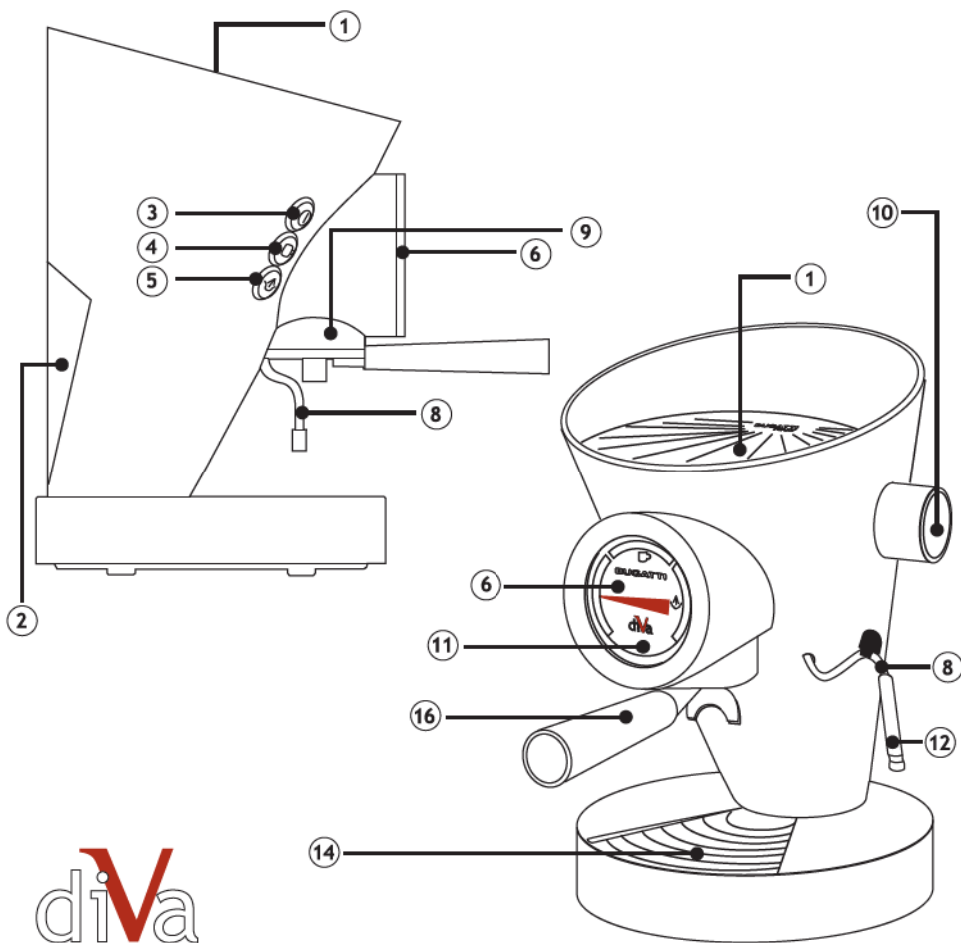



diva

 BUGATTI®

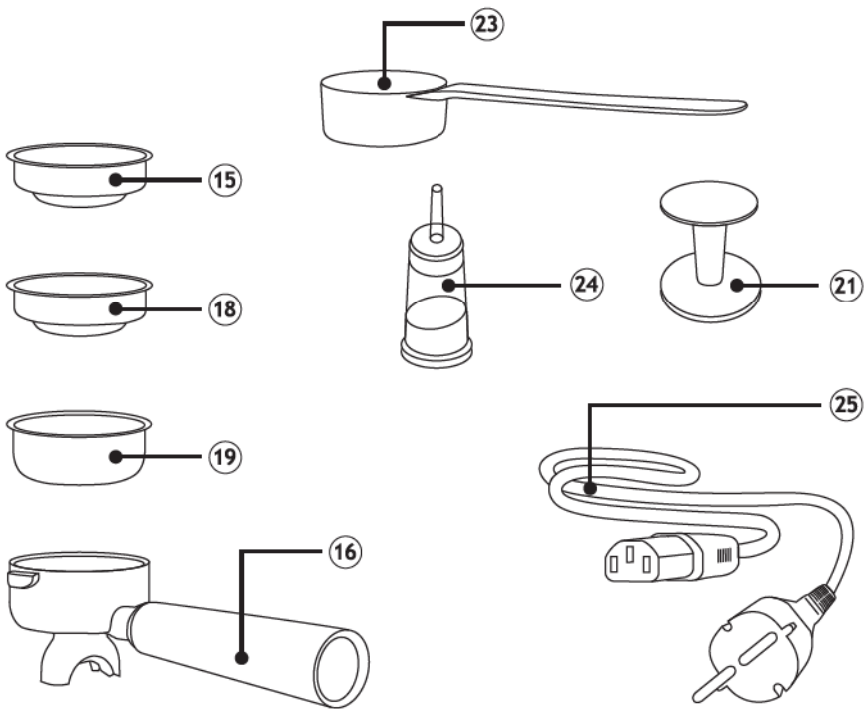



IMPORTANT NOTICES

Dear Customer,

Diva, the coffee machine, enables you to make espresso and normal coffee using either pods or ground coffee. Like all domestic appliances, this coffee-making machine must be used with care and attention to prevent accidental burns and prevent damage to the machine.

BEFORE STARTING UP THE MACHINE, CAREFULLY READ ALL THE INSTALLATION INSTRUCTIONS, USE AND MAINTENANCE AND THE SAFETY NOTICES. Do not use the machine unless you are thoroughly familiar with the instructions.

WARNING

No liability is accepted for damage due to:

- incorrect use or use other than for its intended purpose
- repairs carried out by unauthorized staff
- use of non-original spare parts or accessories

Instructions for use

For further information, or in case of problems that have not been sufficiently addressed in the present instructions, contact Customer Care at CASA BUGATTI .

SAVE THESE INSTRUCTIONS for use and remember to pass them on to those who will use the machine after you. If the instructions are lost before you use the machine, request the instruction booklet from Customer Care at CASA BUGATTI or send an e-mail to diva@casabugatti.it.

On the first page you will find the illustrations relating to the text. Keep the first page open as you read the instructions for use.

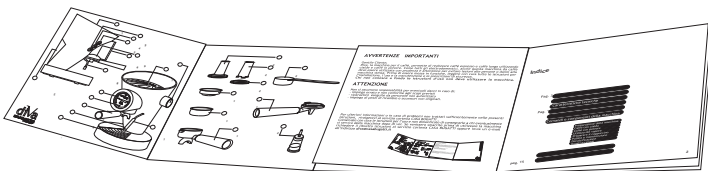

Contents

Page 19	Technical features
Page "	Machine controls and parts
Page "	Accessories
Page 20/21	Important safeguards
Page 22	Installation and starting up
Page 23/29	Advice and recommendations on use

Page 23	Setting up the machine
Page "	Coffee with pods
Page 24/25	Ground coffee
Page 26	Using steam
Page 27/28	Preparing cappuccino
Page 29	Cleaning and maintenance
Page 30	Descaling
Page 30/31	Troubleshooting

Page 28	The best espresso coffee
Page 32	Warranty

Technical features

Power supply	See rating plate underneath machine
Power rating	See rating plate underneath machine
Dimensions	Diameter approximately 240 x h. 365 mm
Solid cast	Solid cast aluminium and stainless steel 18/10
Weight	About 6,5 Kg
Length of power supply cable	Approximately 1.2 metres
Pump	15 bar, electrico-vibrating
Boiler capacity	Approximately 0,25 litres
Temperature control	Mechanical thermometer with Bourdon coil with analogue reading
Quantity programming	Manual
Steam delivery	Manual
Tank capacity	Approximately 0,8 litres
Heating up time	Approximately 3 minutes
Thermal overload protection	Built in
Insulation	Protection class I
Approvals	See rating plate underneath machine
Conformity	CE - 89/336 CEE - cCSAus-cUL
Warranty	As per attached warranty information

Machine controls and parts

Surface for warming cups	①	Steam nozzle	⑧
Water tank	②	Brewing unit	⑨
On - off switch	③	Steam knob	⑩
Coffee delivery switch	④	Power-ON light	⑪
Steam switch	⑤	Removable steam nozzle protection	⑫
Thermometer	⑥	Drip grid	⑭
Filter-holder unit	⑬		

Accessories

Filter for pods	⑮	Pressing tool for powder coffee	⑳
Filter-holder unit for powder coffee and pods	⑯	Dosing spoon	㉑
Filter for 1-cup dose	⑰	Ion exchange filter for filtering calcareous water	㉒
Filter for 2-cup dose	⑱	Electrical wire with plugs	㉓

IMPORTANT SAFEGUARDS

CAREFULLY READ ALL INSTRUCTIONS. THE APPLIANCE MUST BE USED ONLY BY ADULTS WHO HAVE BEEN TRAINED IN ITS USE.

1. To protect against fire, electric shock and injury to person **DO NOT IMMERSE PARTIALLY OR TOTALLY ANY PART OF THE CORD, PLUGS, OR THE MACHINE ITSELF IN WATER OR IN OTHER LIQUID. CAUTION: HOT SURFACES, DANGER OF BURNS.** Do not touch hot surfaces. Use handles or knobs. Be very careful when touching very hot parts such as the hot water/steam pipe (use a protective glove): **DANGER OF BURNS!** Steam and hot water can cause burns. Never direct the jet of steam or hot water towards parts of the body.

2. **HOUSEHOLD USE ONLY.** Do not use appliance for other than intended use. Do not make any technical modifications as these may cause risks and will void the warranty.

3. Close supervision is necessary when any appliance is used near children. The appliance is not to be used by children or persons with reduced physical, sensory or mental capabilities, or lack of experience and knowledge, unless they have been given supervision or instruction. The kettle must be used only by adults who know how to use it in accordance with these instructions.

4. Never touch live electrical parts. They may cause electric shocks and serious injuries. Connect the machine to a wall socket having the appropriate voltage. The voltage must correspond to that indicated on the rating plate underneath the machine. **Make sure that the socket you are using is earthed (grounded).** 

5. **Figure A:** electrical wire. A short detachable power-supply cord is provided to reduce risks resulting from becoming entangled in or tripping over a longer cord. We do not suggest using an extension cord.

c) Do not place on or near a hot gas or electric burner or in a heated oven.

d) Do not use outdoors. Do not let cord hang over edge of table or counter, or touch hot surfaces. Do not operate any appliance with a damaged cord or plug or after the appliance malfunctions, or has been damaged in any manner. Return appliance to the nearest authorized service facility for examination, repair or adjustment. The use of accessory attachments is not recommended by the appliance manufacturer as they may result in fire, electric shock or injury to the user.

IMPORTANT SAFEGUARDS

6. Figure B: Make sure that children cannot play with the machine. Children should not use, operate or play near the appliance. The machine must be positioned so that the cups warming surface on the top (1) is at a minimum height of 1.20 meters above the floor.

7. Place the machine on a flat surface, making sure that the suction feet adhere firmly to the support surface so that the machine cannot be overturned. Hot water or steam may escape: danger of burns! Do not use the machine in environments below 5 °C. Do not place the machine on very hot surfaces or near open flames.

8. Figure C: Do not direct the jet of steam or hot water towards parts of the body. Be very careful when touching very hot parts such as the hot water/steam pipe (use a protective glove).

9. Figure D: To ensure that the machine works correctly, place it on a level surface in an adequately lighted and hygienic environment with an easily accessible electrical socket. Keep the machine at least 100 mm (4 inches) away from the walls.

10. Figure E: Unplug from outlet when not in use and before cleaning. Allow to cool before putting on or taking off parts, and before cleaning the appliance. The appliance must be cleaned with a freshly dampened non-abrasive cloth soaked with a few drops of neutral non-corrosive detergent (never use solvents).

11. In the event of faults, defects or suspected faults after a fall, immediately unplug from the socket. Never start up damaged appliances. The repairs must be carried out by the Service Centre of CASA BUGATTI. Contact your dealer and/or contact Customer Care at CASA BUGATTI or send an e-mail to diva@casabugatti.it. In the event of fire, use carbon-dioxide (CO₂) extinguishers. Do not use water or powder extinguishers.

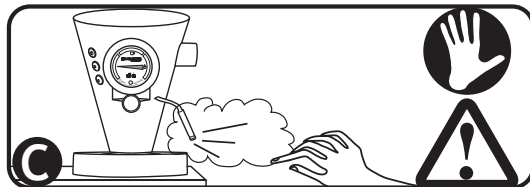
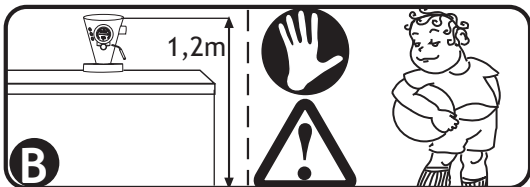
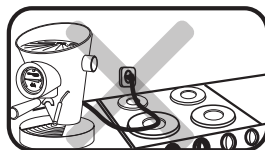
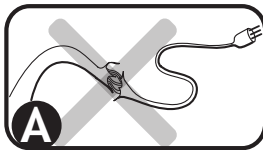

Installation and starting up

The original packaging has been designed for dispatch by post. Keep it in case you need to return the machine to the supplier. Before installing the machine, comply with the important safeguards indicated on page 20, 21.

Connecting to power supply. Always attach plug to appliance first, then plug cord into the wall outlet. To disconnect, turn all controls OFF, then remove plug from wall outlet. Be aware electric power can kill. Strictly comply with safety regulations.

The coffee machine must be connected, with the Casa Bugatti original electrical wire (25) to a wall socket with a voltage as specified on the rating plate underneath the machine. Make sure that the socket you are using is earthed (grounded).



Never use faulty or damaged power cords.

We do not recommend using an extension cord with the appliance. This may damage the appliance and void the warranty.

Never allow live parts to come into contact with water: may cause short circuit!!! Steam and hot water can cause burns. Never direct the jet of steam or hot water towards parts of the body. Handle the steam/hot water pipe with care: risk of burns (use a protective glove)!

Do not start up the machine without first filling the tank with water. Take care to insert it carefully in its seat.

1) When starting up the machine, push the switch (3) to light up the light (11) on the thermometer, which will show that the machine is on and that the heater resistance is heating up.

2) Then open the tap (10) of the steam nozzle and press the coffee delivery switch (4) to facilitate pump priming. Pump priming has occurred when water comes out of the steam nozzle.

3) Shut the steam tap (10) and keep the coffee-delivery switch (4) pressed until water flows out from the brewing unit (9).

4) Turn off the coffee delivery switch 4 : the operation has finished.

5) Always make sure that there is water in the tank (2) and that the suction pipe is correctly inserted. **Warning:** the pump will be irreparably damaged if the machine operates without water even for a short period.

6) Every time you add water into the tank (2), remember to empty the waste water tank located under the drip grid (14).

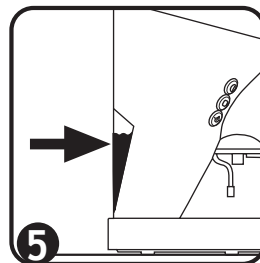
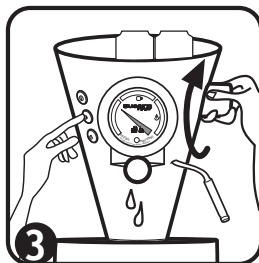
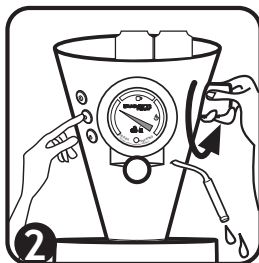
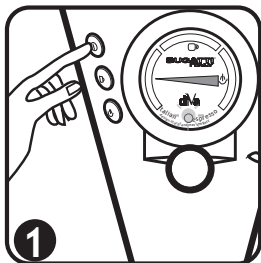

Advice and recommendations for use

Setting up the machine.

The first time that DiVA is used or if it is used after a long period of inactivity:

- 1) Fill the tank (2) with cold water.
- 2) Connect the appliance to a wall socket in strict compliance with the important safeguards specified on page 20, 21.
- 3) Switch on the machine by means of the switch (3); the red light on the thermometer will light up (11)
- 4) Load the water system: open the steam tap by turning the knob (10) counterclockwise and then press the coffee-delivery switch (4). When water leaves the steam nozzle (8) shut the tap by turning the steam knob (10) clockwise. Wait for a few minutes so that water runs out of the brewing unit (9) and then stop water flowing out by using the coffee-delivery switch (4) to switch off the pump.
- 5) Wait for the hand of the thermometer (6) to reach position in the range shown by the coffee cup symbol on the thermometer (6) dial.
- 6) The machine is ready for use.

DiVa is provided with one filter-holder unit (16) with a filter for ESE pods (15), one filter for ground coffee for 1 cup (18) and one filter for ground coffee for 2 cups (19)

Coffee with pods.

- 1) Make sure that the thermometer hand is in the position of the coffee cup symbol.
- 2) Place the filter (18) in the filter-holder unit (16) to pour one cup of coffee and place a pod in it, taking care to place it perfectly in its seat.
- 3) Insert the filter-holder unit (16) into the seat of the brewing unit (9) and fix it by rotating the handle to the right to about the centre of the machine (handle must be rotated until correct pressure for a seal during delivery is reached).
- 4) Take one dry and warm coffee cups from the cup-warming surface and place them under the spout of the filter holder.

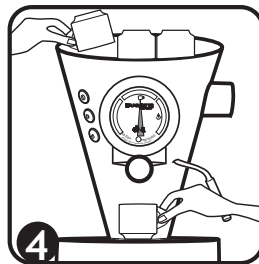
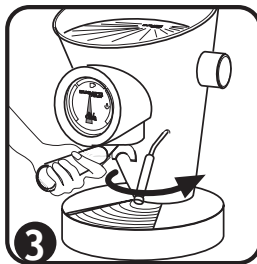
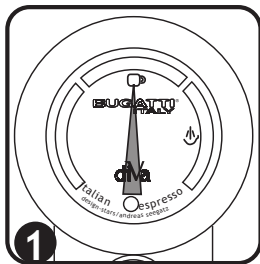

- 5) Press the button (4) to start delivery of the coffee.
- 6) Then press the button (4) again to stop delivery of the coffee: you can decide what type of coffee to enjoy: "ristretto", "espresso", "lungo" or ...
- 7) Serve the coffee immediately to fully enjoy its aroma.
- 8) Remove the filter-holder unit (16) from the brewing unit (9) by turning the handle to the left.
- 9) Remove the coffee powder and place it in the litter bin.
- 10) The machine is ready to make a new coffee.
- 11) At the end of each cycle we suggest to leave inserted the filter unit-holder (16) into the seat of the brewing unit (9) : the filter remain warm and ready to make a new coffee at the correct temperature. (see picture 3)
- 12) **WARNING:** frequently check the level of water in the tank (2). Do not operate the appliance without water!



Ground coffee.

- 1) Place the filter (18) in the filter-holder unit for ground coffee (16) to pour one cup of coffee.
- Place the filter (19) in the filter-holder unit for ground coffee (16) to pour two cups of coffee.
- 2) Make sure that the thermometer hand is in position of the coffee cup symbol.

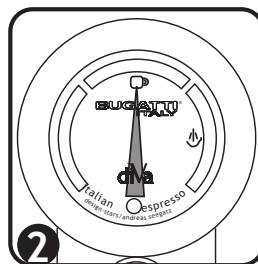
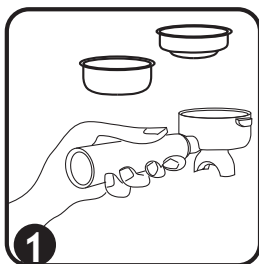

Advice and recommendations for use

3) Take the filter-holder unit for ground coffee (16) insert the filter (18) for one coffee or the filter (19) for two coffees, according to requirements.

3) Pour the ground coffee with the appropriate measure (23): one measure for one coffee or two measures for two coffees, according to the chosen filter.

4) Level the coffee powder inside the filter with the appropriate pressing tool.

5) Insert the filter-holder unit (16) into the seat of the brewing unit (9) and fix it by rotating the handle to the right to about the centre of the machine (handle must be rotated until correct pressure for a seal during delivery is reached).

6) Take one or two dry and warm coffee cups from the cup-warming surface and place them under the spout of the filter holder.

7) Press the button (4) to start delivery of the coffee.

8) Then press the button (4) again to stop delivery of the coffee: you can decide what type of coffee to enjoy: "ristretto", "espresso", "lungo" or ...

9) Serve the coffee immediately to fully enjoy its aroma.

10) Remove the filter-holder unit (16) from the brewing unit (9) by turning the handle to the left.

11) Remove the coffee powder and place it in the litter bin. (See chapter: Cleaning and Maintenance)

12) The machine is ready to make a new coffee.

13) At the end of each cycle we suggest to leave inserted the filter unit-holder (16) into the seat of the brewing unit (9) : the filter remain warm and ready to make a new coffee at the correct temperature. (see picture 5)

14) **WARNING:** frequently check the level of water in the tank (2). Do not operate the appliance without water!

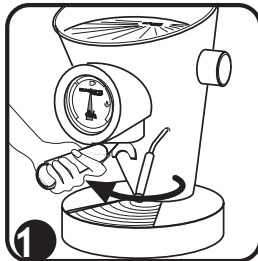
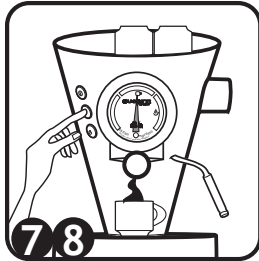
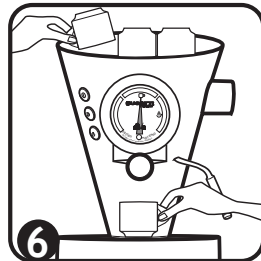
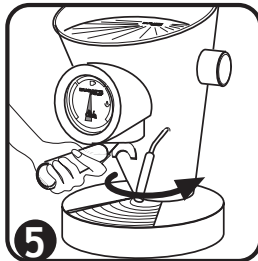

Using steam to prepare milk for cappuccino and for heating water for tea.

- 1) Start the machine by pressing the main on-off (3) switch, open the steam tap for a few seconds by turning the steam knob (10) counterclockwise so as to stop condensation building up.
- 2) Close the tap again by turning the steam knob (10) clockwise.
- 3) Press the steam switch (5) and wait for the thermometer indicator to reach range shown for steaming, then open the tap (10) to deliver the steam. Steam can be delivered for a maximum of 90 seconds.
- 4) To obtain more steam, release the steam switch (5) and shut the tap (10).
- 5) Press the coffee-delivery button (4) until water emerges from the brewing unit (9) and then repeat the previous operations from point 3) of this paragraph.
- 6) After using the steam nozzle, always remember to press switch (5) to cut off the steam again.
- 7) **Important:** To immediately bring up the machine to the ideal temperature for coffee, after shutting off the tap (10) and making sure that the switch (5) is off, press the coffee-delivery button (4) until water emerges from the brewing unit (9).
- 8) The machine is ready to make coffee again.
- 9) Every time you fill up the water tank (2), remember to empty the waste water tank located under the drip grid (14).
- 10) **WARNING:** frequently check the level of water in the tank (2). Do not operate the appliance without water!

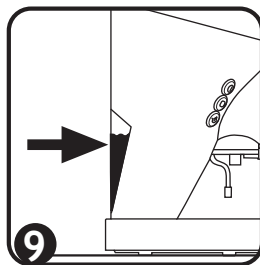
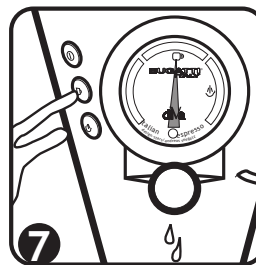
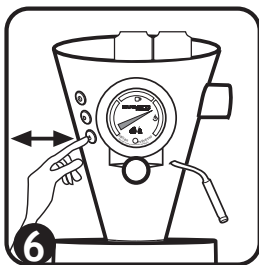
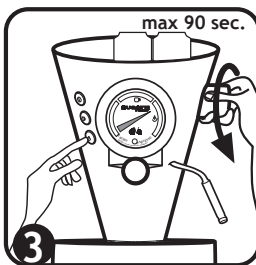

Advice and recommendations for use

Preparing cappuccino.

To make a delicious Italian-style cappuccino, carefully follow this procedure:

- 1) Prepare espresso coffee in one or more Bugatti cappuccino cups (depending on how many cups you want to make). Follow instructions on making espresso coffee on page 25.
- 2) Half fill a jug with cold milk.
- 3) After pressing the steam switch (5), wait for the indicator on the thermometer (6) to reach the range shown for steaming.
- 4) Move the steam nozzle (8) to a comfortable position, place the jug under the nozzle and immerse the nozzle in the milk.
- 5) Open the steam tap by gradually turning the steam knob (10) counterclockwise.
- 6) The steam from the nozzle will blow into the milk to produce the typical froth of a true Italian cappuccino.
- 7) When enough froth has been created, shut the steam tap by turning the steam knob (10) clockwise.
- 8) **Remember to press the steam switch (5) to shut off the steam.**
- 9) Remove the jug from the steam nozzle.
- 10) Add the frothy milk to the espresso coffee that was previously prepared in the special cups (point 1). Sprinkle powdered cocoa on the froth and enjoy your cappuccino.
- 11) **Important:** To immediately bring up the machine to the ideal temperature for coffee, after shutting off the tap (10) and making sure that the switch (5) is off, press the coffee-delivery button (4) until water emerges from the brewing unit (9).
- 12) **The machine is ready to make coffee again.**
- 13) To clean the residual milk from the steam nozzle (8), first wait for the nozzle to cool to prevent burning. Then remove the extractable steam nozzle protection (12) by gently pulling on it and alternately turning it to the right and to the left. Clean the side hole of the steam nozzle protection (12) with a toothpick, then wash it thoroughly inside and outside. Use a damp sponge to remove the remaining milk from the nozzle (8). Clean the hole of the steam nozzle (8) with a toothpick (see the cleaning and maintenance sector). Use a damp sponge to remove the remaining milk from the nozzle (8) and from the protection device (12). Use the steam knob (10) to open the steam tap and to let the steam or drops of water escape for a few seconds (2-3). Reconnect the protection device (12) on the steam nozzle (10).
- 14) Every time you fill up the water into the tank (2), remember to empty the waste water tank located under the drip grid (14).
- 15) **WARNING:** frequently check the level of water in the tank (2).

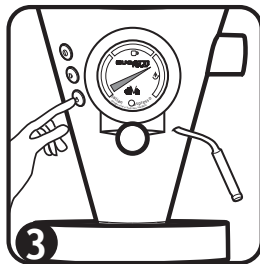
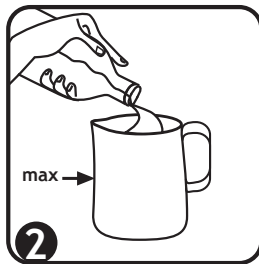
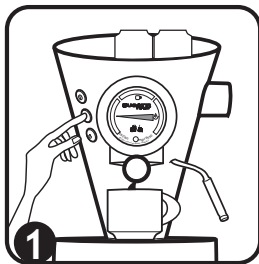

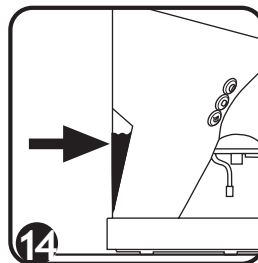
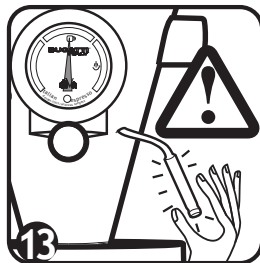
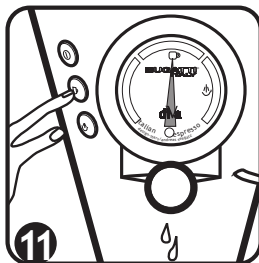
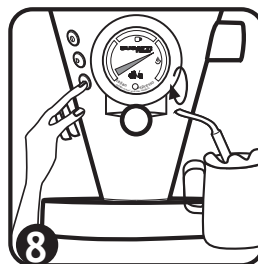
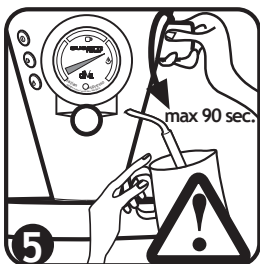

The best espresso coffee

To be excellent, espresso coffee must have the following features:

- 1) The serving of ground coffee must be seven grams (to the nearest half gram).
- 2) The temperature of the water leaving the machine must be 88 °C (give or take 2 °C depending on the type of coffee blend).
- 3) The temperature of espresso coffee must be 67 °C.
- 4) Water-delivery pressure must be 9 atmospheres.
- 5) Percolation time, i.e. the time that the coffee takes to pass through the nozzle into the cup must be 25 seconds (give or take two seconds).
- 6) There must be 25 millilitres of coffee in the cup. (give or take two and a half millilitres)

To obtain an excellent Italian espresso as served at the bar, BUGATTI recommends using BUGATTI coffee, either powder or in pods. This coffee is exclusively roasted in a wood-burning oven, especially for diVa.

Cleaning and maintenance

Before cleaning the machine, turn the main switch to the OFF position and remove the plug from the socket. Wait for the machine to cool. The appliance must be cleaned with a freshly dampened non-abrasive cloth soaked with a few drops of neutral non-corrosive detergent (never use solvents). After using the machine always clean the filter and filter holders and wipe the stainless-steel surface of the filter holder and of the brewing unit with a damp cloth.



H: Cleaning filters for ground coffee: Ensure that the holes in the filter are free from coffee grounds. If necessary, clean them with a small brush

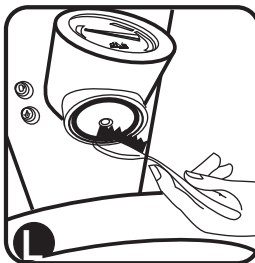

L: Cleaning the brewing unit (9) and its gasket. Regularly clean the gasket under the brewing unit (9) with a wet brush (Figure L) in order to remove all coffee residues. The gasket must be cleaned all the time

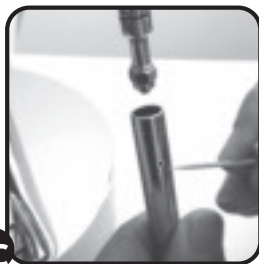
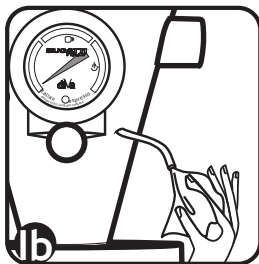
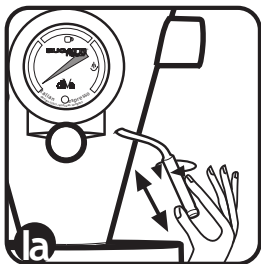

1a/1b/1c To clean the residual milk from the steam nozzle (8), first wait for the nozzle to cool to prevent burning. Then remove the extractable steam nozzle protection (12) by gently pulling on it and alternately turning it to the right and to the left. Clean the side hole of the steam nozzle protection (12) with a toothpick, then wash it thoroughly inside and outside. Use a damp sponge to remove the remaining milk from the nozzle (8). Clean the hole of the steam nozzle (8) with a toothpick (see the cleaning and maintenance sector). Use a damp sponge to remove the remaining milk from the nozzle (8) and from the protection device (12). Use the steam knob (10) to open the steam tap and to let the steam or drops of water escape for a few seconds (2-3). Reconnect the protection device (12) on the steam nozzle (10).
14) Every time you fill up the water into the tank (2), remember to empty the waste water tank located under the drip grid (14).

Advice and recommendations for use

Descaling

DiVa has been built with the best materials available on the market today. Careful and accurate processing and the use of the innovative ion exchange filter enable the hardest water to be filtered.

The ion exchange filter should be changed about every 3 to 4 months if the hardness of water is around 20 to 25 F°. We suggest to use distilled water. You can get a new filter from your retailer or from Customer Care at CASA BUGATTI. The ion exchange filter (24) is housed inside the tank and is connected to the pump suction pipe. To replace this filter (24), follow these simple instructions:

- 1) Remove the water tank (2).
- 2) With one hand take the filter (24) and with the other hand pull and rotate alternately clockwise and counterclockwise the suction pipe near the fitting fixed to the filter in such a way that the pipe becomes detached.
- 3) Take the original new CASA BUGATTI filter (24) and fit the suction pipe onto the pipe fitting by exerting pressure and alternately turning clockwise and counterclockwise so that the pipe slides down over the entire length of the pipe fitting.
- 4) Again insert the pipe with the filter into the tank and carefully refit the tank filled with fresh water onto the machine.
- 5) In order to prolong the working life of the Diva, we recommend using water that is low in sodium wherever this is possible.

N.B.: do not use descaling products with the Diva .

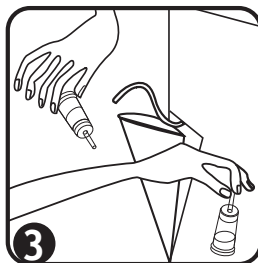
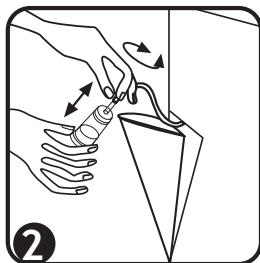
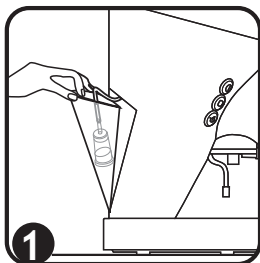

Trouble	Possible cause	Solution
Power-ON light does not light up.	Machine is not powered.	Check correct connection of power supply cable to the wall socket and to the machine. Check that there is electricity in your system.
No coffee delivery. Pump is noisy.	No water in the tank (2). Tank is not correct in its seat.	Fill the water tank (2) with fresh water. Position it correctly in its seat. WARNING : frequently check the level of water in the tank (2)
Coffee tastes burnt.	Steam switch (5) is ON.	Follow procedure at point 6) in section "Using steam", page 26, to bring up the machine to the ideal temperature for coffee again.
Water drops on the drip grille.		Normal discharge, due to the fact that drops of coffee should finish out of the shower filter holder (15)
During the milk frothing we cannot get the typical of cappuccino froth.	a. The pointer of the thermometer has not yet reached the sector of steam b. The steam nozzle (8) and its protection (12) are blocked	a. Make sure the steam button (5) is turned on and wait that the pointer of the thermometer (6) is in the sector of steam. b. Clean the side hole of the steam nozzle protection (12) with a toothpick, then wash it thoroughly inside and outside (see the cleaning and maintenance chapter).
Coffee is not hot	a. The cups are cold b. The filter-holder (16) unit is cold c. The heating element of the boiler is damaged	a. Leave the cups on the warmer plate (1) or rinse them with hot water before use with the coffee machine b. Leave the filter-holder unit (16) in the seat of the brewing unit (9) so that it is always hot and ready for a new coffee at the correct temperature c. Please call the courtesy service office or send an e-mail to Bugatti at diva@casabugatti.it to book the assistance. Please note that the heating element is considered as expendable material and therefore is outside the protection of the warranty (The warranty protects the original defective components that are faulty from its origin due to manufacturing faults).
Leaking of water between the filter-holder unit (16) and the brewing-unit (9)	a. There is coffee powder residue on the gasket of the brewing-unit (9) and / or on the edge of the filter-holder (16) b. If you're making a coffee with the ESE pods: the pod is not positioned correctly in the middle of the filter basket (15) c. If you are making coffee with the ground coffee: there is too much coffee in the filter you are using: filter (18) to 1 cup or filter (19) for two cups d. The seal of the distribution unit (9) is worn-out	a. Regularly clean the gasket under the brewing unit (9) with a wet brush (Figure L) in order to remove all coffee residues. The gasket must be cleaned all the time (See section cleaning and maintenance). b. Place the pod in the center of the filter (15) c. Put into the filter "1cup" (18) no more than 7 grams or one cup of the measuring cup (23) of ground coffee. Put 2 cups into the filter (19) no more than 14 grams or two cups of measuring cup (23) of ground coffee. d. Please call the courtesy service office or send an e-mail to Bugatti at diva@casabugatti.it to book the assistance. Please note that the gaskets are considered as expendable material and therefore is outside the protection of the warranty (The warranty protects the original defective components that are faulty from its origin due to manufacturing faults).

WARRANTY

- 1) A warranty is deemed to be the replacement or repair free of charge of the parts making up the appliance that are faulty from its origin due to manufacturing faults.
- 2) In the event of irreparable or repeated faults having the same origins, at the manufacturer's sole discretion, the machine will be replaced.
- 3) The warranty does not cover damage due to: incorrect or faulty use, defects caused by accidental breakages or carelessness, failure to observe instructions and warnings, incorrect installation and maintenance, maintenance and/or modifications operated by unauthorised personnel. Use of non-original spare parts, carriage and any other circumstance that cannot be ascribed to manufacturing faults, and any all claims not envisaged by law are excluded.
- 4) The warranty does not cover damage due to improper use and in particular to non-domestic use.
- 5) The manufacturer accepts no liability for any direct or indirect harm or injury to persons, things and domestic animals that may arise from failure to abide by all the safety regulations contained in this manual, especially failure to abide by the instructions on installation, use and maintenance of the machine.
- 6) Any replacement or repair shall not interrupt the warranty period.
The replacement of expendable materials such as filters, seals, resistance, etc, is not covered by the warranty.
- 7) To exercise the above rights, the customer must have returned the attached card duly filled in: Warranties that miss even one of the following parts shall not be taken into consideration: sender's address, retailer's stamp, number and/or date of receipt of payment.

SERVICE CENTRE

In the event of a machine fault, contact an authorised BUGATTI dealer, who will return the machine to the manufacturer.

The purchaser is responsible for all carriage and/or dispatch cost for all repairs not covered by warranty. Where possible, keep the appliance's original packing.



IMPORTANT INFORMATION FOR CORRECT DISPOSAL OF THE PRODUCT IN ACCORDANCE WITH EC DIRECTIVE 2002/96/EC.

At the end of its working life, the product must not be disposed of as urban waste.

It must be taken to a special local authority differentiated waste collection centre or to a dealer providing this service. Disposing of a household appliance separately avoids possible negative consequences for the environment and health deriving from inappropriate disposal and enables the constituent materials to be recovered to obtain significant savings in energy and resources. As a reminder of the need to dispose of household appliances separately, the product is marked with a crossed-out wheeled dustbin.

(DE) Alle Details des Textes wurden gewissenhaft geprüft. Das Unternehmen behält sich das Recht vor, Klarstellungen bereit zu stellen, falls im Text Druckfehler oder irreführender Informationen auftreten. Achtung: Das Unternehmen aktualisiert die Produktdetails in diesem Handbuch fortlaufend, einschließlich der Überarbeitung der technischen Daten, behält sich jedoch das Recht vor, Änderungen ohne vorherige Ankündigung vorzunehmen. Das Aussehen, die Form und Farbe des Produktes basieren auf dem realen Standardprodukt.

(ES) Todos los detalles del texto han sido revisados cuidadosamente. Nuestra compañía se reserva el derecho de proveer aclaraciones en el caso de que el texto contenga errores tipográficos o informaciones erróneas. Cuidado: Nuestra compañía se encarga de la actualización de todos los detalles del producto mostrados en el manual, incluyendo las especificaciones técnicas. No obstante se reserva la facultad de revisar el manual sin aviso previo. La perspectiva, la forma y el color del producto se inspiran al producto real estándar.

(PT) Todos os detalhes do texto foram devidamente verificados. A nossa empresa reserva-se o direito de fornecer qualquer outro esclarecimento no caso em que o texto apresente gralhas ou informações pouco claras. Atenção, A nossa Empresa mantém atualizados os detalhes do produto constantes no manual de instruções, incluindo as revisões das características técnicas; reserva-se a faculdade de efetuar modificações sem pré-aviso. A perspectiva, a forma e a cor do produto foram inspiradas no produto real padrão.

(NL) Alle details van deze tekst zijn zorgvuldig gecontroleerd. Het bedrijf behoudt zich het recht voor om toelichting te bieden m.b.t. de tekst in het geval van drukfouten of misleidende informatie. Opmerking: Het bedrijf werkt de details van het product in deze handleiding bij, met inbegrip van de herziening van de technische specificaties en behoudt zich het recht voor om wijzigingen aan te brengen zonder waarschuwing vooraf. Het voorkomen, de vorm en de kleur van het product zijn gebaseerd op het huidige product.

(RU) Вся информация, изложенная в данном тексте, была тщательно проверена. Компания оставляет за собой право на предоставление любых пояснений, если в тексте имеются опечатки или же вводящая в заблуждение информация. Внимание: Компания обновляет информацию об изделии, содержащуюся в инструкции, включая пересмотр технических характеристик. Тем не менее, она оставляет за собой право на внесение изменений без предварительного уведомления. Вид, форма и цвет изделия похожи на его реальный, стандартный вариант.

(CS) Všechny detaily obsažené v textu byly pečlivě zkontrolovány. Firma si vyhrazuje právo poskytnout veškerá ujasnění v případě případných chyb nebo zavádějících informací. Pozor: Firma aktualizuje detaily týkající se výrobku obsažené v tomto návodu k používání, včetně revizí technických specifikací. Nicméně si vyhrazuje právo na provedení změn bez předchozího upozornění. Perspektiva, tvar a barva výrobku jsou inspirovány standardním skutečným výrobkem.

(RO) Toate detaliile textului au fost atent verificate. Fabrica își rezervă dreptul de a furniza orice clarificări în cazul în care există în text erori de imprimare sau informații care induc în eroare. Atenție: Fabrica actualizează detaliile despre produs prezente în manualul de instrucțiuni, inclusiv revizuirea specificațiilor tehnice. Cu toate acestea, își rezervă dreptul de a aduce modificări fara aviz în prealabil. În perspectivă, forma și culoarea produsului se inspira din produsul standard real.

(FI) Koko teksti on tarkistettu yksityiskohtaisesti. Yritys pidättää itselleen oikeuden antaa lisäselvityksiä, jos tekstissä on painovirheitä tai harhaanjohtavia tietoja. Huomio: Yritys pitää käyttöohjeessa olevat tuotetiedot (myös teknisten tietojen korjaukset) päivitettyinä. Se pidättää itselleen kuitenkin oikeuden tehdä muutoksia ilman ennakoilmoitusta. Näytetyt ulkonäkö, muoto ja väri vastaavat todellista vakiotuotetta.

(AR) تم تدقيق جميع تفاصيل النص بعناية. الشركة تحتفظ بحقها بتقديم أي توضيح في حال وجود أخطاء طباعة أو معلومات مضللة في النص.
تنبيه: الشركة تحافظ على تحديث تفاصيل المنتج الموجودة في كتيب التعليمات بما فيها مراجعة الخصائص الفنية؛ الشركة تحتفظ بحقها بإدخال التعديلات دون إنذار مسبق. المظهر، الشكل ولون المنتج مستوحاة من المنتج الواقعي المعياري.

(GR) Όλες οι πληροφορίες του κειμένου έχουν ελεγχθεί προσεκτικά. Η εταιρεία μας διατηρεί το δικαίωμα να παρέχει τυχόν διευκρινίσεις σε περίπτωση ύπαρξης τυπογραφικών λαθών ή παραπλανητικών πληροφοριών. Προσοχή: η εταιρεία ενημερώνει τακτικά τα στοιχεία του προϊόντος που περιλαμβάνονται στο εγχειρίδιο χρήσης συμπεριλαμβανομένων και των τεχνικών προδιαγραφών. Επιφυλάσσεται επίσης του δικαιώματος να επιφέρει τροποποιήσεις χωρίς ουδεμία προειδοποίηση. Η εμφάνιση, το σχήμα και το χρώμα του προϊόντος βασίζονται σε τυπικά χαρακτηριστικά πραγματικών προϊόντων.

(SV) All information i texten har kontrollerats noggrant. Företaget förbehåller sig rätten att komma med förtydliganden av texten i händelse av tryckfel eller vilseledande information. Viktigt! Företaget uppdaterar kontinuerligt produktinformationen i denna bruksanvisning vilket även inbegriper revision av tekniska data. Företaget förbehåller sig rätten att göra ändringar utan föregående meddelande. Produktens utseende, form och färg bygger på den verkliga produkten i standardutförande.

(DA) Samtlige specifikationer i teksten er blevet nøje kontrolleret. Virksomheden forbeholder sig ret til at meddele en hvilken som helst præcisering i tilfælde af trykfejl eller vildledende oplysninger i teksten.
Advarsel: Virksomheden holder produktspecifikationerne i brugsanvisningen opdateret, inkl. ændringer i de tekniske specifikationer. Virksomheden forbeholder sig imidlertid ret til at udføre ændringer uden forudgående varsel. Produktets udseende, form og farve følger det reelle standardprodukt.

(PL) Wszystkie szczegóły podane w tekście starannie sprawdzono. Producent zastrzega sobie prawo do udzielania wszelkich wyjaśnień w przypadku pojawienia się błędów drukarskich lub przekazania mylnych informacji. Uwaga: Producent aktualizuje zawarte w instrukcji obsługi szczegółowe dane na temat produktu oraz dokonuje aktualizacji specyfikacji technicznej. Zastrzega sobie jednak prawo do wprowadzania zmian bez wcześniejszego o tym poinformowania. Widok perspektywiczny, kształt oraz kolor produktu opierają się na standardowym produkcie rzeczywistym.

(IT) Tutti i dettagli del testo sono stati attentamente controllati. L'azienda si riserva il diritto di fornire qualsiasi chiarimento in caso nel testo ci siano errori di stampa o informazioni fuorvianti. Attenzione: L'azienda mantiene aggiornati i dettagli di prodotto presenti nel manuale istruzioni, incluse le revisioni delle specifiche tecniche; si riserva comunque la facoltà di apportare modifiche senza preavviso. La prospettiva, la forma e il colore del prodotto si ispirano al prodotto reale standard.

(EN) All the details of the text have been carefully checked. Our company reserves full right to explain the elaboration of the text if there is any printing error or misleading information. Note: Please be reminded that our company keeps updated every product detail shown on the instruction book, including technical specification. We reserve to revise the instruction book without prior notice. All product' outlook, shape and color are based on the standard of actual physical products.

(FR) Tous les détails du texte ont été contrôlés attentivement. Notre entreprise se réserve le droit de fournir tous les éclaircissements qui s'imposeront au cas où le texte contiendrait des erreurs d'impression ou des informations trompeuses. Attention : Nous continuerons de mettre à jour les détails de produit présents dans le manuel d'instructions, compris les révisions des spécifications techniques. Nous nous réservons toutefois la faculté d'apporter des modifications sans préavis. La perspective, la forme et la couleur du produit s'inspirent du produit standard réel.

"See on the internal pages: (DE), (ES), (PT), (NL), (RU), (CS), (RO), (FI), (AR), (GR), (SV), (DA), (PL)"

15-DIVAMANUALE



concept & design: **stars_andreas seegatz**

Ilcar di Bugatti S.r.l.
via Industriale, 69
25065 Lumezzane (BS)-Italia
tel. +39.030.89.280
fax +39.030.89.28.250
www.casabugatti.com
diva@casabugatti.it

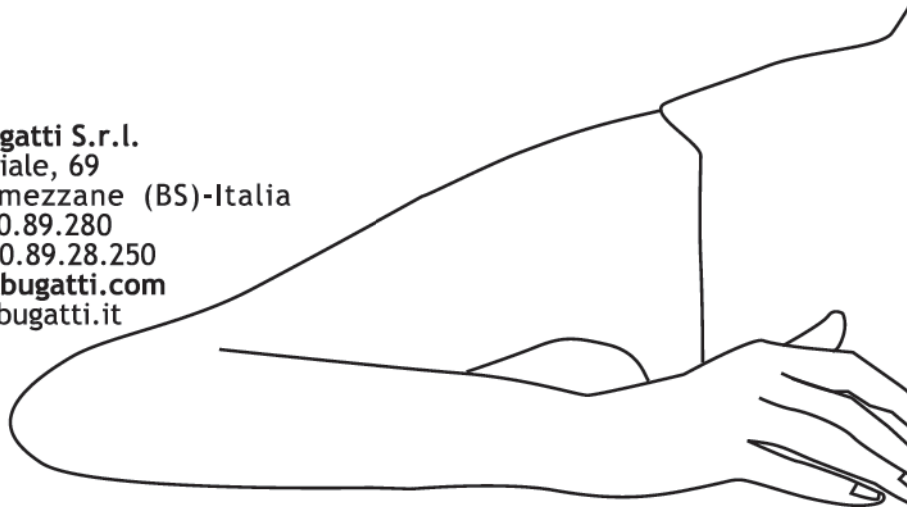

ATTENZIONE/ATTENTION

Dati cliente/final customer address

Nome/name

Indirizzo/address

Cap/zip

Città/city

Stato/country

Autorizzazione ai sensi della legge 675/96
sulla tutela dei dati personali / Consent
to use your personal data information complying
with privacy law 675/96.

Firma

BUGATTI®





**GARANZIA
WARRANTY
GARANTIE
GARANTÍA
ГАРАНТИЯ
ZARUKA
TAKUU**
質量保証
無償保証サービス

etichetta matricola



**Timbro/Nome/Indirizzo rivenditore
Retailer stamp/name and address**

**Numero documento fiscale e data acquisto:
Number and/or date of receipt of payment:**