

Smart Plug Gen3

With Power Meter

User Manual

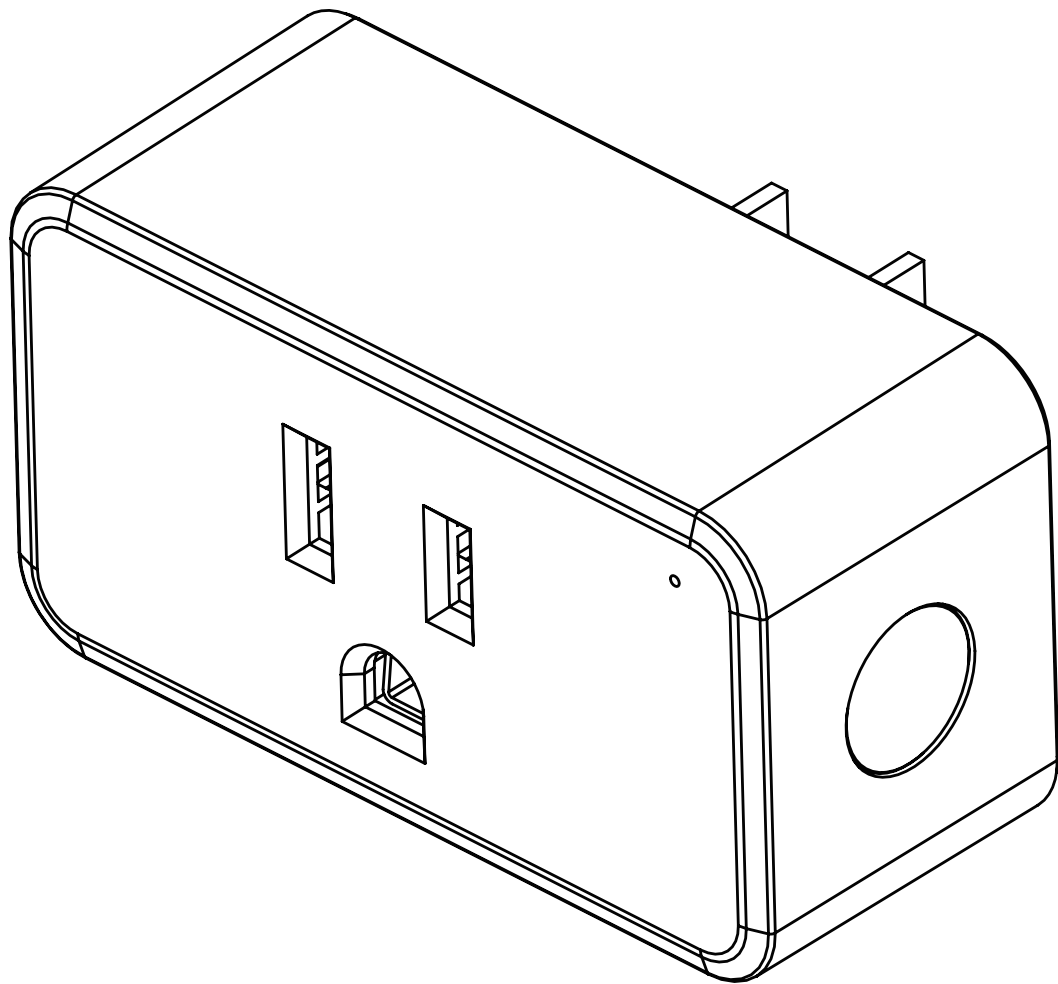

 THIRD REALITY

Contents

Specifications	01
Features	01
Setting up your Smart Plug Gen3	02
Factory Reset	02
Pairing with compatible Zigbee devices.....	03
Pairing with SmartThings	04
Pairing with Amazon Alexa	06
Pairing with Hubitat	09
Pairing with Home Assistant	12
Mesh Network Setup	18
Using your smart Plug Gen3 by Alexa	19
Troubleshooting	20
FCC Regulatory Conformance	22
Limited Warranty	23

Specifications

Model Number	3RSP02064Z
Electrical Characteristics	100~120V AC, 15A Max, 50/60Hz
Working Temperature	-10°C~40°C
Operating Humidity	5%~90% RH (Non-condensing)
Connectivity	Zigbee 3.0
App Support	IOS/Android

Features

1. Support real-time energy monitoring
2. Compatible with Zigbee devices from Amazon Echo / SmartThings / Home Assistant / Hubitat / Homey / Third Reality etc.
3. Act as a Zigbee repeater, increasing the range of your Zigbee mesh network.
4. Customize On/Off state when power is restored.
5. Enjoy worry-free upgrades with continuous power.

Setting up your Smart Plug Gen3

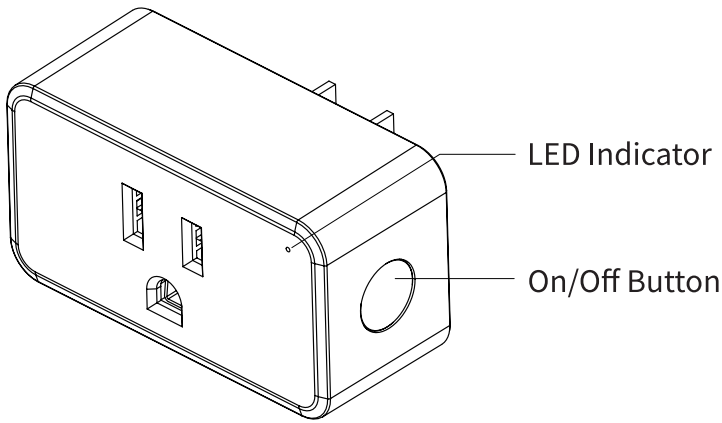

LED Status

Pairing: The LED flashes in red.

Pairing Completed: LED light is OFF.

Power ON: LED light is ON in red.

Power OFF: LED light is OFF.

Insert the Smart Plug into an outlet, it will enter pairing mode automatically.

Factory Reset

After your Smart Plug is powered on, press and hold the On/Off button for more than 10 seconds until the LED light flashes in red indicating that your Smart Plug is in pairing mode.

Pairing with compatible Zigbee devices

Compatible devices: Echo 4th Gen, Echo Plus 1st Gen/2nd Gen, Echo Show 10 2nd Gen, Echo Show 10 3rd Gen, Echo Studio. Eero 6, Eero 6 Pro, Homey, Aeotec, SmartThings Station, SmartThings 2015/2018, Hubitat Elevation, Home Assistant (ZHA/Zigbee2MQTT), Third Reality Hub, Smart Bridge MZ1.

1. Update your hub firmware and phone app to the latest version before pairing, set up your Zigbee Hub by following its user manual.
2. Insert the Smart Plug into an outlet, it will enter pairing mode automatically.
3. Follow the instructions in the corresponding phone app to complete the setup.

Pairing with SmartThings

Compatible Devices: SmartThings Hub 2015&2018, Aeotec Smart Home Hub, SmartThings Station.

App: SmartThings App



Pairing steps:

1. Check your SmartThings Hub for firmware updates before pairing the Smart Plug with it.
2. Power on the Smart Plug, press and hold the On/Off button for more than 10 seconds until the LED light flashes in red indicating that your Smart Plug is in pairing mode. It exits pairing mode within 3 minutes if not successfully paired. To put it into pairing mode again.
3. Tap "+" in the upper right in your SmartThings app, then tap "Scan for nearby devices", the Smart Plug will be paired within seconds.
4. You can turn on or off the plug, or you can create a routine to control it.

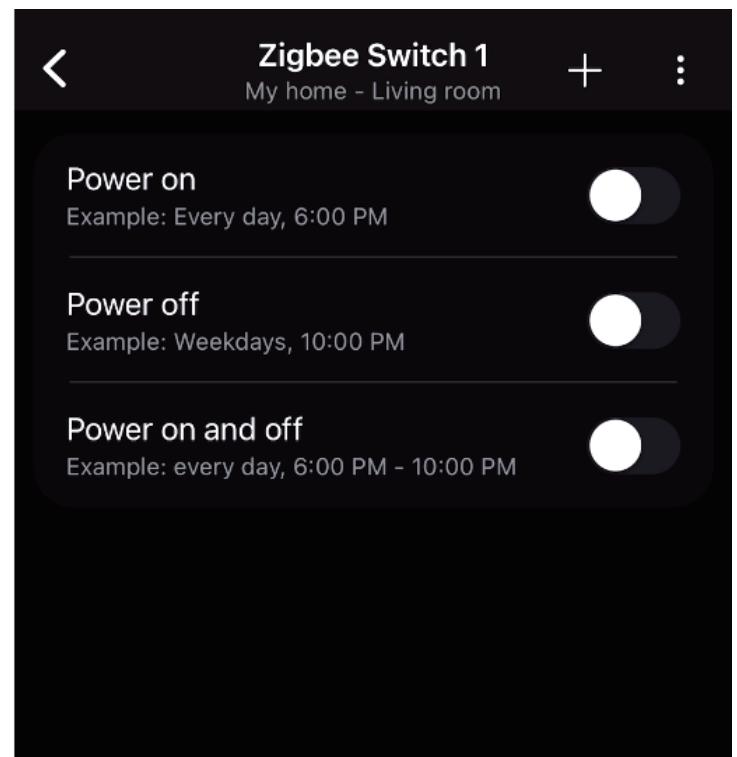
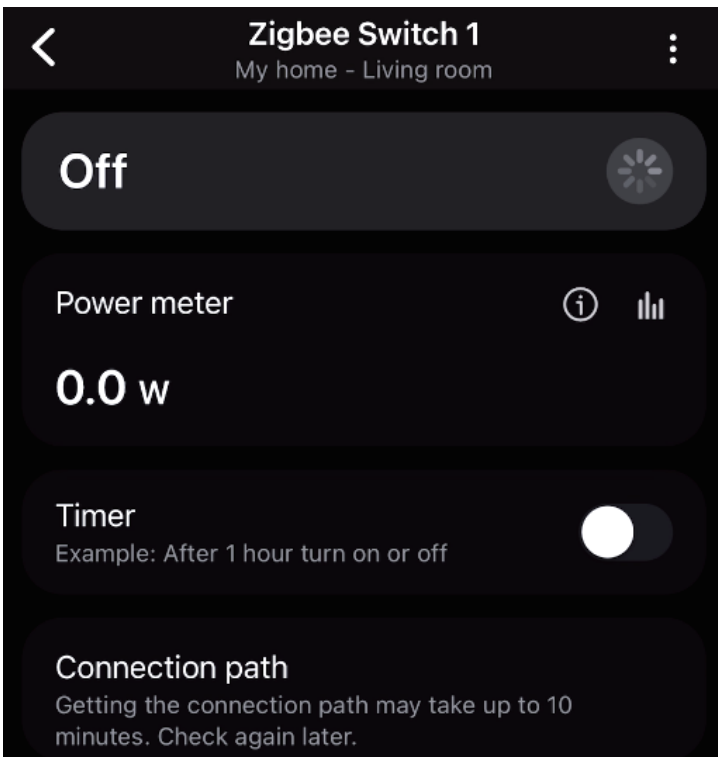
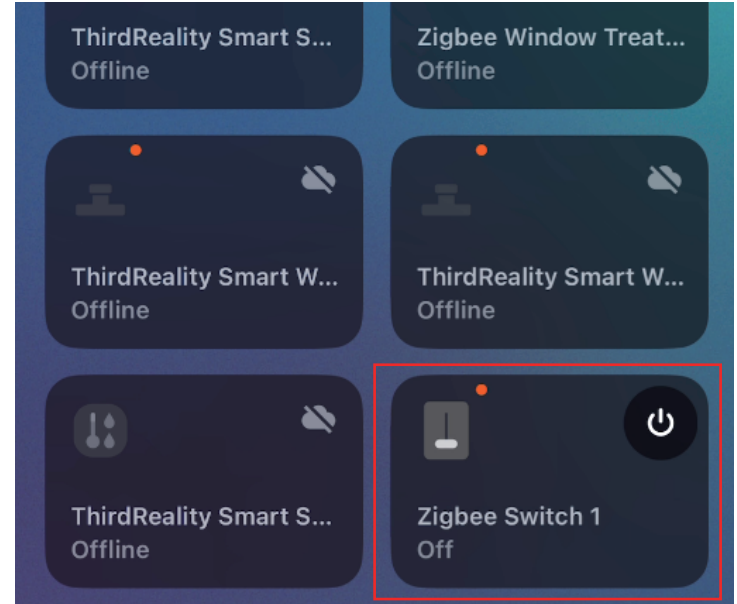
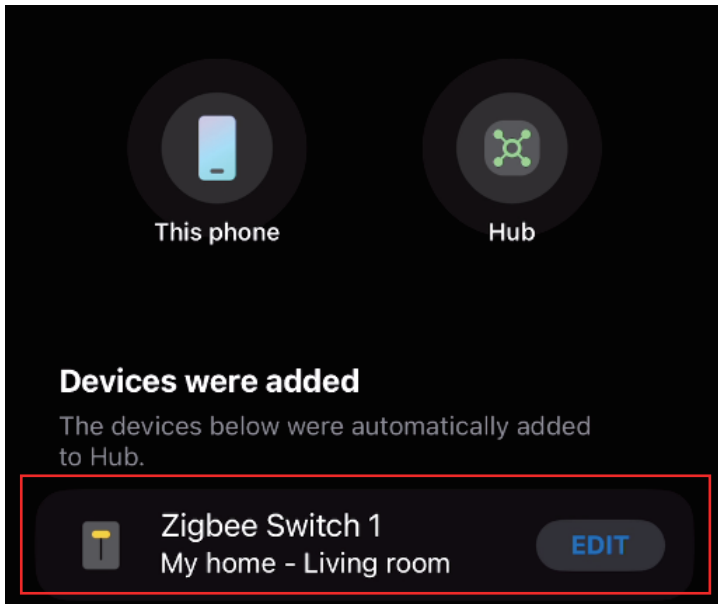
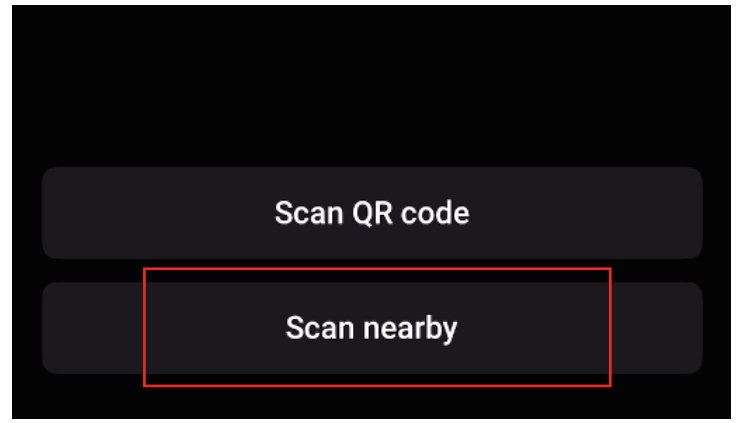
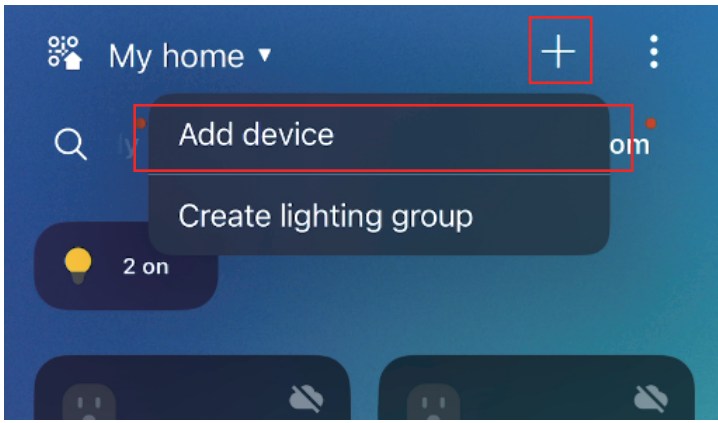

Pairing with Amazon Echo

Compatible Devices: Echo 4th Gen, Echo Plus 1st Gen/2nd Gen, Echo Show 10 2nd Gen, Echo Show 10 3rd Gen, Echo Studio, Eero 6, Eero 6 Pro.

App: Amazon Alexa App



Pairing steps:

1. Check your Echo speaker for firmware updates before pairing.
2. Power on the Smart Plug, then press and hold the On/Off button for more than 10 seconds until the LED light flashes in red indicating that your Smart Plug is in pairing mode. It exits pairing mode within 3 minutes if not successfully paired. To put the device into pairing mode again.
3. Tap "+" in the upper right in your Alexa app to "Add Device", scroll down to select "Other", then choose Zigbee connection to add the device, or simply ask Alexa to discover devices, the Smart Plug will be paired within seconds.
4. You can turn on or off the plug through the voice assistant or the Echo app on your phone, or you can create a routine to control it.

Devices +

 Explore Smart Home features >

Groups See all





Add Device
Echo, Smart Home, and Accessories



Add Group
Create rooms, device groups, and larger areas



Combine speakers

 Water Leak Detector

 Other

   Message Alexa... 

 matter  Bluetooth

 zigbee  Wi-Fi

When you discover devices, Alexa may connect additional compatible devices in your home. You can learn about or delete these devices in device settings.

Discover Devices





1 Other plug found and connected

Your plug has been added to your Alexa account. Next, we'll help you finish setting up your device.

Continue

Devices

 Device Type ▼ Sort By ▼

 Second blind Off

 **Smart Plug Gen3**
• Recently added Off

 First blind
• Device is unresponsive

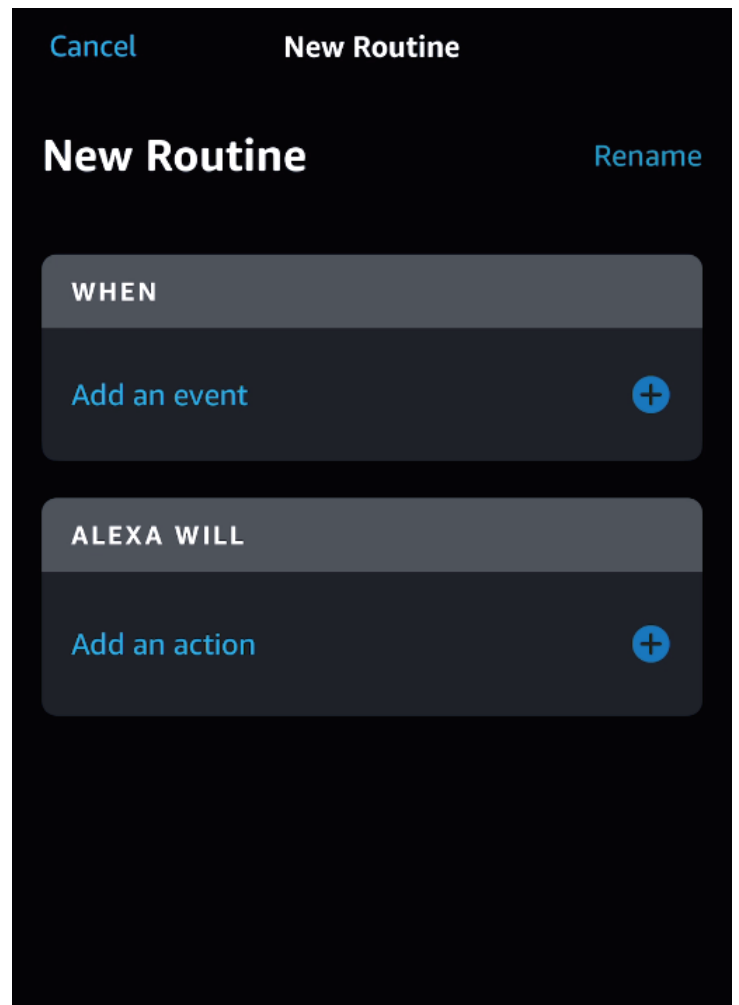
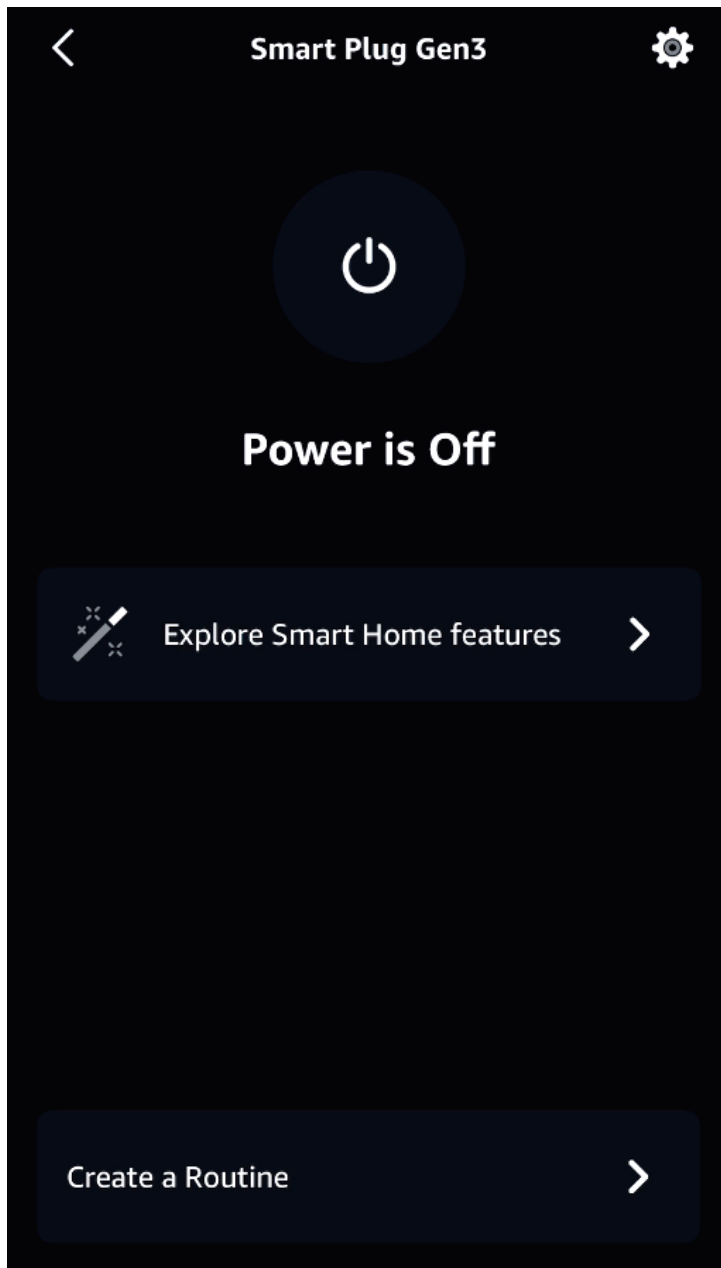

Pairing with Hubitat

Website: <http://find.hubitat.com/>



Pairing steps:

1. Before pairing the Smart Plug with Hubitat Elevation, check for a firmware update on your Hubitat settings page.
2. Power on the Smart Plug, then press and hold the On/Off button for more than 10 seconds until the LED light flashes in red indicating that your Smart Plug is in pairing mode. It exits pairing mode within 3 minutes if not successfully paired. To put the device into pairing mode again.
3. Tap + Add a device in the Devices page. Choose Zigbee to add device manually. The Smart Plug will be paired within seconds, then you can rename it and edit its location.
4. Tap + Add a device in the Devices page.
5. Choose Zigbee to add device manually
6. The Smart Plug will be paired within seconds, then you can rename it and edit its location.

6. Change Type from "Device" to "Generic Zigbee Outlet".
7. Now you can turn on or off the Smart Plug.

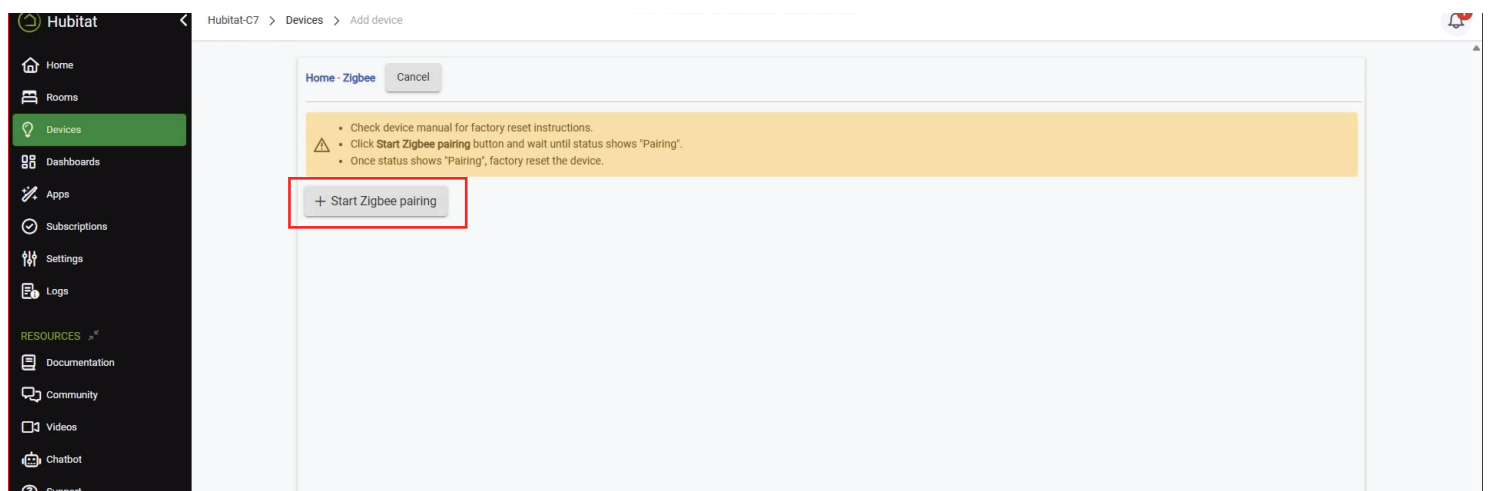
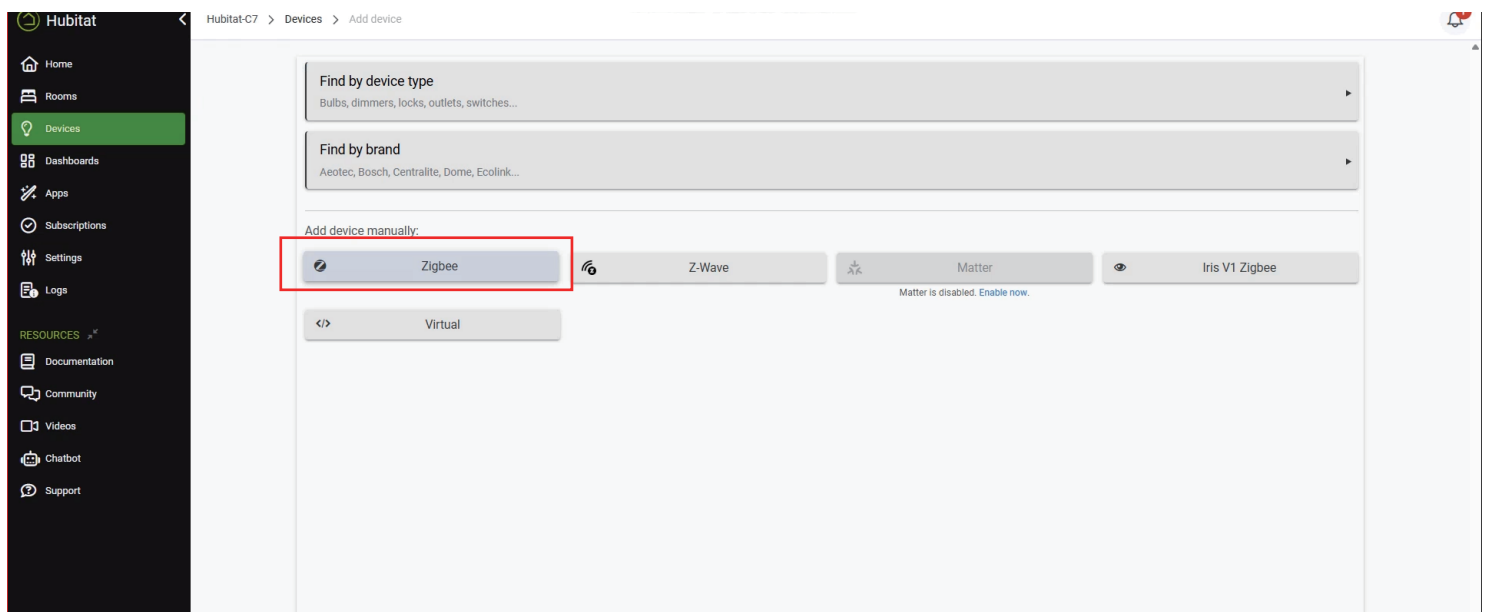
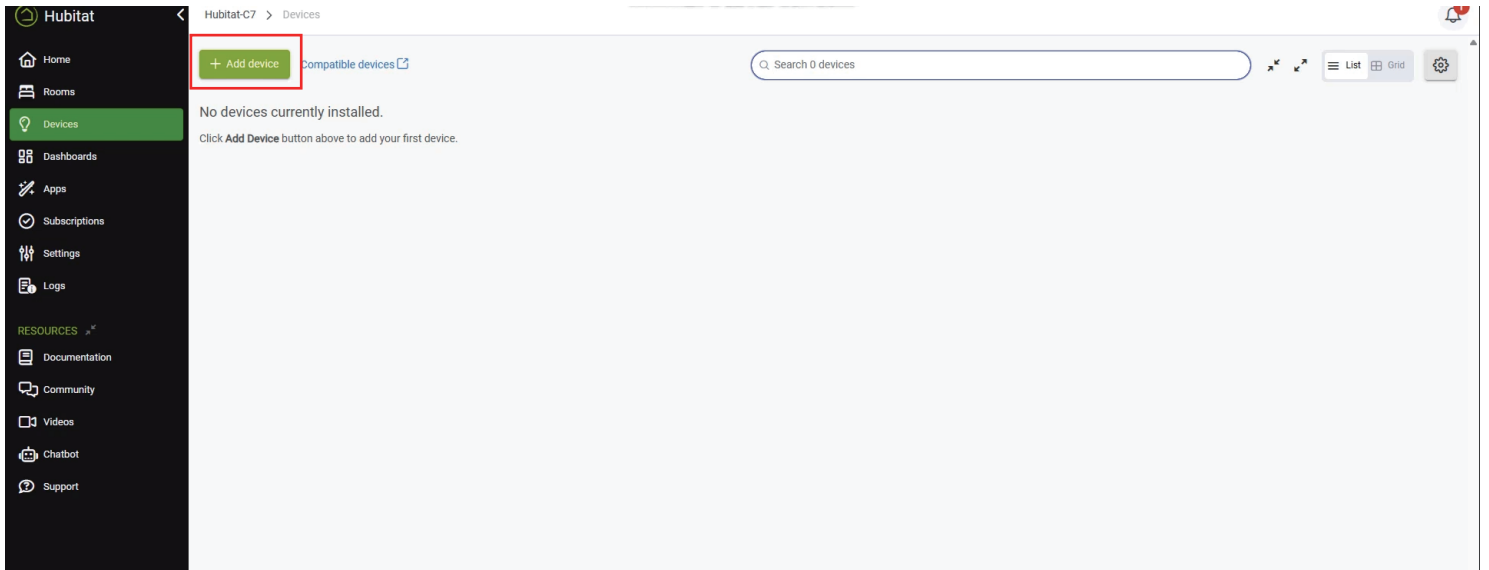

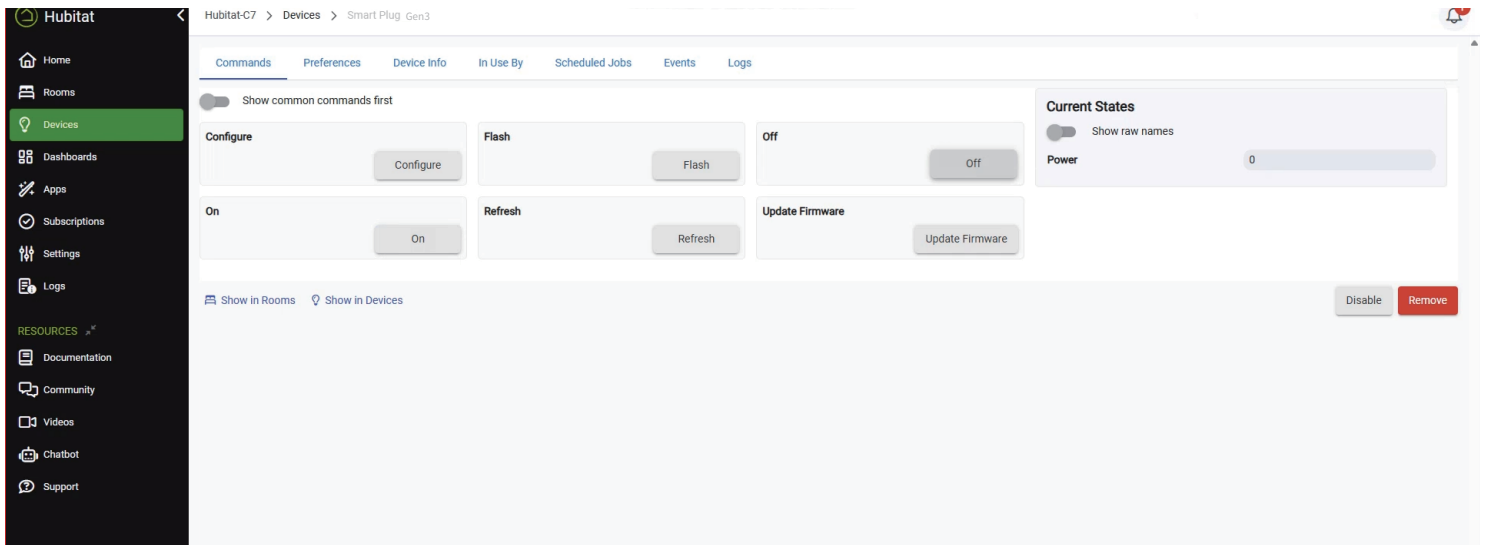
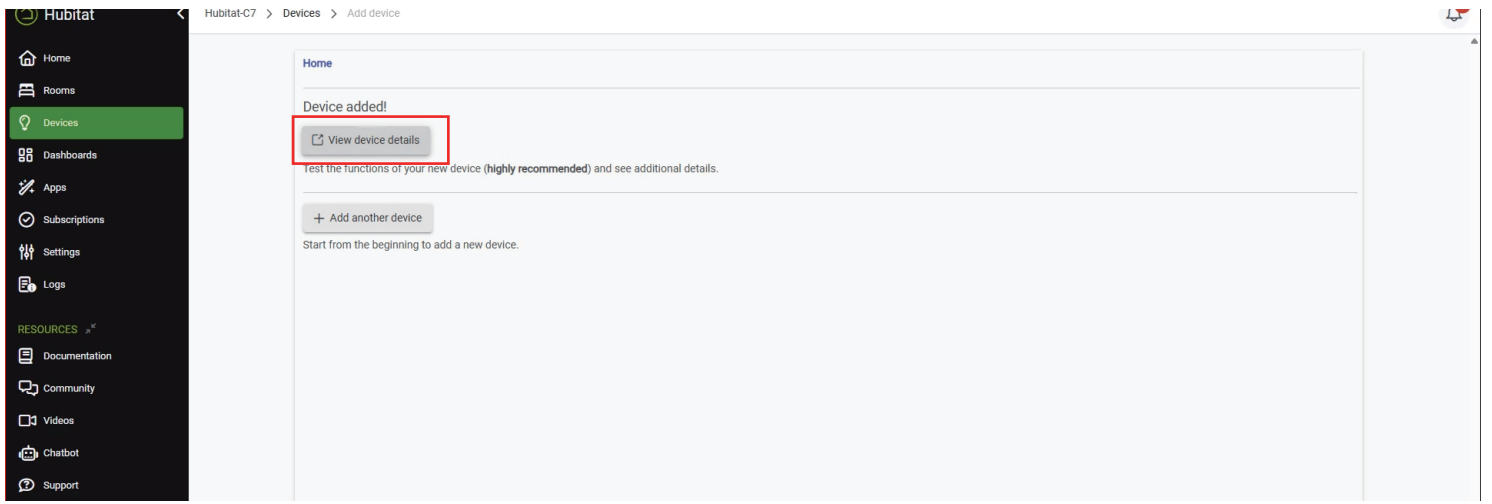

Pairing with Home Assistant



Pairing steps:

Zigbee Home Automation(ZHA)

1. Power on the Smart Plug, then press and hold the On/Off button for more than 10 seconds until the LED light flashes in red indicating that your Smart Plug is in pairing mode. It exits pairing mode within 3 minutes if not successfully paired to the hub. To put the device into pairing mode again.
2. Ensure the Home Assistant Integration Zigbee Home Automation Setup is ready, then navigate to the "Settings" page and click "Devices & Services".
3. After that click the "Devices" on the Zigbee item, and then click "Add Devices".
4. After the pairing is completed successfully, it will show up on the page.

5. Back to "Devices", then you can find the smart Plug added.
6. Click to enter in the control interface to set the Smart Plug, you can then monitor the active a power and preset on/off satates after power outage in the Devices page.

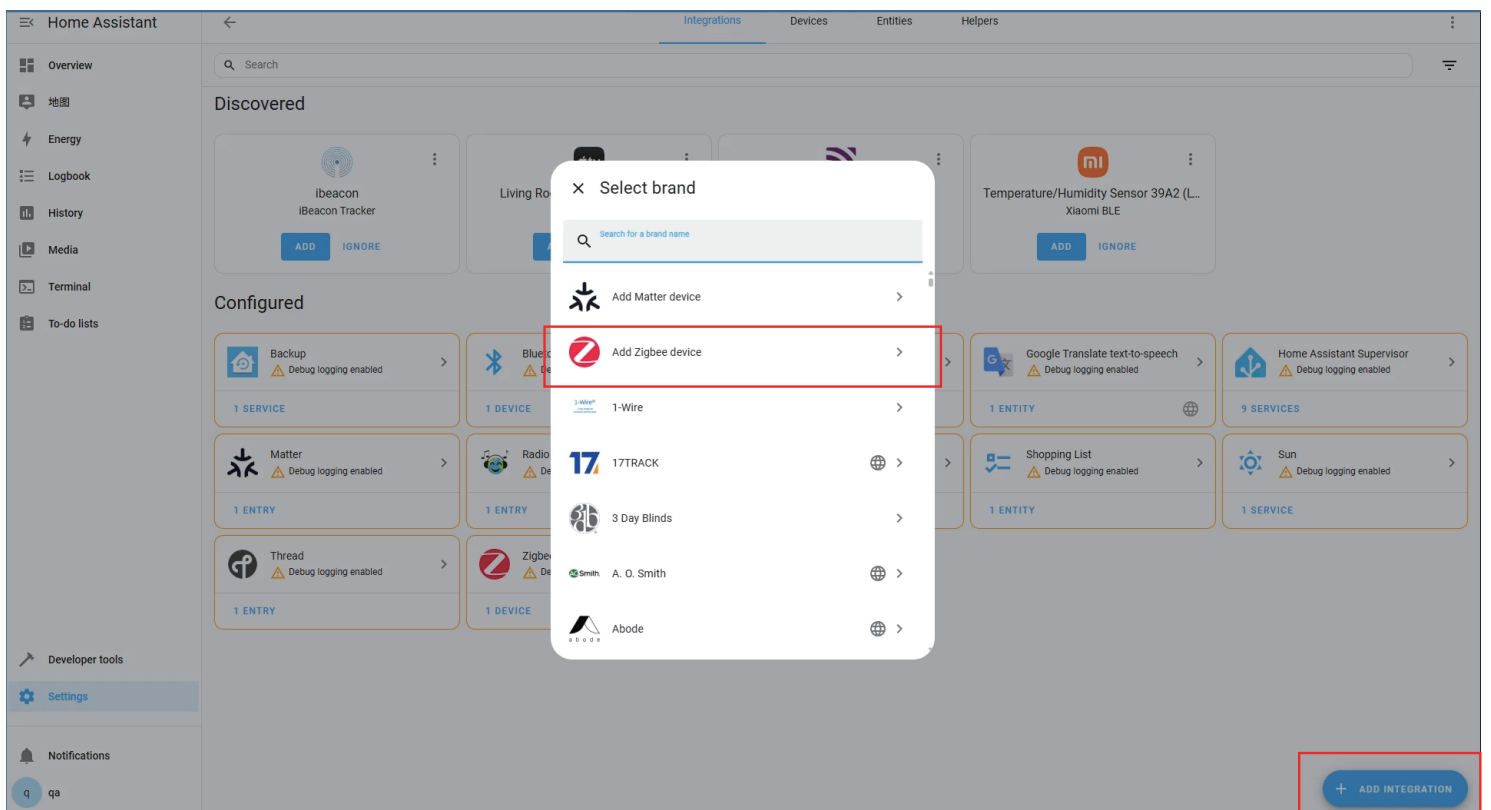
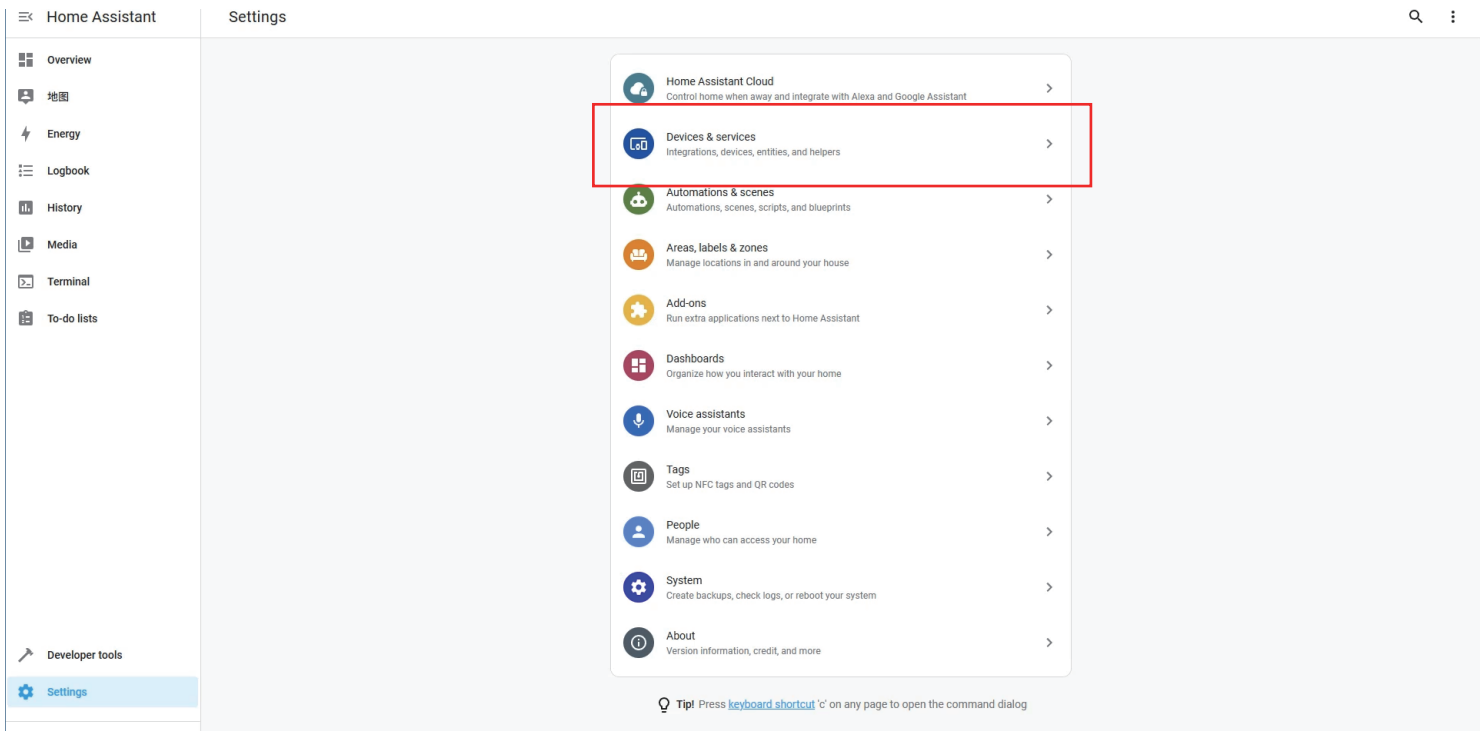

- Overview
- 地图
- Energy
- Logbook
- History
- Media
- Terminal
- To-do lists

- Developer tools
- Settings

Searching for Zigbee devices...



Initialization complete

The device is ready to use

3RSP02064Z
by Third Reality, Inc

Change device name
Third Reality, Inc 3RSP02064Z

Area

- Overview
- Energy
- Activity
- History
- File editor
- Media
- Terminal
- To-do lists
- Zigbee2MQTT

- Developer tools
- Settings

- Notifications

Filters Search 3 devices Group by Sort by Device

Device	Area	Integration	Manufacturer	Model	Battery
SONOFF ZBDongle-E	-	Zigbee Home Automation	SONOFF	ZBDongle-E	-
Third Reality, Inc 3RDTS01056Z	-	Zigbee Home Automation	Third Reality, Inc	3RDTS01056Z	67%
Third Reality, Inc 3RSP02064Z	-	Zigbee Home Automation	Third Reality, Inc	3RSP02064Z	-

+ Add device



- Overview
 - Energy
 - Activity
 - History
 - File editor
 - Media
 - Terminal
 - To-do lists
 - Zigbee2MQTT
-
- Developer tools
 - Settings 3
 - Notifications



Device info

3RSP02064Z
by Third Reality, Inc
Connected via [SONOFF ZBDongle-E](#)
Firmware: 0x0000023

Zigbee info

- Zigbee Home Automation
- Reconfigure

Controls

Third Reality, Inc 3RSP020...

[Add to dashboard](#)

Sensors

AC Frequency	50.0 Hz
Current	0.0 A
Open	Closed
Power Factor	0.0%
Power Supply	0.0 W
Total Delivered	0.000 kWh
Voltage	107.4 V

[Add to dashboard](#)

Configuration

Firmware Up-to-date

固件名称 PreviousValue

[Add to dashboard](#)

Activity

November 14, 2025

Third Reality, Inc 3RSP02064Z turned off triggered by action Switch. Turn off
10:23:40 AM - 2 minutes ago - 0

Third Reality, Inc 3RSP02064Z turned on triggered by action Switch. Turn on
10:23:33 AM - 2 minutes ago - 0

Automations

No automations have been added using this device yet. You can add one by pressing the + button above.

Scenes

No scenes have been added using this device yet. You can add one by pressing the + button above.

Scripts

No scripts have been added using this device yet. You can add one by pressing the + button above.

- Overview
 - Energy
 - Activity
 - History
 - File editor
 - Media
 - Terminal
 - To-do lists
 - Zigbee2MQTT
-
- Developer tools
 - Settings 3
 - Notifications

When

A trigger is a specific event happening in or around your home, for example: 'When the sun sets'. Any trigger added here will start your automation.

[+ Add trigger](#)

And if (optional)

All conditions added here need to be satisfied for the automation to run. A condition can be satisfied or not at any given time, for example: 'If 0 is home'. You can use building blocks to create more complex conditions.

[+ Add condition](#) [+ Add building block](#)

Then do

All actions added here will be performed in sequence when the automation runs. An action usually controls one of your areas, devices, or entities, for example: 'Turn on the lights'. You can use building blocks to create more complex sequences of actions.

[+ Add action](#) [+ Add building block](#)

[Save](#)



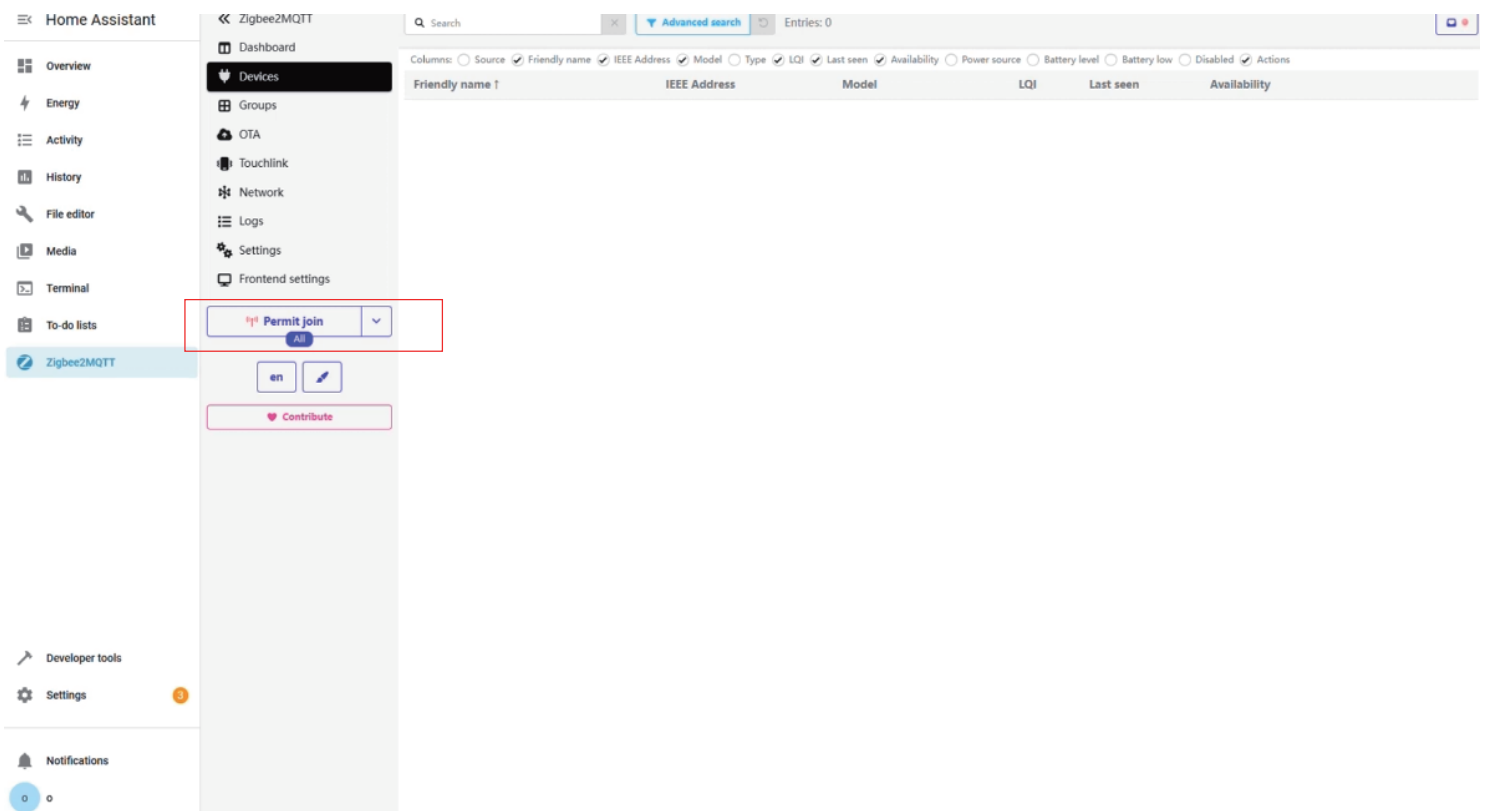

Zigbee2MQTT

1. Power on the Smart Plug, then press and hold the On/Off button for more than 10 seconds until the LED light flashes in red indicating that your Smart Plug is in pairing mode. It exits pairing mode within 3 minutes if not successfully paired. To put it into pairing mode again.
2. Click "Permit Join" in Zigbee2MQTT to add the device.
3. Smart Plug has been added successfully.
4. Click the device name to see detailed device information.
5. Now you can turn the Smart Plug on or off in the Exposes page.



Home Assistant << Zigbee2MQTT Search Advanced search Entries: 1

Columns: Source Friendly name IEEE Address Model Type LQI Last seen Availability Power source Battery level Battery low Disabled Actions

Friendly name	IEEE Address	Model	LQI	Last seen	Availability	Actions
0x4ce175521cdf0000	0x4ce175521cdf0000 0x2AEB 10984	3RSP02064Z Third Reality	176	N/A	Disabled	  

Dashboard
Devices
Groups
OTA
Touchlink
Network
Logs
Settings
Frontend settings

Disable join 03:46
en 

Contribute

Home Assistant << Zigbee2MQTT 0x4ce175521cdf0000

About Exposes Bind Reporting Settings Settings (specific) State Clusters Groups Scene Dev console

★ State
On/off state of the switch
OFF ON

Power-on behavior
Controls the behavior when the device is powered on after power loss
off on toggle previous

Power
Instantaneous measured power
0 W

Voltage
Measured electrical potential value
107.4 V

AC frequency
Measured electrical AC frequency
50 Hz

Power factor
Instantaneous measured power factor
0

Current
Instantaneous measured electrical current
0 A

Energy
Sum of consumed energy
0 kWh

Linkquality
Link quality (signal strength)
192 lqi

Permit join AD
en 

Contribute

192.168.0.1:68123/api/hassio_ingress/AJxH.tk4mdkL53WVTjkcChGsd8e050RQxsGTzOFw/#/device/0x4ce175521cdf0000/exposes

Mesh Network Setup

If you want to have multiple plugs set up for different rooms, especially rooms out of the range of the Echo Devices Zigbee signal range, you can utilize Mesh Network setup to extend the range.

1. First, set up the smart plugs close to the Echo Device.
2. Unplug the plug and move it further away from the Echo Device. And make sure it's within Zigbee range of another active plug, which is connected on the network as a node. This will form a Zigbee Mesh Network. Each connected plug will connect with other plugs (nodes) within the range.

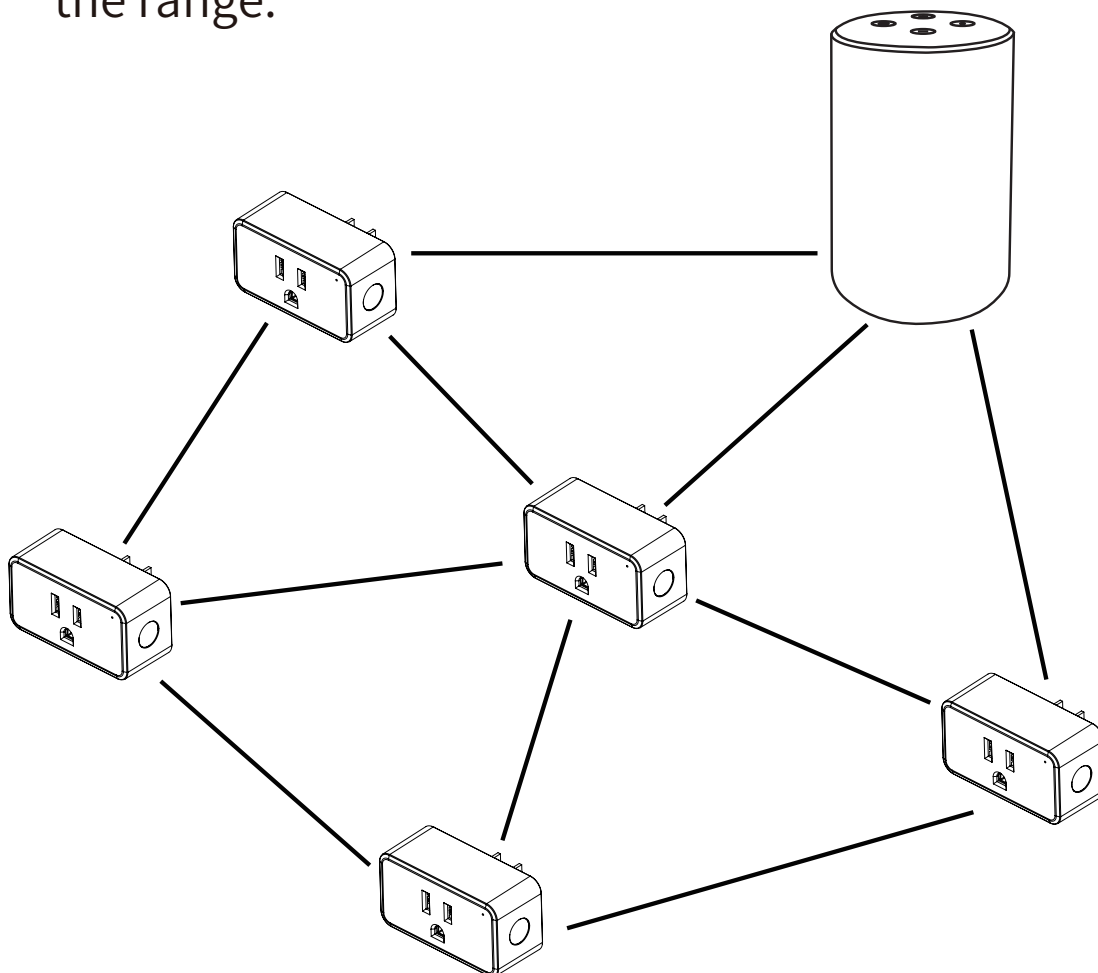

Using your Smart Plug Gen3 by Alexa

1. Control the Smart Plug via voice command, say " Alexa, turn on/off First Plug ".
2. Schedules or timers to turn the Smart Plug ON/OFF automatically.
3. Create routines to enjoy your smart life, say " Alexa, good morning " to turn on the coffee maker, etc.
4. Remotely control the Smart Plug from your phone even if you are not at home.
5. Use the plugs as extenders, they can help Echo Devices or the Zigbee Hubs to connect with the plugs that are further away from your Echo.

Troubleshooting

1. **Factory reset the Smart Plug Gen3**

After your Smart Plug is powered on, press and hold the On/Off button for more than 10 seconds until the LED light flashes in red indicating that your Smart Plug is in pairing mode.

2. **Fail to pair with Echo or Smart Plug is not responding**

Make sure your Echo Speaker is compatible with Smart Plug (See the Compatible Devices List) and the Smart Plug is in the right mode.

- Please ensure your Echo Devices are set up before adding the Smart Plugs.
- Turn on/off the Smart Plug twice in the Alexa app to sync the plug.
- Reboot the Echo Speaker or Zigbee Hub by unplugging the power and plugging it back in, then try to pair the Smart Plug with it again.
- Factory reset the Echo speaker (Press and hold the Action Button for 25 seconds. The light ring will pulse orange, then turn off. Wait for the light ring to turn back on and turn blue. The light ring then turns orange again and the device enters the setup mode), then try to pair the Smart Plug with it again.

- If still not working, please try to deregister the Echo Speaker and register back in, then try to pair the Smart Plug with it.

3. **Move Smart Plugs**

If you want to move the paired plug from one Echo to another, make sure to remove the plug from the Alexa app and wait 30 minutes to allow cloud synchronization before re-pairing with a different Echo Device:

FCC Regulatory Conformance

This device complies with Part 15 of the FCC Rules. Operation is subject to the following two conditions:

- (1) This device may not cause harmful interference.
- (2) This device must accept any interference received, including interference that may cause undesired operation.

Changes or modifications not expressly approved by the party responsible for compliance could void the user's authority to operate the equipment.

NOTE: This equipment has been tested and found to comply with the limits for a Class B digital device, pursuant to part 15 of the FCC Rules. These limits are designed to provide reasonable protection against harmful interference in a residential installation.

This equipment generates uses and can radiate radio frequency energy and, if not installed and used in accordance with the instructions, may cause harmful interference to radio communications. However, there is no guarantee that interference will not occur in a particular installation. If this equipment does cause harmful interference to radio or television reception, which can be determined by turning the equipment off and on, the user is encouraged to try to correct the interference by one or more of the following measures:

- Reorient or relocate the receiving antenna.
- Increase the separation between the equipment and receiver.
- Connect the equipment into an outlet on a circuit different from that to which the receiver is connected.
- Consult the dealer or an experienced radio/TV technician for help important announcement.

NOTE: The manufacturer is not responsible for any radio or TV interference caused by unauthorized modifications to this equipment. Such modifications could void the user's authority to operate the equipment.

RF Exposure

This equipment complies with FCC radiation exposure limits set forth for an uncontrolled environment. This transmitter must not be co-located or operating in conjunction with any other antenna or transmitter.

Limited Warranty

For limited warranty, please visit

<https://3reality.com/faq-help-center/>

For customer support, please contact us at

info@3reality.com or visit www.3reality.com

For questions on other platforms, please visit for corresponding platform's application/support page.