

ZLINE

RANGES & COOKTOPS

Installation Guide
and Users Manual

CONTENTS

INSTALLATION GUIDE

● IMPORTANT SAFETY INSTRUCTIONS	1
● WARRANTY AND SERVICE	3
● BEFORE INSTALLATION	5
● INSTALLING THE LEGS	7
● ANTI-TIP STABILITY DEVICE & RANGE TOP/DROP-IN INSTALL	8
● INSTALLATION REQUIREMENTS & RANGE TOP/DROP-IN CUT-OUTS	11
● ELECTRICAL CONNECTION	12
● WIRING SCHEMATICS	13
● GAS CONNECTION	15
● GAS CONVERSION PROCEDURE	18
● INSTALLATION CHECKLIST	22
● FINAL PREPARATION	22

CONTENTS

USERS MANUAL

● ROOM VENTILATION	24
● SURFACE BURNER LAYOUT	24
● OVEN COOKING	25
● USING THE OVEN	26
● MAINTAINING YOUR RANGE	30
● TROUBLESHOOTING	32

THANK YOU

We want to thank you for choosing one of our beautiful professional ranges. We know that you have many brands to choose from and we are thrilled that you have decided to place one of our products in your home.

Our appliances are designed according to the strictest safety and performance standards for the North American market. We follow the most advanced manufacturing process. Each appliance leaves the factory after thorough quality inspection and testing. Our distributors and our service partners are ready to answer any questions you may have regarding installation of your ZLINE product.

This manual will help you learn to use the product in the safest, most efficient manner, and care for it so that it may give you the highest satisfaction for years to come.

This manual also includes directions for the professional installer that will install the product in your home. We recommend professional installation by trained personnel.

Please keep this manual for future use.

Range Installation Video

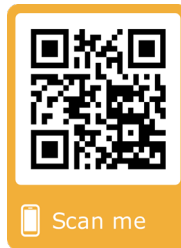

LOCATION OF APPLIANCE TAGS

The rating tag shows the model and serial number of your range. The tag is located under the front edge of the range cooktop. The tag is visible when the oven door is open.

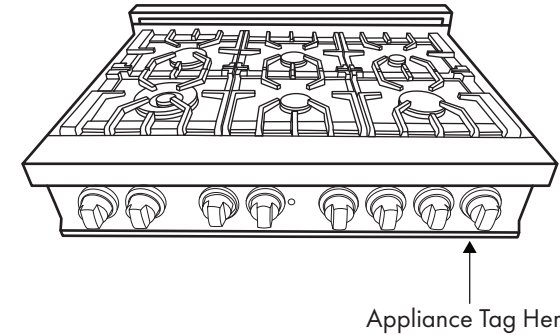

Important Appliance Information

Dealer _____

Model _____

Date Installed _____

Installer _____

IMPORTANT SAFETY INSTRUCTIONS



An air curtain or other overhead range, range, cooktop hood which operates by blowing downward airflow onto the range, shall not be used/installed in conjunction with this gas range.

The manufacturer will not be responsible for any damage to property or to persons caused by incorrect installation or improper use of the appliance.

The manufacturer reserves the right to make changes to its products when considered necessary and useful, without affecting the essential safety and operating characteristics.

This appliance has been designed for non-professional, domestic use only. Do not place any pot or pan on the open oven door, the door is made of glass and can break under the weight.

Before beginning installation, please read these instructions completely and carefully.

Do not remove permanently affixed labels, warnings, or plates from the product.

This may void the warranty. Please observe all local, state and national codes and ordinances. Please ensure the range is properly grounded. The installer should leave these instructions with the consumer who should retain for local inspectors use and for future reference. The plug should always be accessible. Installation must conform with local codes or in the absence of codes, the National Fuel Gas Code NSIZ223.

1/NFPA54. Electrical installation must be in accordance with the National electrical code ANSI/NPA70-latest edition and/or local codes. In Canada: Installation must be in accordance with the current CAN/CGA-fe 149.1 National gas installation code or CAN/CGA-B 149.2, Propane installation code and/or local codes.

Electrical installation must be in accordance with the current CSA C22.1 Canadian electrical codes Part 1 and/or local codes.

Installation of any gas-fired equipment should be made by a licensed plumber. A manual gas shut-off valve must be installed in the gas supply line ahead of the oven in the gas flow for safety and ease of service.

IMPORTANT SAFETY INSTRUCTIONS

Important Safety Information

Please read and follow these important instructions for the safety of your home and the people living in it.



If the information in this manual is not followed exactly, a fire or explosion may result causing property damage, personal injury, or death.

Do not store or use gasoline or any other flammable substances in the vicinity of this or any other appliance.

What To Do If You Smell Gas

- DO NOT light any appliance.
- DO NOT touch any electrical switch.
- DO NOT use any phone in your building.
- Immediately call your gas supplier from a neighbor's phone, follow the gas supplier's instructions.
- In the case you cannot reach the gas supplier, call the fire department.
- Installation and service must be conducted by a qualified installer, service agency, or the gas supplier.



Never use this appliance as a space heater to heat or warm the room. Doing so may result in carbon monoxide poisoning and overheating of the oven.

WARRANTY AND SERVICE

Warranty and Service

All range products carry a one year parts warranty. Service on all products shall be carried out by factory-trained professionals only. For warranty service, please call customer service.

Replacement Parts

Only authorized replacement parts may be used in performing service on this appliance.

Replacement parts are available from ZLINE. Call 1-614-777-5004.

PRODUCT DIMENSIONS



Internal Dimensions

48" Model: 26.5" W/12.5"W x 18.5"D x 14"H

36" Model: 30.5"W x 18.5"D x 14"H

30" Model: 26.5" W x 18.5"D x 14"H

PRODUCT DIMENSIONS

Drop-ins:

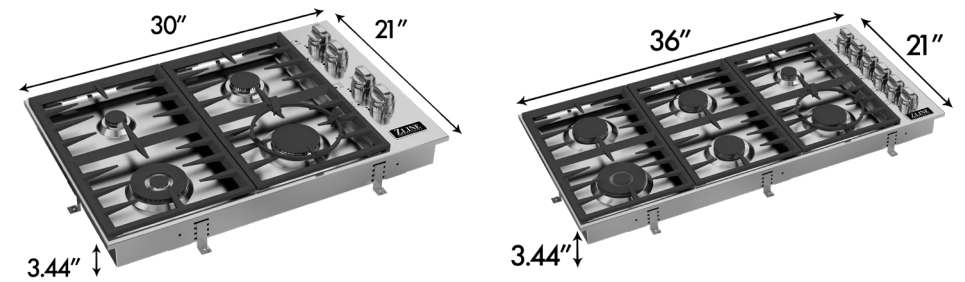

Cooktops:

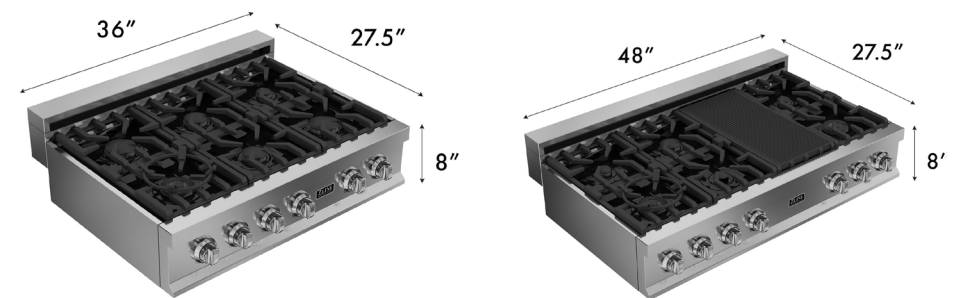

Cooktop cut outs:

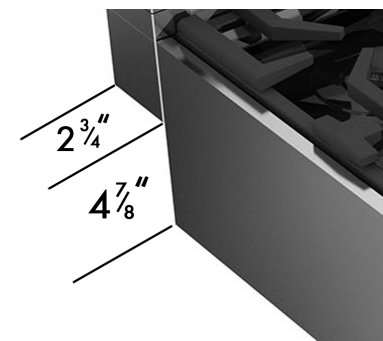

Drop-in & Cooktop
Installation Video

BEFORE INSTALLATION

This appliance shall only be installed by an authorized professional.

The appliance shall be installed in accordance with the standards of the country where it will be installed. The installation of this appliance must conform to local codes and ordinances. In the absence of local codes installation must conform to American National Standards, National fuel Gas code ANSI Z223.1 -Latest edition/ NFPA 54 or B 149.1.

The appliance, when installed, must be electrically grounded in accordance with local codes or, in the absence of local codes, with the National Electrical code, ANSI/NFPA 70.

If local codes permit, a flexible metal appliance connections with the new AGA or CGA certified design, max 5 feet (1,5m) long, 3/4" I.D. is recommended for connecting this appliance to the gas supply line. DO NOT bend or damage the flexible connector when moving the appliance.

This appliance must be used with the pressure regulator provided. The regulator must be properly installed in order to be accessible when the appliance is installed in its final location. The pressure regulator must be set for the type of gas to be used. The pressure regulator has 3/4" female pipe thread. The appropriate fitting must be determined based on the size of your gas supply line, the flexible metal connector and the shut-off valve.

The appliance must be isolated from the gas supply piping system by closing its individual manual shut-off valve during any pressure testing of the gas supply piping system at test pressures equal to or less than 34 PSI (13,8w.cpr 3,5kPA).

All opening holes in the wall and floor, back and under the appliance shall be sealed before installation of the appliance.

A manual valve shall be installed in an accessible location in the gas line external to the appliance for the purpose of turning on and shutting off the gas to the appliance.



Do not use aerosol sprays in the vicinity of this appliance while it is in operation.

BEFORE INSTALLATION

Room Ventilation

An exhaust fan may be used with the appliance; in each case it shall be installed in conformity with the appropriate national and local standards. Exhaust hood operation may affect other vented appliances; in each case it shall be installed in conformity with the appropriate national and local standards.

Type of Gas

This appliance is shipped from the factory for use with natural gas. For use with propane LP gas, please follow the conversion procedure described on pg. 18. A step by step conversion procedure is also included with each set of LP gas nozzles.

Gas Pressure

The maximum inlet gas supply pressure incoming to the gas appliance pressure regulator is 34PSI (13,8w.cpr 3,5kPA).

The minimum gas supply pressure for checking the regulator setting shall be at least 1" w.c (249 Pa) above the inlet specified manifold pressure to the appliance (This operating pressure is 4" w.c. (1.00kPa) for Natural gas and 11" w.c. (2.75 kPa) for LP gas.

Gas cooktop requires 1" - 6" side wall spacing above the counter height for proper combustion. Please review specific model installation instructions for required dimensions. 30 inches between the cooktop and bottom of the cabinet above. 0.25 inches for sides below countertop height.

NOTE: Please consult your local building codes for variations with installation.

INSTALLING THE LEGS

The ranges must be used with the legs properly installed. Four height-adjustable legs are shipped with the range, in a foam container above the range.

INSTALLING THE LEGS

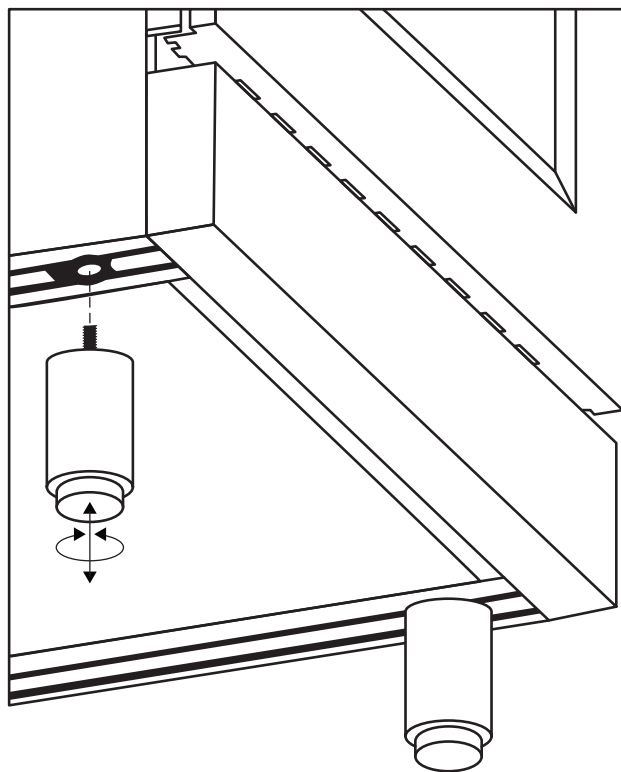

1. Before installing the legs, position the appliance near its final location as the legs are not suitable for moving the appliance over long distances.
2. After unpacking the range, raise it enough to insert the legs in the appropriate receptacles situated on the lower part of the appliance. Lower the range gently to keep any undue strain from legs and mounting hardware.
3. Adjust leg height to the desired level by twisting the inside portion of the leg as-sembly until the proper height is reached. Check with a level that the cooktop is perfectly level.

INSTALLING THE ANTI-TIP STABILITY DEVICE

Installing the Anti-Tip Stability Device

The Anti-tip bracket shipped with the range must be properly secured to the rear wall as shown in the picture on the following page.

The height of the bracket from the floor must be determined after the range legs have been adjusted to the desired height and after the range has been leveled.



A child or adult can tip the range and be killed; Re-engage the anti-tip device if the range is moved. Failure to do so can result in death or serious injury.

RANGE TOP/DROP-IN INSTALLATION

Attaching the hotplate

To prevent liquids from accidentally leaking into the underlying storage space, the appliance is equipped with a special gasket. To apply this gasket, carefully follow the instructions in Fig. 3. Lay out the protective sealing strips along the edges of the opening in the bench top and carefully overlap the strip end. (See Fig. 3).

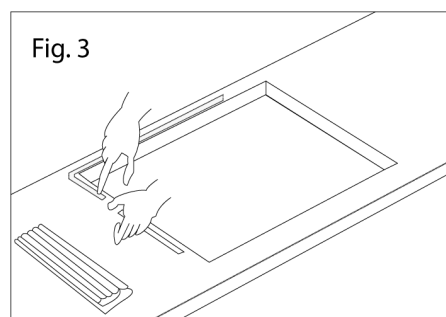

insert the hotplate into the bench top opening. With a screwdriver assemble the brackets (A) to the hotplate bottom by means of the screws (B) (See Fig. 4). Slide the hooks into position and secure them with the screws. Trim the part of the sealing strips that extend beyond the hotplate base.

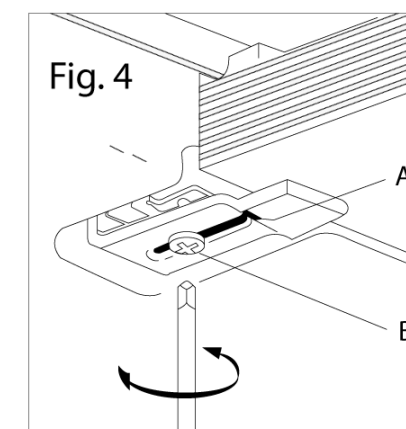

Gas Connection

Please review gas connection on page 15.

INSTALLING THE ANTI-TIP STABILITY DEVICE

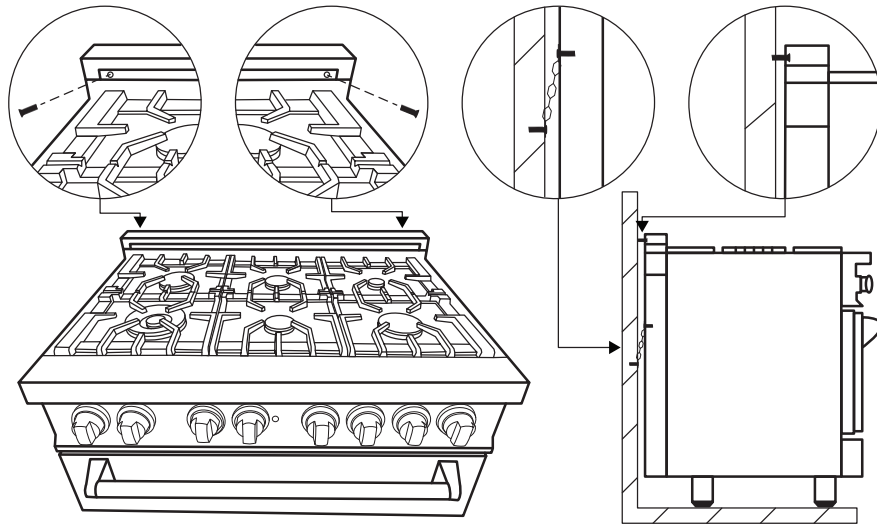

1. Measure the distance from the floor to the bottom of the Anti-Tip bracket receptacle on the back of the appliance.
2. Position the two anti-tip brackets on the wall at the desired height plus $1/8$ " (0.32 cm). The brackets must be placed at $2 \text{ \& } 5/16$ " (6.0cm) from the side of the range. The distance between the two brackets is $25 \text{ \& } 1/4$ " (64.1 cm).
3. Secure the brackets to the wall with appropriate hardware.
4. Slide the range against the wall until the brackets are fully inserted into their receptacles' on the back of the range.
5. Check to see that the Anti-Tip device is installed properly. Then grasp the top rear edge of the range and carefully attempt to tilt it forward. Verify that the Anti-Tip device is engaged.
6. Or use the anti-tip device as one chain, and tighten up with fixed screw on the wall. If the wall is not suitable for installation, then the chain shall be fixed to the cabinet structure.
7. The two sides of the chains are fixed on the wall or cabinet structure.

A properly grounded and horizontally-mounted electrical receptacle type NEMA 14-50R should be installed no higher than 3" above the floor, no less than 2" and not more than 8" from the left side (facing product); refer to electrical connection section.

Gas

An agency-approved, properly-sized manual shut-off valve should be installed no higher than 3" above the floor and no less than 2" and no more than 8" from the right side (facing product).

To connect gas between shut-off valve and regulator, use agency-approved, properly sized flexible or rigid pipe. Check all local code requirements.

Installation Adjacent to Kitchen Cabinets

The range may be installed directly adjacent to existing countertop height cabinets (36") from the floor.

For the best look, the worktop should be level with the cabinet countertop. This can be accomplished by raising the unit using the adjustment spindles on the legs.

ATTENTION: the range CANNOT be installed directly adjacent to kitchen walls, tall cabinets, tall appliances, or other vertical surfaces above 36" high. The minimum side clearance in such cases is 6".

Wall cabinets with minimum side clearance must be installed 30" above the countertop with countertop height between 35.5" and 37.25". The maximum depth of wall cabinets above the range shall be 13".

INSTALLATION REQUIREMENTS

COOKING RANGE

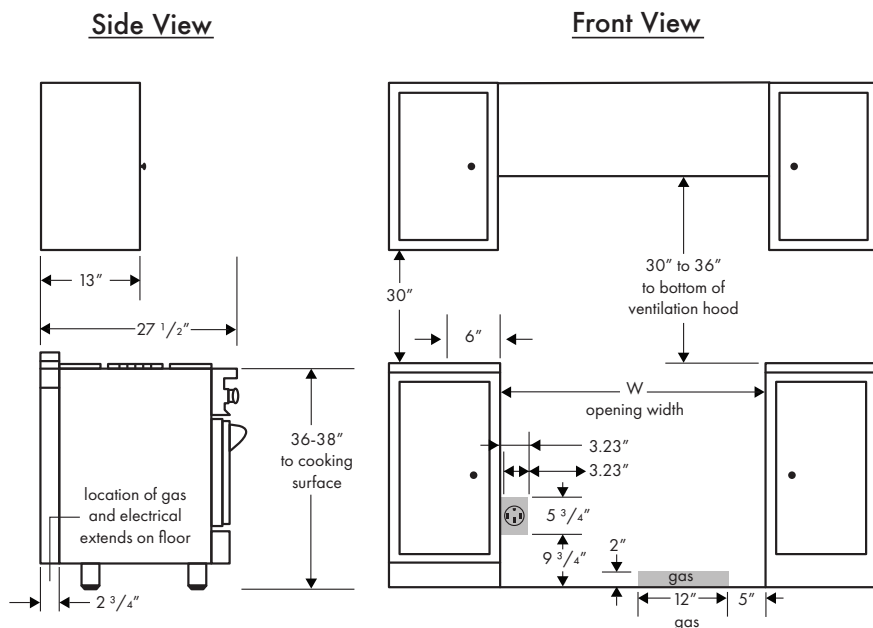

Opening Width

30" Model	30"
36" Model	36"
48" Model	48"

INSTALLATION REQUIREMENTS - RANGE TOP

Table n. 1	A	B	C	D	H1	H2
30 inch	30" (762)	21" (533)	28" 3/8 (720)	18" 7/8 (480)	2" 13/16 (71)	5/8" (15)
36 inch	36" (914)		34" 3/8 (872)			

cut out size	L1			L2			L3
	suggest	min	max	suggest	min	max	min
30 inch	29" (737)	28 9/16" (726)	29 3/8" (746)	19 1/2" (495)	19 1/8" (486)	20 3/8" (517)	2 1/2" (64)
36 inch	35" (889)	34 9/16" (878)	35 3/8" (898)				

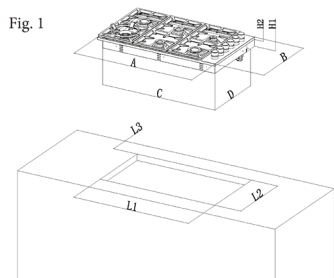
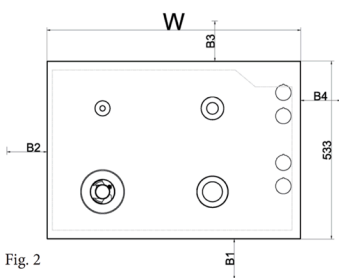

ELECTRICAL CONNECTION

The appliance shall be connected to a single phase electric line rated at 120/208Vac or 120/240Vac and 60Hz frequency.

Electric Power Rating

220/240 Vac: 12A Max

If voltage is less than 220/240 then preheat times may vary.

Heating Element Power Rating

Oven Bake Element: 1500 Watts

Oven Circulation Element: 3200 Watts

Oven Broil Element: 2850 Watts

Install suitable electric power supply receptacle connection type NEMA 14-50R able to support a load of at least 30 A (Per Line) according to local code requirements.

For four wires power supply connection system (see diagram below).

FOUR-WIRE CONNECTION RECEPTACLE NEMA 14-50R

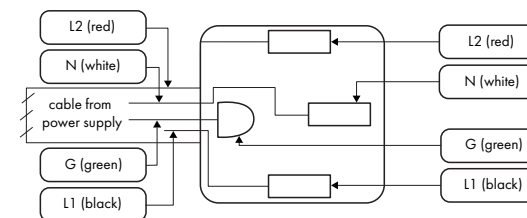

Electrical Grounding

This appliance is equipped with a four-prong plug for your protection against shock hazard and should be plugged directly into a properly grounded receptacle, do not cut or remove the prong from this plug.



Disconnect electrical power at the circuit breaker box or fuse box before installing the appliance.

Provide appropriate ground for the appliance. Use copper conductors only.

WIRING/SCHEMATIC DIAGRAM

Model: RA30, RA36

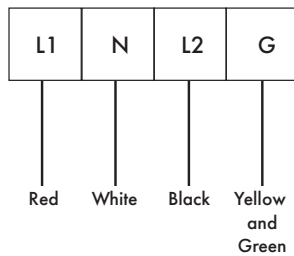
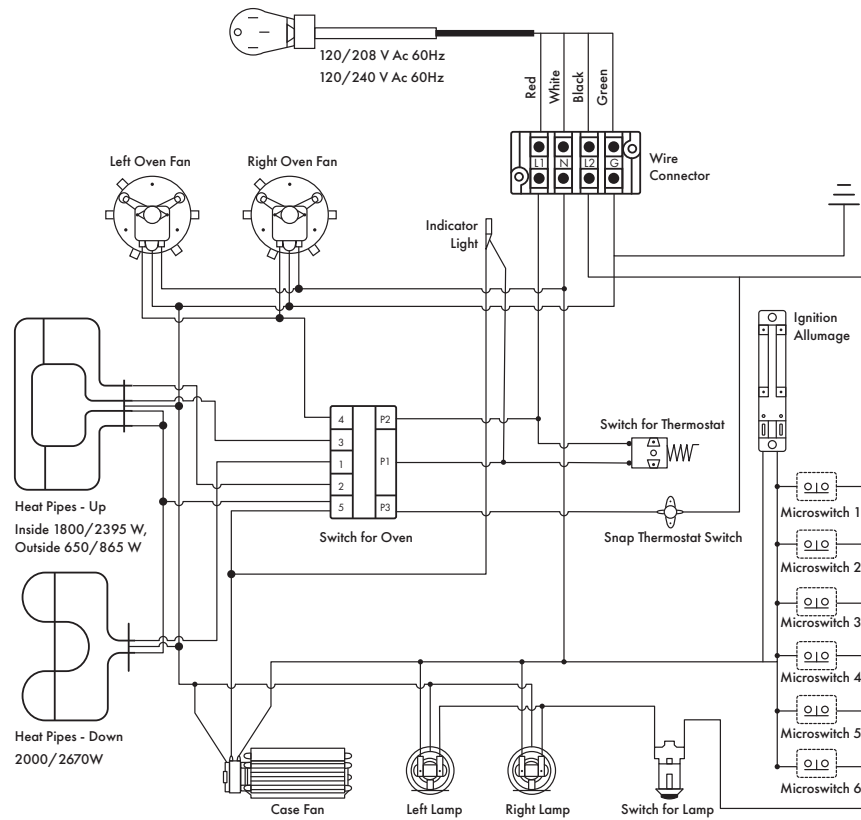

CAUTION: Connect the red wire to the L1 tab (left), the black wire to the L2 tab (right), the white wire to the N tab (central), and the yellow and green wire to the ground screw. DO NOT SWAP CONNECTIONS.

WIRING/SCHEMATIC DIAGRAM

Model: RA48

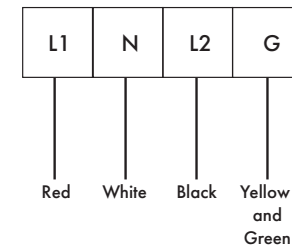
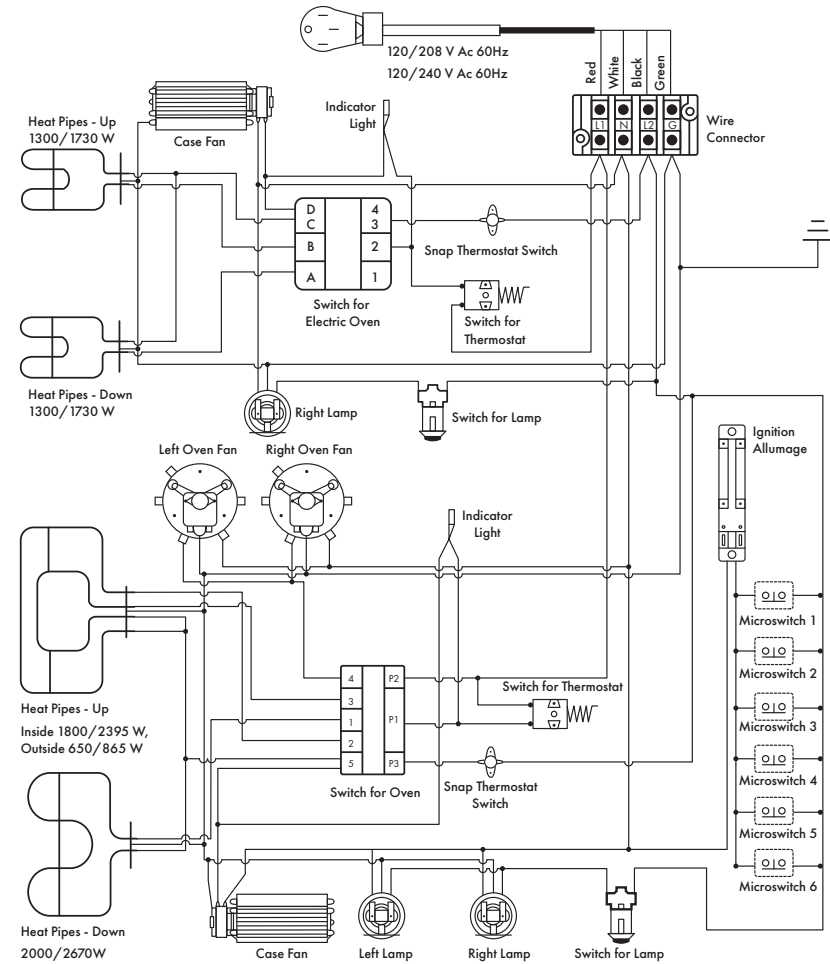

CAUTION: Connect the red wire to the L1 tab (left), the black wire to the L2 tab (right), the white wire to the N tab (central), and the yellow and green wire to the ground screw. DO NOT SWAP CONNECTIONS.

GAS CONNECTION

All gas connections must comply with national and local codes. The gas supply line (service) must be the same size or greater than the inlet line of the appliance. This range uses a 1/2" NPT inlet. Use appropriate sealant on all pipe joints that are resistant to gas.

This range can be used with Natural or LP/propane gas. The range is shipped from the factory for use with natural gas.

For LP/Propane household installation, the appliance must be converted by the dealer, factory-trained professional, or qualified licensed plumber or gas service company.

Gas conversion is important for safe and effective use of the appliance. It is the responsibility of the dealer and the owner of the range to perform the appropriate gas conversion following the directions of the manufacturer.

The gas conversion procedure is described in this manual and in the package containing the conversion nozzles shipped with every range.

Please provide the service person with this manual before work is started on the range.



DO NOT use an open flame when checking for leaks.

Leak testing of the appliance shall be conducted according to the manufacturer's instructions. Before placing the oven into operation, always check for leaks with soapy water solution or other acceptable method. Check for gas leakage with soapy water solutions on all gas connections between inlet gas pipes of the appliance, the gas regulator and, the manual shut-off valve. Bubbles will form with a soapy water solution if there is a leak.

GAS CONNECTION

Manual Shut-Off Valve

This valve is not shipped with the appliance and must be provided by the installer. The manual shut-off valve must be installed in the gas service line between the gas hook-up on the wall and the appliance inlet, in position where it can be reached quickly in the event of an emergency.

In Massachusetts: A T handle type manual gas shut-off valve must be installed in the gas supply line to this appliance.

Flexible Connections

In case of installation with flexible couplings and/or quick-disconnect fittings, the installer must use a heavy duty, AGA design-certified commercial flexible connector of at least 1/2" (1.3cm) IF NPT (with a suitable strain relief in compliance with ANSI Z21.41 and Z21.69 standards).

In Massachusetts: The unit must be installed with a 36" (3 foot long) flexible gas connector.

In Canada: Use CAN 1-6. 10-88 metal connectors for gas appliances and CAN 1-6.9 M79 quick disconnect device for use with gas fuel.

Pressure Test Point Stopper Valve

To avoid gas leaks, the pressure test-point stopper valve and gasket supplied with the range must be installed on the gas fitting at the back of the range according to the diagram below.

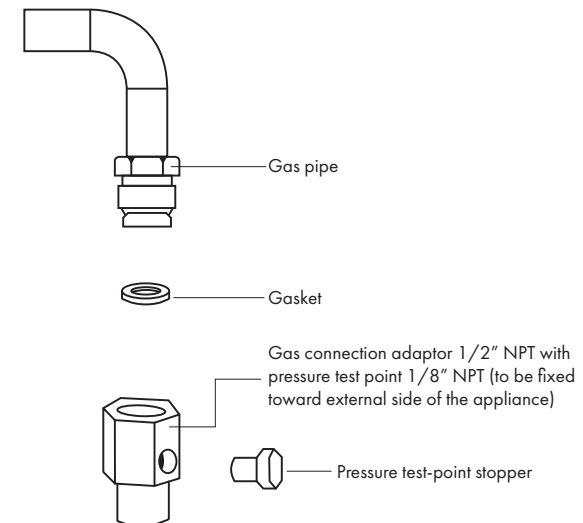

GAS CONNECTION

Pressure Regulator

Since service pressure may fluctuate with local demand, every gas cooking appliance must be equipped with a pressure regulator on the incoming service line for safe and efficient operation.

PRESSURE REGULATOR

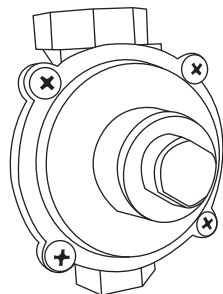

The pressure regulator shipped with the appliance has two female threads 3/4" NPT. The regulator shall be installed properly in order to be accessible when the appliance is installed in its final position. Manifold pressure should be checked with a manometer and comply with the values indicated below.

- Natural Gas->430" W.c.P
- L P/Propane-> 10.0" W.c.P

Incoming line pressure upstream from the regulator must be 1" W.C.P. higher than the manifold pressure in order to check the regulator.

The regulator used on this range can withstand a maximum input pressure of 1/2 PSI (13.8" W.C or 3.5kPa) If the line pressure exceeds that amount, a step down regulator is required.

The appliance, its individual shut-off valve, and the pressure regulator must be disconnected from the gas line during any pressure testing of that system at pressures in excess of 1/2 PSI (13.8" W.c or 3.5kPa).

Before carrying out this operation, disconnect the appliance from gas and electricity.



Gas conversion shall be conducted by a factory-trained professional.

GAS CONVERSION PROCEDURE

The gas conversion procedure for this range includes:

1. Pressure Regulator
2. Surface Burners
3. Flame Adjustment

The conversion is not finished if all steps are not completed.

Before performing the gas conversion, locate the package containing the replacement nozzles, which has a number indicating its flow diameter printed on the body. Consult the table below for matching nozzles to burners.

Save the nozzles removed from the range for future use.

Propane Conversion Video

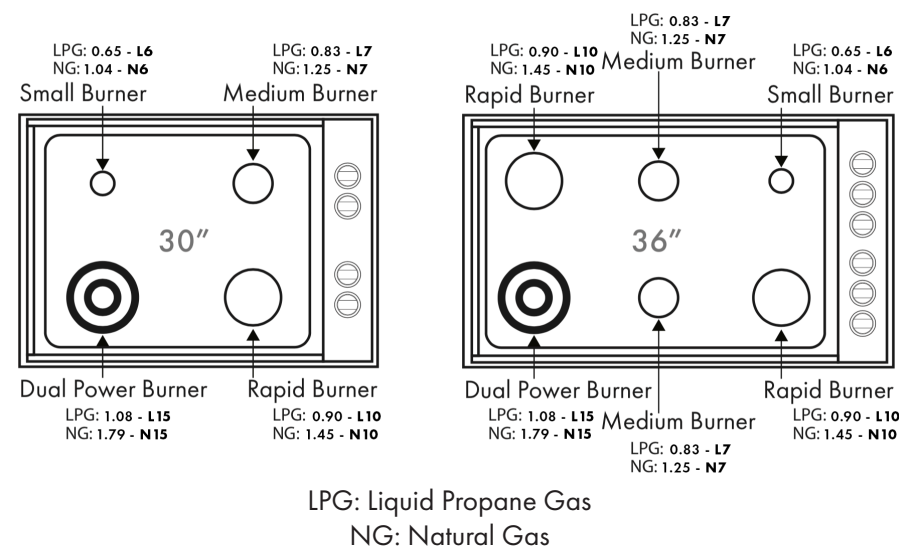

Note: The 48" cooktop is identical to the 36" except for a 7th burner for the griddle, with an LPG orifice size of 1.08 - L15

GAS CONVERSION PROCEDURE

Step 1: Pressure Regulator

The pressure regulator supplied with the appliance is a convertible type pressure regulator for use with Natural Gas at a nominal outlet pressure of 4" w.c. or LP gas at a nominal outlet pressure of 11" w.c. and it is pre-assembled from the factory to operate with one of these gas pressure as indicated in the labels affixed on the appliance, package and instruction booklet.

To convert the regulator for use with other liquid propane LP gas:

1. Unscrew the upper cap of the regulator, reverse its direction, and screw it in firmly against the cap.
2. Screw the metal cap, by hand, in the original position on the regulator.

GAS CONVERSION PROCEDURE

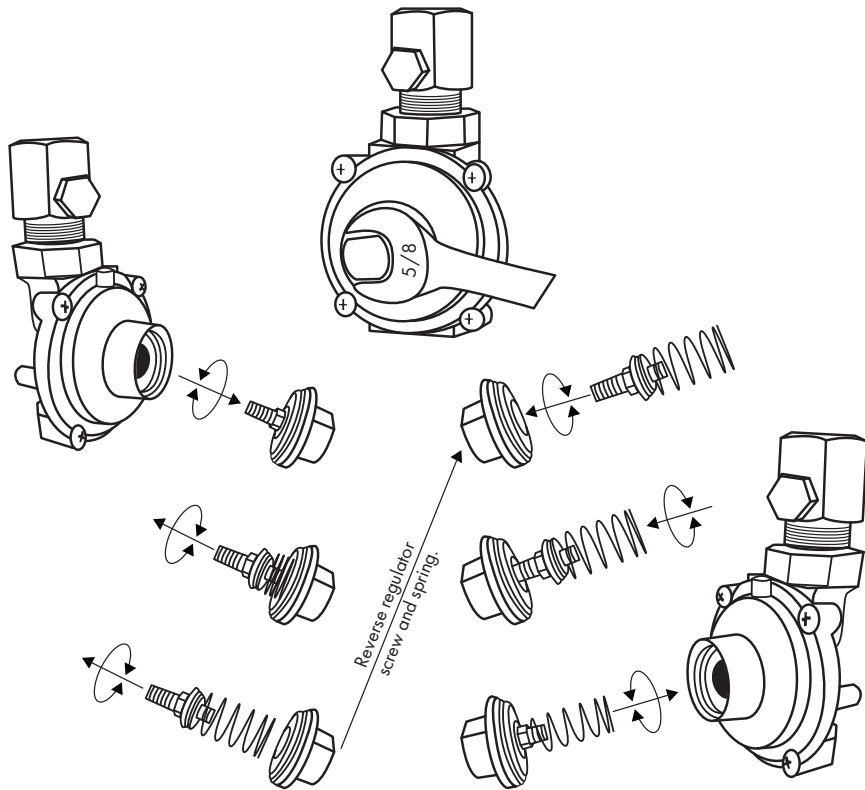

GAS CONVERSION PROCEDURE

Step 2: Surface Burners

To replace the nozzles of the surface burners, lift up the burners and unscrew the nozzles shipped with the range using a 7 mm (socket wrench).

Replace nozzles using the conversion set supplied with the range. Each nozzle has a number indicating its flow diameter printed on the body. Consult the table on page 18 for matching nozzles to burners.

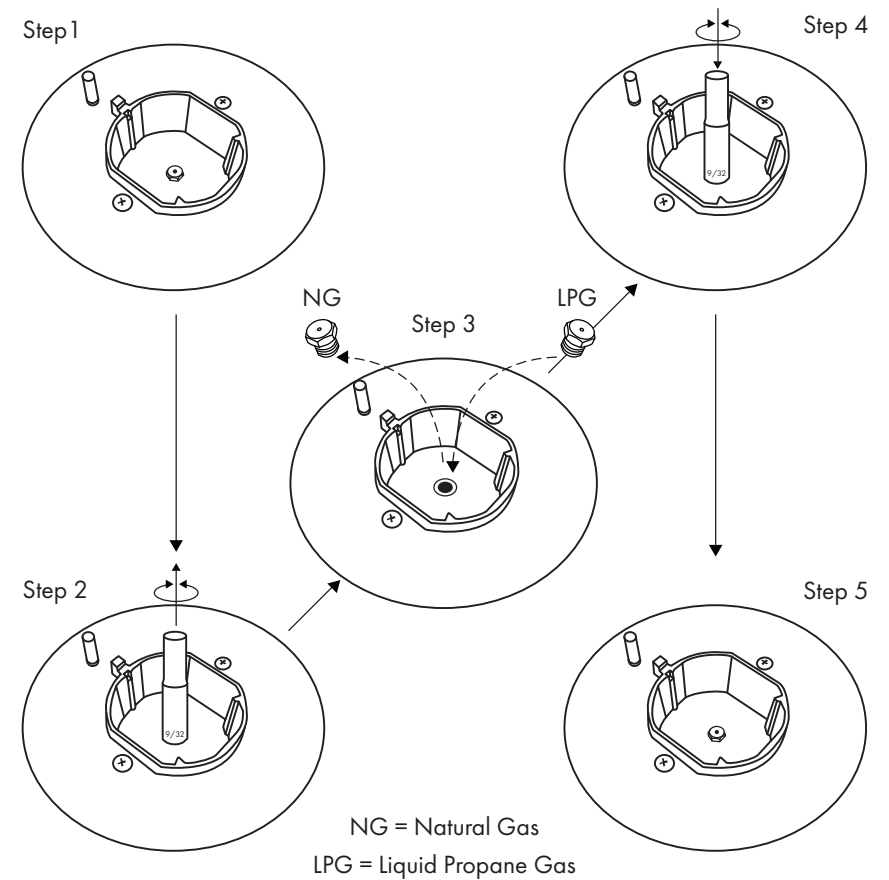

FLAME ADJUSTMENT PROCEDURE

1. Light one burner at a time and set it to the MINIMUM position (small flame).
2. Remove the knob.
3. The range is equipped with a safety valve. Using a small-size slotted screwdriver, locate the choke screw (see diagram below) and turn to the right or left until the burner flame is adjusted to desired minimum.
4. Make sure that the flame does not go out when switching quickly from the MAXIMUM TO THE MINIMUM position.

FLAME ADJUSTMENT

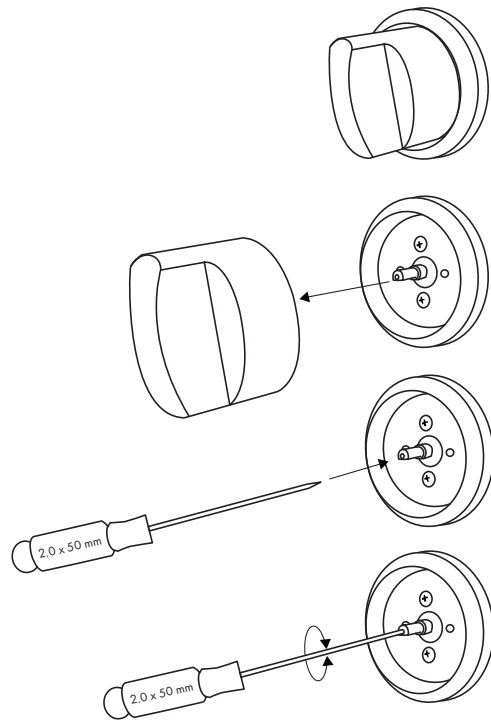

INSTALLATION CHECKLIST

1. Is the range mounted on its legs?
2. Is the back guard securely connected?
3. Has the anti-tip device been properly installed?
4. Does the clearance from the side cabinets comply with the manufacturers' direction?
5. Is the electricity properly grounded?
6. Is the gas service line connected following the directions of the manufacturer?
7. Have all the proper valves, stoppers, and gaskets been installed between the range and the service line?
8. Has the gas connection been checked for leaks?
9. Has the range been setup for the type of gas available in the household? (LP, propane, or natural gas)
10. Does the flame appear sharp blue with no yellow tipping?
11. Has the minimum setting for all burners been adjusted?

FINAL PREPARATION

All stainless steel body parts should be wiped with hot, soapy water and with a stainless steel cleanser.

If build-up occurs, do not use steel wool, abrasive cloths, cleaners, or powders. If it is necessary to scrape stainless steel to remove encrusted materials, soak with hot, wet cloths to loosen the material, and then use a wood or nylon scraper. DO NOT use a metal knife, or any other metal tool to scrape stainless steel! Scratches are almost impossible to remove.

Before using the oven for food preparation, clean thoroughly with a warm soap and water solution to remove film residues and any dust or debris from installation, then rinse and wipe dry.

ROOM VENTILATION



WARNING

Any child or adult can tip the range, verify the anti-tip device has been properly installed and engaged.

Ensure the anti-tip device is re-engaged when the range is moved.

Do not operate the range without the anti-tip device in place and engaged. Failure to do so can result in serious injury or serious burns to children or adults.

The use of a gas cooking appliance generates heat and humidity in the room where it is installed. Proper ventilation in the room is needed. Make sure the kitchen is equipped with a range hood of appropriate power (400 CFM minimum). Activate the exhaust fan/range hood when possible. Intensive and continuous use of the appliance may require additional ventilation, for example by opening a window.

SURFACE BURNER LAYOUT

SURFACE BURNER LAYOUT

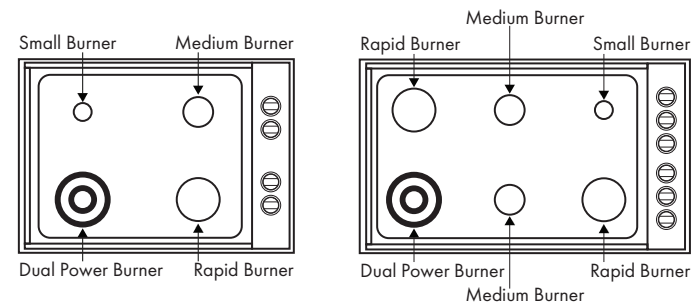
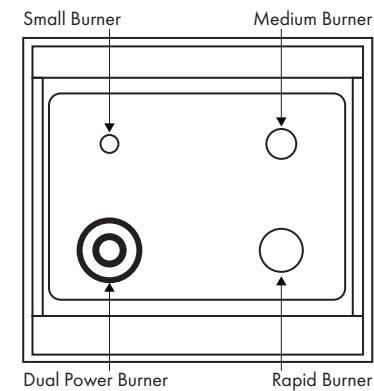

OVEN COOKING

Be sure to set all worktop/oven/broiler burner controls to the OFF position after each use of the appliance.

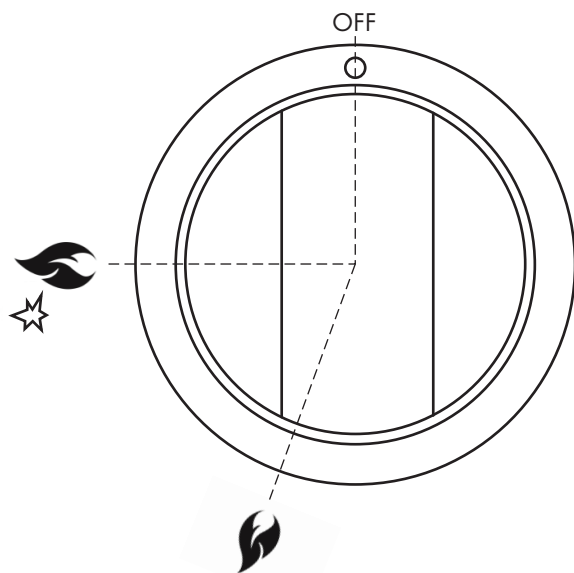

Maximum temperature setting/recommended control knob position for burner ignition.



Minimum Temperature Setting



Appliance with Worktop Gas Valves
Alternative Type

Note: When igniting a burner, all burners will spark, but only the burner's knob you are using will ignite the flame.

USING THE OVEN

Surface Burner Operation - Electric Ignition

To activate the electric ignition, simply turn the control knob counter-clockwise to maximum power (* position *), then press the knob in to start the flow of gas and the ignition spark. The spark will be re-released at the metal tip of the white ceramic pin located on the side of the burner. Once the flame is on, release the control knob gently. If the flame turns off, simply repeat the above procedure.



DO NOT ignite the burners if the black burner cap is not installed or not centered, the flame will be irregular.

Manual Ignition

Manual ignition is always possible even when the power is cut off, or in the event of a power failure. Turn the control knob counter-clockwise to the MAXIMUM position; light the flame with a kitchen lighter or with a match.

Using the Burners Correctly



Keep children at a safe distance from the appliance during operation. DO NOT allow children to operate the appliance!

1. Always check that the burner caps are properly installed before operation:

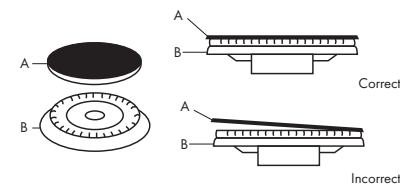

2. Verify that the flame of the worktop burners is completely blue and with a regular aspect as shown below:

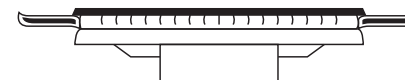

3. Always adjust the burner flame so it does not extend beyond the edge of the pan.

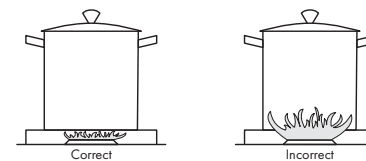

Using Pans Correctly

1. Always ensure that the bottom and handles of pans do not protrude over the worktop.
2. When cooking with flammable fat, such as oil, do not leave the range unattended.
3. Use pots of the appropriate size on each burner following the indication of the diagram below.
4. To avoid overflow when boiling liquids; turn knob to the minimum heat.
5. Always use pots with matching lids.
6. Dry the bottoms of pans before operation.
7. **Wok Cooking:** Always use the wok adapter supplied with the range. The wok pan's external diameter shall not be smaller than 10" and larger than 16".

Oven Cooking

1. Use care when opening door. Let hot air or steam escape before removing or placing food.
2. **DO NOT** heat unopened food containers. Pressure build-up may cause container to burst and result in injury.
3. Keep oven vent ducts unobstructed.

Placement of Oven Racks

1. Always place oven racks in desired location while oven is cool. If rack must be moved while oven is hot, **DO NOT** let potholder make contact with heating element in oven.
 2. **DO NOT CLEAN DOOR GASKETS.** The door gasket is essential for a good seal. Care should be taken not to rub, damage, or move the gasket.
 3. **DO NOT USE ABRASIVE OVEN CLEANERS.** No commercial oven cleaner or oven liner protective coating of any kind should be used in or around any part of the oven.
- Clean only the parts listed in the manual, before cleaning the oven, remove broiler pan and other utensils.
4. In case of electric power failure reset oven/broiler controls to the OFF position, do not attempt to use oven/ broiler until the power has been restored.

Placement of Oven Racks Continued

5. **DO NOT TOUCH HEATING ELEMENTS OR INTERIOR SURFACE OF OVEN.** Heating elements may be hot even though they are dark in color. Interior surfaces of an oven become hot enough to cause burns. During and after use, do not touch, or let clothing or other flammable materials come into contact with the heating elements or interior surfaces of the oven until they have had sufficient time to cool. Other surfaces of the appliance may become hot enough to cause burns, for example, oven vent openings and surfaces near these openings, oven doors, and oven glass window.
6. Take care to reset all worktop/oven/broiler burner controls to the OFF position after use of the appliance.

SYMBOLS: OVEN FUNCTIONS SELECTOR

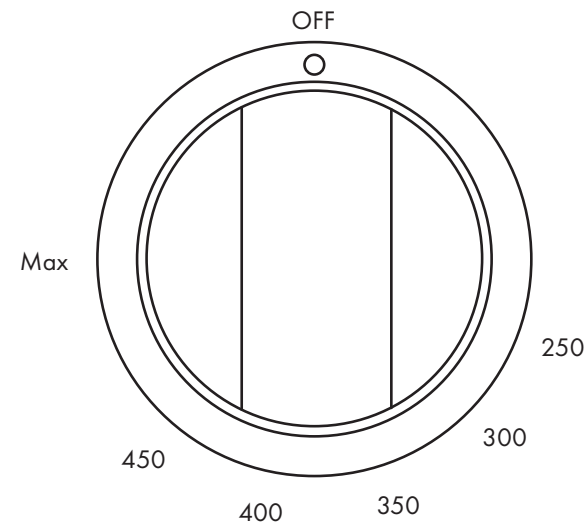

WARNING

To reduce the risk of tipping of the appliance, it must be secured with a properly installed anti-tip device. To check if the device is installed properly, remove the appliance from the wall and verify that the anti-tip device is engaged.

USING THE OVEN

Oven Racks

The ranges are equipped with commercial grade shelves and an enamel cooking tray. Shelves are mounted on the appropriate guides situated on the sides of the oven compartment. Insert the shelf between the top and bottom guide in any of the 5 positions available.

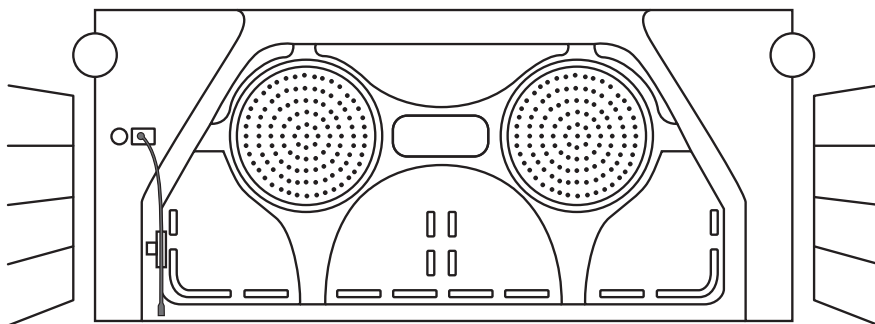

To keep the oven as clean as possible, cook on the tray.

When available, always follow recipe book directions. Personal experience will help to determine any variation in the values reported in the table. In any case, it is recommended to follow the instructions of the specific recipe being used.



WARNING

When using the oven for the first time it should be operated for 15-30 minutes at a temperature of about 500°F/260°C without cooking anything inside in order to eliminate any moisture and odors from the internal insulation.

Note: if you have a griddle, you may want to clean it but it does not need to be seasoned before use.

USING THE OVEN

High Bake/Preheat: This setting is the optimum setting for roasting and baking, suggested use if for baking at temperatures 300-525 degrees. High Bake will use both the bottom element and the top element for even cooking and optimal oven temperatures. Use this setting for preheating the oven- High Bake is designed to get the oven to optimal temperature as quickly as possible. After the oven reaches desired temperature, you can leave on this setting for optimal heat, or adjust accordingly to convection bake, bake, convection broil, or broil.

Bake/ Low Bake: Utilizing only the bottom element, this setting is designed for low heat settings under 375 degrees for optimal results.

Convection Bake: Utilizing both the bottom heating element and convection fan this setting is recommended for all temperatures up to 450 degrees. For most baking applications and recipes, this setting is recommended for a faster and more even cooking experience.

Broil: This setting uses only the top heating element.

Convection Broil: This setting uses both the top heating element and the convection fan. For most broiling applications and recipes, this setting is recommended for a faster and more even cooking experience.

MAINTAINING YOUR RANGE

Replacing the Oven Bulbs



WARNING

Disconnect the power before servicing the unit.

To replace the oven light bulb, unscrew the protection cap that projects out inside the oven. Note: Touching the bulb with your fingers may cause the bulb to burn out. Always use protective gloves or a clean cloth to remove the bulb.

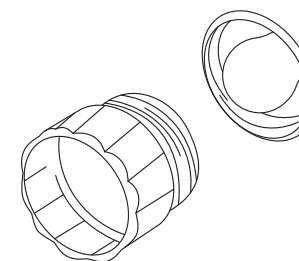

Cleaning Your Range



WARNING

During cleaning operation never move the appliance from its original installation position. Never use abrasive cleaners! Scratches on the stainless steel surfaces are permanent. Do NOT clean the range when hot!

Cleaning after Installation: Use a stainless steel cleaning product or wipe to eliminate the glue residues of the blue protection film after removal.

Cleaning the Worktop: Periodically clean the burner heads, the cast iron pan supports, and the burner caps using warm water. Remove burner food and fat residues with a rubber spatula.

Cleaning Stainless Steel: For the best results use a stainless steel cleaner product with a soft sponge or cloth with a warm soap and water solution. Never use abrasive powders or liquids.

Cleaning the Burner Caps: Lift the burner caps from the burner heads and wash them in a warm soap and water solution. Dry thoroughly before using them again. Before reinstalling them on the burner head, check that the gas flow holes are not clogged with food residues or cleaning products.

Cleaning Enamel: Enameled parts should be cleaned frequently with warm soap and water solution applied with a soft sponge or wipe. Never use abrasive powders or liquids! Do not leave acid or alkaline substances on the enameled parts (such as vinegar, lemon juice, salt, tomato sauce etc.) Use a rubber spatula to remove fat residues.

Cleaning Glass Door: Clean the glass using a non-abrasive sponge or wipe with a warm soap and water solution. Use a rubber spatula to remove fat deposits.

Oven Problem	Possible Cause and/or Remedy
Range does not function	Range is not connected to electrical power. Check power circuit breaker, wiring, and fuses.
Broil does not work	Temperature control knob is rotated too far past broil position (500°F); preheating indicator will light intermittently.
Door does not open	Oven is still in self-clean mode. Door latch will release when a safe temperature is reached.
Igniter does not work	The circuit is tripped, fuse is blown, or range is not connected to power.
Igniter sparking taut; No flame ignition	Gas supply valve is in the "OFF" position or gas supply is interrupted.
Burner ignites but flame is large, distorted, or yellow	Burner ports are clogged or the unit is not set to the appropriate gas type. Call a technician to repair.
Oven door is locked and will not release, even after cooling.	Turn the oven off at the circuit breaker and wait 5 minutes. Turn the breaker back on and the oven will reset itself.
Oven is not heating	Check the circuit breaker or fuse box to your house. Make sure there is proper electrical power to your oven.
Oven light is not working properly	Replace or reinsert the light bulb if loose or defective.
Oven light stays on	Check for obstruction in the oven door. Check to see if hinge is bent.
Cannot remove lens cover on light	There may be soil or build up on the lens cover. Wipe the lens cover with a clean, dry towel prior to attempting to remove the lens cover.



Thank you for joining
the ZLINE family



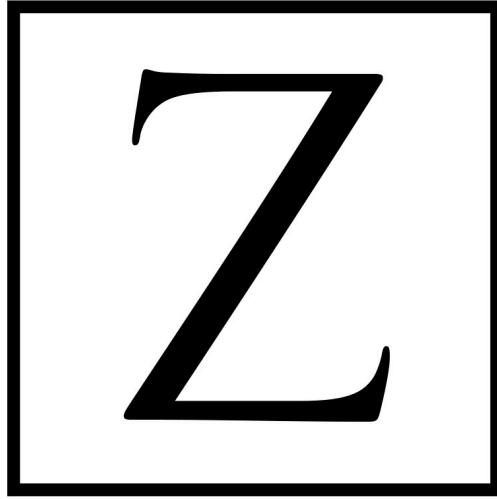

ZLINE
KITCHEN AND BATH

Two Locations:

916 Delaware Avenue
Marysville, Ohio 43040

350 Parr Circle
Reno, NV 89512

www.zlinekitchen.com

1-614-777-5004