



USER GUIDE & INSTALLATION INSTRUCTIONS

Professional + FXP 90 Dual Fuel
Australia

U111316-01

Contents

1. Before You Start...	1	9. Installation	26
Personal Safety	1	Safety Requirements and Regulations	26
Electrical Connection Safety	2	Provision of Ventilation	26
If You Smell Gas	2	Location of Cooker	26
Peculiar Smells	2	Conversion	26
Cooling Fan	2	Positioning the Cooker	28
Ventilation	3	Moving the Cooker	29
Maintenance	3	Removing the Oven Door	29
Cooker Care	5	Lowering the Two Rear Rollers	29
2. Overview	7	Completing the Move	29
Hotplate burners	7	Levelling	30
Wok burner	8	Fitting the Stability Bracket and Chain	30
The wok cradle	8	Fitting a Stability Bracket	30
Griddle	9	Fitting the Restraining Chain	30
Multifunction oven	10	Gas Connection	31
Energy saving panel	12	Pressure Testing	31
Operating the oven	12	Electrical Connection	31
Accessories	13	Fixed Wiring	32
3. 6 Button clock	14	Final Checks	32
4. Cooking tips	16	Final Fitting	33
5. Cooking Table	17	Customer Care	33
6. Cleaning your cooker	18	Fitting the drawer	34
7. Troubleshooting	23	Removing the drawer	34
8. Service and Spares	25	10. Conversion to propane gas	35
		Conversion from Natural Gas (1.0 kPa) to LPG X	
		Propane (2.54 kPa)	35
		Injectors	35
		Tap adjustment	35
		Set the governor	36
		Pressure testing	36
		Affix label	36
		11. Servicing	37
		1. Panels	37
		2. Hotplate	38
		3. Controls	38
		4. Ovens	39
		5. Door	42
		12. Circuit Diagram	44
		13. Technical Data	45

1. Before You Start...

Your cooker should give you many years of trouble-free cooking if installed and operated correctly. It is important that you read this section before you start.

Personal Safety

This appliance is for cooking purposes only. It must not be used for other purposes, for example heating a room. Using it for any other purpose could invalidate any warranty or liability claim. Besides invalidating claims this wastes fuel and may overheat the control knobs.

This cooker must be installed in accordance with the relevant instructions in this booklet and with the national and local regulations as well as the local gas and electricity supply companies' requirements.

- This appliance can be used by children aged from 8 years and above and persons with reduced physical, sensory or mental capabilities or lack of experience and knowledge if they have been given supervision or instruction concerning use of the appliance in a safe way and understand the hazards involved.
- **WARNING:** Children **less** than 8 years of age should be kept away unless continuously supervised. Children shall not play with the appliance. Cleaning and user maintenance shall not be made by children without supervision.
- Suitable only for indoor installation.
- **DO NOT** operate this appliance before reading the instruction booklet.
- **DO NOT** place articles on or against this appliance.
- **DO NOT** operate with panels, covers or guards removed from this appliance.
- The cooker should not be placed on a base.
- This appliance is designed for domestic cooking only. Use for any other purpose could invalidate any warranty or liability claim.
- Before operating the ovens please refer to the oven shelf installation, in the Accessories section.
- **WARNING:** The appliance and its accessible parts become hot during use and will retain heat even after you have stopped cooking. Care should be taken to avoid touching heating elements. Children less than 8 years of age shall be kept away unless continuously supervised.
- **CAUTION:** A long term cooking process has to be supervised from time to time. A short term cooking process has to be supervised continuously.
- At the risk of fire **DO NOT** store items on the cooking surfaces.
- **DO NOT** install an aftermarket lid or cover over this appliance.
- **DO NOT** install combustible bench top lids or covers within 200 mm (7 7/8") of the nearest burner.
- To avoid overheating, **DO NOT** install the cooker behind a decorative door.
- **WARNING:** Accessible parts will become hot during use and will retain heat even after you have stopped cooking. Keep babies and children away from the cooker and never wear loose-fitting or hanging clothes when using the appliance.
- **DO NOT** use a steam cleaner on your cooker.
- Always keep combustible materials, e.g. curtains, and flammable liquids a safe distance away from the cooker.

- **DO NOT** spray aerosols in the vicinity of the cooker while it is on.

Electrical Connection Safety

⚠ WARNING: THE APPLIANCE MUST BE EARTHED.

The cooker is preset for a single-phase earthed electrical connection. It is essential to install a multi-pole circuit breaker that completely disconnects the appliance from the mains, with a minimum contact break distance of 3 mm.

The total electrical load of the appliance is approximately 3.6 kW. The cable size used should be suitable for this load and comply with all local requirements (i.e. PVC Insulated cable IEC 60227 – code 53 for ordinary cables).

Minimum temperature rating T105.

Read the instructions before installing or using this appliance.

Gas Connection Safety

- This cooker is a Class 2 Subclass 1 appliance.
- This appliance can be converted for use on another gas.
- Before installation, make sure that the cooker is suitable for your gas type and supply voltage. See the data badge.
- **DO NOT** use reconditioned or unauthorised gas controls.
- Disconnect from the electricity and gas supply before servicing.
- When servicing or replacing gas-carrying components disconnect from the gas supply before starting operation. Check the appliance is gas sound after completion.
- Make sure that the gas supply is turned on and that the cooker is wired in and switched on.

- In your own interest and that of safety, it is law that all gas appliances be installed by a qualified person(s).
- An appliance for use on LPG must not be installed in a room or internal space below ground level, e.g. in a basement.

If You Smell Gas

- **DO NOT** turn electric switches on or off
- **DO NOT** smoke
- **DO NOT** use naked flames
- Turn off the gas at the meter or cylinder
- Open doors and windows to get rid of the gas
- Keep people away from the area affected
- Call your gas supplier

Peculiar Smells

When you first use your cooker it may give off an odour. This should stop after use.

Before using for the first time, make sure that all packing materials have been removed and then, to dispel manufacturing odours, turn the ovens to 200 °C and run for at least an hour.

Before using the grill for the first time you should also turn on the grill and run for 30 minutes with the grill pan in position, pushed fully back and the grill door open.

Make sure the room is well ventilated to the outside air (see 'Ventilation' below). People with respiratory or allergy problems should vacate the area for this brief period.

Cooling Fan

This appliance may have a cooling fan. When the grill or ovens are in operation the fan will run to cool the fascia and control knobs.

Ventilation

The use of a cooking appliance results in the production of heat and moisture in the room in which it is installed. Therefore, make sure that the kitchen is well ventilated: keep natural ventilation holes open or install a powered cookerhood that vents outside. If you have several hotplates/burners on, or use the cooker for a long time, open a window or turn on an extractor fan

Maintenance

- It is recommended that this appliance is serviced annually.
 - **WARNING:** Before replacing the oven lamp, turn off the power supply and make sure that the oven is cool.
 - **DO NOT** use cooking vessels on the hotplate that overlap the edges.
 - Unless specified otherwise in this guide, always allow the cooker to cool and then switch it off at the mains before cleaning or carrying out any maintenance work.
 - **DO NOT** use the control knobs to manoeuvre the cooker.
 - **NEVER** operate the cooker with wet hands.
 - **DO NOT** use a towel or other bulky cloth in place of a glove – it might catch fire if brought into contact with a hot surface.
 - **DO NOT** use hotplate protectors, foil or hotplate covers of any description. These may affect the safe use of your hotplate burners and are potentially hazardous to health.
 - **NEVER** heat unopened food containers. Pressure build up may make the containers burst and cause injury.
 - **DO NOT** use unstable saucepans. Always make sure that you position the handles away from the edge of the hotplate.
 - **NEVER** leave the hotplate unattended at high heat settings. Pans boiling over can cause smoking, and greasy spills may catch on fire. Use a deep fat thermometer whenever possible to prevent fat overheating beyond the smoking point.
- ⚠ WARNING: Unattended cooking on a hob with fat or oil can be dangerous and may result in fire.**
- ⚠ NEVER** try to extinguish a fire with water, but switch off the appliance and then cover the flame e.g. with a lid or a fire blanket.
- **NEVER** leave a chip pan unattended. Always heat fat slowly, and watch as it heats. Deep fry pans should be only one third full of fat.
 - **WARNING: Danger of fire: do not store items on the cooking surfaces.**
 - **NEVER** try to move a pan of hot fat, especially a deep fat fryer. Wait until the fat is cool. Filling the pan too full of fat can cause spill over when food is added. If you use a combination of oils or fats in frying, stir them together before heating, or as the fats melt.
 - Foods for frying should be as dry as possible. Frost on frozen foods or moisture on fresh foods can cause hot fat to bubble up and over the sides of the pan. Carefully watch for spills or overheating of foods when frying at high or medium high temperatures.
 - **DO NOT** use the top of the flue (the slot along the back of the cooker) for warming plates, dishes, drying tea towels or softening butter.

Fig. 1.1

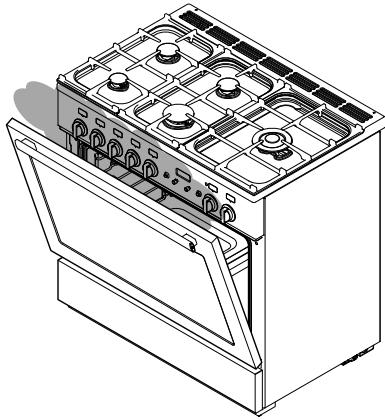
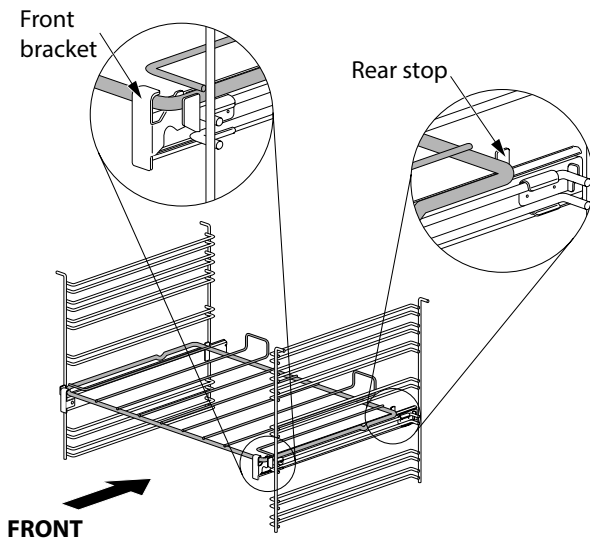

Fig. 1.2



- **DO NOT** use water on grease fires and never pick up a flaming pan. Turn the controls off and then smother a flaming pan on a surface unit by covering the pan completely with a well fitting lid or baking tray. If available, use a multi-purpose dry chemical or foam-type fire extinguisher.
- **DO NOT** modify this appliance. This appliance is not intended to be operated by means of external timer or separated remote-control system.
- If flammable materials are stored in the drawer, oven(s) or grill(s) it may explode and result in fire or property damage.

Oven Care

- When the oven is not in use and before attempting to clean the cooker always be certain that the control knobs are in the **OFF** position.
- Use oven gloves to protect your hand from potential burns.
- Cooking high moisture content foods can create a 'steam burst' when the oven door is opened (**Fig. 1.1**). When opening the oven, stand well back and allow any steam to disperse.
- The inside door face is constructed with toughened safety glass. Take care **NOT** to scratch the surface when cleaning the glass panel.
- Accidental damage may cause the door glass panel to fracture.
- Keep oven vent ducts unobstructed.
- **DO NOT** use harsh abrasive cleaners or sharp metal scrapers to clean the oven door glass since they can scratch the surface, which may result in shattering of the glass.
- Make sure the shelves are pushed firmly to the back of the oven. **DO NOT** close the door against the oven shelves.

- **DO NOT** use aluminium foil to cover shelves, linings or the oven roof.
- When the oven is on, **DO NOT** leave the oven door open for longer than necessary, otherwise the control knobs may become very hot.
- **DO NOT** use the timed oven if the adjoining oven is already warm.
- **DO NOT** place warm food in the oven to be timed.
- **DO NOT** use a timed oven that is already warm.
- Use dry oven gloves when applicable – using damp gloves might result in steam burns when you touch a hot surface.

Oven Shelves (dependant on model)

To fit the glide-out shelf, hook the front of the shelf onto the runners as shown (**Fig. 1.2**). The rear of the shelf should rest on the runners, in front of the rear stop (**Fig. 1.2**).

Standard oven shelves can be fitted by lining up the shelf with a groove in the oven ladders. Push the shelf back until the ends hit the shelf stop. Lift the front so the shelf clears the stops, then lower the front so the shelf is level and push it fully back.

Cooker Care

As steam can condense to water droplets on the cool outer trim of the oven, it may be necessary during cooking to wipe away any moisture with a soft cloth. This will also help to prevent soiling and discolouration of the oven exterior by cooking vapours.

Self-Clean Oven

- **WARNING:** Remove all cookware, shelves, and the shelf supports from the oven before using the self-clean function.
- **WARNING:** Using the self-cleaning function results in higher temperatures than those for normal cooking. Under such conditions the surfaces may get hotter than usual so children should be kept away.
- Pre-clean any areas that are not reached by the self-clean cycle, such as the outer edges of the oven door. Wipe up any excess fat or liquids.

Cleaning

- Isolate the electricity supply before carrying out any thorough cleaning. Allow the cooker to cool.
- In the interests of hygiene and safety, the cooker should be kept clean at all times as a build up in fats and other food stuff could result in a fire.
- Clean only the parts listed in this guide.
- Clean with caution. If a wet sponge or cloth is used to wipe spills on a hot surface, be careful to avoid steam burns. Some cleaners can produce noxious fumes if applied to a hot surface.
- **NEVER** use paint solvents, washing soda, caustic cleaners, biological powders, bleach, chlorine based bleach cleaners, coarse abrasives or salt.
- **DO NOT** mix different cleaning products – they may react together with hazardous results.
- All parts of the cooker can be cleaned with hot soapy water.
- Take care that no water seeps into the appliance.

- Before you remove any of the grill parts for cleaning, make sure that they are cool or use oven gloves.
- **DO NOT** use any abrasive substances on the grill and grill parts.
- **DO NOT** put the side runners in a dishwasher.
- **DO NOT** put the burner heads in a dishwasher.
- **NEVER** use caustic or abrasive cleaners as these will damage the surface.
- **DO NOT** use steel wool, oven cleaning pads or any other materials that will scratch the surface.
- **NEVER** store flammable materials in the drawer. This includes paper, plastic and cloth items, such as cookbooks, plastic ware and towels, as well as flammable liquids.
- **DO NOT** store explosives, such as aerosol cans, on or near the appliance.
- **DO NOT** use steel wool, oven cleaning pads, or any other materials that will scratch the surface.
- **DO NOT** attempt to disassemble or clean around any burner while another burner is on, otherwise an electric shock could result.

2. Overview



The dual fuel single cavity cooker (Fig. 2.1) has the following features:

- A. 5 hotplate burners including a wok burner
- B. Control panel incorporating a timer
- C. Multifunction oven
- D. Storage drawer

Hotplate burners

The drawing by each of the control knobs indicates which burner that knob controls.

Each burner has a special Flame Supervision Device (FSD) that prevents the flow of gas if the flame goes out.

When a hotplate control knob is pressed in, sparks will be made at every burner – this is normal. **DO NOT** attempt to disassemble or clean around any burner while another burner is on, otherwise an electric shock could result.

To light a burner, push in and turn the associated control knob to the high position as indicated by the large flame symbol (🔥), (Fig. 2.2).

The igniter should spark and light the gas. Keep holding the knob pressed in to let the gas through to the burner for about ten seconds.

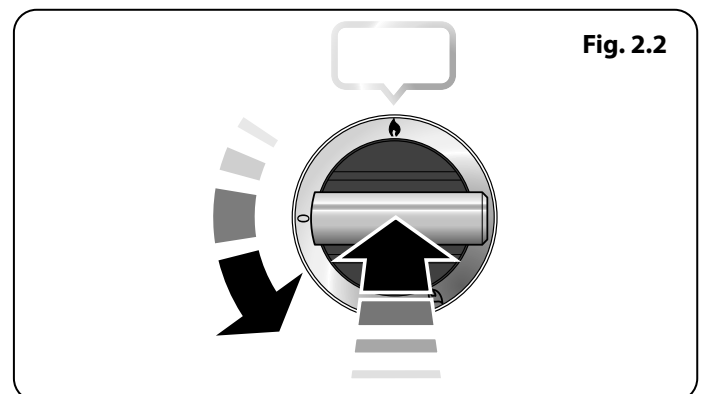
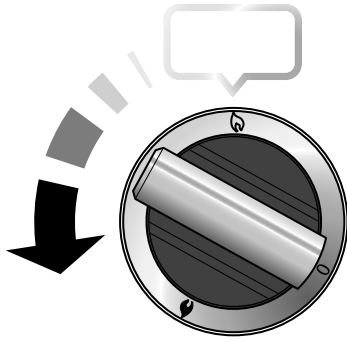

Fig. 2.3



If, when you let go of the control knob, the burner goes out, then the FSD has not been bypassed. Turn the control knob to the OFF position and wait for one minute before you try again, this time making sure to hold in the control knob for slightly longer.

Adjust the flame height to suit by turning the knob counter-clockwise (**Fig. 2.3**).

If a burner flame goes out, turn off the control knob and leave it for one minute before relighting it.

Make sure that the flames are under the pans. For safety reasons, adjust the flames so that they do not extend beyond the edge of the cooking utensil. Using a lid will help the contents boil more quickly (**Fig. 2.4**).

Large pans should be spaced well apart.

Pans and kettles with concave bases or down-turned base rims should not be used (**Fig. 2.5**).

Simmering aids, such as asbestos or mesh mats, are NOT recommended (**Fig. 2.6**). They will reduce burner performance and could damage the pan supports.

You should also avoid using unstable and misshapen pans that may tilt easily, and pans with a very small base diameter, e.g. milk pans, single egg poachers (**Fig. 2.7**).

The minimum recommended pan diameter is 120 mm. The maximum allowable pan base diameter is 260 mm.

DO NOT use cooking vessels on the hotplate that overlap the edges.

Fig. 2.4

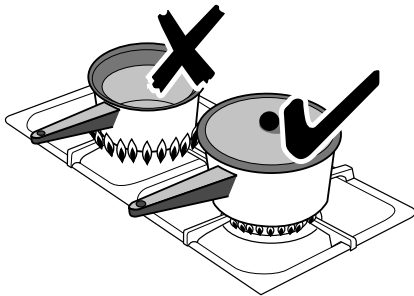

Fig. 2.5

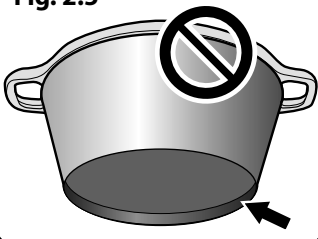

Fig. 2.6

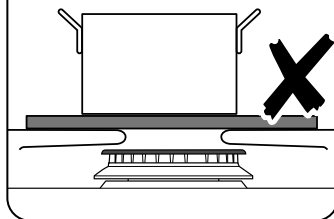

Fig. 2.7

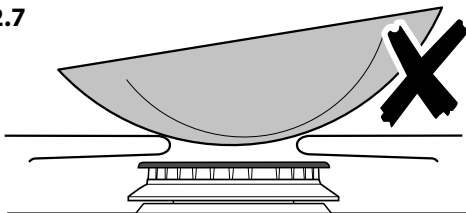

Fig. 2.8

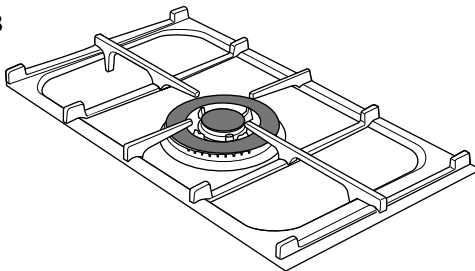
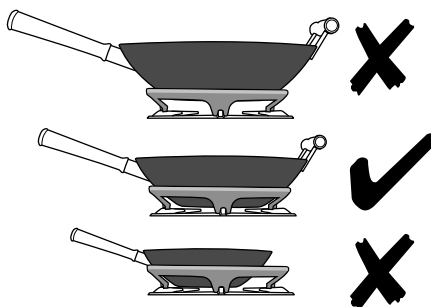

Fig. 2.9



Wok burner

The wok burner is designed to provide even heat over a large area. It is ideal for large pans and stir-frying (**Fig. 2.8**).

For heating smaller pans, the aforementioned hotplate burners may be more efficient.

You should wipe the enamel top surface of the cooker around the hotplate burners as soon as possible after spills occur. Try to wipe them off while the enamel is still warm.

NOTE: The use of aluminium pans may cause metallic marking of the pan supports. This does not affect the durability of the enamel and may be cleaned off with an appropriate metal cleaner.

The wok cradle

The wok cradle is designed to fit a 35 cm wok. If you use a different wok, make sure that it fits the cradle. Woks vary very widely in size and shape. It is important that the wok sits down on the pan support – however, if it is too small, the cradle will not support it properly (**Fig. 2.9**).

The cradle should be used on the wok burner only. When you fit the cradle, check that it is supported properly on a pan support and the wok is sitting level in the cradle (**Fig. 2.10**).

The cradle will get very hot in use – allow plenty of time for it to cool before you pick it up.

Griddle

The griddle fits the left-hand well, front to back (Fig. 2.11). It is designed for cooking food on directly. **DO NOT** use pans of any kind on it. The griddle surface is non-stick and metal cooking utensils (e.g. spatulas) will damage the surface. Use heat resistant plastic or wooden utensils.

⚠ DO NOT put it crossways – it will not fit properly and will be unstable.

⚠ DO NOT put it on any other burner – it is not designed to fit in any of the other cooker wells.

Remove the left-hand pan support. Position the griddle over the well. Check that it is securely located.

The griddle can be lightly brushed with cooking oil before use. Light the hotplate burners. Adjust the flame heights to suit.

Preheat the griddle for a **maximum of 5 minutes** before adding food. Leaving it longer may cause damage. Turn the control knobs towards the low position, marked with the small flame symbol, to reduce the burner flames.

Always leave space around the griddle for the gases to escape.

After cooking, allow the griddle to cool before cleaning.

If the griddle is washed in a dishwasher then some dishwasher residue may appear on the back. This is normal and will not affect the performance of your griddle.

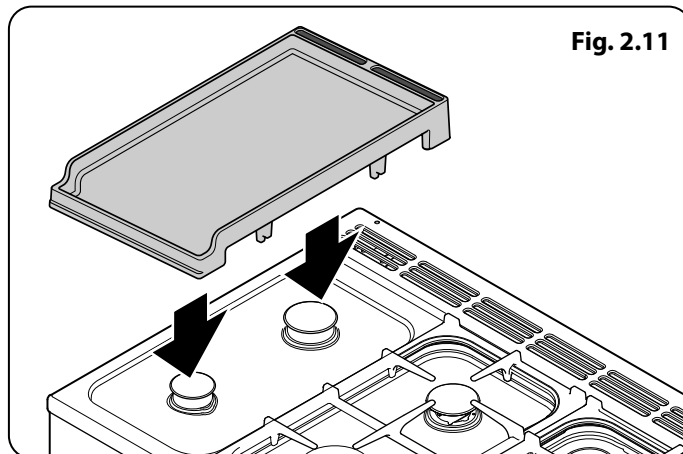
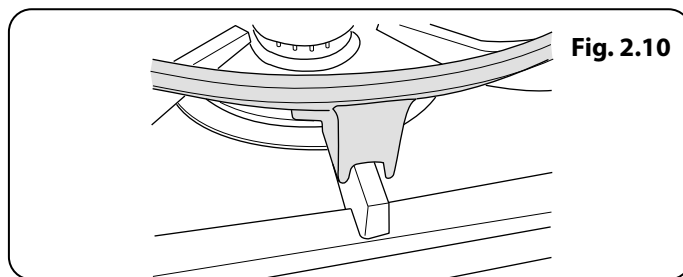

Multifunction oven

The oven is a multifunction oven (**Fig. 2.12**). In addition to convection elements around the fans, it is fitted with extra heating elements, in the top of the oven and under the oven base. Take care to avoid touching the top elements when placing or removing items from the oven.

The multi-function oven has 3 main cooking functions: **fan**, **fan assisted** and **conventional cooking**. These functions should be used to complete most of your cooking.

The **browning element** and **base heat** can be used in the latter part of the cooking process to fine tune the results to your particular requirements.

Use **fanned grilling** for all your grilling needs and **defrost** to safely thaw small items of frozen food.

Table 2.1 gives a summary of the multi-function modes. The multi-function oven has many varied uses. We suggest you keep a careful eye on your cooking until you are familiar with each function. Remember, not all functions will be suitable for all food types.

Multifunction oven modes (Fig. 2.13)

Defrost



This function operates the fan(s) to circulate cold air only. Make sure the temperature control is at 0°C and that no heat is applied. This enables small items such as desserts, cream cakes and pieces of meat, fish and poultry to be defrosted.

Defrosting in this way speeds up the process and protects the food from contamination. Pieces of meat, fish and poultry should be placed on a shelf, over a tray to catch any drips. Be sure to wash the shelf and tray after defrosting.

Defrost with the oven door closed. Defrosting should not be carried out in a warm oven. Large items, such as whole chickens and meat roasts should not be defrosted in this way. We recommend this be carried out in a refrigerator. Make sure that dairy foods, meat and poultry are completely defrosted before cooking.

Fan oven



This function operates the fans and the heating element around them. An even heat is produced throughout the oven, allowing you to cook large amounts quickly.

Fan oven cooking is particularly suitable for multi-shelf cooking and is a good 'all-round' function. It may be necessary to reduce the temperature by approximately 10°C for recipes previously cooked in a conventional oven.

If you wish to preheat the oven, wait until the indicator light has gone out before inserting the food.

Fig. 2.12

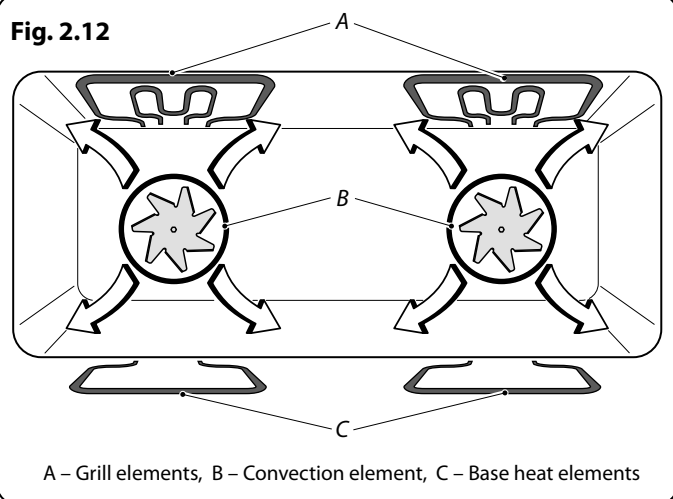

A – Grill elements, B – Convection element, C – Base heat elements

Function	Use
Defrost	To thaw small items in the oven without heat
Fan oven	A full cooking function, even heat throughout, great for baking
Fanned grilling	Grilling meat and fish with the door closed
Fan assisted	A full cooking function good for roasting and baking
Conventional oven	A full cooking function for roasting and baking in the lower half of the oven
Browning element	To brown and crisp cheese topped dishes
Base heat	To crisp up the bases of quiche, pizza or pastry
Self-Cleaning	To burn any cooking residue to ash

Table 2.1

Fanned grilling



This function operates the fan while the top element is on. It produces a more even, less fierce heat than a conventional grill. For best results place the food to be grilled on the pan provided. Thick pieces of meat or fish are ideal for cooking in this way, as the circulated air reduces the fierceness of the heat from the grill. The oven door should be kept closed while cooking is in progress, so saving energy. You will also find that the food needs to be watched and turned less than for normal grilling. Preheat this function before cooking.

NOTE: When grilling full width, to allow sufficient access for tending foods we recommend placing the grill pan tray support on the second from top level.

Fan assisted oven



This function operates the fans, circulating air heated by the elements at the top and the base of the oven. The combination of fan and conventional cooking (Top and Base Heat) makes this function ideal for cooking large items that need thorough cooking, such as a large meat roast. It is also possible to bake on two shelves at one time, although they will need to be changed over during the cooking time, as the heat at the top of the oven is greater than at the base, when using this function.

This is a fast intensive form of cooking; keep an eye on the food cooking until you are familiar with this function.

Conventional oven (Top and Base Heat)



This function combines the heat from the top and base elements. It is particularly suitable for roasting and baking pastry, cakes and biscuits.

Food cooked on the top shelf will brown and crisp faster than on the lower shelf, because the heat is greater at the top of the oven than at the base, as in 'Fan Assisted Oven' function. Similar items being cooked will need to be swapped around for even cooking. This means that foods requiring different temperatures can be cooked together, using the cooler zone in the lower half of the oven and hotter area to the top.

The exposed top element may cook some foods too quickly, so we recommend that the food be positioned in the lower half of the oven to cook. The oven temperature may also need to be lowered.

Browning element



This function uses the element in the top of the oven only. It is a useful function for the browning or finishing of pasta dishes, vegetables in sauce and lasagne, the item to be browned being already hot before switching to the top element.

Base heat



This function uses the base element only. It will crisp up your pizza or quiche base or finish off cooking the base of a pastry case on a lower shelf. It is also a gentle heat, good for slow cooking of casseroles in the middle of the oven or for plate warming.

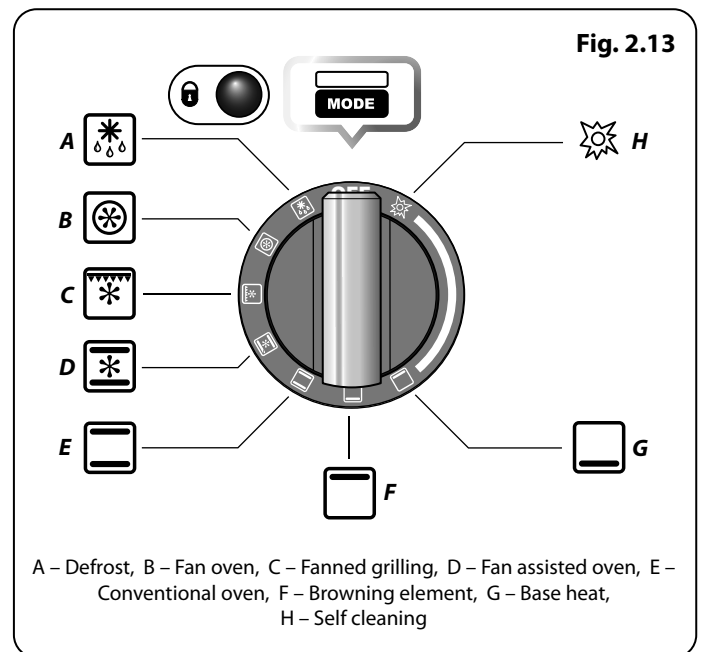

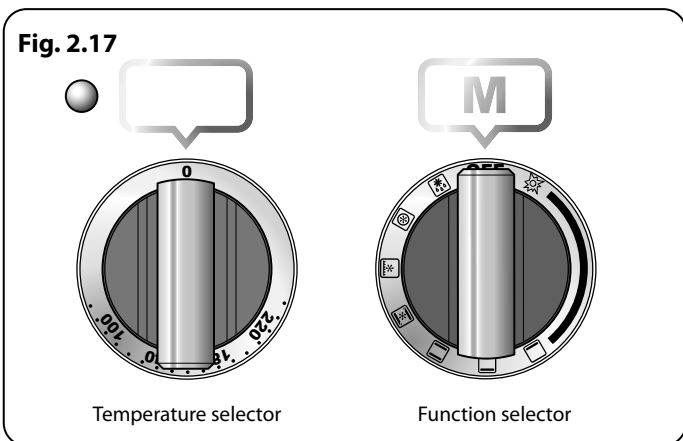
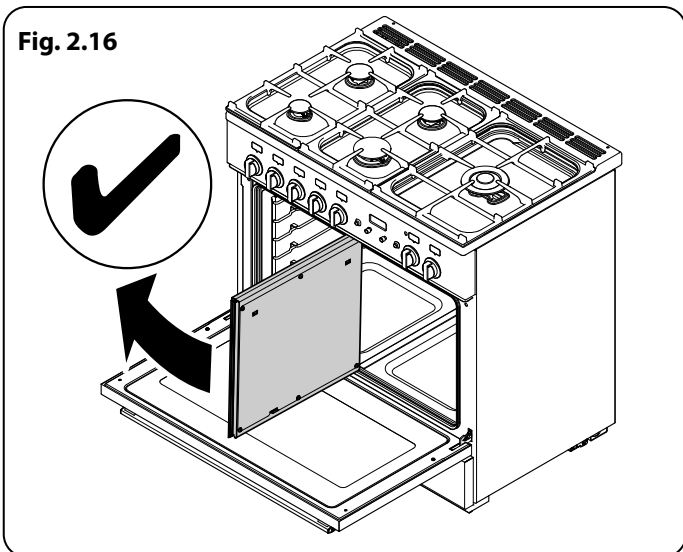
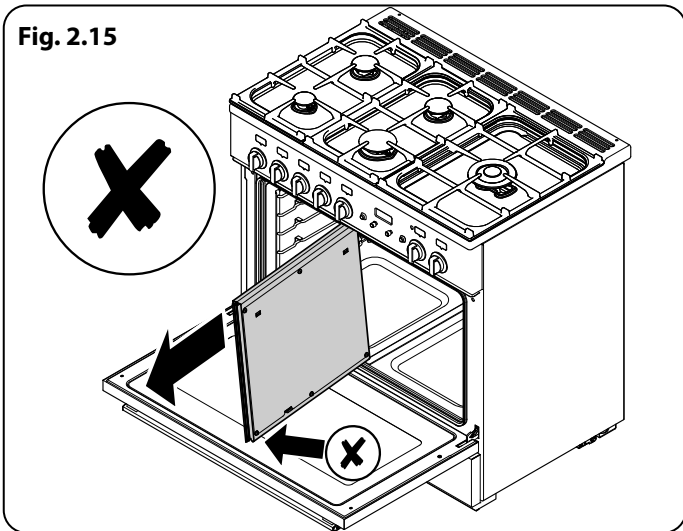
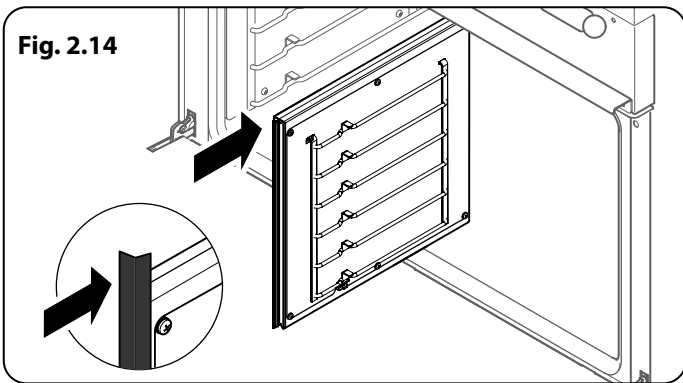

The Browning and Base Heat functions are useful additions to your oven, giving you flexibility to finish off items to perfection. With use, you will soon realize how these functions can combine to extend your cooking skills.

Self-cleaning



The oven has a self-cleaning function. The oven will run at a high temperature cycle to burn any cooking residue to ash that is easily cleaned away with a damp cloth. For safety, the oven will lock during the cleaning cycle.

See the 'Cleaning' section for further details on the self-cleaning operation.

Energy saving panel

The oven has a divider feature (**Fig. 2.14**). With this in place only one half of the oven is heated and only the right-hand side elements are used. This saves energy and is ideal for cooking most foods. When using the divider, condensation may appear in the left-hand oven – this is normal.

For very large loads, or large dishes for special occasions then the divider can be removed. This brings into use the elements on the left-hand side as well as those on the right when a function is selected.

All oven functions are available in full and divided forms and shelves are provided for use in both forms.

⚠ WARNING: Take great care when removing the divider not to scratch the inner glass door surface. Scratches in the glass can cause stress and may cause the door to fail.

Removing the divider

⚠ Make sure the cooker is cool before attempting to remove the divider.

Fully open the door and remove the oven shelves. When removing the divider, tilt it slightly upwards and grip the underside to prevent the metal base making contact with the door glass (**Fig. 2.15** and **Fig. 2.16**).

We recommend that you place a tea towel or similar on the door glass before removing the divider. This should prevent the door inner from scratching.

DO NOT place or slide metallic objects on the door glass as this may cause scratching and subsequent failure to occur.

Operating the oven

The multi-function oven has two controls: a function selector and a temperature setting knob (**Fig. 2.17**).

Turn the function selector control to a cooking function. **Fig. 2.18** shows the control set for convectional oven cooking.

Turn the oven temperature knob to the temperature you need. The oven heating light will glow until the oven has reached the temperature you selected. It will then cycle on and off during cooking as the oven maintains the selected temperature (**Fig. 2.19**).

Accessories

Each oven is supplied with:

- Two full capacity shelves (Fig. 2.20)
- Grill pan tray support (Fig. 2.23)
- Two grill pans with trivets (Fig. 2.21)
- Three energy saving shelves (Fig. 2.24)
- Four ladder shelf supports (Fig. 2.22)
- And one divider (Fig. 2.25)

Oven shelves

Any shelf can be fitted in any of the positions. The oven shelves are retained when pulled forward but can be easily removed and refitted.

To remove and refit the ladder shelf supports

Lift the ladder support hooks out of the two locating holes in the oven side (or divider) before lifting the support clear of the bottom ladder restraint.

Refit by inserting the bottom of the ladder into the restraint before fitting the hooks through the locating holes.

To remove and refit the shelves

Pull the shelf forwards until the back of the shelf is stopped by the shelf support (Fig. 2.26). Lift up the front of the shelf so the back of the shelf will pass between the supports and then pull the shelf forward (Fig. 2.27).

Refit in the reverse order, making sure to push it fully back.

Oven light

Press the button to turn on the oven lights (Fig. 2.28).

If one of the oven lights fail, turn off the cooker power supply before you change the bulb. See the 'Troubleshooting' section for details on how to change an oven light bulb.

Storage

The bottom drawer is for storing oven trays and other cooking utensils. The drawer can be removed completely for cleaning, etc.

- ⚠ **It can get very warm, so do not store anything in it that may melt or catch fire.**
- ⚠ **Never store flammable materials in the drawer. This includes paper, plastic and cloth items, such as cookbooks, plastic ware and towels, as well as flammable liquids.**
- ⚠ **Do not store explosives, such as aerosol cans, on or near the appliance.**
- ⚠ **Flammable materials may explode and result in fire or property damage.**

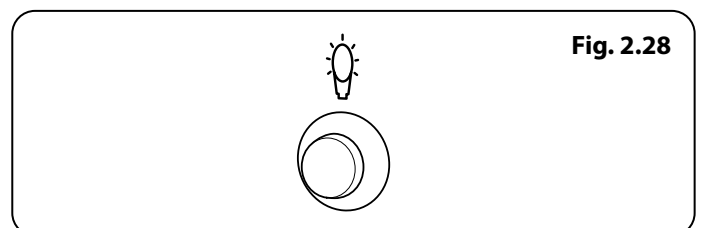
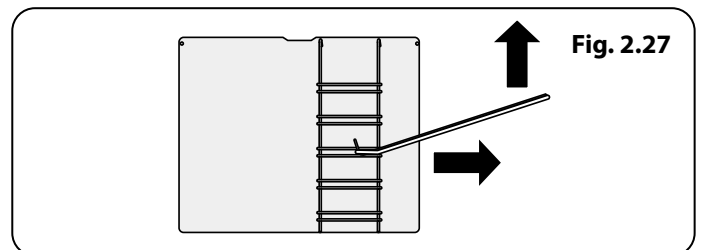
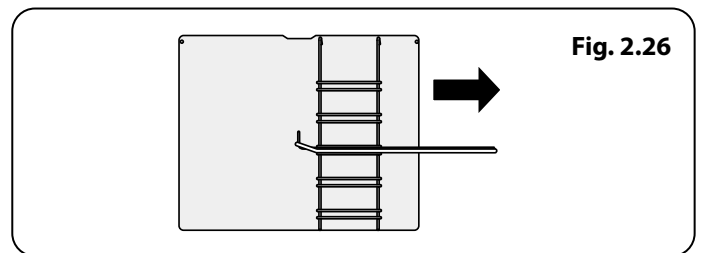
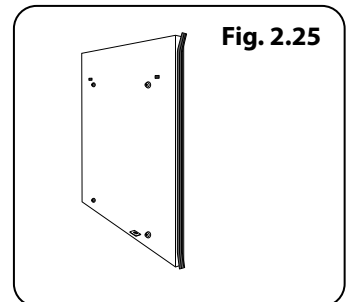
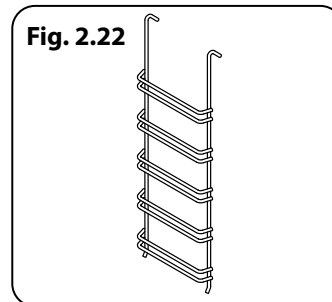
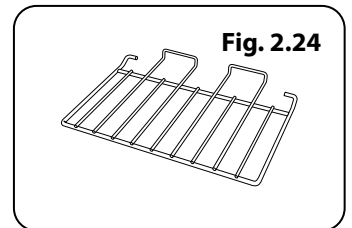
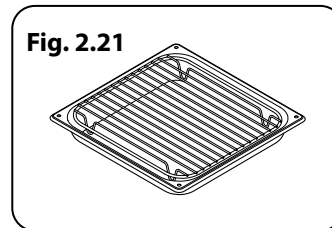
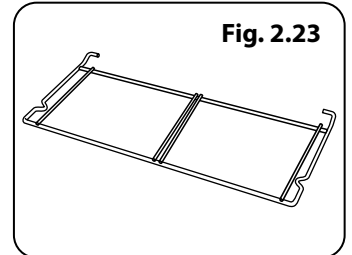
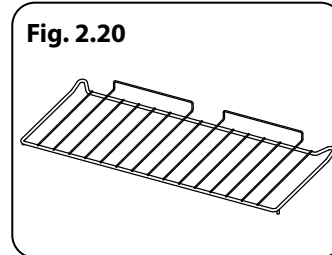
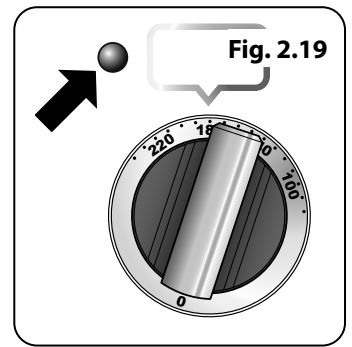
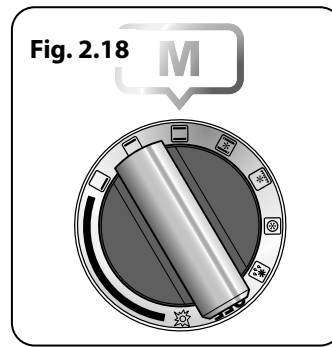

3. 6 Button clock

Fig. 3.1

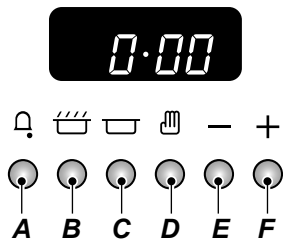

A – Minute minder, B – 'Cook' time, C – 'Stop' time, D – Manual, E & F – Time setting buttons

Symbol	Function	Notes
[🔔]	Minute Minder is active	
[🍳]	Oven(s) can be operated	If the 'cook' [🍳] symbol is not displayed the program has either: ended and the oven(s) are non-operational the oven(s) are being controlled by an automatic program that has not started
[AUTO]	Oven(s) are being controlled in semi-automatic or automatic mode	
[P]	Self clean (pyrolytic) mode has been enabled	Your cooker may not have this pyrolytic function
[dot]	Flashes during setting the time of day	

Table 3.1 overview of the functions

Setting the time

The clock must be set to the time of day before the oven will work. The time of day can be set in two ways:

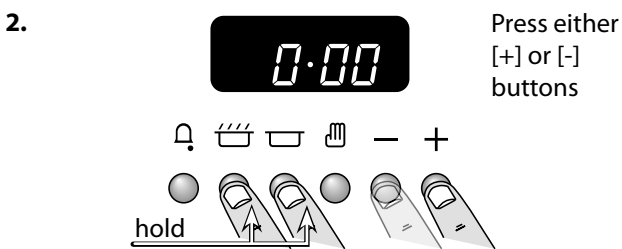
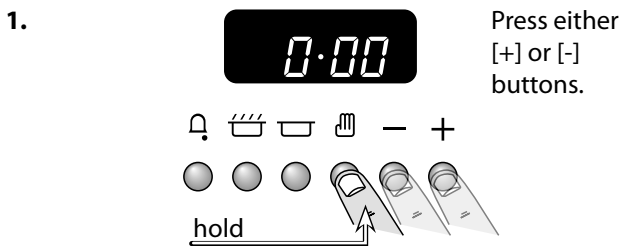

DO NOT forget that it is a 24-hour clock.

If you need to reset the clock/cooker, turn off the power and wait several minutes, then start again.

Automatic dimming

Providing there are no automatic programs set, and the minute minder is not active, your clock will automatically dim during the hours between 22:00 and 06:00.

Minute Minder

Step. 1 Press and hold the [🔔] button

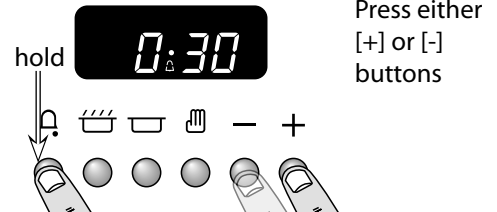

Step. 2 Press [🔔] button to check how long left

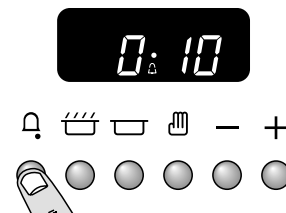

Step. 3 To stop the alarm press any button.

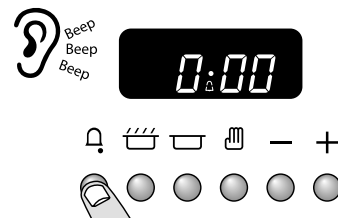

Reset minute minder and automatic programs

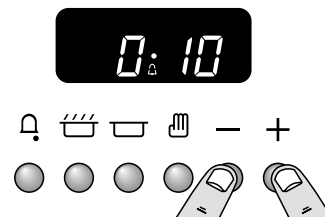

Beeper tone adjustment.

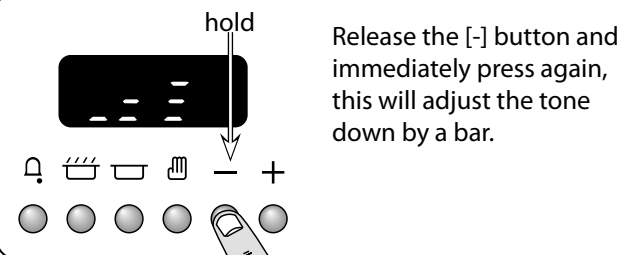

Setting a cook duration (main oven only)

You have set the required temperature and function mode and you would like the oven to automatically stop.

Step. 1

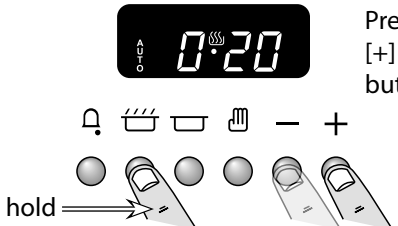

Press either [+] or [-] buttons.

Step. 2 To stop the alarm press any button.



REMEMBER Turn the oven control knob to 0.

Setting a cook end time (main oven only)

You have set the required temperature and function mode and you would like the oven to automatically stop.

Step. 1



Step. 2

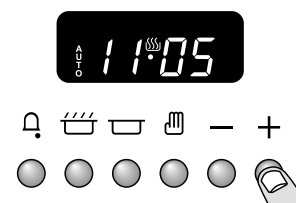

Step. 3 To stop the alarm press any button.



REMEMBER Turn the oven control knob(s) to 0.

To start and stop the ovens automatically (main oven only)

You have set the required temperature and function mode and you would like the oven to automatically stop.

Step. 1

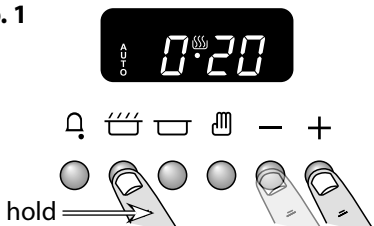

Press either [+] or [-] buttons to set cooking duration.

Step. 2

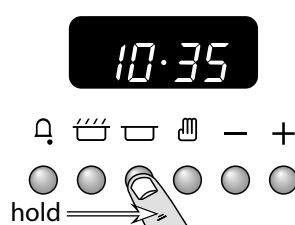

Display will show the current time.

Step. 3

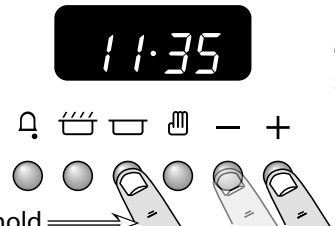

Press either [+] or [-] buttons to set stop time. Release buttons.

Step. 4

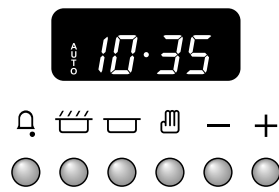

The current time and the AUTO symbol will show on the display.

Step. 5 To stop the alarm press any button.



REMEMBER Turn the oven control knob(s) to 0.

4. Cooking tips

Cooking with a multi-function oven

Remember: Not all modes are suitable for all food types. The oven cooking times given are intended for a guide only.

Tips on cooking with the timer

If you want to cook more than one dish, choose dishes that require approximately the same cooking time. However, dishes can be 'slowed down' slightly by using small containers and covering them with aluminium foil, or 'speeded up' slightly by cooking smaller quantities or placing them in larger containers.

Very perishable foods such as pork or fish should be avoided if a long delay period is planned, especially in hot weather.

 **DO NOT place warm food in the oven to be timed.**

 **DO NOT use a timed oven that is already warm.**

Whole poultry must be thoroughly defrosted before being placed in the oven. Check that meat and poultry are fully cooked before serving.

General oven tips

The wire shelves should always be pushed firmly to the back of the oven.

Baking trays with food cooking on them should be placed level with the front edge of the oven's wire shelves. Other containers should be placed centrally. Keep all trays and containers away from the back of the oven, as overbrowning of the food may occur.

When the oven is on, do not leave the door open for longer than necessary, otherwise the knobs may get very hot.

- Always leave a "finger's width" between dishes on the same shelf. This allows the heat to circulate freely around them.
- To reduce fat splashing when you add vegetables to hot fat around a roast, dry them thoroughly or brush lightly with cooking oil.
- Where dishes may boil and spill over during cooking, place them on a baking tray.
- Sufficient heat rises out of the oven while cooking to warm plates in the grill compartment.
- If you want to brown the base of a pastry dish, preheat the baking tray for 15 minutes before placing the dish in the centre of the tray.

5. Cooking Table

The oven control settings and cooking times given in the table below are intended to be used **as a guide only**. Individual tastes may require the temperature to be altered to provide a preferred result.

Food is cooked at lower temperature in a fan oven than in a conventional oven. When using recipes, reduce the fan oven temperature by 10°C and the cooking time by 5-10 minutes. The temperature in the fan oven does not vary with height in the oven so you can use any shelf.

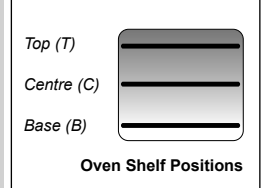

Food	Conventional Oven °C (Shelf Position)	Fan Oven Temperature	Approximate Cooking Time		
Meat					
Beef (no bone)	160 (C)	150 °C	30-35 minutes per 500g +30-35 minutes.	Thoroughly thaw frozen joints before cooking. Meat may be roasted at 220°C (210°C for fan oven) and the cooking time adjusted accordingly. For stuffed and rolled meats, add approximately 10 minutes per 500g, or cook at 200°C (190°C) for 20 minutes then 160°C (150°C) for the remainder.	
	200 (C)	190 °C	20-25 minutes per 500g +20-25 minutes.		
Lamb	160 (C)	150 °C	30-35 minutes per 500g +30-35 minutes.		
	200 (C)	190 °C	25-30 minutes per 500g +25-30 minutes.		
Pork	160 (C)	150 °C	35-40 minutes per 500g +35-40 minutes.		
	200 (C)	190 °C	25-30 minutes per 500g +25-30 minutes.		
Poultry					
Chicken	160 (C)	150 °C	20-25 minutes per 500g +20-25 minutes.		For stuffed poultry, you could cook at 200°C (190°C) for 20 minutes then 160°C (150°C) for remainder. Do not forget to include the weight of the stuffing. For fresh or frozen pre-packed poultry, follow instructions on the pack. Thoroughly thaw frozen poultry before cooking.
	200 (C)	190 °C	15-20 minutes per 500g +15-20 minutes.		
Turkey	160 (C)	150 °C	20 minutes per 500g +20 minutes.		
	200 (C)	190 °C	15 minutes per 500g +15 minutes.		
Duck	160 (C)	150 °C	25-30 minutes per 500g.		
	200 (C)	190 °C	20 minutes per 500g.		
Casserole	140-150 (C)	130 °C-140 °C	2-4 hours according to recipe.		
Yorkshire Pudding	220 (C)	210 °C	Large tins 30-35 minutes; individual 10-20 minutes.		
Cake					
Very rich fruit - Christmas, wedding, etc.	140 (C/B)	130 °C	45-50 minutes per 500g of mixture.	Using the conventional oven: When two tier cooking leave at least one runner space between shelves. Position the baking tray with the front edge along the front of the oven shelf. Up to three tiers can be cooked on, in a fan oven, at the same time. But make sure to leave at least one runner space between each shelf being cooked on.	
Fruit 180 mm tin	150 (C/B)	140 °C	2-2½ hours.		
Fruit 230 mm tin	150 (C/B)	140 °C	Up to 3½ hours.		
Madeira 180 mm	160 (C/B)	150 °C	80-90 minutes.		
Queen cakes	190 (C/B)	180 °C	15-25 minutes.		
Scones	220 (C/B)	210 °C	10-15 minutes.		
Victoria sandwich					
180 mm tin	180 (C/B)	170 °C	20-30 minutes.		
210 mm tin	180 (C/B)	170 °C	30-40 minutes.		
Desserts					
Shortcrust tarts	200 (C/B)	190 °C	20-30 minutes on a preheated tray.	Up to three tiers can be cooked on, in a fan oven, at the same time. But make sure to leave at least one runner space between each shelf being cooked on.	
Fruit pies	200 (C/B)	190 °C	35-45 minutes.		
Tartlets	200 (C/B)	190 °C	10-20 minutes according to size.		
Puff pastry	210 (C/B)	200 °C	20-40 minutes according to size.		
Meringues	100 (C/B)	90 °C	2-3 hours.		
Baked egg custard	160 (C/B)	150 °C	45-60 minutes.		
Baked sponge pudding	180 (C/B)	170 °C	40-45 minutes.		
Milk pudding	140-150 (C/B)	130 °C-140 °C	2 to 3 hours.		
Bread	210 (C)	200 °C	20-30 minutes.		
Fish					
	Fanned Grilling				
Fillet	190 (C/B)	190 °C (C/B)	15-20 minutes		
Whole	190 (C/B)	190 °C (C/B)	15-20 minutes per 500g.		
Steak	190 (C/B)	190 °C (C/B)	Steaks according to thickness.		

6. Cleaning your cooker

Isolate the electricity supply before carrying out any major cleaning. Allow the cooker to cool.

⚠ NEVER use paint solvents, washing soda, caustic cleaners, biological powders, bleach, chlorine based bleach cleaners, coarse abrasives or salt.

⚠ DO NOT mix different cleaning products – they may react together with hazardous results.

All parts of the cooker can be cleaned with hot soapy water – **but take care that no surplus water seeps into the appliance.**

Remember to switch the electricity supply back on and reset the clock before reusing the cooker.

Daily care

Cleaning the cooker is not a welcomed chore, but it has to be done to maintain efficiency and appearance. Remember it is better to wipe up any spills as they occur, this will prevent them burning on and becoming more difficult to remove later.

⚠ Make sure the flow of combustion and ventilation air to the cooker is unobstructed – for example by build-up of fats or grease.

On Natural gas the hotplate burner flames should be a bluish colour with, at most, a slight yellowish fringe.

On LP gas the flames may be “softer”. The hotplate burner flames may have a slight yellowish tip.

If the flame burns with a long white tip you should call for service.

Cleaning for spills

For spills and boil-overs that occur while cooking, turn off the burner as soon as possible and allow it to cool. Do not clean until the area is completely cooled down. Wipe up spills as soon as possible.

DO NOT allow surplus water to seep into the cooker.

Hotplate burners

The burner heads and caps can be removed for cleaning.

⚠ DO NOT put the burner heads in a dishwasher.

Make sure they are absolutely dry before replacing.

Single ring burners

When refitting the burner head, make sure that the notch lines up with the electrode or hole in the base. Check that the burner head is level and that the cap is fitted centrally on the burner head (**Fig. 6.1**).

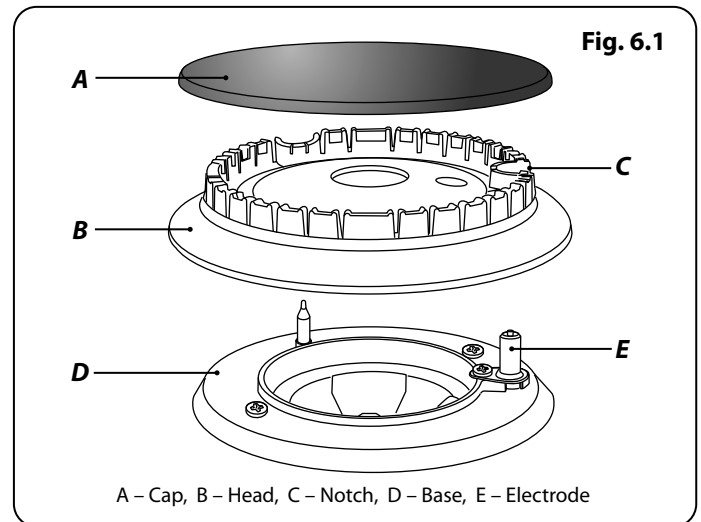
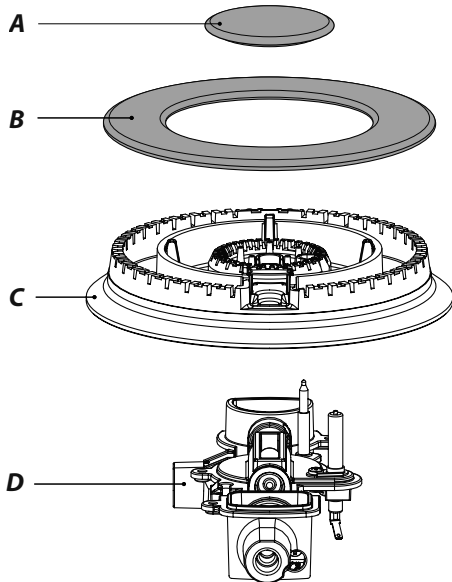

Fig. 6.2 A



A – inner burner cap, B – outer burner cap, C – burner head, D – wok burner base

Wok Burner

When reassembling the wok burner (**Fig. 6.2**) turn over the large base ring and find the 'D' shaped area (**Fig. 6.3**). Turn the head until the 'D' matches the one on the burner base. Flip the burner over once again and place it on the burner base.

Check the burner slots are not blocked. If a blockage occurs, remove stubborn particles using a toothbrush (**Fig. 6.4**).

Now fit the two burner caps, making sure that they are seated properly.

Check the burner ports are not blocked. If a blockage occurs, remove stubborn particles using a piece of fuse wire.

Griddle

Always clean the griddle after use. Allow it to cool completely before removing. Immerse the griddle plate in hot soapy water. Use a soft cloth or, for stubborn stains, a nylon washing up brush.

Wok Cradle

Recommended cleaning materials are hot soapy water, a moistened soap pad, cream cleaner or nylon scourer.

Fig. 6.3

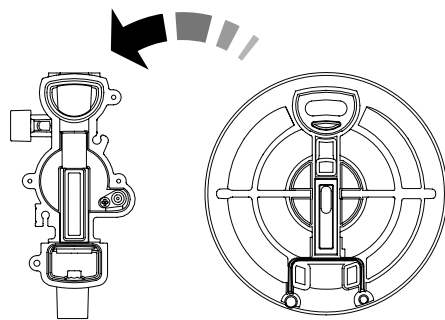

Control panel and oven doors

The control panel and control knobs should only be cleaned with a soft cloth wrung out in clean hot soapy water – but take care that no surplus water seeps into the appliance. Wipe with a clean dampened cloth then polish with a dry cloth. The oven doors should only be cleaned with a soft cloth wrung out in clean hot soapy water.

Fig. 6.4

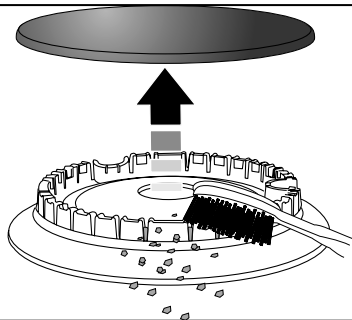

Removing the oven door outer panel

The outer door panel can be removed so that the inside of the glass can be cleaned. Undo the 4 screws (2 each side) in the door (**Fig. 6.5**).

Open the door slightly and, using the handle, carefully lift the door outer upwards.

Refit in reverse.

Fig. 6.5



Self-clean oven

- ⚠ WARNING:** Remove all cookware, shelves, and the shelf supports from the oven before using the self-clean function. If the shelves and supports are left in the oven they will discolour and become rough.
- ⚠ WARNING:** Using the self-cleaning function results in higher temperatures than those for normal cooking. Under such conditions the surfaces may get hotter than usual so children should be kept away.
- ⚠ WARNING:** Remove the divider before using the self-clean function. See "Energy saving panel" page 12'.
- ⚠ DO NOT clean the door gasket:** the door gasket is essential for a good seal. Care should be taken not to rub, damage or move the gasket.
- ⚠ DO NOT use oven cleaners:** no commercial oven cleaner or oven liner protective coating of any kind should be used in or around any part of the oven.
- ⚠ Clean only parts listed in this User Guide.**
- ⚠ DO NOT use the oven light while in self-cleaning mode.**

Before using the self-clean function

Pre-clean any areas that are not reached by the self-clean cycle, such as the outer edges of the oven door. Wipe up any excess fat or liquids.

Before operating the self-clean cycle, use hot water and detergent or a paste of water and baking soda to remove any difficult spots. Rinse off all residue with vinegar water. This will prevent this soil from being baked on by the high heat of the self-cleaning cycle.

Self-clean operation

NOTE: The minute minder can still be used when the clock is controlling the pyrolytic cycle.

Set the oven function control to self-clean (**Fig. 6.6**). The timer display will now show a 'P' (**Fig. 6.7**).

Press the [👉] button once (**Fig. 6.8**) to set the default cleaning time (3 hours). The cleaning cycle will start immediately.

To adjust the cleaning cycle duration, press and hold the [👉] button. The 'P' will no longer be displayed and [AUTO] will flash. Press either the [-] or [+] buttons and set the required duration; see **Table 6.1**. Release the [👉] button once the duration is set.

Note that the maximum time for the self-cleaning operation is 4 hours. The minimum time is 1 hour.

The cooling fan will switch to high speed and as soon as a certain temperature is reached the oven door will lock as indicated by the illuminated interlock neon (**Fig. 6.9**).

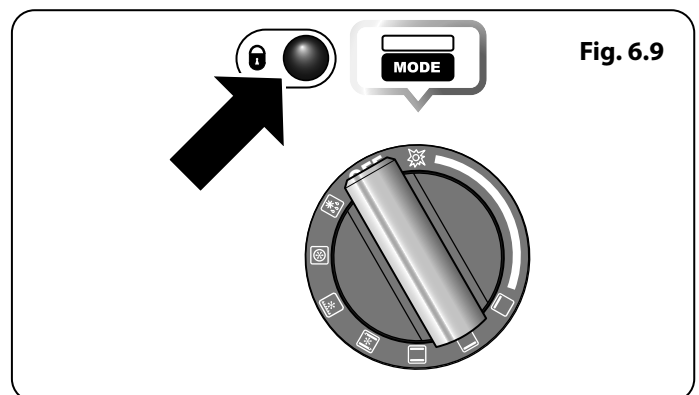
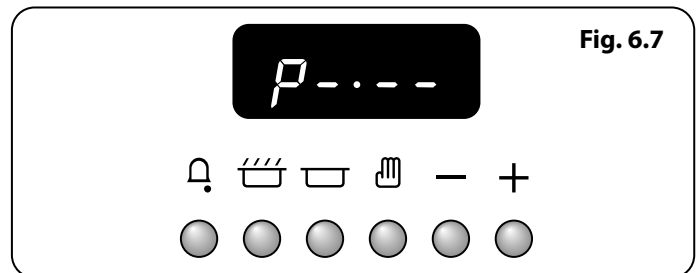
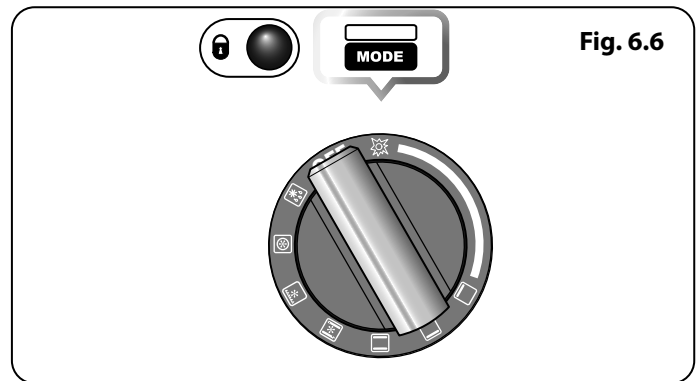

Hours	Soiling
2 hours	Normal clean
3 hours	Heavy soiling
4 hours	Very heavy soiling

Table 6.1

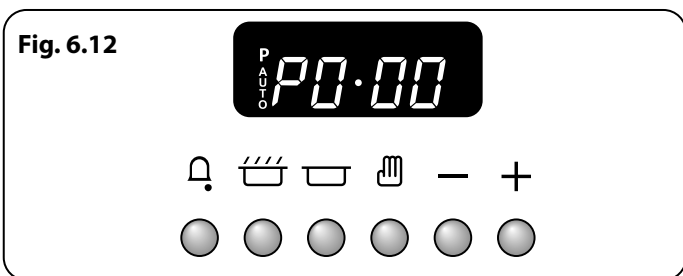
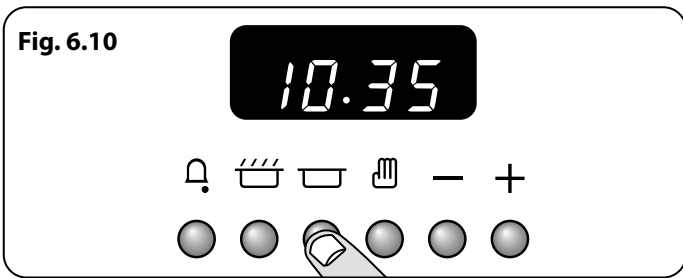

Symbol	Function	Notes
[A]	Sets the Minute Minder	Used with the [+] and [-] buttons
[P]	Sets the Pyrolytic duration	Used with the [+] and [-] buttons
[E]	Sets the Pyrolytic end time	Used with the [+] and [-] buttons
[-]	Decreases time interval	Holding this button down allows a quick set
[+]	Increases time interval	Holding this button down allows a quick set
[+] & [-]	Clears the Pyrolytic duration to zero	

Table 6.2

NOTE: Because of the high temperatures generated during the self-cleaning, the door will remain locked for a period after the cleaning cycle has finished. When the oven temperature has fallen sufficiently the interlock neon will go out and the door will unlock.

When the door has unlocked turn the oven function control back to OFF.

⚠ WARNING: The oven will still be hot!

When the door has unlocked and the oven has cooled, use a damp cloth to clean the debris and ash.

To start the self-cleaning cycle automatically

By using the clock, the self-clean cycle can be programmed to turn on and off automatically.

NOTE: You cannot set the start time directly – this is set automatically by setting the ‘Cleaning period’ and the ‘stop time’. This is the same method as used for normal automatic cooking.

Set the oven function control to self-clean (Fig. 6.6). Press the [P] button once to set the default cleaning time (Fig. 6.8).

To adjust the cleaning cycle duration, press the [E] button and press either the [-] or [+] button and set the time as required.

Now press the [E] button once to bring up the minimum ‘Stop time’ (Fig. 6.10) on the display. Press the [+] button until the required ‘Stop time’ shows (Fig. 6.11). Release the buttons. The symbols [AUTO] and [P] are displayed. When the self-clean start time is reached the [P] symbol will be displayed and the self-clean cycle will start automatically.

At the end of the self clean [AUTO] will flash and the clock will return to (0.00) (Fig. 6.12). Turn the self-clean function switch off to return to manual cooking.

To cancel the self-cleaning cycle

To cancel the self-clean function, hold down the [+] & [-] buttons. The cycle time is re-set back to (0.00), the heating part of the cycle will end and the cooling part of the cycle will start. When the oven temperature has fallen sufficiently the interlock neon will go out and the door will unlock.

When the door has unlocked turn the oven function control back to OFF.

⚠ WARNING: DO NOT attempt to stop the self-clean cycle by turning the oven function control to OFF. While this will stop the heating part of the cleaning cycle it will also stop the ventilation fans from running and cause the oven thermal cut-out to trip.

For an overview of the functions refer to Table 6.2.

Cleaning table

Cleaners listed are available from supermarkets or electrical retailers as stated (**Table 6.3**).

For enamelled surfaces use a cleaner that is approved for use on vitreous enamel.

Regular cleaning is recommended. For easier cleaning, wipe up any spillages immediately.

Hotplate		
Part	Finish	Recommended Cleaning Method
Hob top (including burner heads and caps)	Enamel, stainless steel, aluminium	Hot soapy water, soft cloth. Any stubborn stains remove gently with a nylon scourer.
Ceramic/induction hob	Toughened glass	Hot soapy water; cream cleaner/scourer if necessary.
Griddle plate (some models only)	Non-stick surface	Allow to cool. Wash in hot soapy water. Do not use abrasive cleaners/scourers. Dishwasher.
Warming zone (some models only)	Toughened glass	Hot soapy water, cream cleaner/scourer if necessary.
Outside of Cooker		
Part	Finish	Recommended Cleaning Method
Door, door surround and Storage drawer exterior	Enamel or paint	Hot soapy water, soft cloth. Any stubborn stains, remove gently with a liquid detergent.
	Stainless steel	E-cloth (electrical retailers) or microfibre all-purpose cloth (supermarket).
Sides and plinth	Painted surface	Hot soapy water, soft cloth.
Splashback/rear grille	Enamel or stainless steel	Hot soapy water, soft cloth. Cream cleaner, with care, if necessary.
Control panel	Paint, enamel or stainless steel	Warm soapy water. Do not use abrasive cleaners on lettering.
Control knobs/handles & trims	Plastic/chrome, copper or lacquered brass	Warm soapy water, soft cloth.
	Brass	Brass polish.
Oven door glass/glass lid	Toughened glass	Hot soapy water, cream cleaner/scourer if necessary.
Oven and Grill		
Part	Finish	Recommended Cleaning Method
Sides, floor & roof of oven NOT 'COOK & CLEAN' OVEN PANELS (see below)	Enamel	Any proprietary oven cleaner that is suitable for enamel. CAUTION: CORROSIVE/CAUSTIC OVEN CLEANERS: FOLLOW MANUFACTURER'S INSTRUCTIONS. Do not allow contact with the oven elements.
'Cook & Clean' oven panels (some models only)	Special enamel that partly cleans itself	This surface cleans itself at 200°C and above, or the panels can be removed and washed with hot soapy water and a nylon brush.
Oven shelves, Handyrack, grill trivet, Handygrill rack (some models only)	Chrome	An oven interior cleaner that is suitable for chrome. Soap filled pad. Dishwasher.
Grill pan/meat tin (some models only)	Enamel	Hot soapy water. Soap filled pad. Dishwasher.

Table 6.3

7. Troubleshooting

Hotplate ignition or hotplate burners faulty

Is the power on? Is the clock illuminated?

If not, there maybe something wrong with the power supply.

Are the sparker (ignition electrode) or burner slots blocked by debris?

Are the burner trim and caps correctly located? See the section on 'Cleaning'?

Hotplate burners will not light

Make sure that the burner parts have been replaced correctly after wiping or removing for cleaning.

Check that there is not a problem with your gas supply. You can do this by making sure that other gas appliances you may have are working.

Do the burners spark when you push the control?

If not, verify that the power is on by checking that the clock is illuminated.

Steam is coming from the oven

When cooking foods with high water content (e.g. oven chips) there may be some steam visible at the rear grille.

Take care when opening the oven door, as there may be a momentary puff of steam when the oven door is opened. Stand well back and allow any steam to disperse.

What cleaning materials are recommended for the cooker?

See the 'Cleaning' section for recommended cleaning materials.

⚠ Never use caustic or abrasive cleaners as these will damage the surface.

An oven fan is noisy

The note of the oven fan may change as the oven heats up – this is perfectly normal.

The knobs get hot when I use the oven. Can I avoid this?

Yes, this is caused by heat rising from the oven and heating them up. Do not leave the oven door open.

The fascia gets hot when I use the oven

The cooker is cooled by a fan. If the fascia becomes excessively hot when the cooker is in use then the cooling fan may have failed. Should this occur please contact your installer, a qualified repair engineer or Customer Service to arrange for its repair.

If there is an installation problem and I don't get my original installer to come back to fix it who pays?

You do. Service organisations will charge for their call outs if they are correcting work carried out by your original installer. It is in your interest to track down your original installer.

Power failure

In the event of a failure in the electrical supply, remember to reset the clock to make sure that the timed oven continues to operate.

Poor performance

In the unlikely event that, after installation, the appliance does not perform correctly please contact your distributor (see "Service and Spares" on page 25).

Food is cooking too slowly, too quickly, or burning

Cooking times may differ from your previous oven.

Check that you are using the recommended temperatures, shelf positions and tray sizes – see the oven cooking guide. The oven control settings and cooking times are intended to be used only as a guide.

Individual tastes may require the temperature to be altered either way, to get the results you want.

The oven is not cooking evenly

Do not use a baking tray with dimensions larger than those specified in the section on 'General Oven Tips'.

If you are cooking a large item, be prepared to turn it round during cooking.

If two shelves are used, check that space has been left for the heat to circulate. When a baking tray is put into the oven, make sure that it is placed centrally on the shelf.

Check that the door seal is not damaged and that the door catch is adjusted so that the door is held firmly against the seal.

A dish of water when placed on the shelf should be the same depth all over. (For example, if it is deeper at the back, then the back of the cooker should be raised up or the front lowered.) If the cooker is not level arrange for your supplier to level it for you.

Oven not coming on

Is the power on? Is the clock illuminated? If not, there may be something wrong with the power supply.

Is the cooker supply on at the isolator switch?

Has the time of day been set?

The timed oven is not coming on when automatic cooking

Has the oven knob been left in the OFF position by mistake?

Is the oven locked (see above)?

Fig. 7.1

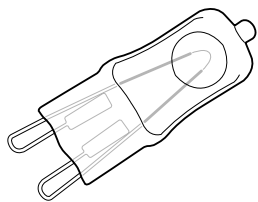

Oven temperature getting hotter as the cooker gets older

If turning the temperature down using the oven control knob has not worked, or has only worked for a short time, then you may need a new thermostat. This should be fitted by a service person.

Oven lights are not working

The bulb has probably burnt out. You can buy a replacement bulb (which is not covered under the warranty) from a good electrical shop.

Ask for a 40W - 230V halogen lamp (G9) (**Fig. 7.1**).

Turn off the power at the circuit breaker.

Before removing the existing bulb, turn off the power supply and make sure that the oven is cool. Open the oven door and remove the oven shelves.

Remove the bulb cover by turning it a quarter turn, counter-clockwise. It may be very stiff (**Fig. 7.2**).

Pull the existing bulb to remove it. When handling the replacement bulb, avoid touching the glass with your fingers, as oils from your hands can cause premature failure. Push, click in the replacement bulb.

Screw back the bulb cover. Turn on the circuit breaker and check that the bulb now lights.

Fig. 7.2

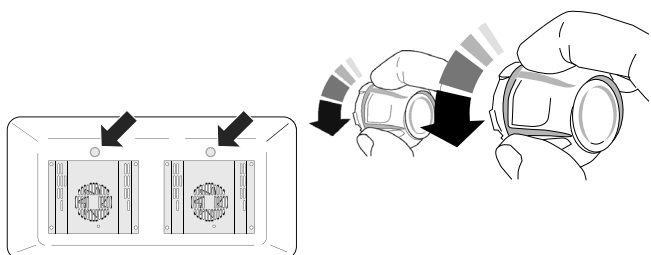

INSTALLATION

Check the appliance is electrically safe when you have finished.

8. Service and Spares

Firstly, please complete the appliance details below and keep them safe for future reference – this information will enable us to accurately identify the particular appliance and help us to help you. Filling this in now will save time and inconvenience if you later have a problem with the appliance. It may also be of benefit to keep your purchase receipt with this leaflet. You may be required to produce the receipt to validate a warranty field visit.

Distributor's Name and Address	Andi-Co Australia Pty Ltd. 1 Stamford Road, Oakleigh, VIC 3166 Customer Care Tel: 1300 650 020 Email: service@andico.com.au
Name of Appliance	
Appliance Serial Number*	
Fuel Type	
Date of Purchase	
Installer's Name, Address and Telephone No.	
Date of Installation	

* This information is on the appliance data badge.

If You Have a Problem

In the unlikely event that you have a problem with your appliance, please refer to rest of this booklet, especially the problem solving section, first to check that you are using the appliance correctly.

If you are still having difficulty, contact Customer Care on 1300 650 020 or email service@andico.com.au.

Please Note

For warranty information and how to request a remedy, please refer to the Warranty Statement at <https://www.andico.com.au/warranty/> or contact Customer Care.

Out of Warranty

We recommend that our appliances are serviced regularly throughout their life to maintain the best performance and efficiency. The frequency of service will depend on usage – for normal usage once a year should suffice.

Service work should only be carried out by a suitably Authorised Person.

Spare Parts

To maintain optimum and safe performance, we recommend that only genuine spare parts are used. Do not use re-conditioned or unauthorised controls. Contact Spare Parts on (03) 9569 7744 or email spares@andico.com.au

9. Installation

Safety Requirements and Regulations

⚠ Please read the Before you start... chapter, before you begin any installation and maintenance work on this appliance.

You must be aware of the following safety requirements & regulations.

⚠ Prior to installation, make sure that the local distribution conditions (nature of the gas and gas pressure) and the adjustment of the appliance are compatible.

⚠ The appliance must be installed in accordance with the regulations in force and only in a well ventilated space.

⚠ Read the instructions before installing or using this appliance.

The regulations and standards are as follows:

- AS/NZS 5601 – ‘Gas Installations’
- AS/NZS 3000 - ‘Wiring Rules’

In your own interest and that of safety, it is law that all gas appliances be installed by competent persons.

⚠ Failure to install the appliance correctly could invalidate any warranty or liability claims and lead to prosecution.

The cooker must be installed in accordance with all local gas fitting regulations, municipal building codes, electrical wiring regulations and any other relevant statutory regulations.

⚠ WARNING!
This appliance should not be used in marine craft, caravans or mobile homes.

Provision of Ventilation

This appliance is not connected to a combustion products evacuation device. Particular attention shall be given to the relevant requirements regarding ventilation.

The room containing the cooker should have an adequate air supply.

Install the cooker in a location to allow the complete combustion of gas, proper flueing and to maintain ambient temperature of the immediate surroundings at safe limits, under normal condition.

Location of Cooker

The cooker may be installed in a kitchen/kitchen diner but **NOT** in a room containing a bath or shower.

NOTE: An appliance for use on Propane must not be installed in a room or internal space below ground level, e.g. in a basement.

Conversion

All models are supplied set for use on Natural gas. A conversion kit for Propane gas is included with the appliance. See the instructions that are supplied with the conversion kit.

After converting the appliance, please attach the Gas Conversion sticker over the appropriate area of the data badge – this will identify the gas type for which the appliance is now set.

INSTALLATION

Check the appliance is electrically safe and gas sound when you have finished.



You will need the following equipment to complete the cooker installation satisfactorily:

- Flexible gas hose.
- Gas pressure tester/manometer.
- Multimeter: For electrical checks.

You will also need the following tools:

1. Electric drill
2. Masonry drill bit (only required if fitting the cooker on a stone or concrete floor)
3. Wall plugs (only required if fitting the cooker on a stone or concrete floor)
4. Steel tape measure
5. Cross head screwdriver
6. Flat head screwdriver
7. 4 mm & 3 mm Allen keys
8. Spirit level
9. Pencil
10. Adjustable spanner
11. 13 mm spanner or socket wrench
12. Screws for fitting the restraining chain and stability bracket

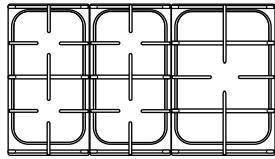
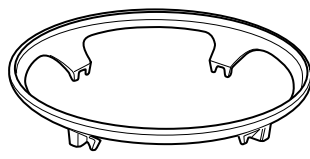
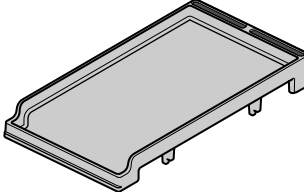
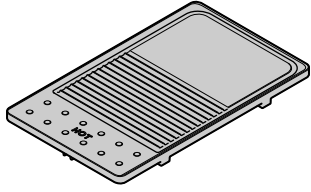
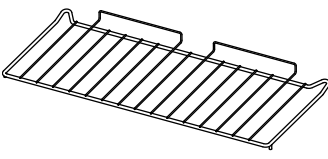
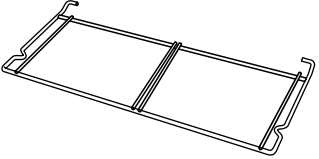
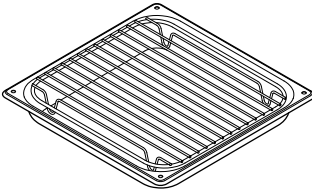
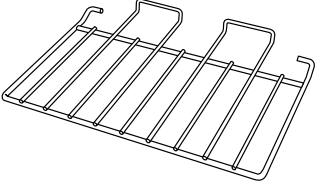
Checking the Parts:

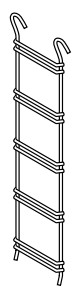
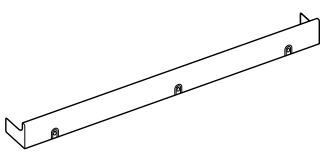
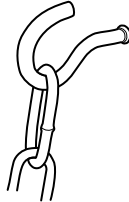
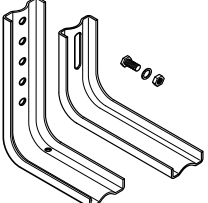
Pan supports	Wok cradle
	
Teppanyaki (supplied)	Griddle (optional)
	
Full capacity shelf	Grill pan tray support
	
2 grill pans & trivets	3 energy saving shelves
	
Divider	4 ladder side supports
	
Plinth	Restraining chain & hook
	
Stability bracket	
	

INSTALLATION

Check the appliance is electrically safe and gas sound when you have finished.

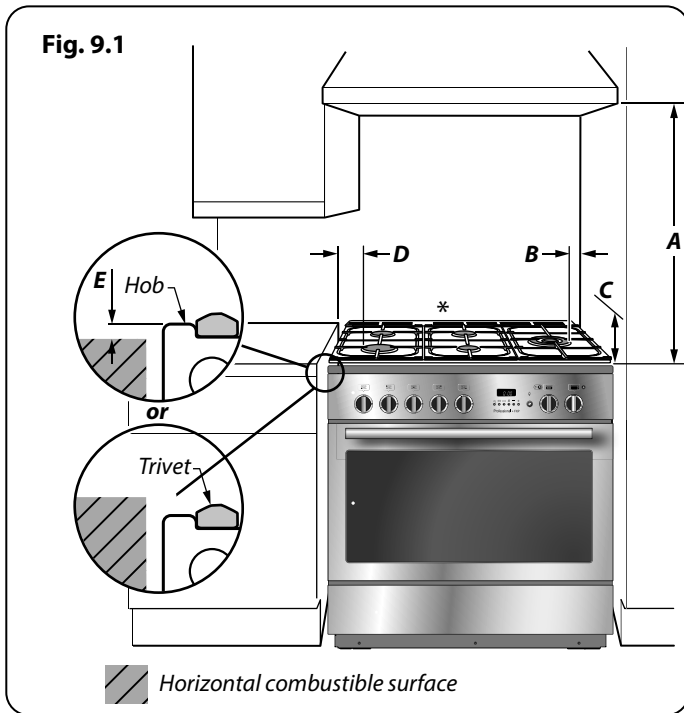

Positioning the Cooker

The diagram (**Fig. 9.1**) shows the minimum recommended distance from the cooker to nearby surfaces as given in AS/NZS 5601.

Where the appliance is installed next to cabinetry, the cabinet material must be capable of withstanding 70°C. If this appliance is installed near vinyl wrapped surfaces, use an installation kit available from the vinyl-wrap supplier. Falcon cannot accept any responsibility for damage caused due to installation into cabinets with low temperature tolerances.

*Any splashback must be fitted in accordance with the manufacturers instructions. Allowance should be made for the additional height of the flue trim, which is fitted to the cooker hob.

1. Overhead - Measurement A

The minimum height of any surface above the cooker is 650 mm above the hotplate.

Cookerhoods and exhaust fans shall be installed in accordance with the manufacturer's instructions. However, in no case shall the clearance between the highest part of the hob of the cooking appliance and a cookerhood be less than 650 mm or, for an overhead exhaust fan, 750 mm.

2. Side Clearances - Measurements B & C

Where **B**, measured from the periphery of the nearest burner to any vertical combustible surface, or vertical combustible surface covered with toughened glass or sheet metal, is less than 200 mm, the surface shall be protected to make sure that the combustible surface does not exceed 65 °C above ambient*. Even with the surface protected, the dimension **B** should not be less than 135 mm above hotplate level.

*The fixing of 5mm thick ceramic tiles to the surface, or attaching fire resistant material to the surface and covering with sheet metal with a minimum thickness of 0.4 mm to a height C of not less than 150 mm above the hotplate, should satisfy this requirement.

3. Side Clearances - Measurement D & E

Where **D**, the distance from the periphery of the nearest burner to a horizontal combustible surface is less than 200 mm, then **E** shall be 10 mm or more, or the horizontal surface shall be above the trivet. See insets above.

DO NOT place the cooker on a base.

For safety reasons, curtains, must not be fitted immediately behind the cooker.

Surfaces of furniture and walls at the sides and rear of the appliance should be heat, splash and steam resistant. Certain types of vinyl or laminate kitchen furniture are particularly prone to heat damage and discolouration. We cannot accept responsibility for damage caused by normal use of the cooker to any material that de-laminates or discolours at temperatures less than 70 °C above room temperature (as measured by EN30 / EN60335).

INSTALLATION

Check the appliance is electrically safe and gas sound when you have finished.

We recommend a gap of 910 mm between units to allow for moving of the cooker. **DO NOT** box the cooker in – it must still be possible to move the cooker in and out for cleaning and servicing.

Moving the Cooker

⚠ On no account try and move the cooker while it is plugged into the electricity supply.

⚠ The cooker is very heavy, so take great care.

We recommend that two people manoeuvre the cooker. Make sure that the floor covering is firmly fixed, or removed, to prevent it being disturbed when moving the cooker around.

To help you, there are two levelling rollers at the back, and two screw-down levelling feet at the front.

Remove the polystyrene base pack. From the front, tilt the cooker backwards and remove the front half of the polystyrene base (**Fig. 9.2**). Repeat from the back and remove the rear half of the polystyrene base.

Removing the Oven Door

To remove the oven door, open the door fully. Swivel the locking 'U' clips forward to the locking position (**Fig. 9.3**). Grip the sides of the door, lift upwards and then slide the door forwards (**Fig. 9.4**).

Lowering the Two Rear Rollers

To adjust the height of the rear of the cooker, first fit a 13 mm spanner or socket wrench onto the hexagonal adjusting nut (**Fig. 9.5**).

Rotate the nut – clockwise to raise – counter-clockwise to lower. Make 10 complete (360°) turns clockwise.

Make sure you lower BOTH REAR ROLLERS.

Completing the Move

Unfold the rear edge of the pack base tray. Grip the fascia panel and lift the front of the cooker slightly.

Carefully push the cooker backwards off the pack base. Remove the pack base. Position the cooker close to its final position, leaving just enough space to get behind it.

⚠ **DO NOT** use the control knobs to manoeuvre the cooker.

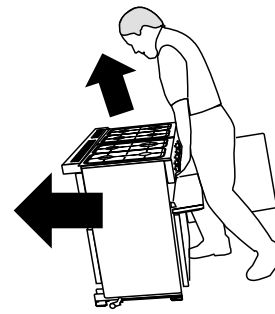

Fig. 9.2

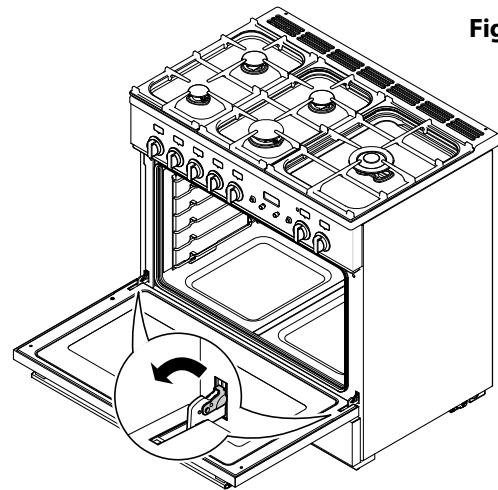

Fig. 9.3

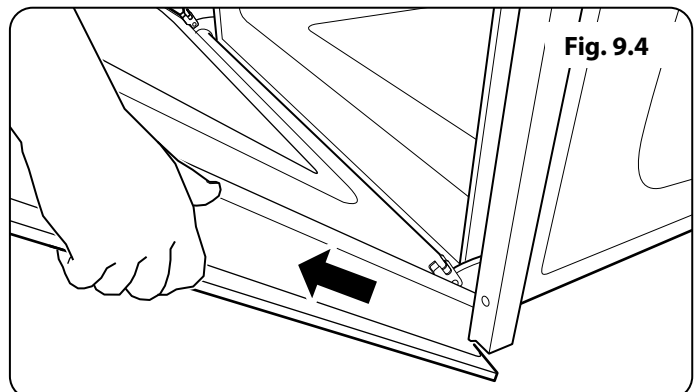

Fig. 9.4

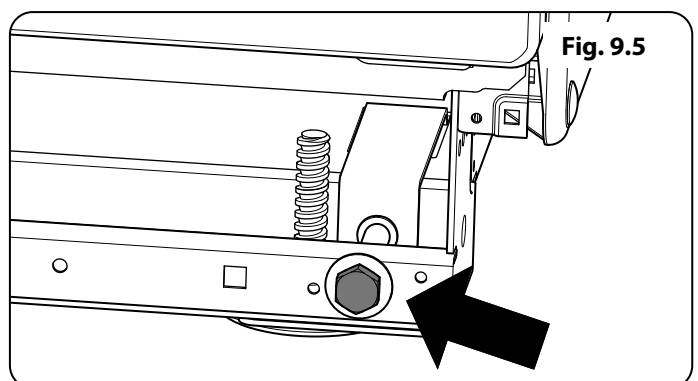

Fig. 9.5

INSTALLATION

Check the appliance is electrically safe and gas sound when you have finished.

Fig. 9.6

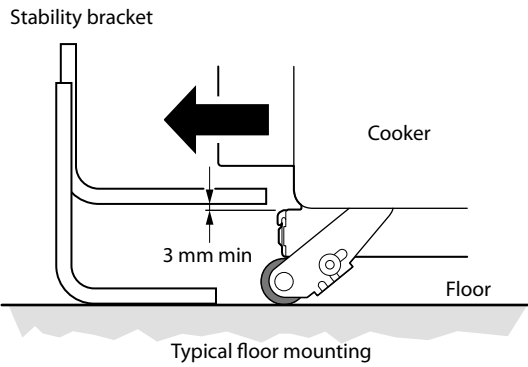

Fig. 9.7

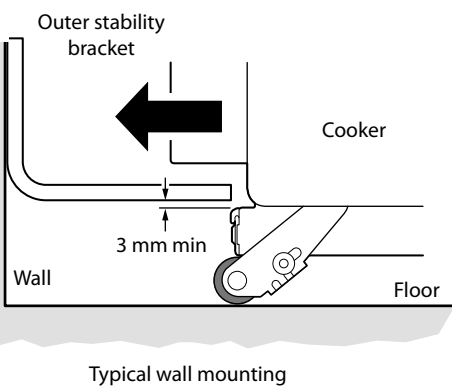
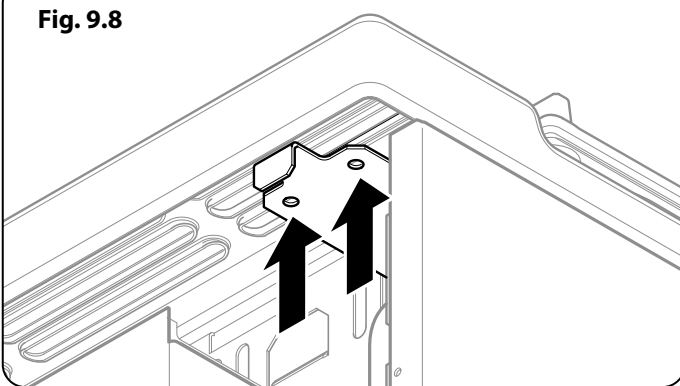

Fig. 9.8



Levelling

You are recommended to use a spirit level on a shelf in one of the ovens to check for level.

Place the cooker in its intended position, taking care not to twist it within the gap between the kitchen units as damage may occur to the cooker or the units.

The front feet and rear rollers can be adjusted to level the cooker. To adjust the height of the rear of the cooker, turn the adjusting nuts at the front bottom corners of the cooker. To set the front feet turn the bases to raise or lower.

Fitting the Stability Bracket and Chain

⚠ A stability bracket and chain MUST be fitted when the cooker is connected to a flexible gas supply.

Unless properly installed, the cooker could be tipped by leaning on the door. Injury might result from spilled hot liquids or from the cooker itself.

⚠ IMPORTANT: The cooker MUST be set to the correct height and levelled before the stability bracket is installed.

Fitting a Stability Bracket

When fitting a stability bracket please refer to the instructions supplied with the bracket for further details on fitting.

When fitting a stability bracket (**Fig. 9.6** and **Fig. 9.7**) adjust the bracket to give the smallest practicable clearance between the bracket and the engagement slot in the rear of the cooker.

Fit the bracket so that it engages as far as possible over the chassis of the cooker.

Fitting the Restraining Chain

The restraining chain MUST be fitted.

The length of chain between the appliance and the wall fixing should prevent strain on the gas and electricity connections, but still allow access to unhook the chain when the cooker is pull forward.

Measure the length of chain required. Use the hexagon-headed screw, washers and bolt supplied in the restraining chain kit to fix the chain to one of the holes at the top of the flue trim bracket (**Fig. 9.8**).

Hook the other end of the chain to the wall fixing.

INSTALLATION

Check the appliance is electrically safe and gas sound when you have finished.

Gas Connection

Must be in accordance with the relevant standards.

The gas supply needs to terminate with a threaded fitting $\frac{1}{2}$ ". The inlet connector is located just below the hotplate level at the rear of the cooker.

Because the height of the cooker can be adjusted and each connection is different it is difficult to give precise dimensions. Ideally, the house supply connection should be in the shaded area (**Fig. 9.9**).

Means of isolation must be provided at the supply point by either an approved quick-connect device or a Type 1 manual shut-off valve.

The hose should be fitted so that both inlet and outlet connections are vertical so that the hose hangs downwards in a 'U' shape (**Fig. 9.9**).

A flexible connection is supplied with the cooker. If it is necessary to use another hose it must be to AS 1869 Class B and be suitable for your gas type.

If in doubt contact your supplier. Screw connect the threaded end of the hose into the gas inlet.

After completing the gas connection, check the cooker is gas sound with a pressure test. When checking for gas leaks do not use washing up liquid – this can corrode. Use a product specifically manufactured for leak detection.

Natural Gas

The adjustable spring loaded gas pressure regulator is preset to give a nominal pressure of 1 kPa on Natural gas. Connect to the Rp $\frac{1}{2}$ inlet on the underside of the pressure regulator.

Propane

This cooker is supplied ready for use on Natural gas. A conversion kit for Propane gas is supplied with the cooker – see the 'Conversion to Propane Gas' section.

Pressure Testing

The pressure test point is accessible on the inlet pipe at the rear. Remove the test nipple screw and fit a pressure gauge to the test point. Turn on and light two of the hotplate burners.

For Natural Gas cookers the pressure should be between 0.95kPa and 1.0kPa.

For Propane X cookers the pressure should be 2.54 kPa.

Electrical Connection

This appliance must be installed by a qualified electrician to comply with with current AS/NZS 3000 Wiring Rules and regulations in force.

Make sure that the mains characteristics (voltage, nominal, power, etc.) match the ratings indicated on the cooker data plate.

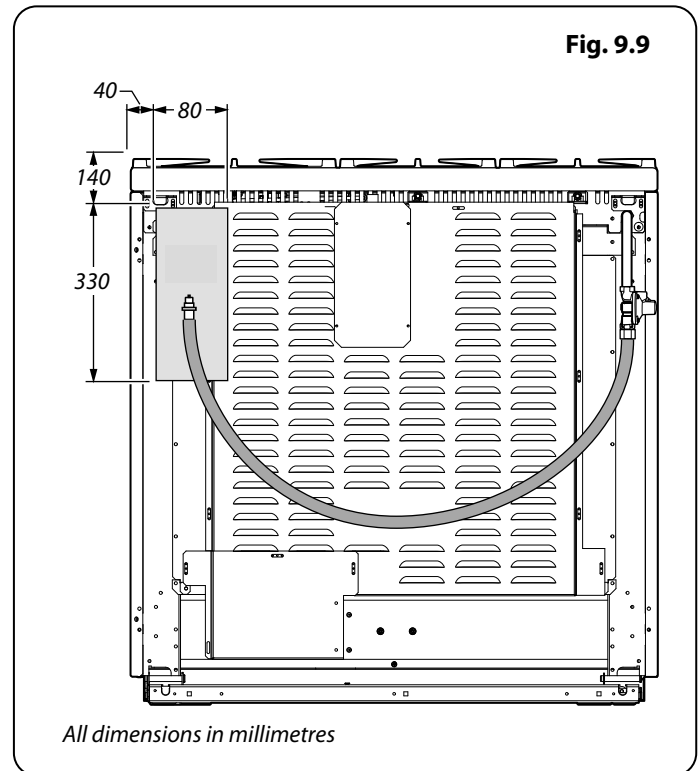

INSTALLATION

Check the appliance is electrically safe and gas sound when you have finished.

Fig. 9.10

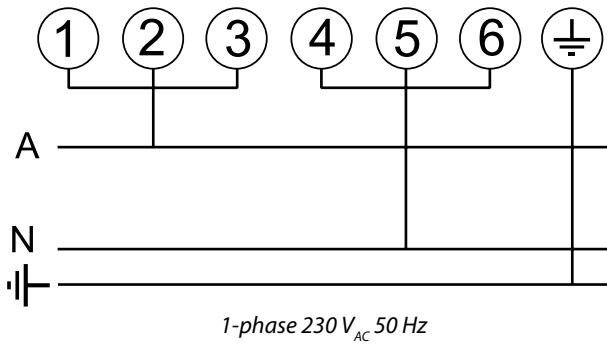

Fig. 9.11

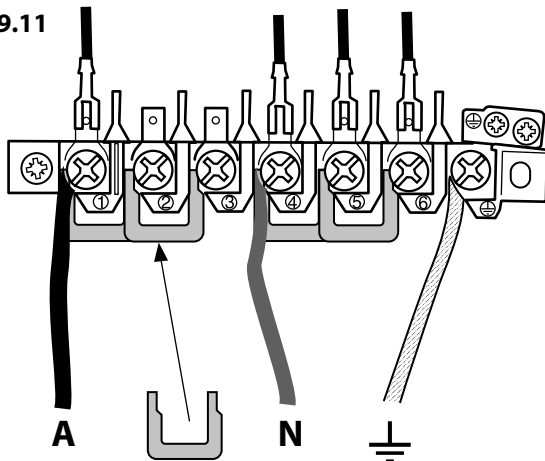

Fig. 9.12

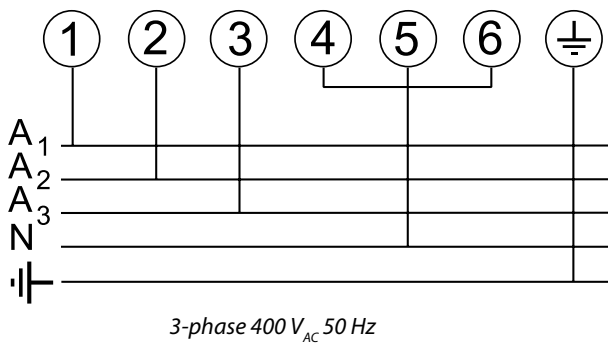
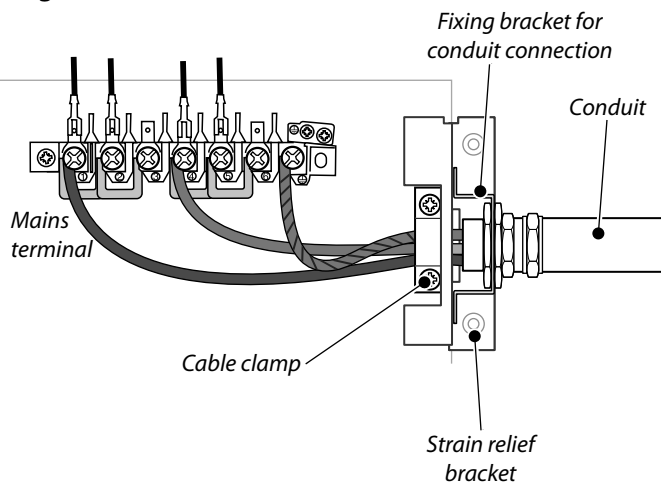

Fig. 9.13



Current Operated Earth Leakage Breakers

The combined use of your cooker and other domestic appliances may cause nuisance tripping, so we recommend that the cooker is protected on an individual RCD (Residual Current Device) or RCBO (Residual Current Breaker with Overload).

IF IN DOUBT, PLEASE CONSULT A SUITABLY QUALIFIED ELECTRICIAN.

The cooker is preset for a single-phase earthed electrical connection. It is essential to install a multi-pole circuit breaker that completely disconnects the appliance from the mains, with a minimum contact break distance of 3 mm.

⚠ WARNING: THIS APPLIANCE MUST BE EARTHED.

The appliance must be connected to an efficient earthing circuit. If the electricity network is not equipped with an earth connection, then it must be installed separately in compliance with local regulations.

Earthing is a safety measure required by law, and must be performed with particular care by a qualified technician, who must also check that the electricity supply characteristics are correct.

The total electrical load of the appliance is approximately 3.6 kW. The cable size used should be suitable for this load and comply with all local requirements.

Access to the mains terminal is gained by removing the electrical terminal cover box on the back panel. Connect the mains cable to the correct terminals for your electrical supply type (**Fig. 9.10** and **Fig. 9.11**). Check that the links are correctly fitted and that the terminal screws are tight. Secure the mains cable using the cable clamp.

An isolation switch shall be provided and mounted near the cooker, in a readily accessible position, in compliance with AS/NZS 3000 and/or AS/NZS 5601 as applicable for the appliance configuration.

Fixed Wiring

For connection to fixed wiring, i.e. flexible conduit, remove the electrical terminal cover box on the back panel. Using the two screws, fix the strain relief bracket in position.

Fix the conduit-to-conduit mounting bracket onto the strain relief bracket. Connect the mains cable to the correct terminals for your electrical supply type (**Fig. 9.12** and **Fig. 9.13**). Check that the links are correctly fitted and that the terminal screws are tight.

Replace the electric terminal cover box; make sure that the conduit is clear of the bottom flange.

Final Checks

Hotplate Check

Check each burner in turn. There is a Flame Supervision Device (FSD) that stops the flow of gas to the burner if the flame goes out. For each burner, turn the control knob to the

INSTALLATION

Check the appliance is electrically safe and gas sound when you have finished.

solid flame symbol. Press in the control knob. This lets gas through to the burner. Keep holding the knob pressed in and press the igniter button or light with a match. Keep holding the control knob pressed in for about 10 seconds.

If, when you let go of the control knob the burner goes out, the safety device has not held in. Wait one minute then try again this time holding the control pressed in for slightly longer.

Oven Check

Turn on the oven and check that it starts to heat up. Check that the oven lights are working.

NOTE: The oven light bulb is not included in the guarantee.

Turn off the oven.

Final Fitting

Fitting the Plinth

Remove the 3 screws for the plinth mounts along the front bottom edge of the range (**Fig. 9.14**). Fasten the plinth using these screws.

Refitting the Oven Door

To refit the door, slide the hinges back into their slots. Rotate the locking 'U' clips back to fit onto the hinges.

Customer Care

INSTALLER: Please complete your details in this guide, inform the user how to operate the cooker and hand over the instructions.

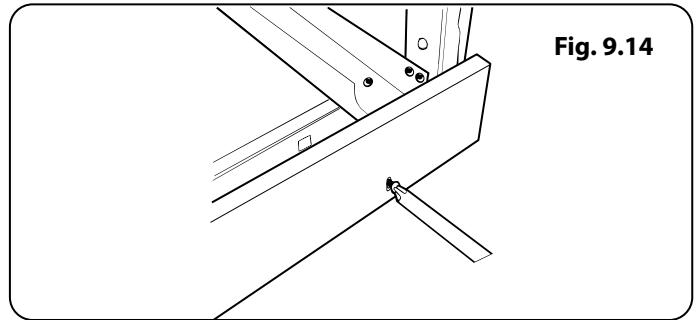

INSTALLATION

Check the appliance is electrically safe and gas sound when you have finished.

Fitting the drawer

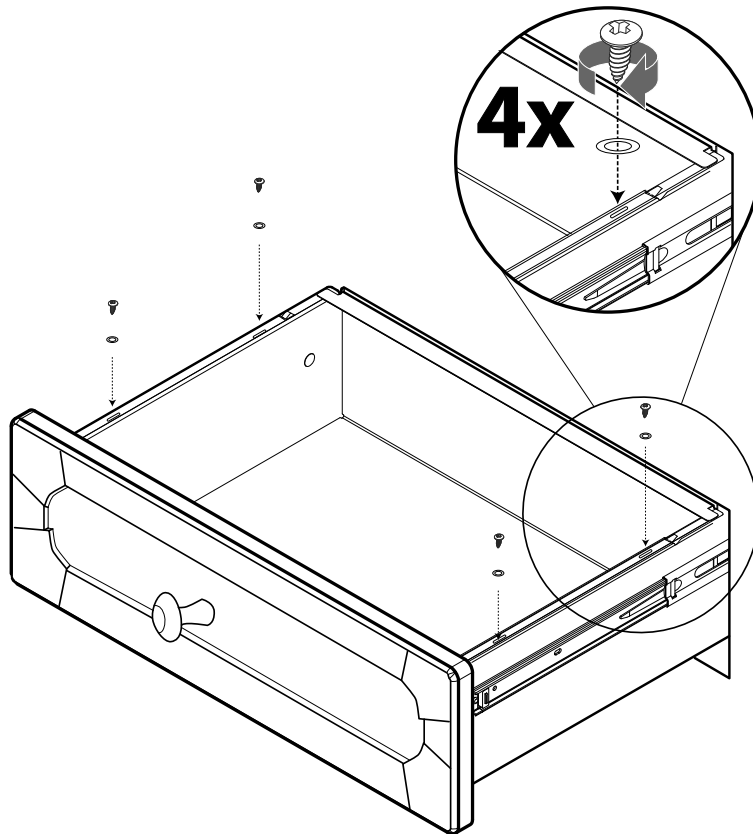

Removing the drawer

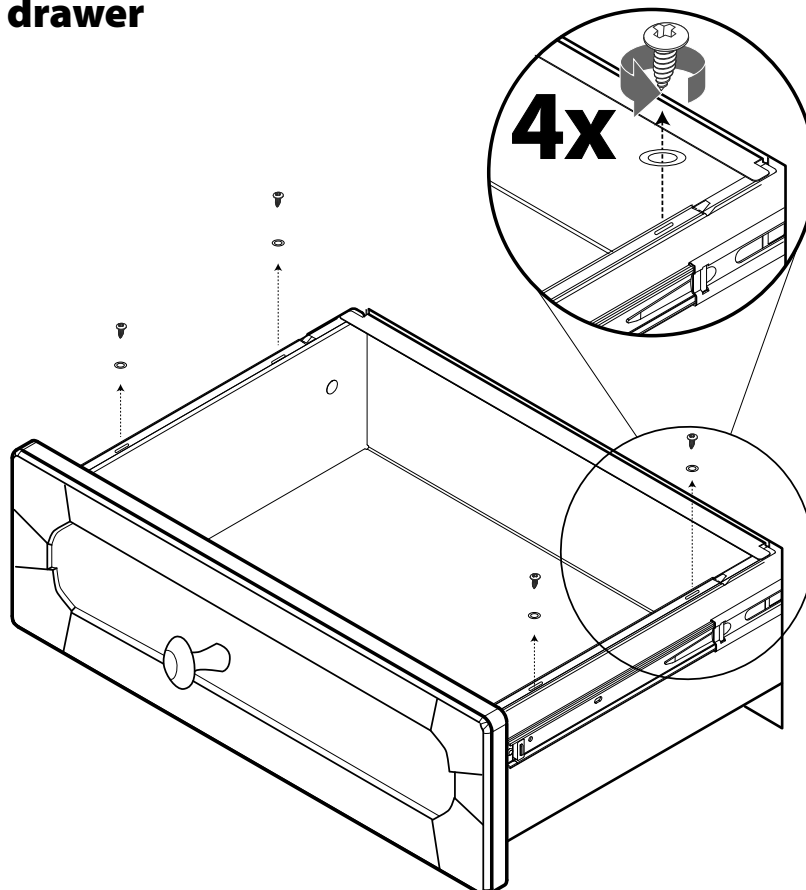

10. Conversion to propane gas

Conversion from Natural Gas (1.0 kPa) to LPG X Propane (2.54 kPa)

- ⚠ A suitably competent person must perform the conversion. After conversion the installation must comply with the relevant regulations and also the local electricity supply company requirements. Read the instructions before converting this appliance.
- ⚠ Failure to convert the appliance correctly could invalidate any warranty or liability claims and lead to prosecution.
- ⚠ The conversion instructions must be used in conjunction with the rest of the appliance instruction, in particular for information on Standards, cooker positioning, connection, hose suitability, etc.
- ⚠ When servicing or replacing gas-carrying components, disconnect from the gas before starting, and check that the appliance is gas sound after completion.
- ⚠ DO NOT use reconditioned or unauthorised gas controls.
- ⚠ Disconnect from the electricity supply before conversion. Before electrical reconnection, check that the appliance is electrically safe.

Injectors

Remove the burner caps and heads. Remove the old jets. Fit the new jets: see 'Technical Data' section for correct jets. Reassemble in the reverse order (Fig. 10.1).

Tap adjustment

DISCONNECT FROM THE ELECTRICITY SUPPLY.

Removing the control panel

Remove all control knobs. Open the oven door. Undo the 4 screws on the oven beak (Fig. 10.2). Remove the 3 fixing screws on the underside of the control. The control panel should drop down slightly. It is held at each end by two holes in the top edge (Fig. 10.3) that locate on the tags on the inner panel.

Lift the control panel clear of the tags and pull the control panel forward.

Take care not to damage or strain the wiring.

Bypass screw adjustment

Turn the bypass screw on each control clockwise to the stop (Fig. 10.4).

Refit the control panel.

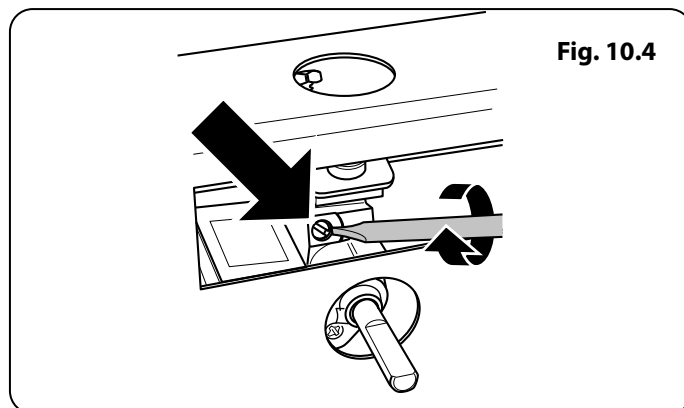
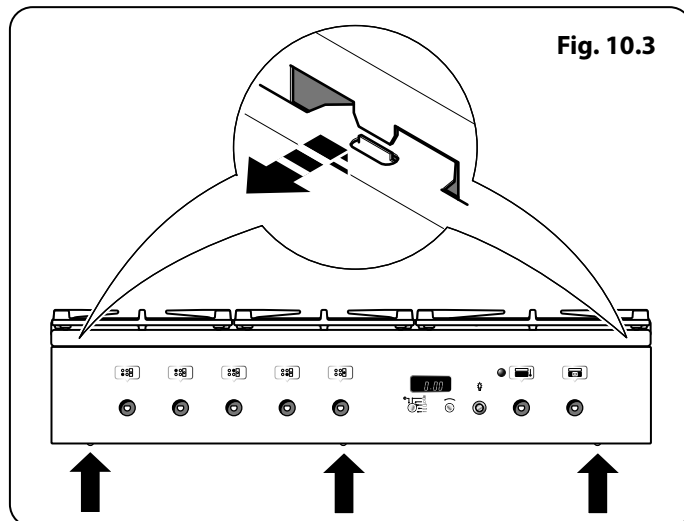
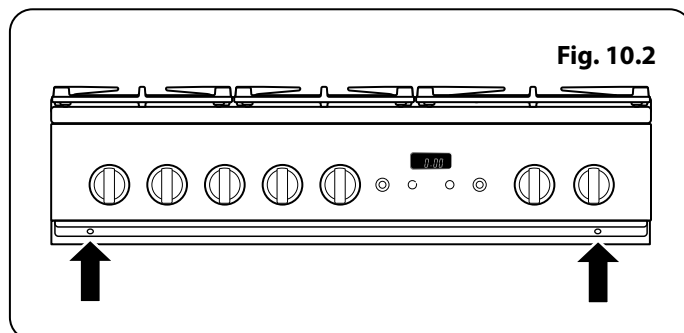
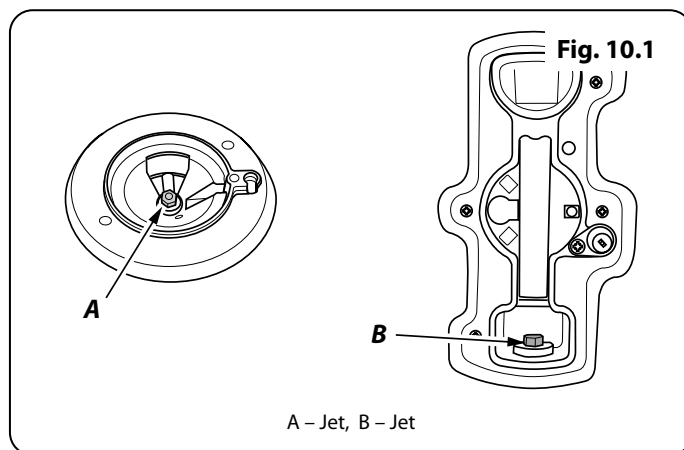

WARNING – SERVICING TO BE CARRIED OUT ONLY BY AN AUTHORISED PERSON
Disconnect from electricity and gas before servicing. Check appliance is safe when you have finished.

Fig. 10.5

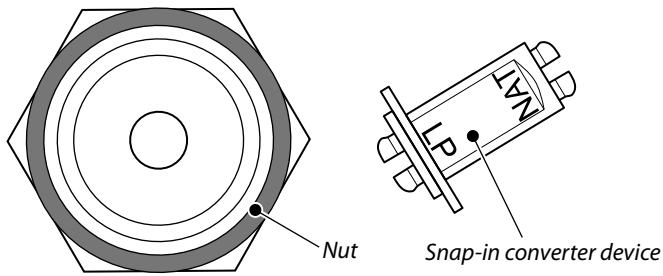

Set the governor

Unscrew the governor's brass top. In the base of the brass top is a plastic snap-in converter device (**Fig. 10.5**). To convert the governor, snap the device out of the top and refit it the other way round. The snap-in converter device is marked to show the gas for which it is set (**Fig. 10.6**).

Make sure the device is secure in the top cap and refit the cap to the governor.

Pressure testing

The pressure test point is accessible on the inlet pipe at the rear. Remove the test nipple screw and fit a pressure gauge to the test point. Turn on and light two of the hotplate burners.

For Propane X cookers the pressure should be 2.54 kPa.

Fig. 10.6

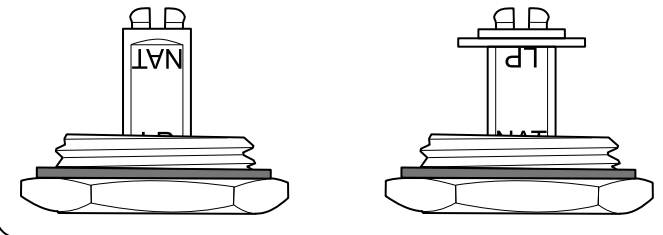

Affix label

Stick the appropriate gas label over the natural gas part of the appliance data labels (one on the rear of the appliance and one in the storage drawer).

⚠ Check the appliance is gas sound.

⚠ Check operation of all the burners.

WARNING – SERVICING TO BE CARRIED OUT ONLY BY AN AUTHORISED PERSON
Disconnect from electricity and gas before servicing. Check appliance is safe when you have finished.

11. Servicing

- ⚠ BEFORE SERVICING ANY GAS CARRYING COMPONENTS TURN OFF THE GAS SUPPLY**
- ⚠ Check the appliance is gas sound after completion of service. When checking for gas leaks do not use washing up liquid – this can corrode. Use a product specifically manufactured for leak detection.**
- ⚠ DO NOT use reconditioned or unauthorised gas controls.**
- ⚠ Disconnect from the electricity supply before servicing, particularly before removing any of the following: control panel, side panels, hotplate tray or any electrical components or covers.**
- ⚠ Before electrical reconnection, check that the appliance is electrically safe.**

1. Panels

1. To Remove the Control Panel

DISCONNECT FROM THE ELECTRICITY SUPPLY.

Remove the control knobs. Open the oven door. Undo the screws holding the oven beak to the cooker and remove (**Fig. 11.1**).

Remove the fixing screws on the underside of the control. The control panel should drop down slightly. It is held at each end by 2 holes in the top edge (**Fig. 11.2**) that locate on the tags on the inner panel.

Lift up the control panel so that it is clear of the tags and pull the control panel forwards (**Fig. 11.3**).

Disconnect the wiring from the rear. Lift the panel clear of the cooker.

Replace all parts in reverse order. When replacing any electrical connections refer to the wiring diagram.

2. To Remove the Side Panels

DISCONNECT FROM THE ELECTRICITY SUPPLY.

Remove the control panel (see **1. To Remove the Control Panel**). Undo the 3 screws securing the plinth to the cooker and remove.

Situated below the edge at the panel front corner is the lower retaining screw. Remove this screw.

Remove the side panel retaining screw on the upper front edge, and undo the 2 fixings on the rear of the side panel.

Remove the panel by pulling it away from the cooker.

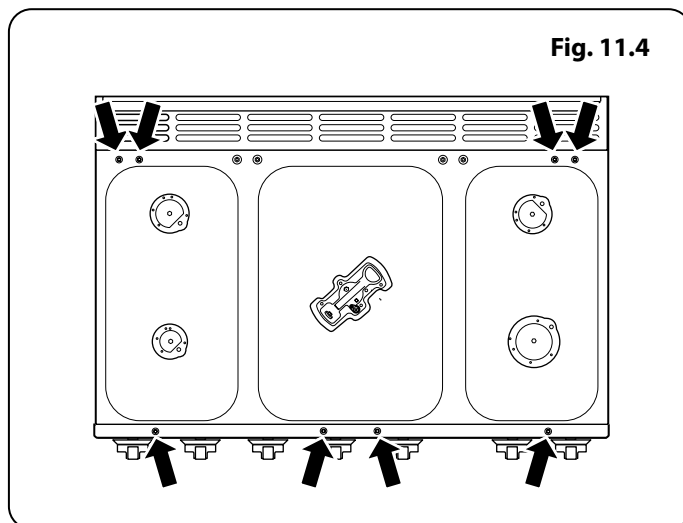
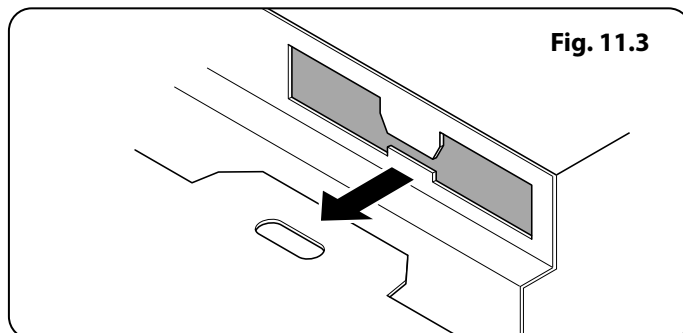
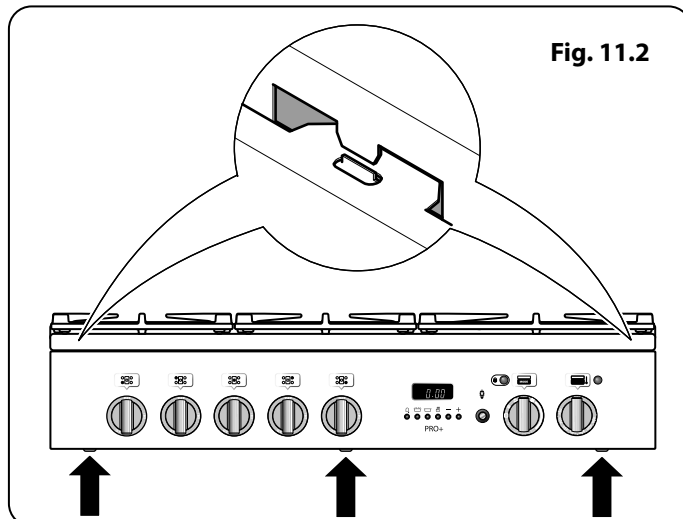
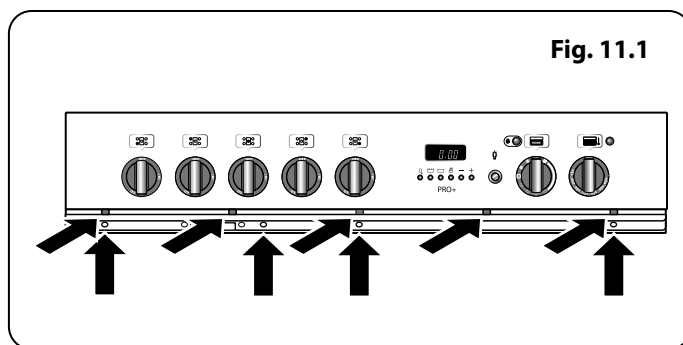

WARNING – SERVICING TO BE CARRIED OUT ONLY BY AN AUTHORISED PERSON
Disconnect from electricity and gas before servicing. Check appliance is safe when you have finished.

2. Hotplate

1. To Remove the Hotplate

DISCONNECT FROM THE ELECTRICITY SUPPLY.

Remove the pan supports and burner heads.

Remove the 10 screws (2 per burner) holding the hotplate burners to the hotplate. Remove the 8 screws holding the hotplate tray to the cooker (**Fig. 11.4**).

Taking care not to damage the burner heads, lift the hotplate clear of the cooker.

Reassemble in reverse order, making sure that the leads are reconnected correctly. Check the operation of each burner.

2. To Replace the Hotplate Control Taps

DISCONNECT FROM THE ELECTRICITY SUPPLY.

Remove the control panel (see **1. To Remove the Control Panel**) and hotplate (see **1. To Remove the Hotplate**).

Unplug the FSD lead from the rear of the tap. Undo compression fitting at the rear of the tap. Remove the fixings that secure the tap to the gas rail.

Disconnect the ignition switch wiring. Remove the tap, then remove and discard the gasket seal.

Fit the new gasket seal to the replacement tap.

Reassemble in reverse order. Check the cooker is gas sound. Check the hotplate ignition.

3. To Change a Hotplate Burner Injector

DISCONNECT FROM THE ELECTRICITY SUPPLY.

Remove the pan supports, burner cap and head. Remove the old jet. Fit the new injector.

Reassemble in reverse order. Check the cooker is gas sound.

4. To Replace a Hotplate Burner Electrode

DISCONNECT FROM THE ELECTRICITY SUPPLY.

Lift off the pan supports and remove the burner cap. Remove the screw holding the electrode. Pull the electrode vertically up sufficiently to grip the lead between thumb and forefinger. Pull off the electrode but keep hold of the lead.

Fit the new electrode to the lead and fix the electrode to the burner. Replace the burner cap. Check the burner ignition.

5. To Replace a Hotplate Burner

DISCONNECT FROM THE ELECTRICITY SUPPLY.

Remove the hotplate (see **1. To Remove the Hotplate**).

All of the burners (except the wok burner) are mounted on support struts. Disconnect the burner feed pipes at the burner. Remove the screws at the front and rear holding the support struts. Lift the strut and burners clear. The burners are fixed to the support struts with 2 screws.

Remove the appropriate burner and fit the new one. Reassemble in reverse order. Check that the burner operation is satisfactory.

Wok Burner

Disconnect the burner feed pipes at the burner. Fit the new one and reassemble in reverse order. Check that the burner operation is satisfactory.

1. To Replace a Hotplate Burner Thermocouple

DISCONNECT FROM THE ELECTRICITY SUPPLY.

Remove the hotplate (see **1. To Remove the Hotplate**).

Identify the thermocouple to be removed. Pull off the connection at the tap end and lift the thermocouple away at the burner end.

Fit the new thermocouple in the reverse order.

Replace the hotplate. Check the thermocouple for correct operation at full rate and turndown.

3. Controls

1. To Replace the Ignition or light Switch

DISCONNECT FROM THE ELECTRICITY SUPPLY.

Remove the control panel (see **1. To Remove the Control**).

NOTE: The old switch may be destroyed during removal.

Remove the switch button and old switch from its bezel by gripping the switch body behind the control panel and twisting sharply. Remove the switch bezel by folding back the locking wings and pushing forwards.

Fit the new bezel to the control panel by first lining up the raised key on its body with the cut-out in the control panel and pushing it in from the front. Assemble the new switch to the bezel by lining up the key sections and pushing home.

Fit the new button by pushing in from the front.

Replace control panel in reverse order and test for correct operation.

2. To Replace the Clock

DISCONNECT FROM THE ELECTRICITY SUPPLY.

Remove the control panel (see **1. To Remove the Control Panel**). Pull off the timer control buttons.

Undo the timer/mounting bracket assembly fixing screws and remove the assembly from the control panel.

Remove the timer from its mounting bracket by depressing the plastic lugs on the timer case, while at the same time pulling the unit forward.

Reassemble in reverse order. When replacing the leads, refer to the wiring diagram.

Check the operation of the timer.

WARNING – SERVICING TO BE CARRIED OUT ONLY BY AN AUTHORISED PERSON
Disconnect from electricity and gas before servicing. Check appliance is safe when you have finished.

3. To Replace the Ignition Spark Generator

DISCONNECT FROM THE ELECTRICITY SUPPLY.

Remove the hotplate (see **1. To Remove the Hotplate**).

Disconnect all the leads from the generator, taking note of their positions. Unclip the generator from the cooker.

Fit the new generator and reconnect the leads. Check for correct ignition.

4. Ovens

1. To Change an Oven Thermostat

DISCONNECT FROM THE ELECTRICITY SUPPLY.

Situated at the back of the oven, behind the right-hand upper elements, are the primary and protection thermostats phials. One on the right-hand side of the same element is the pyrolytic phial (**Fig. 11.5**).

To Change the Primary Thermostat

Remove the control panel (see **1. To Remove the Control**) and hotplate (see **1. To Remove the Hotplate**).

Remove the oven shelves, shelf supports and divider.

Undo the cooker rear cover screws and remove the covers.

Undo the screw holding the phial retaining clamp to the bracket. Undo the 2 screws securing the catalytic filter cover (**Fig. 11.6**).

Track the route of the thermostat capillary from the rear of the control on the fascia to where it disappears into the oven. By moving the capillary it will become obvious which of the 2 phials in the oven it is connected to. The phial can then be removed.

Feed the thermostat capillary out and clear of the oven, noting the routing.

Remove the 2 screws fixing the thermostat to the inner control panel and disconnect the wiring from the thermostat.

Fit the replacement in reverse order.

To Change the Protection Thermostat

Follow the same procedure as above except that the control is situated on the rear cover.

Fit the replacement in reverse order.

To Change the Pyrolytic Thermostat

Remove the control panel (see **1. To Remove the Control**) and hotplate (see **1. To Remove the Hotplate**).

Remove the oven shelves, shelf supports and divider.

Undo the cooker rear cover screws and remove the covers.

Remove the 2 screws holding the small retaining plate on the back of the cooker and remove the plate.

Remove the pyrolytic phial.

Fit the replacement in reverse order.

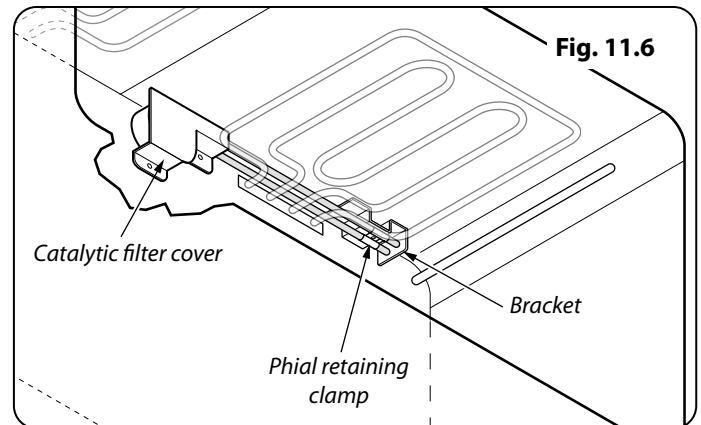
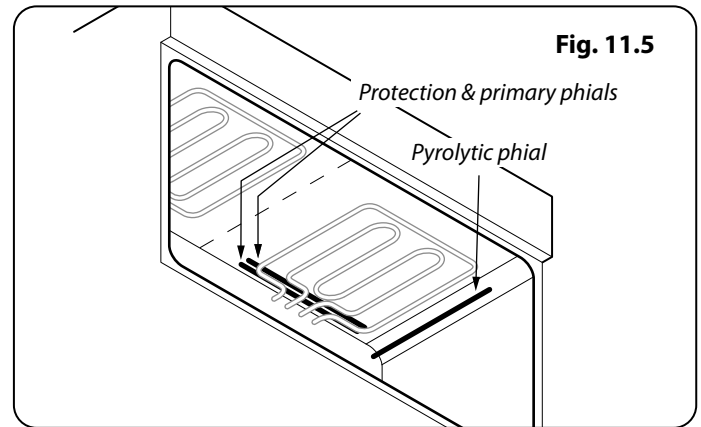

WARNING – SERVICING TO BE CARRIED OUT ONLY BY AN AUTHORISED PERSON
 Disconnect from electricity and gas before servicing. Check appliance is safe when you have finished.

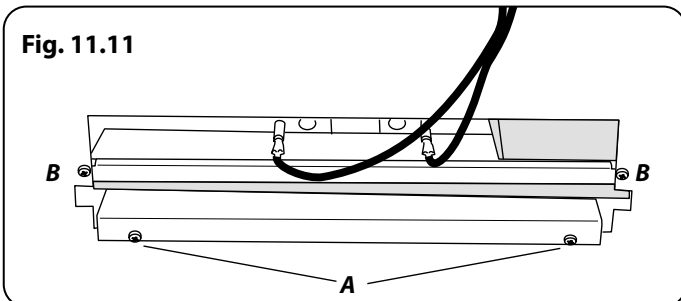
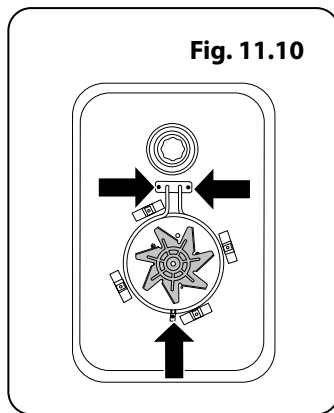
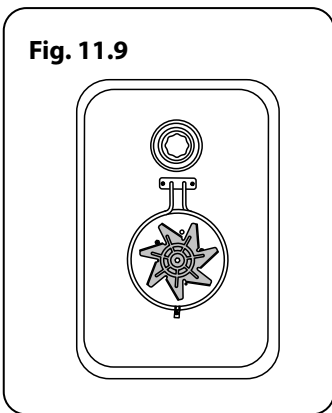
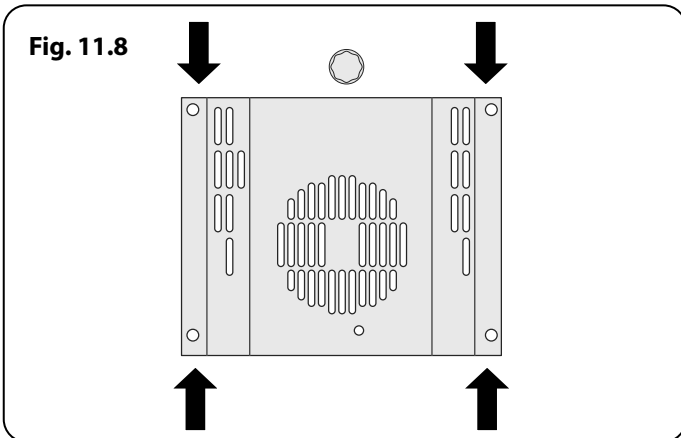
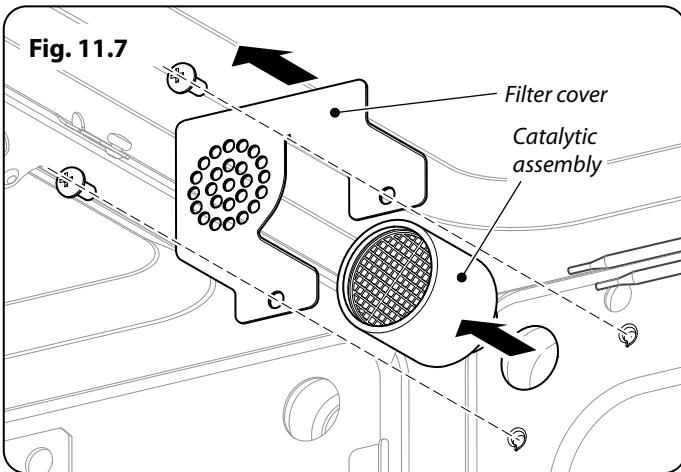

2. To Replace the Oven Multi-function Switch
DISCONNECT FROM THE ELECTRICITY SUPPLY.

Move the cooker away from the wall to allow access to the rear.

Remove the control panel (see **1. To Remove the Control Panel**) and hotplate (see **1. To Remove the Hotplate**).

Remove the fixing screws from the front of the oven multi-function switch. Disconnect the leads and remove the switch.

Fit the new switch.

3. To Replace the Oven Catalytic Converter
DISCONNECT FROM THE ELECTRICITY SUPPLY.

Undo the 2 screws holding the catalytic filter cover in place (**Fig. 11.7**) and remove.

Pull out the catalytic assembly.

Replace the catalyst and fit in reverse, making sure that the cover fits over the ends of the thermostat phials.

4. To Remove an Oven Inner Back Panel

DISCONNECT FROM THE ELECTRICITY SUPPLY.

Open the oven door. For the right-hand side unscrew the 4 thermostat phial fixing screws.

Remove the fixings that secure the inner back to the oven rear (**Fig. 11.8**). Lift the removable panels away.

Reassemble in reverse order. Make sure that the retaining fixings are fully tightened.

5. Replacing an Oven Fan

DISCONNECT FROM THE ELECTRICITY SUPPLY.

Pull the cooker forward to access the cover boxes at the rear of the cooker.

Remove the inner back panel (see **4. To Remove an Oven Inner Back Panel**).

Hold the fan blades and undo the centre nut (Left-hand thread), brass washers, fan blade and circlip (**Fig. 11.9**). Undo the screws that retain the fan and remove it from the cavity rear.

Fit the replacement and reassemble the parts in reverse order.

Check that the oven operates satisfactorily.

6. Replacing an Oven Fan Element

DISCONNECT FROM THE ELECTRICITY SUPPLY.

Remove the inner back panel (see **4. To Remove an Oven Inner Back Panel**).

Remove the screws that secure the element within the oven and carefully lift the element away (**Fig. 11.10**).

Disconnect the leads and connect to the replacement element and reassemble the parts in reverse order.

WARNING – SERVICING TO BE CARRIED OUT ONLY BY AN AUTHORISED PERSON
Disconnect from electricity and gas before servicing. Check appliance is safe when you have finished.

7. 4.7 To Replace the Top and Bottom Elements

DISCONNECT FROM THE ELECTRICITY SUPPLY.

Bottom Element

Pull the cooker forward to allow access to the cover boxes at the rear. Remove the fixings that secure the cover and lift it clear.

Remove the 2 screws 'A' and allow the plate to drop down. Remove the 2 screws 'B', and then lower the upper plate and remove it through the slot in the cooker back (**Fig. 11.11**).

Undo the terminal connections, noting their positions. Remove the element fixings and withdraw the element.

Replace the element and reassemble the parts in reverse order.

Top Element

Remove the top element bracket fixings and withdraw the elements carefully, lifting to clear the clips on the support bar (**Fig. 11.12**).

Replace the element and reassemble the parts in reverse order.

Check that the oven operates satisfactorily.

8. To Replace the Cooling Fan

Remove the hotplate (see **1. To Remove the Hotplate**).

Remove the access plate.

Remove the screws that hold the cooling fan to the duct (**Fig. 11.13**), and then lift out the fan.

Reassemble in reverse order.

9. To Replace the Oven Latch Motor

Remove the packing and accessories from the appliance except the base pack that can be left in place.

Remove the hotplate (see **1. To Remove the Hotplate**).

Disconnect the thermal cut-out. Disconnect the motor leads from the terminal block.

Undo the 3 cover plate screws and remove the plate.

Open the oven door and undo the 2 latch assembly retaining screws (**Fig. 11.14**).

Remove the black, orange and purple wires connected to the latch motor. Remove the latch motor assembly.

NOTE: The access to the assembly is very tight; it is suggested that the assembly is slid into the cooker so that the latch can be turned sideways and then lifted out front first.

Replace the motor and refit in reverse order.

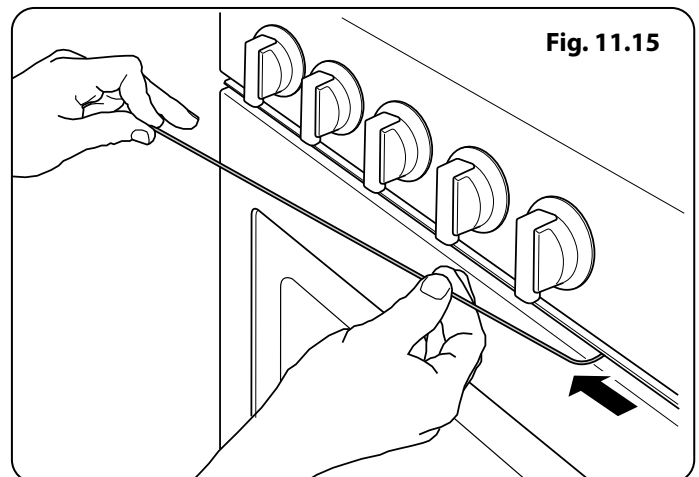
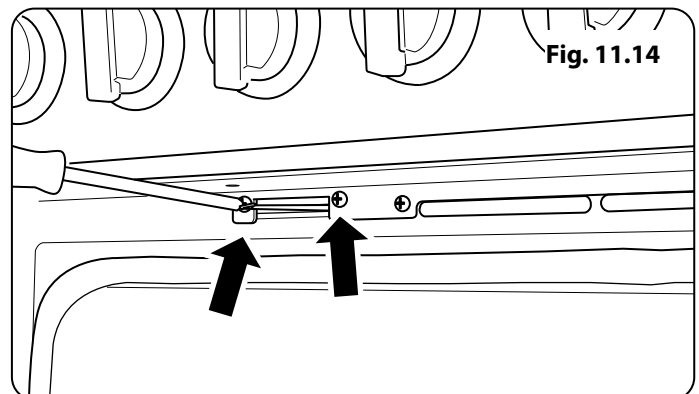
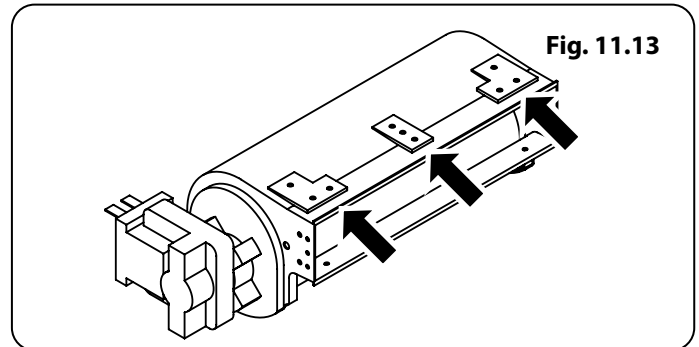
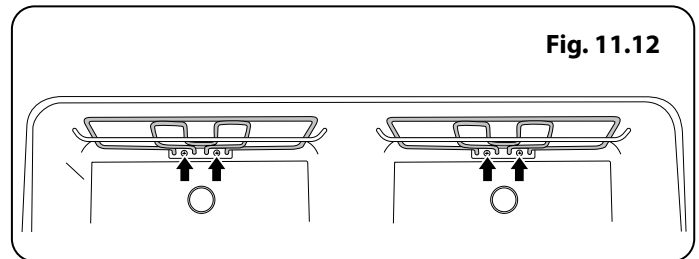

WARNING – SERVICING TO BE CARRIED OUT ONLY BY AN AUTHORISED PERSON
Disconnect from electricity and gas before servicing. Check appliance is safe when you have finished.

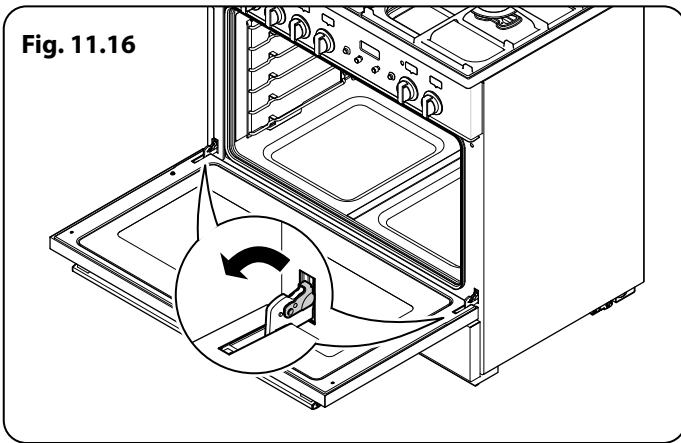

10. To Override a Locked Oven

Switch on the cooker. Set the oven function control to self-clean – do not set the timer. This should switch the lock back to the open position.

If this fails, then get a wire hook and slide in through the side to pull the latch back (**Fig. 11.15**).

5. Door

1. To Remove the Oven Door

CAUTION! The door is very heavy. Take care when removing.

To remove the door, open the door fully.

Swivel the locking 'U' clips forward to the locking position (**Fig. 11.16**). Grip the sides of the door, lift upwards and then slide the door forwards (**Fig. 11.17**) and remove.

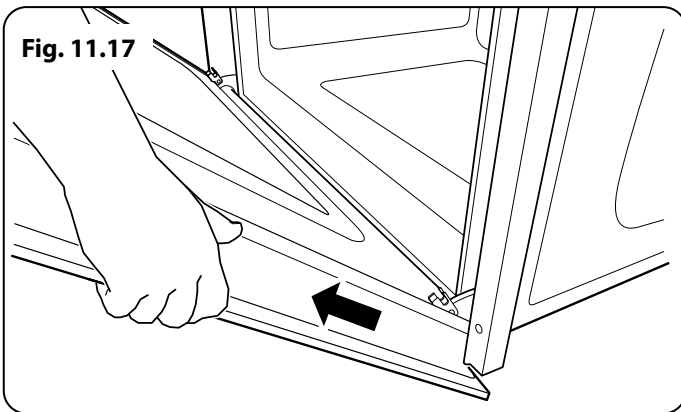

2. To Remove the Outer Panel

Undo the 4 screws (2 each side) in the door (**Fig. 11.18**). Open the door slightly and, using the handle, lift the door outer away.

To refit the door, first close the door inner. Lift the door outer panel onto the door inner, – make sure the top of the door outer panel fits over the locking mechanism before locating the sides. Secure in position.

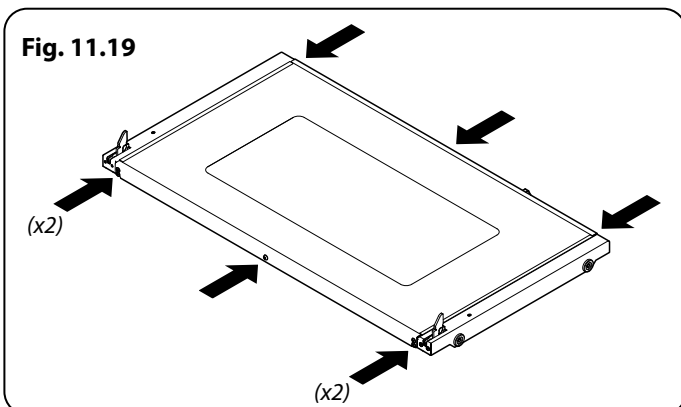
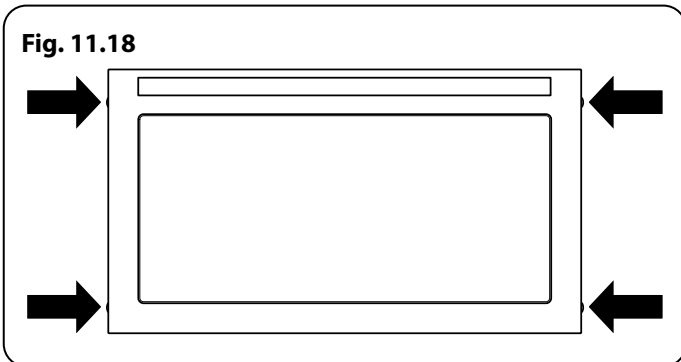

WARNING – SERVICING TO BE CARRIED OUT ONLY BY AN AUTHORISED PERSON
Disconnect from electricity and gas before servicing. Check appliance is safe when you have finished.

3. To Replace the Door Glass Panel

Remove the oven door (see **1. To Remove the Oven Door**).

To remove the inner door glass panel, carefully place the door, outer side up, on a clean level surface. Undo the 3 retaining screws in the top of the door and remove the trim. Undo the 5 retaining screws from the lower edge of the door and remove the bottom trim (**Fig. 11.19**). Lift out the glass panel.

To remove the centre glass, carefully place the door, inner side up, on a clean level surface. Remove the outer door panel (see **2. To Remove the Outer Panel**).

Undo the 8 screws holding the centre glass panel assembly in place (**Fig. 11.20**). Lift out the centre glass panel assembly, gasket and inner centre glass panel.

Reassemble in reverse order.

4. To Replace the Oven Door Hinge

Remove the oven door (see **1. To Remove the Oven Door**).

Lift out the inner panel and place it, outer side up, on a clean level surface. Undo the screws securing the hinge in place. Remove the hinge.

Replace the hinge and rebuild the door in reverse order.

5. To Replace the Oven Door Seal

Open the oven door. The seal is held in place by small spring clips to the cooker front. At the corner, squeeze the clip and pull the seal diagonally away from the door centre until that clip is released (**Fig. 11.21**).

Proceed to the next clip and release it in a similar way, and so on. Use force if the clips are stiff, as the old seal will be discarded.

When fitting the new seal, position the seal join at the bottom. Clip the new seal in one of the corner holes of the door, and proceed round the door snapping in each spring clip in turn.

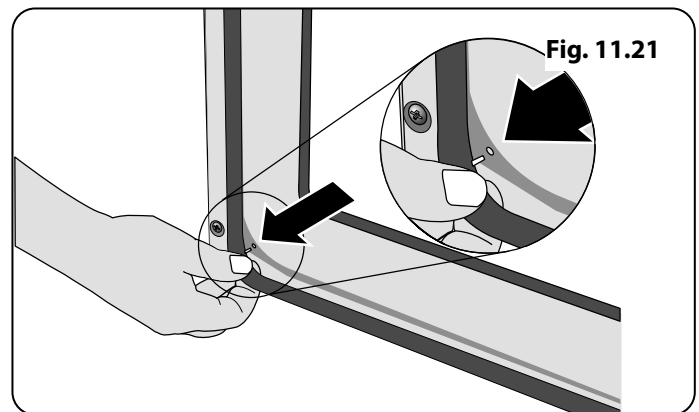
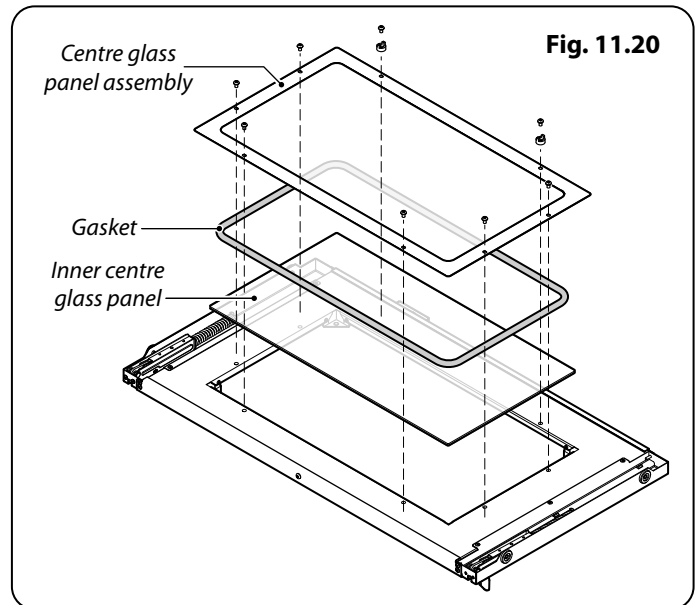

12. Circuit Diagram

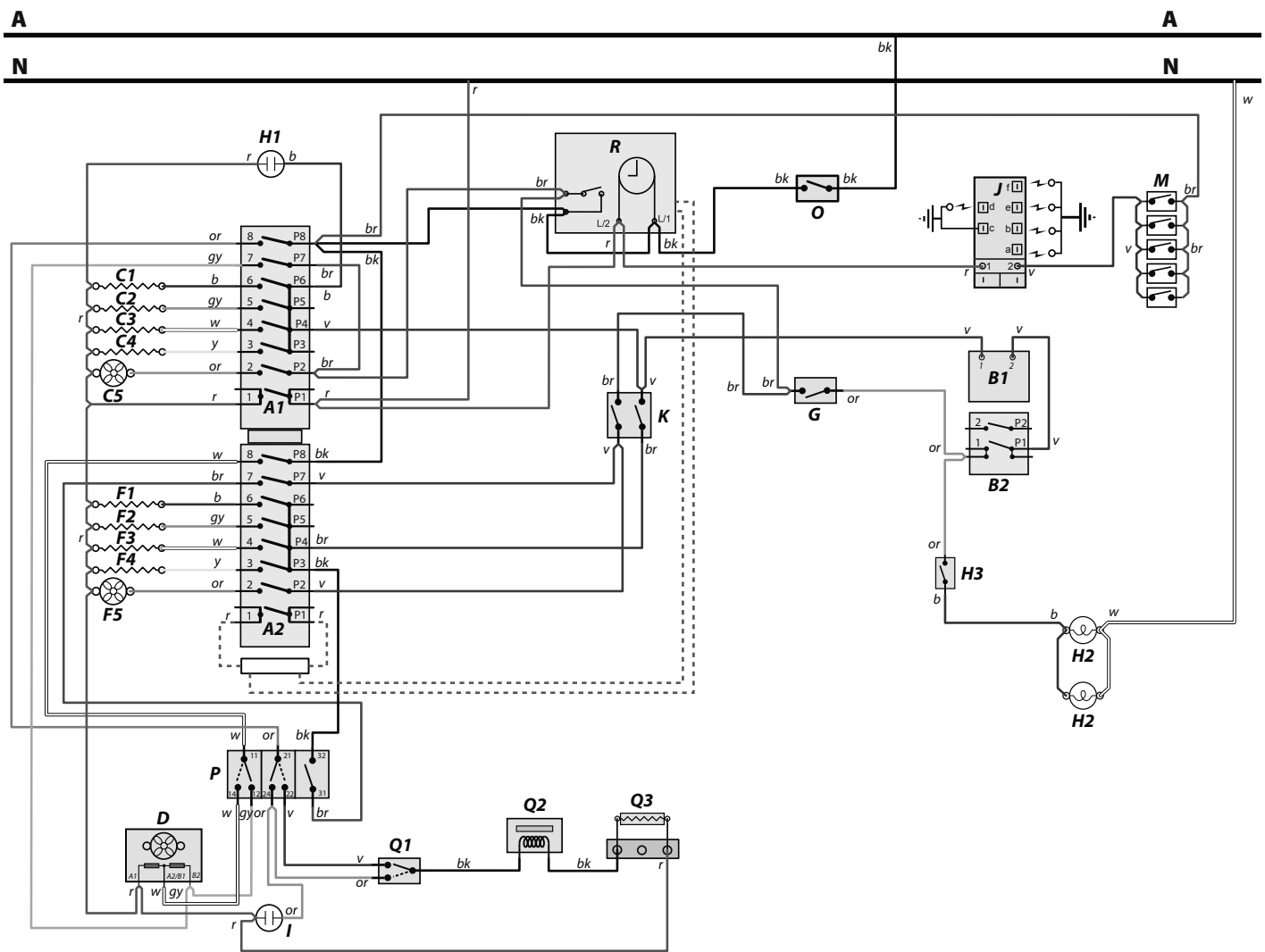

Code	Description
A1	Multi-function oven master switch
A2	Multi-function oven drone switch
B1	Oven thermostat
B2	Oven front switch
C1	Right-hand oven base element
C2	Right-hand oven top outer element
C3	Right-hand oven top inner element
C4	Right-hand oven fan element
C5	Right-hand oven fan
D	Cooling fan (2 speed)
F1	Left-hand oven base element
F2	Left-hand oven top outer element
F3	Left-hand oven top inner element
F4	Left-hand oven fan element
F5	Left-hand oven fan

Code	Description
G	Oven protect thermostat
H1	Oven neon
H2	Oven light
H3	Oven light switch
I	Door lock neon
J	Ignition spark generator
K	Oven divider switch (In)
M	Ignition switches
O	Cooling fan fail cut-out
P	Pyrolytic thermostat
Q1	Lock cam switch
Q2	Lock motor
Q3	Lock motor resistor
R	Clock / oven timer

Code	Colour
b	Blue
br	Brown
bk	Black
or	Orange
r	Red
v	Violet
w	White
y	Yellow
gy	Green/yellow
gr	Grey
r(f)	Red (flag)

13. Technical Data

This cooker is designed for use on Natural gas, although a conversion for LP (LPG X Propane (2.54 kPa)) gas is packed with the cooker.

INSTALLER: Please leave these instructions with the user.

DATA BADGE LOCATION: Inside base drawer of cavity and on rear of the appliance.

COUNTRY OF DESTINATION: Australia.

Connections

Gas (Rp ½ at rear right-hand side)		Electric
Natural Gas	1 kPa	230V 50 Hz
Propane	2.54 kPa	

See the appliance badge for test pressures.

Dimensions

Model	Professional+ FX 90 Dual Fuel	
Overall height	minimum 905 mm	maximum 930 mm
Overall width	900 mm	
Overall depth	608 mm excluding handles, 645 mm including handles	
Minimum height above the hotplate	650 mm	

Hotplate Ratings

BSI Evo 1 Type Burners Australia							
Burner Type	Bypass Screw*	Natural Gas 1.0 kPa			Propane 2.54 kPa		
		Input	Injector		Input	Injector	
			Marking	Size Ø		Marking	Size Ø
Wok	75	15.2 MJ/h ⁻¹	198	1.93 mm	15.0 MJ/h ⁻¹	111	1.07 mm
Rapide / Large	41	12.3 MJ/h ⁻¹	165	1.65 mm	12.0 MJ/h ⁻¹	89	0.96 mm
Semi Rapide / Medium	33	6.2 MJ/h ⁻¹	115	1.15 mm	6.2 MJ/h ⁻¹	67	0.68 mm
Auxillary / Small	25	3.7 MJ/h ⁻¹	92	0.92 mm	3.3 MJ/h ⁻¹	45	0.50 mm

* The valves in this cooker are fitted with adjustable bypass screws. The cooker is supplied with the bypass screws set for Natural gas. For LPG conversion the bypass screws must be screwed all the way down.

Hotplate energy saving tips

- Use cookware with a flat base.
- Use the correct size cookware.
- Use cookware with a lid.
- Minimise the amount of liquid or fat.
- When liquid starts boiling, reduce the setting.
- Consumption is based on G30.

Oven energy saving tips

- Cook meals together, if possible.
- Keep the pre-heating time short.
- Do not lengthen cooking time.
- Do not open the oven door during the cooking period.
- Do not forget to turn the appliance off at the end of cooking.

Hotplate Efficiency

Brand	Falcon
Model Identification	Professional+ FXP
Size	90 Single Cavity
Type	Dual Fuel

Type of Hob	GAS
Number of gas burners	5
Auxiliary / Small Burner (EE gas burner)	-
Semi Rapide / Medium Burner (EE gas burner)	58%
Semi Rapide / Medium Burner (EE gas burner)	58%
Rapide / Large Burner (EE gas burner)	56%
Rapide / Large Burner (EE gas burner)	-
Wok (EE gas burner)	54%
Wok (EE gas burner)	-
Hotplate EE gas hob (*)	56%

Information marked thus (*) is not required with mixed fuel hobs

Oven Data

Brand		Falcon
Model identification		Professional+ FXP
Type of oven		Electric
Mass	kg	133
Number of cavities		1
Single Cavity		
Fuel type		Electric
Cavity type *Drop Down Door		Multifunction*
Power - conventional		2.75
Power - forced air convection		3.3
Volume	Litres	114
Energy consumption (electricity) - conventional	kWh / cycle	1.22
Energy consumption (electricity) - forced air convection	kWh / cycle	1.05
Energy efficiency index - conventional		118.6
Energy efficiency index - forced air convection		102.1
Energy class		A

Additional Information		
The oven complies with EN 60350-1		
Maximum output @ 230V 50Hz	Full	Divided
Fan element	3.31 kW	1.65 kW
Top element	3.49 kW	1.75 kW
Browning element	2.11 kW	1.06 kW
Bottom element	1.38 kW	0.69 kW

Maximum total electrical load at 230 V (approximate total including hob, oven lights, oven fan, etc.)	3.6 kW
--	--------

Clarence Street, Royal Leamington Spa,
Warwickshire, CV31 2AD, England.
www.falconworld.com