

# FETCO® User's Guide and Operator Instructions

## CBS-2251, CBS-2252 & CBS-2253 Next Generation Brewing System FETCO Next Generation-NG® Commercial Beverage Equipment



CBS-2251

(Dispensers not included)



CBS-2252

(Plastic brew baskets are standard, brewers available with optional stainless steel brew baskets)



### CONTACT INFORMATION

FETCO® FOOD EQUIPMENT TECHNOLOGIES COMPANY  
600 ROSE ROAD  
LAKE ZURICH • IL • 60047-0429 • USA  
Product made in USA  
INTERNET: [www.fetco.com](http://www.fetco.com)  
PATENTS: <https://www.fetco.com/pl/pages/patents,74.html>  
©2020-2024  
FOOD EQUIPMENT TECHNOLOGIES COMPANY



[fetco.com](http://fetco.com)

PHONE: (800) 338-2699 (US & CANADA)  
(847) 719-3000 (All Countries and International)  
FAX: (847) 719-3001  
EMAIL: [sales@fetco.com](mailto:sales@fetco.com)  
[orders@fetco.com](mailto:orders@fetco.com) (to order parts and equipment)  
[techsupport@fetco.com](mailto:techsupport@fetco.com) (all service queries)  
P195 January 2024

### COFFEE BREWER CBS-2250NG Series

#### TABLE OF CONTENTS

Weights and Capacities .....	2	How to calibrate the flow rate for FETCO brewers ....	11
Rough-In Drawings .....	2	Outputs .....	12
Brew Recipes .....	6	Counters .....	13
Settings .....	7	Brewer Setup .....	14
Inputs .....	8	Installation Guide .....	15
Service .....	8	Operator Training .....	16
Error Codes .....	9	Parts diagrams CBS-2252 .....	18
Hot Water Portions .....	10	Parts Diagrams CBS-2251 .....	22
Calibration .....	11	Wiring Diagrams .....	29

## Specifications and Requirements

FETCO CBS-2250 Brewers have unique construction only available for these models.

<b>Water Requirements:</b>	<b>Coffee Filter Size:</b>
CBS-2250 20-75 psig, (138-517kPa) 1½ gpm/(5.7 lpm)	15" X 5 ½" – standard FETCO # F001
Optimal water hardness between 125-250 TDS (6-13 grain) Important! Please use a water filter for all beverage equipment	<b>Temperature, as set by factory:</b> 200°F (93°C) inside water tank (at sea level)
<b>Water inlet fitting:</b> 3/8 inch male flare.	<b>Electrical:</b> See electrical configuration chart Pg 3.
<b>Brew Volume: Full Batch</b> CBS-2250: 1 ½ gallon/ 5.6 liters CBS-2252-2: 2 gallons 7.5 liters	
Brew Capacity (approximate)	Output is controlled by heater power and water temperature
CBS-2251 7-10 brews per hour	
CBS-2252 7-22 brews per hour	
<b>Total Brew Cycle:</b> Factory setting: 6 minutes consisting of 4 min. brew time and 2.0 min. drip delay	
<b>Individual menu brew-process parameters are user controllable for:</b>	
Basic user controls for brew volume, brew time, units of measure, recipe name	
Advanced user controls for pulse count, prewet percent and prewet delay, drip delay, programmable energy saving	
See pages 4-5 for how to adjust controls for temperature, brew volume, units - and all other settings	

### Weights and Capacities

Model	Height	Width	Depth	Water tank capacity	Empty Weight	Filled Weight	Shipping Weight	Shipping Dimensions
CBS-2251 1½ gal	36 7/8 in 940 mm	12 3/4 in 320 mm	22 1/2 in 570 mm	6.5 gallon 24.4 L	53 lbs 24 kg	107 lbs 48.3kg	63 lbs 28.6 kg	38" x 18" x 24" 96.5 x 45.7 x 61 cm
CBS-2252 1½ gal	36 7/8 in 940 mm	21 7/8 in 550 mm	22 1/2 in 570 mm	11.1 gallon 42.1 L	77 lbs 35.0 kg	174 lbs 78.9 kg	97 lbs 44 kg	38" x 24" x 27" 96.5 x 61 x 68.6 cm
CBS-2253 2 gal	39 in 99.1 mm	21 7/8 in 550 mm	22 1/2 in 570 mm	11.1 gallon 42.1 L	82 lbs 37.2 kg	180 lbs 81.6 kg	97 lbs 44 kg	40" x 24" x 27" 102 x 61 x 68.6 cm
CBS-2251 & CBS-2252 Calibrated for 1½ gallons/ 6 liters		CBS-2253 Calibrated for 2 gallons/ 8 liters	Filter Paper all models 15" X 5 ½" – standard Or use FETCO # F001		Brewers ship with plastic brew baskets. See page 25 for optional brew baskets			

### Rough-In Drawings

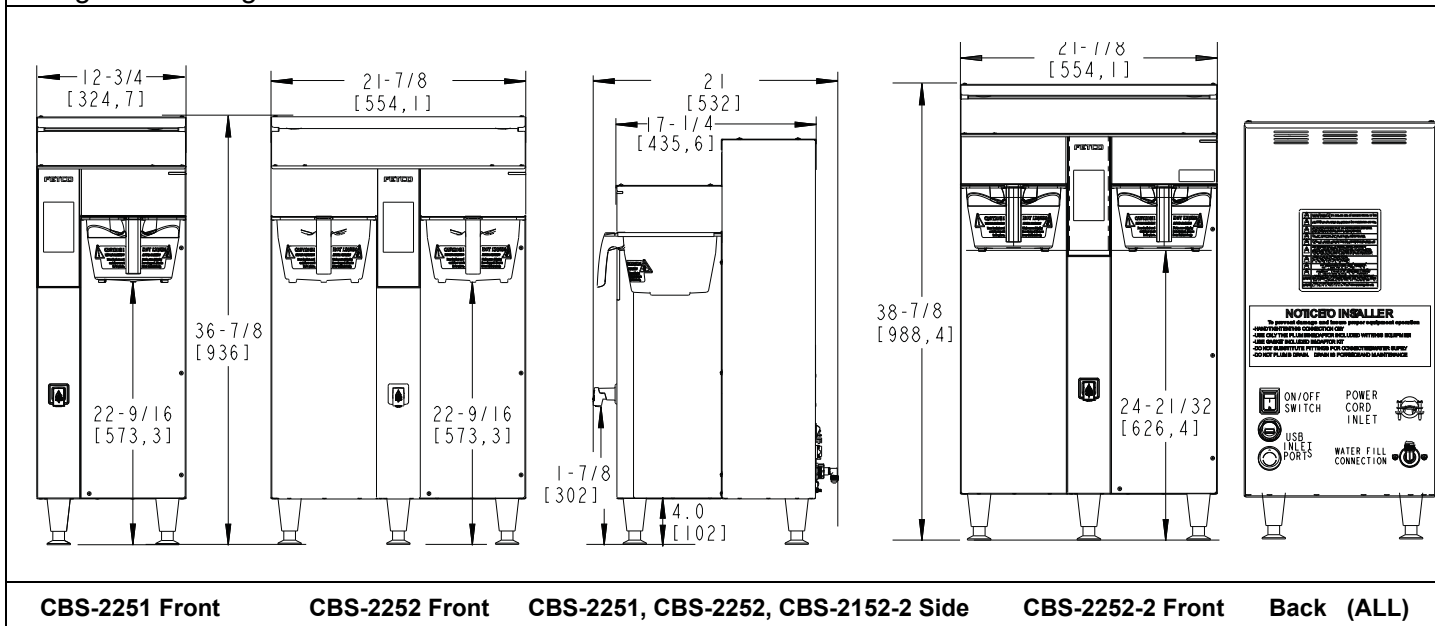

Electrical and Output Specifications for CBS-2251 <i>Next Generation</i> Single 1½ Gallon-6 Liter Coffee Brewers							
CBS-2251 Domestic USA and Canada models				Single-Voltage. With cUL/UL & NSF-4 Certification			
<b>Electrical and Output Specifications</b> All brewers use terminal block electrical connection for 50Hz or 60Hz Professional installation is required							
SKU Number	Phase	Voltage	Heater Configuration	Wires	KW	Maximum Amp Draw	Brew-Volume Per Hour
E2251US-1B230-PA110	1	200-240	2 X 3.0 kW	2+G	4.6-6.1	22.4-25.8	15.3 gal/58 liters
E2251US-1B230-MA110	1	200-240	2 X 3.0 kW	2+G	4.6-6.1	22.4-25.8	15.3 gal/58 liters
CBS-2251 Domestic and International models				Single-Voltage. With cUL/UL & NSF-4 Certification			
<b>Electrical and Output Specifications</b> All brewers use terminal block electrical connection for 50Hz or 60Hz Professional installation is required							
E2251IN-1B140-PA110	1	200-240	1 X 4.0 kW	2+G	4.1	14.2-17.1	9.3 gal/35 liters
E2251IN-1B150-PA110	1	200-240	1 X 5.0 kW	2+G	5.1	17.7-21.3	12.7 gal/48 liters
E2251IN-1B230-PA110	1	200-240	2 X 3.0 kW	2+G	6.1	21.3-25.5	15.3 gal/58 liters
CBS-2251 NOM (Mexico In Spanish) Single-Voltage. With cUL/UL & NSF-4 Certification							
<b>Electrical and Output Specifications</b> All brewers use terminal block electrical connection for 50Hz or 60Hz Professional installation is required							
E2251NM-1B230-PA110	1	200	2 X 3.0 kW	2+G	4.2	21.2	14.5 gal/54 liters
NM in SKU suffix (above) denotes equipment with NOM certification, Spanish labeling for Mexico and Spanish language user guide							
CBS-2251 Export CE		CE listed models with NSF-4 Certification. Internal EMI Filter				Not cUL or UL Listed	
<b>Electrical and Output Specifications</b> All brewers use terminal block electrical connection for 50Hz or 60Hz Professional installation is required							
E2251CE-2B230- PA110	2	2 X 2.3 kW	230/400	2L,N,PE	4.9	11.8	14.0 gal/53 liters
E2251CE-1B230-PA110	2	2 X 3.0 kW	230/400	2L,N,PE	5.6	12.4	15.3 gal/58 liters

Electrical and Output Specifications for CBS-2252 <i>Next Generation</i> Dual 1½ Gallon-6 Liter Coffee Brewers							
CBS-2252 Domestic USA and Canada				Field Selectable-Voltage. With cUL/UL & NSF-4 Certification			
<b>Electrical and Output Specifications</b> All brewers use terminal block electrical connection for 50Hz or 60Hz Professional installation is required.							
SKU Number	Phase	Voltage	Heater Configuration	Wires	KW	Maximum Amp Draw	Brew-Volume Per Hour
E2252US-UB230-MA110 Field Selectable 1 or 3 phase Sold as 3 phase	1	200-240	2 X 3.0 kW	2+G	4.6-6.1	22.4-25.8	15.3 gal/58 liters
	3	200-240	3 X 3.0 kW	3+G	6.9-9.1	19.5-22.5	22.5 gal/85 liters
E2252US-UB230-PA110 Field Selectable 1 or 3 phase Sold as 3 phase	1	200-240	2 X 3.0 kW	2+G	4.6-6.1	22.4-25.8	15.3 gal/58 liters
	3	200-240	3 X 3.0 kW	3+G	6.9-9.1	19.5-22.5	22.5 gal/85 liters
E2252US-UB250-PA110 Field Selectable 1 or 3 phase Sold as 3 phase	1	200-240	2 X 5.0 kW	2+G	7.6-10.1	36.9-42.5	25.3 gal/97 liters
	3	200-240	3 X 5.0 kW	3+G	11.4-15.1	32.0-36.9	38.3 gal/145 liters
CBS-2252 Domestic and International models				Single-Voltage. With cUL/UL & NSF-4 Certification			
<b>Electrical and Output Specifications</b> All brewers use terminal block electrical connection for 50Hz or 60Hz Professional installation is required.							
E2252IN-1B230-PA110	1	200-240	2 X 3.0 kW	2+G	4.6-6.1	22.4-25.8	15.3 gal/58 liters
E2252IN-1B250-PA110	1	200-240	2 X 5.0 kW	2+G	7.6-10.1	36.9-42.5	25.3 gal/97 liters
E2252IN-3B340-PA110	3	220/380 or 240/415	3 X 4.0 kW	4+G	12.2	15.7-17.1	29.5 gal/112 liters
E2252IN-3B330-PA110	3	220/380 or 240/415	3 X 3.0 kW	4+G	9.1	11.8-12.9	22.5 gal/85 liters
E2252IN-3B350-PA110	3	220/380 or 240/415	3 X 5.0 kW	4+G	15.1	19.5-21.4	38.3 gal/145 liters
CBS-2252 NOM (Mexico In Spanish) Field Selectable-Voltage. With cUL/UL & NSF-4 Certification							
<b>Electrical and Output Specifications</b> All brewers use terminal block electrical connection for 50Hz or 60Hz Professional installation is required							
E2252NM-UB250-PA110 Field Selectable 1 or 3 phase Sold as 3 phase	1	200-240	2 X 5.0 kW	2+G	7.6-10.1	36.9-42.5	25.3 gal/97 liters
	3	200-240	3 X 5.0 kW	3+G	11.4-15.1	32.0-36.9	38.3 gal/145 liters
E2252NM-1B250-PA110	1	200-240	2 X 5.0 kW	2+G	7.6-10.1	36.9-42.5	25.3 gal/97 liters
NM in SKU suffix (above) denotes equipment with NOM certification, Spanish labeling for Mexico and Spanish language user guide							
CBS-2252 Export CE		CE listed models with NSF-4 Certification. Internal EMI Filter				Not cUL or UL Listed	
<b>Electrical and Output Specifications</b> All brewers use terminal block electrical connection for 50Hz or 60Hz Professional installation is required							
E2252CE-3B350-PM110	3	230/400	3 X 5.0 kW	3L,N,PE	14.1	20.4	38.3 gal/145 liters
E2252CE-3B350-PA110	3	230/400	3 X 5.0 kW	3L,N,PE	14.1	20.4	38.3 gal/145 liters
E2252CE-3B330-PA110	3	230/400	3 X 3.0 kW	3L,N,PE	8.6	12.4	22.5 gal/85 liters



Electrical and Output Specifications for CBS-2253Next Generation Dual 2 Gallon-8 Liter Coffee Brewers							
CBS-2253 Domestic USA and Canada				Field Selectable-Voltage. With cUL/UL & NSF-4 Certification			
<b>Electrical and Output Specifications</b> All brewers use terminal block electrical connection for 50Hz or 60Hz Professional installation is required.							
SKU Number	Phase	Voltage	Heater Configuration	Wires	KW	Maximum Amp Draw	Brew-Volume Per Hour
E2253US-UB230-PA110 Field Selectable 1 or 3 phase Sold as 3 phase	1	200-240	2 X 3.0 kW	2+G	4.6-6.1	22.4-25.8	15.3 gal/58 liters
	3	200-240	3 X 3.0 kW	3+G	6.9-9.1	19.5-22.5	22.5 gal/85 liters
E2253US-UB250-PA110 Field Selectable 1 or 3 phase Sold as 3 phase	1	200-240	2 X 5.0 kW	2+G	7.6-10.1	36.9-42.5	25.3 gal/97 liters
	3	200-240	3 X 5.0 kW	3+G	11.4-15.1	32.0-36.9	38.3 gal/145 liters
CBS-2252 Domestic and International models				Single-Voltage. With cUL/UL & NSF-4 Certification			
<b>Electrical and Output Specifications</b> All brewers use terminal block electrical connection for 50Hz or 60Hz Professional installation is required.							
E2253IN-1B230-PA110	1	200-240	2 X 3.0 kW	2+G	4.6-6.1	22.4-25.8	15.3 gal/58 liters
E2253IN-1B250-PA110	1	200-240	2 X 5.0 kW	2+G	7.6-10.1	36.9-42.5	25.3 gal/97 liters
E2253IN-3B340-PA110	3	220/380 or 240/415	3 X 4.0 kW	4+G	12.2	15.7-17.1	29.5 gal/112 liters
E2253IN-3B330-PA110	3	220/380 or 240/415	3 X 3.0 kW	4+G	9.1	11.8-12.9	22.5 gal/85 liters
E2253IN-3B350-PA110	3	220/380 or 240/415	3 X 5.0 kW	4+G	15.1	19.5-21.4	38.3 gal/145 liters
CBS-2253 NOM (Mexico In Spanish)				Field Selectable-Voltage. With cUL/UL & NSF-4 Certification			
<b>Electrical and Output Specifications</b> All brewers use terminal block electrical connection for 50Hz or 60Hz Professional installation is required							
E2253NM-UB250-PA110 Field Selectable 1 or 3 phase Sold as 3 phase	1	200-240	2 X 5.0 kW	2+G	7.6-10.1	36.9-42.5	25.3 gal/97 liters
	3	200-240	3 X 5.0 kW	3+G	11.4-15.1	32.0-36.9	38.3 gal/145 liters
E2253NM-1B250-PA110	1	200-240	2 X 5.0 kW	2+G	7.0-10.0	35.2-42.2	26.6gal/100.7liters
NM in SKU suffix (above) denotes equipment with NOM certification, Spanish labeling for Mexico and Spanish language user guide							
CBS-2253 Export CE				CE listed models with NSF-4 Certification. Internal EMI Filter Not cUL or UL Listed			
<b>Electrical and Output Specifications</b> All brewers use terminal block electrical connection for 50Hz or 60Hz Professional installation is required							
E2253CE-3B350-PM110	3	230/400	3 X 5.0 kW	3L,N,PE	14.1	20.4	38.3 gal/145 liters
E2253CE-3B350-PA110	3	230/400	3 X 5.0 kW	3L,N,PE	14.1	20.4	38.3 gal/145 liters
E2253CE-3B330-PA110	3	230/400	3 X 3.0 kW	3L,N,PE	8.6	12.4	22.5 gal/85 liters

EXAMPLE: SKU E2253US-UB230-PM110														SKU NUMBER IDENTIFICATION KEY													
Product Line	Level		Family		Region ID		Phase	Voltage Range	# Heaters	Individual Heater Wattage		Brew Basket	Hot Water Faucet	Bypass	Brew Basket Locks		Power Cord										
E	2	2	5	3	U	S	U	B	2	5	0	P	M	01	1	0											
E=extractor					US =United States		1	A = 100-120	1	1.5		P=plastic	M=manual	1=Yes	1=Yes	0=Terminal Block											
			51= single side		IN = International		2	B = 200-240	2	1.7		M=metal	A=automatic	0=no	0=no	1= NEMA 5-15P											
		22=Next Gen Series	52= dual side		CE = CE		3	C = 380-415	3	2.3			N=None			2=NEMA 5-20P											
					NM = NOM		U = 1 or 3	D = 440-480		3.0						3=NEMA 6-15P											
										4.0						4=NEMA 6-30P											
			53= dual side 2 gallon					X=120 or 240 Dual Voltage		5.0						5= CEE 7/7 Schuko											
																6=UK1-13P											
																7= AUSTRALIAN											

Customer options	BREW BASKET TYPE (P, M OR C)	HOT WATER FAUCET (M, A OR N)	BYPASS (1 OR 0)	Brew Basket Lock (1 OR 0)
<b>* is factory standard feature</b> Add all the following numbers after all SKU numbers	<b>*P=Plastic</b> M=Gourmet Metal C= Gourmet Metal + clips	<b>*M=Standard manual</b> A=Automatic electronic N=No hot water faucet	<b>*1=With</b> 0=None	<b>*1=With</b> 0=None



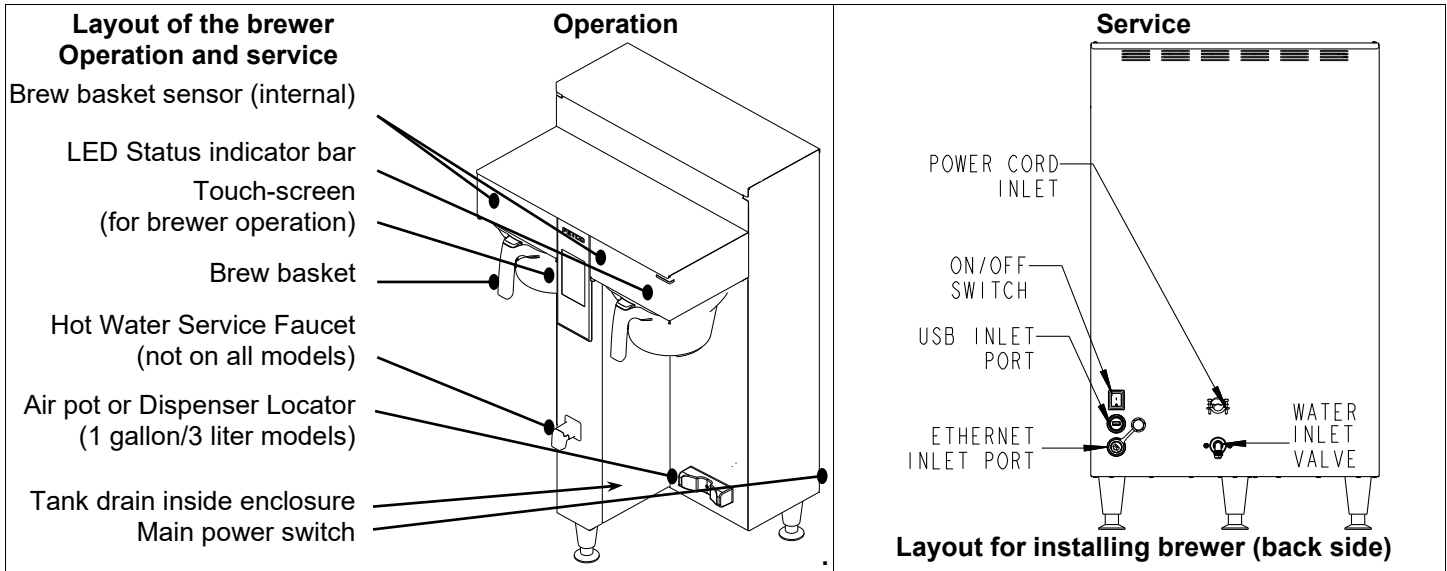

Fast start brewing goes here in TOC

Starting a brew-FETCO brewers are shipped fully programmed and calibrated		
	<ol style="list-style-type: none"> <li>1. Turn the power switch "ON". (Twin Shown)</li> <li>2. Prepare a brew basket with the correct size filter and appropriate amount of coffee. (6-12 ounces or 170-340 grams for 1½ gal/6 liters)</li> <li>3. Slide the brew basket completely into the rails.</li> <li>4. Place a clean, empty, preheated dispenser under the brew basket.</li> <li>5. Select a batch &amp; touch the corresponding BREW icon (Batch #1 selected in illustration), then press "START"</li> <li>6. -STOP icon will illuminate, -Countdown time will display, with proportional graphic circle icon -LED indicator will pulse. -All other BREW icons for that brew head will be hidden. ...-Opposite side BREW icons on dual brewer remain active</li> <li>7. When the brew cycle is finished, -Spray icon will extinguish, and the BREW circular icon will remain. This indicates that coffee may still be dripping from the brew basket For safety- do not remove brew basket until drip-out is complete.</li> </ol>	
Twin Brewer ready to brew. Batch one-top left brew position selected		Brewing in process Batch one selected

How to enter PROGRAMMING						
<p>To enter programming</p> <ol style="list-style-type: none"> <li>1. Turn the power switch "OFF", then "ON": Bootup will begin</li> </ol> <p>Tap the logo screen - after the bootup screen disappears (logo screen shown on right→)</p>		<ol style="list-style-type: none"> <li>2. "Enter Password" screen appears (shown right→)</li> </ol>		<ol style="list-style-type: none"> <li>3. Make changes and adjustments from the Programming Menu screen (Shown right→)</li> </ol> <p>See programming menu layout next page</p> <p>Enter the default factory master password. <b>9, 8, 7, 6</b></p> <p>Do not publish the master password. Use (1, 2, 3, 4) for general access password for all other operators.</p>		
	Logo screen			Password Screen		

# CBS-2200NG Next Generation Programming Menu Layout

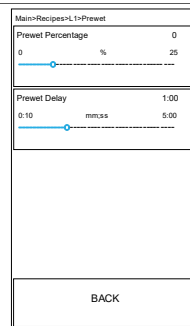
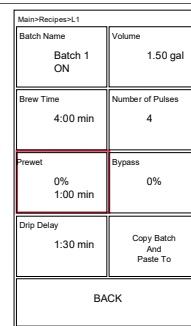
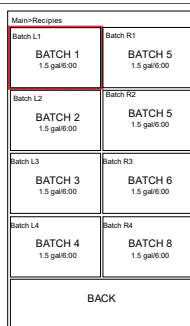
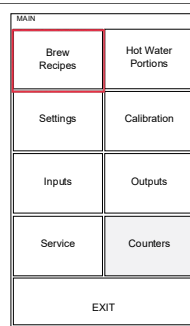
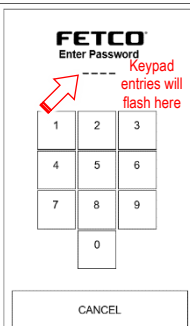
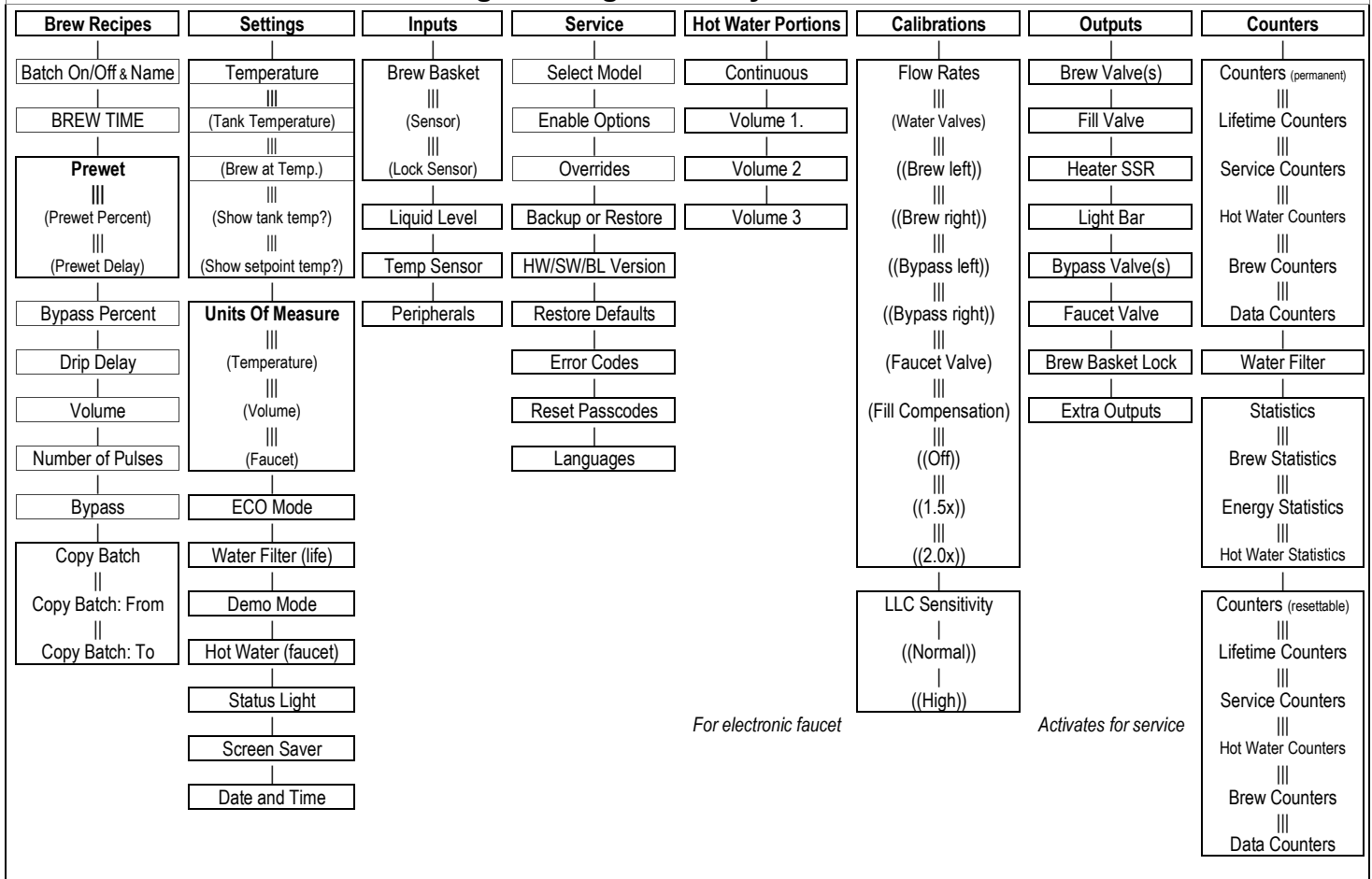

**TO ACCESS PROGRAMMING**  
Turn brewer OFF  
Then turn ON  
Waiting while bootup icons momentarily appear.

Tap the face panel when the legend screen appears

Enter the default factory master password.  
**9 . 8 . 7 . 6**  
Use (1, 2, 3, 4) for general access password for all other operators.

Touch Brew Recipes for setting the brewer parameters for each menu item  
Batch 1 will be selected



Touch Batch 1 to set the brew parameters.  
Prewet will be selected

Touch Prewet icon to adjust prewet  
The chart below describes the icons shown on this screen

Touch and slide to desired setting. Touch BACK when complete and make further adjustments or press BACK and SAVE & EXIT.

Brew Recipes	Program Items	Factory set Default	Programming Range	Notes
Batch Name	Batch On/Off	All "ON"	On/Off	Only top batch(s) are always enabled
Batch Name	Customize Name	Batch (1-4 L) (5-8 R)	Complete keypad	Scroll and tap three virtual keypads
Brew Time	Time of brew	4:00 minutes	2:00-12:00 mins/secs	Add to prewetting and drip delay times
Prewet	Prewet percentage	0	0-25% brew volume	Initial wetting to stabilize very fresh coffee
Prewet	Prewet delay time	1:00 sec.	0:10 sec to 5:00 min	Pause after coffee bed is prewitted
Drip Delay	Pause after brew	2:00 min:sec.	00.30 to 6:00	Time that brew basket remains locked during drip-out. This is a safety feature.
Brew Volume	Total volume	1.5 gallons/5.6 liters 1.0 gallon/3.8 liter 2.0 gallons/8liters	0.5-2.0 gal./0.95-8.0 liters	Factory set for 1½ gallon dispenser and for 1 gallon second batch
Number of Pulses	Start/stop in brew	8	4-20	Algorithm evenly divides brew time cycle
Bypass Percentage	Diverts brew water	0	0-40% of brew volume	Affects flavor, strength and mouth-feel
Copy & Paste Menu	Current recipe		Paste into all other recipes	Will paste selected into the other

MAIN	
Brew Recipes	Hot Water Portions
Settings 	Calibration
Inputs	Outputs
Service	Counters
EXIT	

Settings	Program Items	Factory set Default	Programming Range	Notes
Temperature	Tank Temperature	200°F/92°C	170-208°F/70-96°C	Hot water tank, brewing water temp.
Temperature	Brew at Temperature*	ON	OFF/ON	See note below
Temperature	Show Tank Temp.	ON	OFF/ON	Shows 1 <sup>st</sup> at top right screen
Temperature	Show Setpoint Temp.	ON	OFF/ON	Shows 2 <sup>nd</sup> at top right screen
Units of Measure	Temperature Volume Hot water Faucet	F° or C° degree units Gallon or Liters units Ounce or Milliliters	NO or YES	Main>Settings>UNITS Temperature  Volume  Faucet 
ECO Mode	ON/OFF Eco idle time (to start) Eco Tank temperature	OFF 1 hour 169°F	Turn on or off 1-6 hours 158°F to 176°F	Screen will display Eco Mode when activated-will take time to reheat to set brew water temperature
Water Filter	Water filter installed Rated filtering volume	NO 2625 gallons	NO or YES 250 gallons to 3950 gallons	
Demo Mode	Disables controls	OFF	OFF/ON	For training and user familiarization
Hot Water	Digital H. Wtr Faucet	ON	ON/OFF/Automatic	Automatic activates portion control
Status Light	READY LED color	Green	White/Blue/Green	Color when brewer is ready to brew
Screen Saver	Covers recipe screen	OFF	ON/OFF & Timeout setting	"OFF" leaves recipe screen
Date and Time	Set unit date and time	12 hour format	12/24 hour format & date	Store in real time clock

**NOTES: Brew at Temperature\***

Brew At Temp: "ON"  
 (Default: factory programmed into brewer)  
 "BREW START" will not be accessible until tank temperature is at set point.  
 "BREW START" becomes accessible when hot water tank is at the selected temperature.  
 Menu screen will be dimmed if tank temperature is low  
 Brew At Temp: "OFF" USER SELECTABLE (Not recommended)  
 Allows brewing at any temperature above 170°F/77°C.  
 May not apply for two sided brewer if one side is in brew cycle

**Altitude Correction Chart**

Chart to correct for altitude for boiling point in tank water temperature.

[ft]	[m]	Suggested Setting[°F]	Boiling point[°F]	Suggested Setting[°C]	Boiling point [°C]
0	0	205	212.0	96	100.0
500	152	205	211.0	96	99.5
1000	305	200	210.1	93	98.9
2000	610	200	208.1	93	97.8
2500	762	200	207.2	93	97.3
3000	914	200	206.2	93	96.8
3500	1067	197	205.3	92	96.3
4000	1219	195	204.3	91	95.7
4500	1372	194	203.4	90	95.2
5000	1524	194	202.4	90	94.7
5500	1676	193	201.5	89	94.2
6000	1829	192	200.6	89	93.6
6500	1981	191	199.6	88	93.1
7000	2134	190	198.7	87	92.6
7500	2286	188	197.8	86	92.1
8000	2438	187	196.9	86	91.6
8500	2591	185	196.0	85	91.1

**Brew At Temperature**

Ideal brew water temperature is 200°F/93°C. After brewing, brewers can take time to recover the hot water tank temperature and signal READY to brew. This is called "recovery time". The lag in recovery time is caused by rapid brewing cycles in a rush, low power heating elements, low incoming electrical voltage, water supply temperature, even the barometric pressure.

Operators will adjust the "Brew At" temperature to allow the brewing at lower temperatures. This will allow a *slightly* faster recovery time and give a small increase in brew cycles per hour.

Reduced brew temperature will always compromise the quality of the finished brew and lower the temperature of the customers coffee.

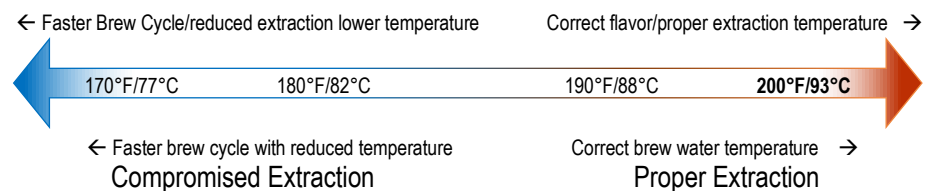

Inputs	Program Items	Factory set Default	Programming Range	Notes
Brew Basket	Sensor	Displays activity	Brew basket in place?	LEFT <input type="radio"/> RIGHT <input type="radio"/> (green=on;red=off)
Brew Basket	Lock Sensor	Displays activity	Brew basket locked?	LEFT <input type="radio"/> RIGHT <input type="radio"/> (green=on;red=off)
Liquid Level	LOW	Not used	Not used	Not used
Liquid Level	HIGH	Hot water tank fill	Filled/Not Filled & signal	Green=Filled/Red=Not Filled
Temp. Sensors	Sensor 1	Hot water tank temp.	Actual temperature & signal	
Temp. Sensors	Sensor 2	Not used	Not used	Not used
Peripherals	USB1	Digital input/output	Displays activity	(green=active;red=off)
Peripherals	USB2	Not used	Not used	Not used
Peripherals	RS-232	Digital input/output	Displays activity	(green=active;red=off)

Service	Program Items	Factory set Default	Programming Range	Notes
Select Model	Set brewer model	CBS-2242	MODEL (single side) 1 (dual side) 2 223x <input type="radio"/> 224x <input type="radio"/> 225x <input type="radio"/> 226x <input type="radio"/>	To select: touch icon for brewer, touch "BACK" and got to EXIT & SAVE
Enable Options			Options Electric HW faucet <input type="checkbox"/> OFF <input type="checkbox"/> ON Bypass Valve(s) <input type="checkbox"/> OFF <input type="checkbox"/> ON Brew Basket Lock(s) <input type="checkbox"/> OFF <input type="checkbox"/> ON Expansion Board <input type="checkbox"/> OFF <input type="checkbox"/> ON	
Overrides	Brew Basket Sensor Brew Basket Lock Brew Basket Lock Sensor HW Press and hold		Override Safety Features Left Right Brew Basket Sensor <input type="checkbox"/> OFF <input type="checkbox"/> OFF Brew Basket Lock <input type="checkbox"/> OFF <input type="checkbox"/> OFF Br. Basket Lock Sensor <input type="checkbox"/> OFF <input type="checkbox"/> OFF HW Press and hold <input type="checkbox"/> OFF <input type="checkbox"/> OFF	Overriding deactivates onboard safety systems. This is not recommended for normal operation. A warning/reminder will display in the start screen
Backup or Restore	Backup current configuration	Will save all programmed settings	Requires USB thumb drive	Insert USB thumb drive and touch "BACKUP" & follow instructions
Backup or Restore	Installs saved settings	USB thumb drive with one file-	One file, must be titled: backup.txt	Insert USB thumb drive and touch "RESTORE" & follow instructions
HW/SW/BL Version			Software UI 0.2.221011a IO 0.3.20221119a Bootloader UI Bootloader IO Compilation Time UI Oct 11 2022 13:28:09 IO Nov 29 2022 15:12:20 Hardware Main Board rev IO Board rev	
Restore Defaults	Return factory sets		Will overwrite all settings	Touch and hold icon 5 seconds
Error Codes			<u>Error Log</u> Error Code→ Code & definition Date/time stamp <u>Export Log To USB</u> Follow prompts to export <u>Error Statistics</u> Error code frequency <u>Error Statistics</u> Follow prompts to delete	
Reset Passcodes	Overrides default		<u>Operator Code</u> Follow prompts to change <u>Service Code</u> Follow prompts to change	
Languages	Reserved for future use			

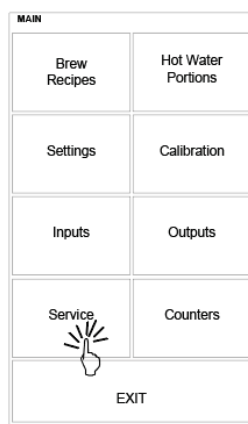
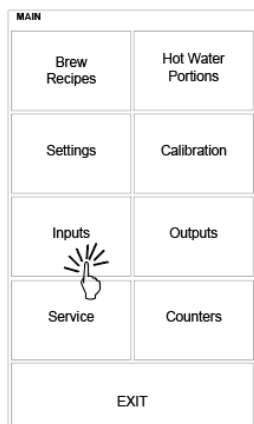

Error Codes (From SERVICE – Page 8)			
DO NOT CLEAR ERROR CODES UNTIL ERROR IS IDENTIFIED AND CORRECTED			
→Contact factory or specialized personnel for error codes			
Code	Description	Possible Cause	Corrective Action
001	Software error-error on start up or corrupted software	Improper start-up or shutdown	Restart, if still fault: reload software
002	Internal flash corrupted internal data memory malfunction	Error found in cyclic redundancy check <b>CRC</b>	Restart, if still fault: reload software If not corrected: replace board
010	Front U/I board loses communication with the interior O/I board	No communication between front panel	Cycle brewer Off then On. Check cable connections
011	Front U/I board bad communication with the interior O/I board	Disrupted communication Cable connections loose	Cycle brewer Off then On. Check cable connections
<p>Error codes 10 and 11 may be generated by loose connections, electronic interference, or a software/bootloader issue.</p> <p>For assistance by email: open the SERVICE menu and go to the <u>HW/SW/BL Version</u>. Send a cellphone picture of this screen to techsupport@fetco.com with the serial number of the equipment and your return phone number.</p> <p>For live service, write down the screen information or have the HW/SW/BL Version available and contact FETCO by phone at (800) 338-2699 option 2) to discuss with Technical Service. (Email support is usually faster)</p> <p>The correction for ERROR 10 or 11 may require a simple Off/On power cycle or a bootloader/firmware update that can be sent by email. Contact FETCO as above if cycling power or connections do not correct the fault.</p>			
050	Short-circuit in temperature probe	Probe failure.	Replace probe.
051	Open temperature probe.	Bad probe connection, or probe failure.	Check all connections. Replace probe if necessary.
100	Initial Fill Error. Initial fill time took longer than expected after powering up.	Water supply flow rate is too low, fill valve is stuck, water line kinked or closed.	Reboot machine. If persists-investigate cause of low flow rate. (Clogged water filter, kinked line, stuck fill valve)
101	Error on refill-. Tank did not refill within expected time.	Water supply flow rate to hot water tank is too low, or fill valve stuck or damaged <b>(SEE PAGE 14)</b>	Check water supply line. Flow should be 20-75 psig, (138-517kPa) >1gal/3.8L/min Investigate cause of low flow rate. If the flow rate is in range-replace fill valve
200	Heating flatline-Tank is boiling	Heater is on, temperature is not rising/dropping	High elevation correction. Bad heaters or temperature probe or position
201	If the hot water tank heaters are turned on during a heating cycle and tank temperature is not increasing according to software logic and the tank temperature is below setpoint	1) Failure of SSR, high limit, temperature probe, or heating element.  2) Water being removed by hot water faucet during heating (control displays "heating")	1)Test and check SSRs, high limit devices temperature probe. Check heating elements with current clamp, replace if necessary.  2)Advise staff to refrain from taking large amounts of water from hot water tank, especially during "heating".
202	Heater Shorted or Stuck SSR	Heater is off and heating SSR is stuck "ON"	Check ohms on heater (15-60Ω). SSR may be stuck in ON mode-replace SSR.
255	Keyboard [HID] error ( <u>H</u> uman <u>I</u> nterface <u>D</u> evice)	Usually from longer than 10 seconds' contact. Or faulty reassembly after service	Restart, if still fault: reload software. If mechanical: replace module
NO BSKT <b><u>Insert Brew Basket</u></b>		Brew basket must be in place <b>This is a SAFETY FEATURE</b>	Insert brew basket into brewer rails to enable brewer

Hot Water Portions	Program Items	Factory set Default	Programming Range	Notes
This setting is only for brewers with an electronic hot water faucet. In the <u>SETTINGS</u> menu, the "Automatic" feature must be enabled				
Hot Water Portions	Enabled	"ON"		OFF/ON
Hot Water Portions	Name	Continuous	Rename on keypad	Scroll and tap three virtual keypads
	Safety Timeout	0:25	0:10 min 0:60 -----○----- Scroll and go to EXIT&SAVE	Sets limit for touch and dispense
Hot Water Portions	<b>Volume 1</b>	6 oz.		
	Enabled	ON	Turns "ON" or "OFF"	OFF/ON
	Name	Volume 1	Rename on keypad	Scroll and tap three virtual keypads
	Volume dispensed	6 oz	Volume 6 2 oz 30 -----○----- Scroll and go to EXIT&SAVE	Sets limit for #1 touch and dispense
Hot Water Portions	<b>Volume 2</b>	8 oz		
	Enabled	ON	Turns "ON" or "OFF"	OFF/ON
	Name	Volume 2	Rename on keypad	Scroll and tap three virtual keypads
	Volume dispensed	8 oz	Volume 8 2 oz 30 -----○----- Scroll and go to EXIT&SAVE	Sets limit for #2 touch and dispense
Hot Water Portions	<b>Volume 3</b>	8 oz		
	Enabled	ON	Turns "ON" or "OFF"	OFF/ON
	Name	Volume 3	Rename on keypad	Scroll and tap three virtual keypads
	Volume dispensed	12 oz	Volume 12 2 oz 30 -----○----- Scroll and go to EXIT&SAVE	Sets limit for #3 touch and dispense

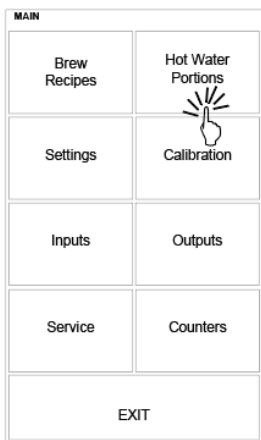

Calibration	Program Items	Factory set Default	Programming Range	Notes
Flow Rates Water Valves	Brew left	3000 ml/min	Brew Left 0.95(Gal.)/3550 (ml) 3000 ml/min 4150 0.79 gal/min 1.09 -----○-----	Use to attenuate and compensate for variations in brew valve output
Flow Rates Water Valves	Brew right	3000 ml/min	Brew Right 0.95(Gal.)/3550 (ml) 3000 ml/min 4150 0.79 gal/min 1.09 -----○-----	Use to attenuate and compensate for variations in brew valve output
Flow Rates Water Valves	Bypass left	1900 ml/min	Bypass Left 0.38(Gal.)/1400 (ml) 1150 ml/min 1700 0.30 gal/min 0.44 -----○-----	Use to attenuate and compensate for variations in bypass valve output
Flow Rates Water Valves	Bypass right	1900 ml/min	Bypass Right 0.38(Gal.)/1400 (ml) 1150 ml/min 1700 0.30 gal/min 0.44 -----○-----	Use to attenuate and compensate for variations in bypass valve output
Flow Rates Faucet Valve	For automatic hot water faucet	4 ml/min	Faucet 1500 500 ml/min 5000 -----○----- Scroll and go to EXIT&SAVE	To compensate variations in timed dispense from automatic hot water faucet
Fill Compensation	Slow Flow Compensation	OFF	○ Off ○ .. 1.5x ○ 2.5x Scroll and go to EXIT&SAVE	Use for FloJet bottled water supply or for reduced water supply from mains.
LLC		NORMAL	○ Normal ○ .. High Scroll and go to EXIT&SAVE	Liquid level control sensitivity. Normal for most water. High is for reverse osmosis water or very pure water.

### How to calibrate the flow rate for FETCO brewers

Set the flow rates of the brewer valves to adjust for over or under potting.

Built-in algorithms in brewer controller software corrects brew parameter to customer preferences or to trim variations in flow control components  
The control software uses the new flow rate entered in the CALIBRATION screen to adjust and correct the amount of water delivered by the valve

Increasing the flow rate value **DECREASES** the volume of water dispensed

Decreasing the flow rate value **INCREASES** the volume of water dispensed

Flow rate adjustment will control all batches made by the valve. All batches on the side of the valve will be adjusted, (left or right)

-Obtain the **VOLUME DISPENSED** of water only, by brewing a batch without coffee or filter paper.

-Obtain the **PROGRAMMED VALUE** of the same brew. This is displayed on the home screen in the batch box

-Obtain the **CURRENT SETTING** for the flow rate from the brewer. Do this by entering PROGRAMMING and Tap to "CALIBRATION" then, tap "Flow Rates" and then "Water Valves". The valves flow rate is in the top right corner.

Using the values obtained above to obtain the new flow rate setting to correct the volume dispensed:

Divide the volume dispensed by the programmed volume and then multiply by the current setting

$$\frac{\text{VOLUME DISPENSED}}{\text{PROGRAMMED VALUE}} \times \text{CURRENT SETTING} = \text{NEW FLOW RATE SETTING}$$

-Enter programming mode, tap to "CALIBRATION"

-Tap back to "Flow Rates" and then to "Water Valves"

-Enter the new flow rate into the calibration slider for the valve tested

Note: values for brewers set in gallons are in decimal format. Place all quantities in ounces and divide by 128 (One gallon =128 ounces)  
to obtain decimal format → 1 ½ gallon=128oz+64oz=192 oz (in 1 ½ gal.) 192÷128=1.5 gal.

Example below shows overpotting of 16oz over 11/2 gal. batch corrected by recalibration using the formula above

Obtain Volume Dispensed	Obtain Programmed Value	Obtain Current Setting	Use the formula above	Enter the New Flow Rate
Example: A CBS-2252 delivered 16 ounces over the 1½ gallon (192oz) setting for Batch 1-Left Side 192oz+16oz=208oz	The Programmed value for batch 1 -left side of the CBS-2252 is on the home screen in the batch box.	The valves flow rate is in the top right corner Brew Left 0.93(Gal.) 0.79 gal/min 1.09 -----○----- The value is 0.93	$\frac{1.65}{1.5} \times 0.93 = 1.02$ The new flow rate is 1.02	Brew Left 1.02(Gal.) 0.79 gal/min 1.09 -----○----- Enter new setting on the slider as shown and EXIT to save. Retesting recommended
208oz÷128oz/gallon=1.63gallon	The value is 1.5 gallon			

**By entering the new flow rate number into the brewer, the software automatically corrects the volume discrepancy**



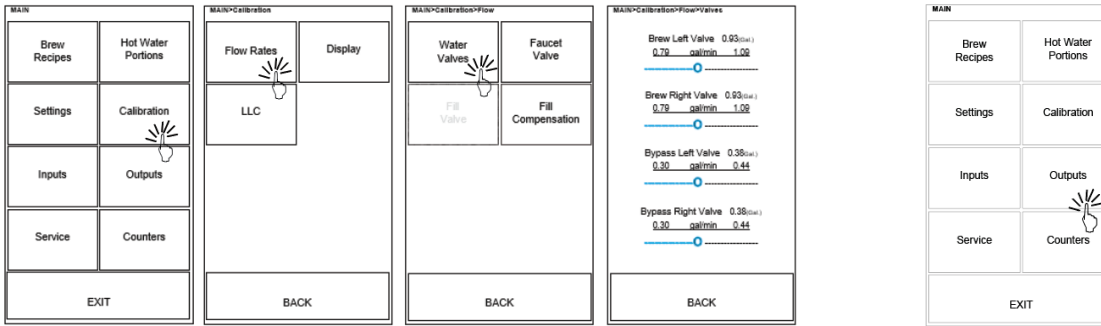

PROGRAMMING sequence for calibrating left brew valve from page 10

Enter into OUTPUTS-below

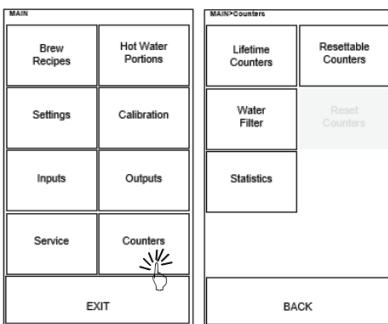

Outputs	Program Items	Factory set Default	Programming Range	Notes
These settings are used to activate individual controls for testing verifications and servicing operations				
Brew Valve(s)	Momentarily operate Left or Right Brew valves		Brew Left  Right	Have dispenser under spray head! Touch to activate flow
Fill Valve	Momentarily operate fill valve		Fill	Have dispenser under spray heads! Touch to activate flow
Heater SSR	Turns on all heaters		Heater 3 sec max	Activates SSRs to turn on heaters
Light Bar	Momentarily operate light bar(s)		Status Light	
Bypass Valve(s)	Momentarily operates Left or Right Bypass valves		Bypass Left  Right	Have dispenser under bypass port! Touch to activate flow
Faucet Valve	Momentarily operate faucet valve	For brewers with automatic hot water faucet	Faucet	Have dispenser under faucet! Touch to activate flow
Brew Basket Lock	Operates brew basket locks, toggling them on and off		BBL lock Left  Right  BBL Unlock Left  Right  BBL Sensor Left  Right	Will toggle brew basket locks to be engaged then OFF.
Extra Outputs	For future use	Not used	Not used	Not used



Counters	Program Items	Factory set Default	Programming Range	Notes
This setting shows usage of the brewers functions				
Lifetime Counters	Service Counters		Main>Counters>Lifetime>Service <b>Lifetime Counters</b> (units in hours and liters) Unit Uptime 0 Fill Valve Volume 0 Activation 0 Heater Time On 0 Activation 0 Hot Water Dispense Count 0 Hot Water Valve Volume 0 Activation 0 Brewer Volume 0 <b>Left</b> <b>Right</b> Brew Count 0 0 Brew Valve Volume 0 0 Activation 0 0 Bypass Valve Volume 0 0 Activation 0 0 Locks Activation 0 0	
	Hot Water Counters		Main>Counters>Lifetime>Faucet <b>Lifetime Counters</b> (units in liters) <b>Volume</b> <b>Activation</b> Continues 0 0 1 0 0 2 0 0 3 0 0	
	Brew Counters		Main>Counters>Lifetime>Brew <b>Lifetime Counters</b> (units in liters) <b>Recipe Number</b> <b>Activation</b> <b>Volume</b> 1 0 0 2 0 0 3 0 0 4 0 0 5 0 0 6 0 0 7 0 0 8 0 0	
	Data Counters	Reserved for future		
Water Filter	Water Filer Life Time		Main>Counters>Reset Filter <b>Water Filter Life Time</b> Filter Life Time 0% of 10,000  Press and hold button for 5 seconds To Reset Filter  	
Statistics	Brew Statistics	Reserved for future		
	Energy Statistics	Reserved for future		
	Hot Water Statistics	Reserved for future		
Resettable Counters	Service Counters	See screen above	Main>Counters>Reset>Clear	Clear Resettable Counters  Press and hold button for 5 seconds To Clear Error Log  
	Hot Water Counters	See screen above		
	Brew Counters	See screen above		
	Service Counters	See screen above		



## Brewer Setup

NOTE-Assemble legs immediately after unpacking the brewer and before connection to utilities

### 1) Attach legs

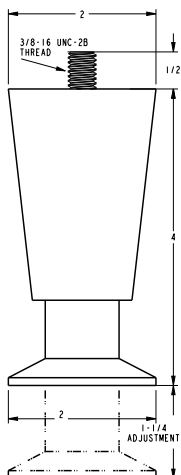

**NOTE**-Legs are shipped with the brewer for install  
The legs are shipped in the brew basket.

#### 4" legs -

Part number 1073.00007.00  
3 required for CBS-2252  
4 required for CBS-2251

Legs are sent from factory inside brew basket. Always attach legs before installing

### 2) Attach water inlet adapter

Place rubber washer with screen in adapter. Hand tighten only-and 1/4 turn with wrench

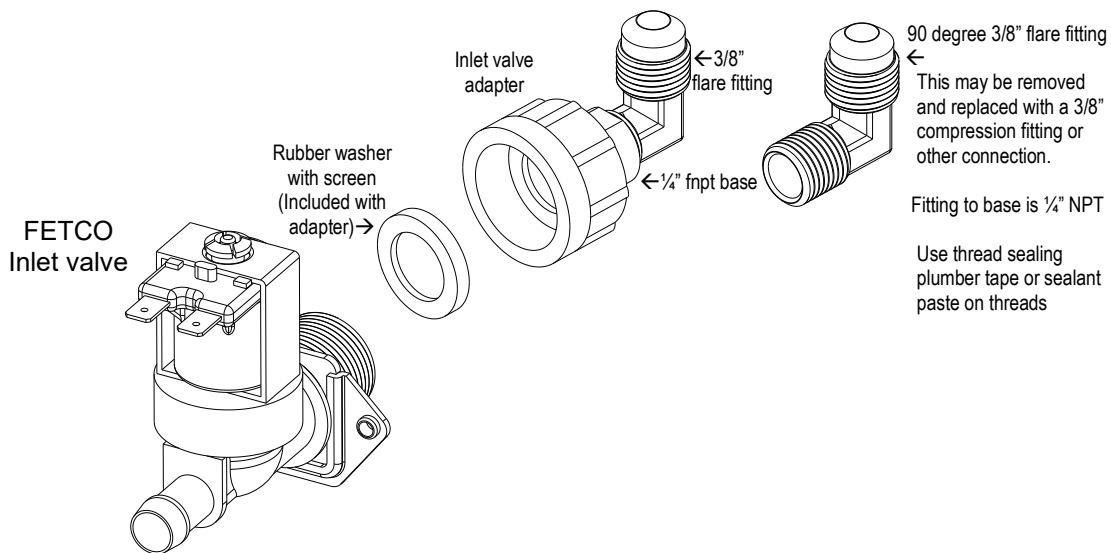

Install the adapter on inlet valve first before attaching water line. Adapter is shipped in the brew basket  
The valve threads are 3/4" BSP MALE THREAD and are not 3/4" garden hose fittings.  
Use of any other connector to valve will damage the valve  
DO NOT use US dishwasher water adapter or US washing machine adapter for this connection.  
The threads on these USA type adapters are unusable for the valve and will damage the valve  
The damaged valve will leak or will malfunction when damaged causing 100 or 101 error codes. (See page 9)

#### TO PREVENT DAMAGE AND INSURE PROPER EQUIPMENT OPERATION

The inlet valve thread is 3/4 INCH BSP (British Standard Pipe).

This valve is not a standard USA washing machine or dishwasher thread (3/4" GHT)

-Use only the plumbing adaptor kit included with this equipment. Use the gasket included in adaptor kit

-Plumber's tape is not recommended for the adapter to valve connection

-Hand tighten adapter on valve with gasket, then very lightly wrench 1/4 turn to set

-DO NOT SUBSTITUTE FITTINGS FOR CONNECTING TO WATER SUPPLY

Damage to inlet valve from improper installation will void the warranty

NOTE: DO NOT TANK PLUMB DRAIN. DRAIN IS FOR SERVICE AND MAINTENANCE.

# Installation Guide

(For Qualified Service Technicians Only)

## General:

1. If not installed correctly by qualified personnel, the brewer will not operate properly and damage may result.
2. Utilize only qualified beverage equipment service technicians for service and installation.
3. Always have an empty dispenser under spray head of all coffee brewing equipment-including when at idle
4. Damages resulting from improper installation are not covered by the warranty, and will void the warranty.

## Electrical:

1. All FETCO brewers require **an electrical ground wire**. Installation without grounding is dangerous.
2. Note Equipotentiality Terminal, if present, (To identify the terminals which, when connected together, bring the various parts of equipment or of a system to the same potential, not necessarily being the earth (ground) potential, e.g. for local bonding.)
3. Verify voltages, polarity, circuits, and circuit breaker access before attaching equipment.
4. Brewers in this series wire differently in regards to a neutral wire. Review the wire diagrams.
5. The electrical diagram is located in the User's Guide and online at [www.fetco.com](http://www.fetco.com).
6. Make sure of the tight grounding of the equipment and use the external ground bolt.
7. The installation must comply with applicable federal, state, and local codes having jurisdiction at your location. Check with your local inspectors to determine what codes will apply.

→See wiring diagrams for connections

## Plumbing:

1. North America: All installations must comply with applicable federal, state, or local plumbing codes.
2. All Others: The water and waste piping and connections shall comply with the International Plumbing Code 2003, International Code Council (ICC), or to the Uniform Plumbing Code 2003 (IAPMO).
3. Use an inline water filter for all beverage equipment.
4. Install the filter unit after a water shutoff valve and in a position to facilitate filter replacement.
5. The water line and newly installed filter cartage must be flushed thoroughly prior to connecting it to the brewer to prevent debris from contaminating the machine.
6. Verify that the water line will provide a flow rate of at least 1½gpm/(5.7lpm) per minute and the water pressure is between 20-75 psig (138-517kPa) before making any connections.
7. Use a wrench on the factory fitting when connecting the incoming water line. This will reduce stress on the internal connections and reduce the possibility of leaks developing after the install has been completed
8. Install a backflow prevention device. Most municipalities require a recognized backflow preventer. Usable on all hot beverage and cold beverage equipment is a WATTS® SD-2 or SD-3.



WATTS spring loaded double check valve models are accepted by most zoning authorities.

→The check valve should be as close to the water supply inlet of the beverage equipment as possible.

## Tank Drain

The water tank must be drained before maintenance procedures, and when the unit is to be relocated or shipped

1. Disconnect power and water to unit. DANGER: Insure that all utility connections to the brewer are broken.
2. Move the unit near a sink or obtain a container large enough to hold four gallons of water.  
→Note: the hot water tank may hold more than six gallons.
3. Remove the front panel and tank cover and allow the tank to cool to a safe temperature
4. The tank drain line and clamp are located inside-under the hot water tank. Pinch the drain line clamp to close
5. Locate the fill valve against the back wall, using pliers, loosen the hose clamp and move it back over the tube.  
→Note Do not loosen the hose clamp to the bottom of the hot water tank
6. Crimp the tube an inch or two away from the drain plug to prevent water from flowing and pull it off the valve.
7. Pull the tube end out of the brewer and position over sink or bucket.
8. Release the crimped tube and hose clamp and allow the water to flow into the sink or container.
9. Multiple buckets may be needed during the draining, see tank volumes below.

Brewer	Hot Water Tank Capacity	OPEN Leave open for use	
CBS-2251 Single	6.3 gal 24 liter	PINCH SHUT To drain tank & service brewer	
CBS-2252 Twin	11.5 gal 44 liter		

## Operator Training

Review the operating procedures with whoever will be using the brewer.

### Pay particular attention to the following areas:

1. Always pre-heat the dispensers before the first use of each day by filling them half way with hot water, and letting them stand for at least 5 minutes.
2. Do not remove the brew basket from a coffee brewer until it has stopped dripping.
3. Make sure the dispenser is empty before brewing into it.
4. Show how to attach covers, close, and or secure the dispensers for transporting.
5. Show the location and operation of the water shut off valve as well as the circuit breaker for the brewer.
6. Steam from the tank will form condensation in the vent tubes. This condensation will drip into and then out of the brew baskets. Up to 1/4 cup/60 cc discharging overnight is possible. Place an appropriate container under each brew basket when not in use.
7. We recommend leaving the power to the brewer on overnight. The water tank is well insulated and very little electricity is used to keep the tank hot. Leaving the brewer in the "ON" position will also avoid delays at the beginning of shifts for the brewer to reach operating temperature.

## Cleaning & Maintenance

### After Each Brew:

1. Dispose of grounds and rinse brew basket.
2. Never strike a brew basket or hit it against a hard surface.  
This will damage the brew cone, and may damage the brew basket support rails
3. Rinse dispensers before reuse.

### Every Day:

1. Wash brew basket with hot sudsy water.
2. Pull CSD from the spray head, it is magnetically attached. Use gloves or a heavy towel. → Wash off any film and reattach. Use vinegar if limescale filming is present.
3. Clean dispensers with hot suds water and a brush, rinse and air dry.
4. Use only a soft cloth and hot suds on the outside to avoid scratches. Never use abrasives that will scratch surface.

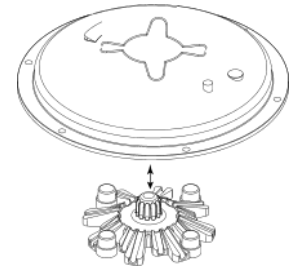

### Weekly

1. Use a commercial coffee dispenser cleaner such as URNEX™, TABZ™, DIP-IT™ or Squeak 'n Clean™.
2. Carefully Follow the instructions supplied with the cleaning product
3. Never use spray cleaners, solvent, solvent based cleaner or petroleum based polish anywhere on dispensers

## Warning

1. Turn off power before any cleaning procedure, including wiping the exterior for appearance reasons.
2. Dry the exterior, especially the face panel, before turning on power.
3. Do not apply any type of spray cleaner on the face panel of this equipment.
4. Never use solvent or solvent-based cleaner or petroleum based polish anywhere on this equipment.
5. Dry the face of the touch pad before turning on power
6. Do not electrically energize this equipment or attempt operation without all covers in place and all screws fastened.
7. Unplug machine before disassembly or servicing.

## Installation safety and hygiene directions-For International and CE equipment

1. Access to the service area is restricted to persons having safety/hygiene knowledge and practical experience of the coffee brewer. This appliance must be installed in locations where it can be overseen by trained personnel.
2. For proper operation, this appliance must be installed indoors where the temperature is between 10°C/50°F to 35°C/95°F. Drain and remove all liquid from equipment and lines if exposed to freezing temperatures.
3. All commercial cooking equipment, including this unit, is not intended for use by children or persons with reduced physical, sensory, or mental capabilities. Ensure proper supervision of children and keep them away from the unit.
4. Children should be supervised to ensure that they do not play hot beverage equipment.
5. This unit must be installed and serviced by qualified personnel only.
6. Installation must conform to all local electrical and plumbing codes. Installation by unqualified personnel will void the unit warranty and may lead to electric shock or burn, as well as damage to unit and/or its surroundings.
7. If the power cord requires repair or replacement-it must be performed by the manufacturer or authorized service personnel with the specified cord only from the manufacturer in order to avoid a hazard.
8. Review the dimensions for the unit and verify that it will fit properly in the space intended for it. Verify that the counter or table will support the total weight of the brewer and dispensers when filled (See: Technical Data).
9. Place the brewer on the counter or stand. When the brewer is in position, level it front to back as well as side-to-side by adjusting the legs.
10. Brewers will need a sturdy supported surface for operation. Do not move brewers when filled.
11. Do not tilt appliance more than 10° to insure safe operation.
12. Unit is for protected indoor use only. Do not steam clean or use excessive water on unit.
13. This unit is not "jet-proof" construction. Do not pressure wash or use jet spray to clean this unit.
14. The unit is not waterproof-do not submerge or saturate with water.

**Equipment exposed to flood and contaminated must not be used due to electrical and food safety.  
Do not operate if unit has been submerged or saturated with water.**

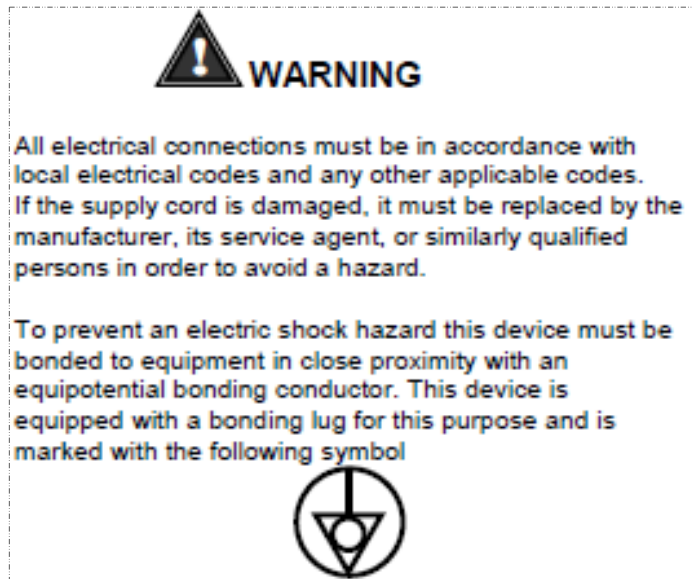

Labels and warnings for hot beverage equipment

	<b>WARNING</b> To reduce risk of electric shock or fire.
	FETCO® Hot Beverage Equipment is for commercial use only.
	Do not remove or open cover. No user serviceable parts inside. Refer installation and service to qualified personnel.
	Caution, disconnect from power supply before servicing.
	GROUND: National Electrical Code requires separate grounding wire.
	Use dedicated circuit with capacity rated by local code or National Electrical Code for the current draw of this equipment. Check serial number plate on right side for power requirements.
	Locate unit away from source of heat. Do not install or use near combustibles.
	<b>THIS APPLIANCE IS ENERGIZED WHENEVER IT IS CONNECTED TO A POWER SOURCE</b>
	<b>FAILURE TO COMPLY RISKS EQUIPMENT DAMAGE, PROPERTY DAMAGE, FIRE, OR SHOCK HAZARD</b>
	This equipment must be installed with a backflow protection device to comply with federal, state or local municipality codes.
	Read the user guide before installing and operating this unit.

Label for BACK PANEL of equipment (1046.00035.00)

Parts diagrams CBS-2252

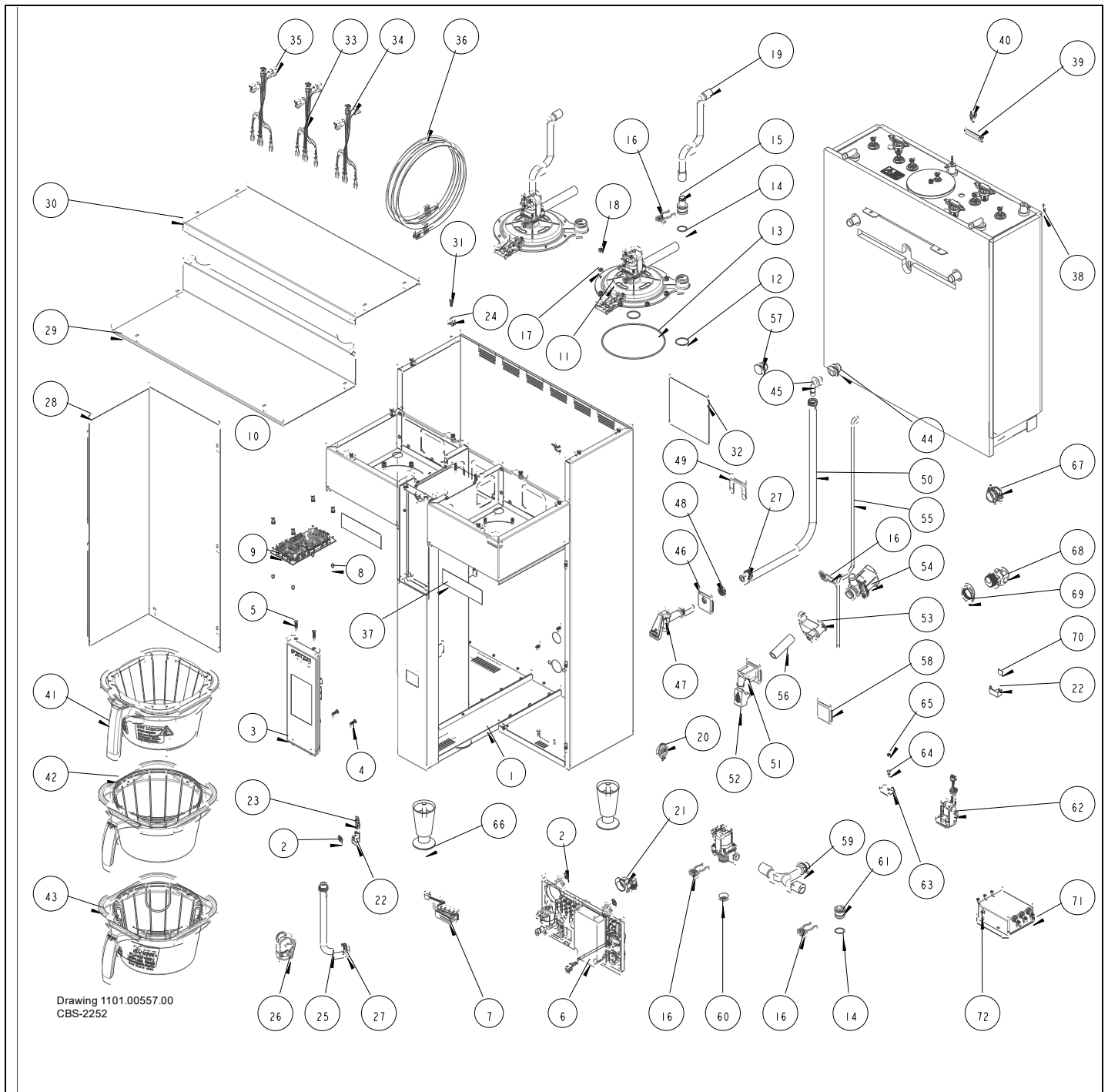

Drawing 1101.00557.00  
CBS-2252

Ref	Qty	Part Number	Description	Drawing 1101.00557.00 CBS-2252
1	1	1111.00099.00	WELDMENT BODY, CBS-2252	
2	6	1084.00051.00	NUT, HEX LOCKWASHER, #8-32, 18-8 ST. STL.	
3	1	1102.00448.00	FRONT PANEL ASSEMBLY, CBS-2200 SERIES	
4	2	1082.00020.00	SCREW, #6 X 5/8, TRUSS HD PHIL, SHEET MTL	
5	2	1082.00058.00	SCREW, # 8-32 X 5/8, FLAT HD, PH, 18-8 SS	
6	1	1102.00449.00	ELECTRICAL COMPONENT LATTICE, CBS-2200	<b>Please see page 26 for full parts list</b>
7	1	1102.00444.00	VISUAL COMMUNICATION RGB LED BAR, ASSY	
8	4	1081.00006.00	SPACER, 6MM OD x 3.2MM ID x 5MM LG, Z/P	
9	1	1051.00046.00	CBS-2200 SERIES, I/O BOARD, 24V	
10	4	1029.00006.00	NUT, FINGER KNURLED, #4-40	
11	2	1102.00450.00	QUICK CONNECT SPRAYHEAD ASSEMBLY, BASIC	<b>Please see page 27 for full parts list</b>
12	4	1024.00107.00	O-RING, 1 3/16" OD X 1 1/16" ID X 1/16" TH, BYPASS SEAL	
Parts list continues next page				



Ref	Qty	Part Number	Description	Drawing 1101.00557.00 CBS-2252 ...Continued from page 13
13	2	1024.00108.00	O-RING, 5 11/16"OD X 5 1/2" ID X 3/32" TH, BREW SEAL	
14	3	1024.00106.00	O-RING, 13/16"OD X 11/16"ID X 1/16" TH, FOR QUICK CONNECT	
15	2	1023.00343.00	VENT INSERT, QUICK CONNECT	
16	5	1023.00342.00	QUICK CONNECT CLIP	
17	16	1083.00010.00	WASHER, #10 SCREW W/NEOPRENE-BONDED SEAL	
18	16	1084.00006.00	NUT, 8-32 18-8 HEX MACHINE SCREW	
19	2	1024.00098.00	VENT TUBE, CBS-XTS/XV+ EXTRACTOR SERIES	
20	2	1086.00004.00	BUSHING, SNAP, 1" MOUNTING HOLE	
21	1	1102.00243.00	ADAPTER ASSY, 3/4" BSP x 1/4" NPT x 3/8" TUBE	
22	12	1065.00009.00	GROUND LUG CONNECTOR, 14-2 AWG, ALUMINUM	
23	1	1044.00012.00	LABEL GROUND, CE	
24	12	1084.00011.00	NUT, CLIP ON (J-NUT), #6-32, 22-20 GA., BLK-PH FINISH	
25	1	1025.00058.00	TUBE, 9/16"OD X 5/16"ID X 25.00"LG	
26	1	1086.00009.00	CLAMP, 3/4" MAX TUBE OD FLOW CONTROL	
27	4	1086.00003.00	UNICLAMP, 15.9 HOSE OD CLAMP	
28	1	1112.00529.00	WELDMENT FRONT COVER, CBS-2250	
29	1	1001.00352.00	COVER, UPPER BASE, CBS-1152 EXTRACTOR V+	
30	1	1001.00399.00	COVER TOP, CBS-2252	
31	12	1082.00017.00	SCREW, TRUSS HD. PHIL. MACHINE, # 6-32 X 1/2 LG.	
32	1	1046.00035.00	LABEL, WARNING "TO REDUCE RISK OF ELECTRIC SHOCK OR FIRE"	
33	1	1402.00106.00	HARNESS, CBS-2240/50-NG, LOW AMP, UNIVERSAL	
34	1	1402.00107.00	HARNESS ADDITION, CBS-2242/52-NG, LOW AMP, UNIVERSAL	
35	1	1402.00053.01	HARNESS HIGH AMP, CBS-1152-XV+	
36	1	1063.00042.00	ETHERNET CABLE, CAT-7, 5FT LENGTH	
37	2	1046.00003.00	LABEL, CSD WARNING, 1.5" X 5.0"	
38	1	1104.00160.00	COMPLETE TANK ASSEMBLY, CBS-2252, 3 X 3KW/240VAC	
38	1	1104.00161.00	COMPLETE TANK ASSEMBLY, CBS-2252, 2 X 3KW/240VAC	
38	1	1104.00162.00	COMPLETE TANK ASSEMBLY, CBS-2252, 3 X 4KW/240VAC	
38	1	1104.00163.00	COMPLETE TANK ASSEMBLY, CBS-2252, 3 X 5KW/240VAC	
38	1	1104.00164.00	COMPLETE TANK ASSEMBLY, CBS-2252, 2 X 5KW/240VAC	
39	1	1022.00032.00	SLEEVE, Ø.50 x 2.0" LG. x 1.50" SLOT	
40	2	1066.00003.00	CABLE TIE, 3-7/8" LG., BLACK	
41	1	B015280BN2	BB ASSEMBLY, 16" x 6", Ø.280" HOLE <b>Please see page 28 for full parts list</b>	
42	1	B001280B1BB	ASSY, 16" X 6", 0.280 DIA HOLE, BLACK	
43	1	B002280B1BB	ASSY, 16" X 6", 0.280" DIA HOLE, BLACK	
44	1	1024.00050.00	GROMMET, SILICONE, 11.4mm ID	
45	1	1023.00183.00	FITTING, ELBOW, GROMMET, .375"	
46	1	1023.00348.00	HOT WATER INSERT, MANUAL FAUCET	
47	1	1071.00055.00	FAUCET, HOT WATER, PSC-BR-8, WITH FLAT AND STEM	
48	1	1084.00048.00	JAM NUT, 1/2-20 UNF, NICKEL PLATED BRASS	
49	1	1003.00370.00	HOT WATER INSERT LOCK	
50	1	1025.00082.00	TUBE, 5/8"OD X 3/8"ID X 19.00"LG.	
51	1	1023.00346.00	HOT WATER INSERT, AUTO FAUCET	
52	1	1029.00041.00	COVER, AUTO HOT WATER FAUCET, SILICONE	
53	1	1023.00347.00	VALVE MOUNT, HOT WATER DISPENSER	
54	2	1057.00076.00	VALVE ASSEMBLY, COMPLETE, NG, DELTROL	
55	1	1025.00026.00	TUBE, 1/4"OD X 1/8"ID X 25"LG, VENT, HOT WATER VAPOR	
56	1	1025.00138.00	TUBE, SILICONE, 3/4" OD X 1/2" ID X 2.5" LG, HOT WATER	
57	1	1024.00051.00	GROMMET, SILICONE, BLANK	
58	1	1023.00349.00	HOT WATER INSERT, NO FAUCET	
59	1	1029.00040.00	BYPASS T-TUBE, SILICONE, 2200 DUAL SERIES	
60	1	1023.00345.00	ORIFICE INSERT, QUICK CONNECT	
61	1	1023.00344.00	PLUG INSERT, QUICK CONNECT	
62	1	1102.00445.00	ASSY, BREW BASKET LOCKER W/FEEDBACK	
63	1	1003.00259.00	BRACKET, BREW BASKET LOCK COVER	
64	2	1083.00009.00	WASHER, #6 SCREW , INTL TOOTH LOCKWASHER	
65	1	1084.00010.00	NUT, HEX, #6-32, UNDERSIZED, ZINC PLATED	
66	3	1073.00007.00	LEG, FLANGE FOOT, 4" HIGH	
67	1	1086.00008.00	CONNECTOR, CLAMP, NON-METALLIC CABLE, 3/4"	
68	1	1086.00031.00	SKINTOP, 3/4" NPT, 0.354" - 0.630" DIA CABLE, BLK	
69	1	1086.00032.00	LOCKNUT, SKINTOP, 3/4" NPT, BLACK HEX	
70	1	1044.00013.00	LABEL EQUIPOTENTIALITY, CE	
71	1	1052.00027.00	EMI FILTER, THREE LINE 30A, 250/440VAC	
72	1	1084.00012.00	NUT, HEX, #6-32 MACHINE SCREW	



CBS-2252 Hot water tank  
 1104.00160.00; 1104.00162.00; 1104.00163.00  
 3 X 3kW; 3 X 4 kW & 3 x 5 kW

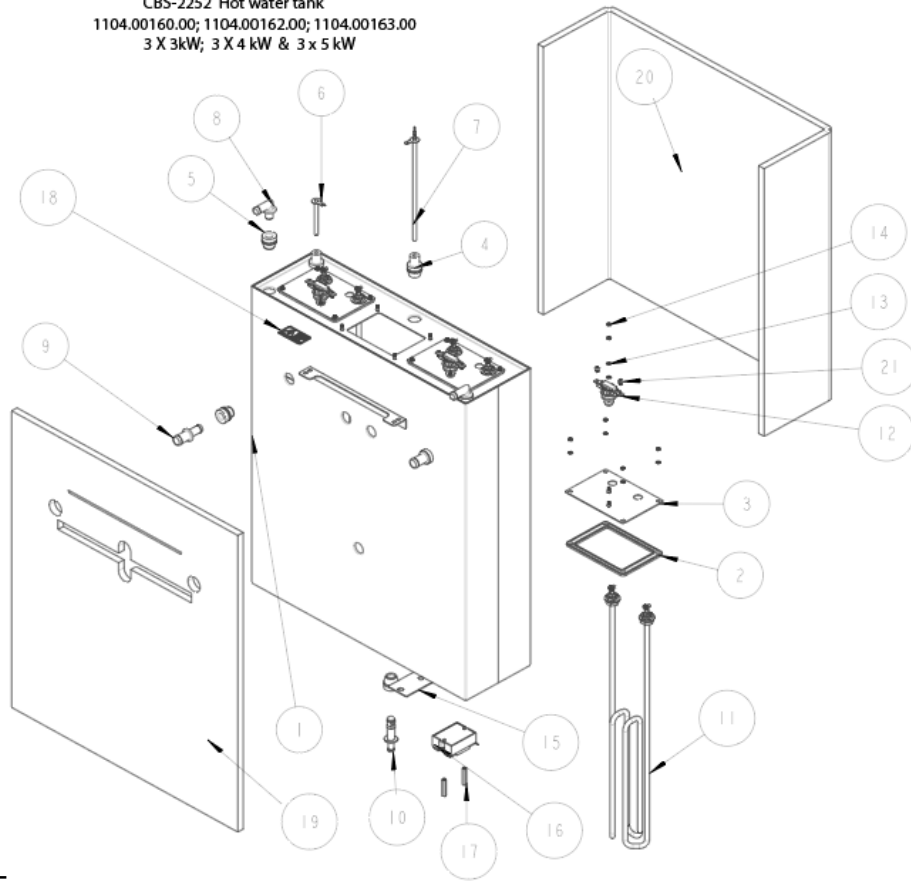

CBS-2252 Hot Water Tank Drawing 1104.00161.00 & 1104.00164.00

Ref#	Qty	Part number	Description
1	1	1114.00164.00	WELDMENT TANK, CBS-2252, LASER
2	3	1024.00115.00	TANK GASKET - NG HEATER PLATE, ONE ELEMENT
3	3	1114.00181.00	WELDMENT TANK HEATER BRACKET, NG-2232
4	5	1024.00050.00	GROMMET, SILICONE, 11.4mm ID
5	1	1023.00166.00	FITTING, COLD WATER INLET, GROMMET DESIGN
6	2	1023.00203.00	FITTING, STRAIGHT, GROMMET, .625"
7	2	1003.00140.00	ALUMINUM BRACKET FOR SSR
8	2	1052.00033.00	RELAY, SOLID STATE, 50A/480VAC, W/BUILD IN VARISTOR
9	4	1081.00042.00	STANDOFF, 1/4" HEX
10	3	1107.00005.00	ASSEMBLY, IMMERSION HEATER, 3000W, 240VAC
10	3	1107.00007.00	ASSEMBLY, IMMERSION HEATER, 4000W, 240VAC
10	3	1107.00032.00	ASSEMBLY, IMMERSION HEATER, 5000W, 240VAC
11	2	1024.00053.00	LEVEL AND TEMP PROBE GROMMET
12	2	1023.00212.00	FITTING, ELBOW, GROMMET, .500"
13	1	1112.00019.00	PROBE WELDMENT, WATER LEVEL 2.600" LG
14	1	1102.00161.00	PROBE ASSEMBLY, TEMP. AND LLC, 8" LONG
15	2	1053.00052.00	THERMOSTAT, SINGLE SHOT, SCREW CONNECTIONS, 240V/25A
16	16	1083.00009.00	WASHER, #6 SCREW , INTL TOOTH LOCKWASHER
17	16	1084.00010.00	NUT, HEX, #6-32, UNDERSIZED, ZINC PLATED
18	2	1024.00054.00	GROMMET, SILICONE PLUG
19	1	1044.00004.00	LABEL, DANGER, HIGH VOLTAGE
20	1	1022.00070.00	INSULATION, TANK FRONT, CBS-2152
21	1	1022.00071.00	INSULATION, TANK BACK, CBS-2152
22	4	1082.00136.00	BRASS SCREW, #8-32 X 1/4", PHILLIPS PAN HEAD



CBS-2252 Hot water tank  
 1104.00161.00; 1104.00164.00  
 2 X 3kW; 2x 5 kW

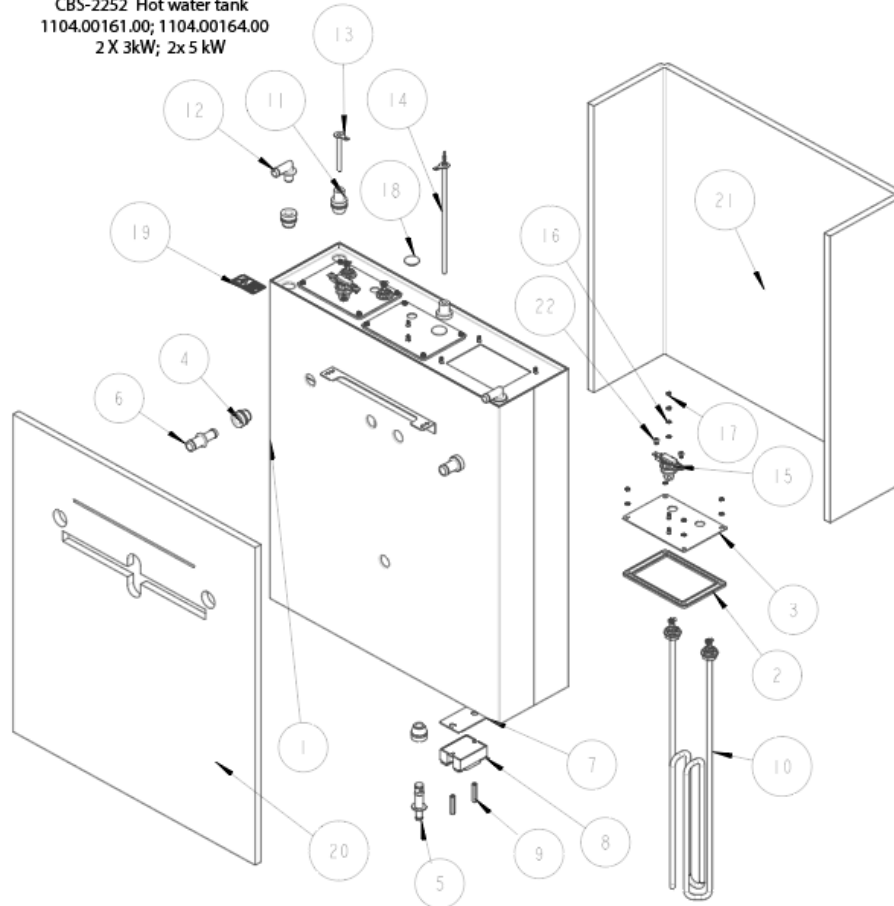

CBS-2252 Hot Water Tank Drawing 1104.00161.00 & 1104.00164.00

Ref#	Qty	Part number	Description
1	1	1114.00164.00	WELDMENT TANK, CBS-2252, LASER
2	3	1024.00115.00	TANK GASKET - NG HEATER PLATE, ONE ELEMENT
3	3	1114.00181.00	WELDMENT TANK HEATER BRACKET, NG-2232
4	5	1024.00050.00	GROMMET, SILICONE, 11.4mm ID
5	1	1023.00166.00	FITTING, COLD WATER INLET, GROMMET DESIGN
6	2	1023.00203.00	FITTING, STRAIGHT, GROMMET, .625"
7	2	1003.00140.00	ALUMINUM BRACKET FOR SSR
8	2	1052.00033.00	RELAY, SOLID STATE, 50A/480VAC, W/BUILD IN VARISTOR
9	4	1081.00042.00	STANDOFF, 1/4" HEX
10	2	1107.00005.00	<b>ASSEMBLY, IMMERSION HEATER, 3000W, 240VAC</b>
10	2	1107.00032.00	<b>ASSEMBLY, IMMERSION HEATER, 5000W, 240VAC</b>
11	2	1024.00053.00	LEVEL AND TEMP PROBE GROMMET
12	2	1023.00212.00	FITTING, ELBOW, GROMMET, .500"
13	1	1112.00019.00	PROBE WELDMENT, WATER LEVEL 2.600" LG
14	1	1102.00161.00	PROBE ASSEMBLY, TEMP. AND LLC, 8" LONG
15	2	1053.00052.00	THERMOSTAT, SINGLE SHOT, SCREW CONNECTIONS, 240V/25A
16	16	1083.00009.00	WASHER, #6 SCREW , INTL TOOTH LOCKWASHER
17	16	1084.00010.00	NUT, HEX, #6-32, UNDERSIZED, ZINC PLATED
18	2	1024.00054.00	GROMMET, SILICONE PLUG
19	1	1044.00004.00	LABEL, DANGER, HIGH VOLTAGE
20	1	1022.00070.00	INSULATION, TANK FRONT, CBS-2152
21	1	1022.00071.00	INSULATION, TANK BACK, CBS-2152
22	4	1082.00136.00	BRASS SCREW, #8-32 X 1/4", PHILLIPS PAN HEAD



# Parts Diagrams CBS-2251

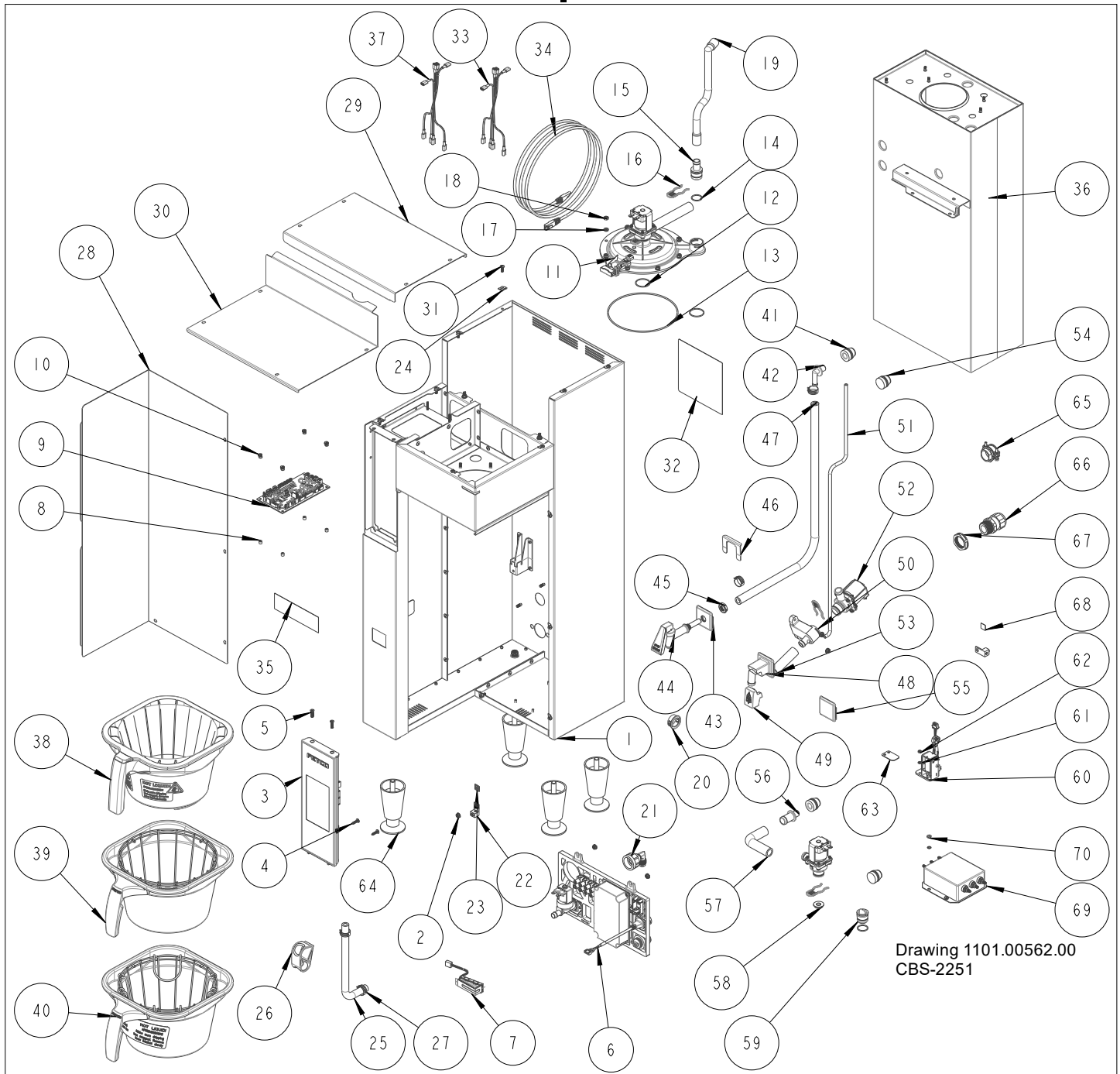

Ref	Qty	Part Number	Description	Drawing 1101.00562.00 CBS-2251
1	1	1111.00100.00	WELDMENT BODY, CBS-2251	
2	8	1084.00051.00	NUT, HEX LOCKWASHER, #8-32, 18-8 ST. STL.	
3	1	1102.00448.00	FRONT PANEL ASSEMBLY, CBS-2200 SERIES	
4	2	1082.00020.00	SCREW, #6 X 5/8, TRUSS HD PHIL, SHEET MTL	
5	2	1082.00058.00	SCREW, # 8-32 X 5/8, FLAT HD, PH, 18-8 SS	
6	1	1102.00449.00	ELECTRICAL COMPONENT LATTICE, CBS-2200 <b>Please see page 26 for full parts list</b>	
7	1	1102.00444.00	VISUAL COMMUNICATION RGB LED BAR, ASSY	
8	4	1081.00006.00	SPACER, 6MM OD x 3.2MM ID x 5MM LG, Z/P	
9	1	1051.00046.00	CBS-2200 SERIES, I/O BOARD, 24V	
10	4	1029.00006.00	NUT, FINGER KNURLED, #4-40	
			Parts list continues next page	



Ref	Qty	Part Number	Description	Drawing 1101.00562.00 CBS-2251 ...Continued from page 21
11	1	1102.00450.00	QUICK CONNECT SPRAYHEAD ASSEMBLY, BASIC	<b>Please see page 27 for full parts list</b>
12	2	1024.00107.00	O-RING, 1 3/16" OD X 1 1/16" ID X 1/16" TH, BYPASS SEAL	
13	1	1024.00108.00	O-RING, 5 11/16"OD X 5 1/2" ID X 3/32" TH, BREW SEAL	
14	2	1024.00106.00	O-RING, 13/16"OD X 11/16"ID X 1/16" TH, FOR QUICK CONNECT	
15	1	1023.00343.00	VENT INSERT, QUICK CONNECT	
16	3	1023.00342.00	QUICK CONNECT CLIP	
17	8	1083.00010.00	WASHER, #10 SCREW W/NEOPRENE-BONDED SEAL	
18	8	1084.00006.00	NUT, 8-32 18-8 HEX MACHINE SCREW	
19	1	1024.00098.00	VENT TUBE, CBS-XTS/XV+ EXTRACTOR SERIES	
20	1	1086.00004.00	BUSHING, SNAP, 1" MOUNTING HOLE	
21	1	1102.00243.00	ADAPTER ASSY, 3/4" BSP x 1/4" NPT x 3/8" TUBE	
22	2	1065.00009.00	GROUND LUG CONNECTOR, 14-2 AWG, ALUMINUM	
23	1	1044.00012.00	LABEL GROUND, CE	
24	12	1084.00011.00	NUT, CLIP ON (J-NUT), #6-32, 22-20 GA., BLK-PH FINISH	
25	1	1025.00058.00	TUBE, 9/16"OD X 5/16"ID X 25.00"LG	
26	1	1086.00009.00	CLAMP, 3/4" MAX TUBE OD FLOW CONTROL	
27	4	1086.00003.00	UNICLAMP, 15.9 HOSE OD CLAMP	
28	1	1112.00529.00	WELDMENT FRONT COVER, CBS-2250	
29	1	1001.00402.00	COVER TOP, CBS-2251	
30	1	1001.00403.00	COVER, UPPER BASE, CBS-2251	
31	12	1082.00017.00	SCREW, TRUSS HD. PHIL. MACHINE, # 6-32 X 1/2 LG.	
32	1	1046.00035.00	LABEL, WARNING "TO REDUCE RISK OF ELECTRIC SHOCK OR FIRE"	
33	1	1402.00106.00	HARNESS, CBS-2240/50-NG, LOW AMP, UNIVERSAL	
34	1	1063.00042.00	ETHERNET CABLE, CAT-7, 5FT LENGTH	
35	1	1046.00003.00	LABEL, CSD WARNING, 1.5" X 5.0"	
36	1	1104.00167.00	COMPLETE TANK ASSEMBLY, CBS-2251, 2 X 2.3KW/240VAC	
36	1	1104.00168.00	COMPLETE TANK ASSEMBLY, CBS-2251, 2 X 3KW/240VAC	
36	1	1104.00165.00	COMPLETE TANK ASSEMBLY, CBS-2251, 2 X 4KW/240VAC	
36	1	1104.00166.00	COMPLETE TANK ASSEMBLY, CBS-2251, 2 X 5KW/240VAC	
37	1	1402.00061.01	HARNESS HIGH AMP, CBS-1151-XV+	
38	1	B015280BN2	BB ASSEMBLY, 16" x 6", Ø.280" HOLE	<b>Please see page 28 for full parts list</b>
39	1	B001280B1	BB ASSY, 16" X 6", 0.280 DIA HOLE, BLACK	
40	1	B002280B1	BB ASSY, 16" X 6", 0.280" DIA HOLE, BLACK	
41	2	1024.00050.00	GROMMET, SILICONE, 11.4mm ID	
42	1	1023.00183.00	FITTING, ELBOW, GROMMET, .375"	
43	1	1023.00348.00	HOT WATER INSERT, MANUAL FAUCET	
44	1	1071.00055.00	FAUCET, HOT WATER, PSC-BR-8, WITH FLAT AND STEM	
45	1	1084.00048.00	JAM NUT, 1/2-20 UNF, NICKEL PLATED BRASS	
46	1	1003.00370.00	HOT WATER INSERT LOCK	
47	1	1025.00082.00	TUBE, 5/8"OD X 3/8"ID X 19.00"LG.	
48	1	1023.00346.00	HOT WATER INSERT, AUTO FAUCET	
49	1	1029.00041.00	COVER, AUTO HOT WATER FAUCET, SILICONE	
50	1	1023.00347.00	VALVE MOUNT, HOT WATER DISPENSER	
51	1	1025.00026.00	TUBE, 1/4"OD X 1/8"ID X 25"LG, VENT, HOT WATER VAPOR	
52	2	1057.00076.00	VALVE ASSEMBLY, COMPLETE, NG, DELTROL	
53	1	1025.00138.00	TUBE, SILICONE, 3/4" OD X 1/2" ID X 2.5" LG, HOT WATER	
54	2	1024.00051.00	GROMMET, SILICONE, BLANK	
55	1	1023.00349.00	HOT WATER INSERT, NO FAUCET	
56	1	1023.00203.00	FITTING, STRAIGHT, GROMMET, .625"	
57	1	1025.00136.00	TUBE, SILICONE, 3/4" OD X 1/2" ID X 4.25" LG, BREW	
58	1	1023.00345.00	ORIFICE INSERT, QUICK CONNECT, 5/16" HOLE	
59	1	1023.00344.00	PLUG INSERT, QUICK CONNECT	
60	1	1102.00445.00	ASSY, BREW BASKET LOCKER W/FEEDBACK	
61	6	1083.00009.00	WASHER, #6 SCREW, INTL TOOTH LOCKWASHER	
62	2	1084.00010.00	NUT, HEX, #6-32, UNDERSIZED, ZINC PLATED	
63	1	1003.00259.00	BRACKET, BREW BASKET LOCK COVER	
64	4	1073.00007.00	LEG, FLANGE FOOT, 4" HIGH	
65	1	1086.00008.00	CONNECTOR, CLAMP, NON-METALLIC CABLE, 3/4"	
66	1	1086.00031.00	SKINTOP, 3/4" NPT, 0.354" - 0.630" DIA CABLE, BLK	
67	1	1086.00032.00	LOCKNUT, SKINTOP, 3/4" NPT, BLACK HEX	
68	1	1044.00013.00	LABEL EQUIPOTENTIALITY, CE	
69	1	1052.00027.00	EMI FILTER, THREE LINE 30A, 250/440VAC	
70	4	1084.00012.00	NUT, HEX, #6-32 MACHINE SCREW	



CBS-2251 Hot water tank  
 1104.00165.00 and 1104.00166.00  
 1 X 4 kW & 1 x 5 kW

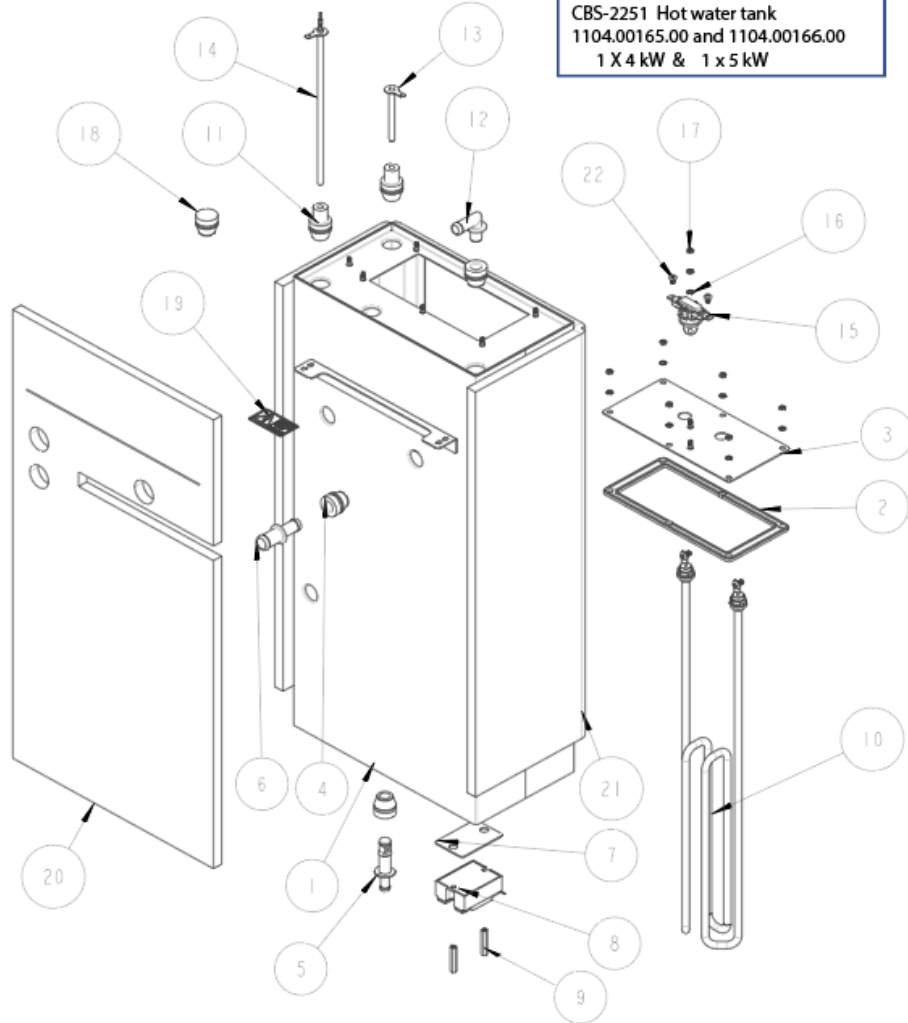

TANK ASSY, CBS-2251 Single Heater Drawing number 1104.000165.00 & 1104.000166.00

REF	QTY	Part number	Description
1	1	1114.00172.00	WELDMENT, TANK, CBS-2251
2	1	1024.00114.00	TANK GASKET - NG HEATER PLATE, TWO ELEMENT
3	1	1114.00184.00	WELDMENT TANK HEATER BRACKET, NG-2231, SINGLE
4	3	1024.00050.00	GROMMET, SILICONE, 11.4mm ID
5	1	1023.00166.00	FITTING, COLD WATER INLET, GROMMET DESIGN
6	1	1023.00203.00	FITTING, STRAIGHT, GROMMET, .625"
7	1	1003.00140.00	ALUMINUM BRACKET FOR SSR
8	1	1052.00033.00	RELAY, SOLID STATE, 50A/480VAC, W/BUILD IN VARISTOR
9	2	1081.00042.00	STANDOFF, 1/4" HEX
10	1	<b>1107.00037.00</b>	<b>HEATER ASSEMBLY, IMMERSION, 2300W, 240VAC</b>
10	1	<b>1107.00005.00</b>	<b>HEATER ASSEMBLY, IMMERSION, 3000W, 240VAC</b>
10	1	<b>1107.00007.00</b>	<b>HEATER ASSEMBLY, IMMERSION 4000W, 240VAC</b>
10	1	<b>1107.00032.00</b>	<b>HEATER ASSEMBLY, IMMERSION 5000W, 240VAC</b>
11	2	1024.00053.00	LEVEL AND TEMP PROBE GROMMET
12	1	1023.00212.00"	FITTING, ELBOW, GROMMET, .500
13	1	1112.00019.00	PROBE WELDMENT, WATER LEVEL 2.600" LG
14	1	1102.00161.00	PROBE ASSEMBLY, TEMP. AND LLC, 8" LONG
15	1	1053.00052.00	THERMOSTAT, SINGLE SHOT, SCREW CONNECTIONS, 240V/25A
16	8	1083.00009.00	WASHER, #6 SCREW, INTL TOOTH LOCKWASHER
17	8	1084.00010.00	NUT, HEX, #6-32, UNDERSIZED, ZINC PLATED
18	1	1044.00004.00	LABEL, DANGER, HIGH VOLTAGE
19	1	1024.00051.00	GROMMET, SILICONE, BLANK
20	1	1022.00068.00	INSULATION, TANK FRONT, CBS-2151
21	1	1022.00069.00	INSULATION, TANK BACK, CBS-2151
22	2	1082.00136.00	BRASS SCREW, #8-32 X 1/4", PHILLIPS PAN HEAD

CBS-2251 Hot water tank  
 1104.00167.00 and 1104.00168  
 2X 2.3 kW & 2x 3 kW

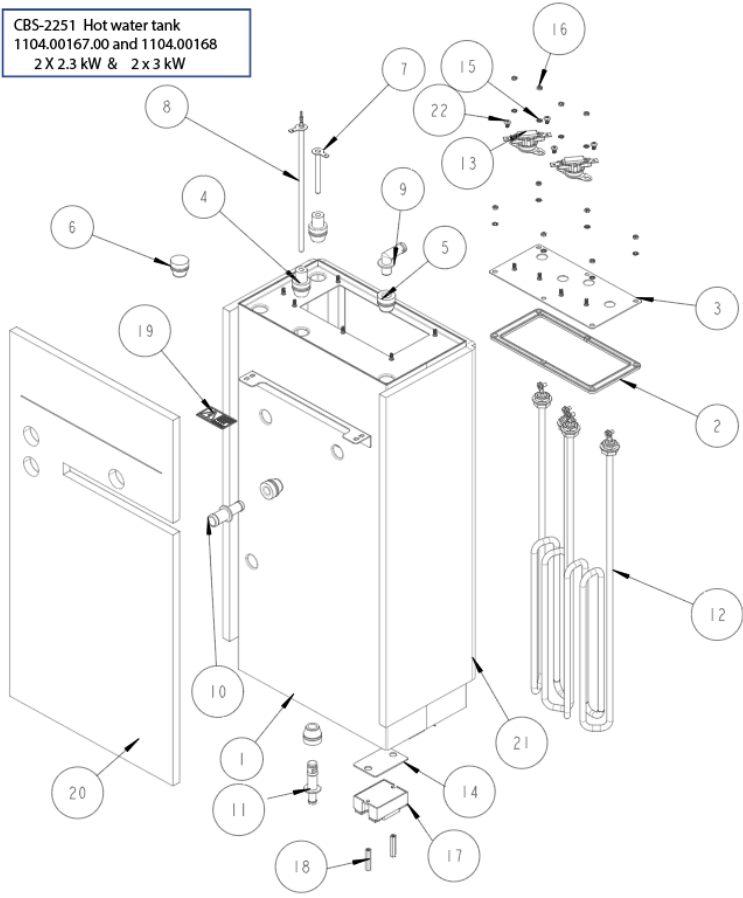

TANK ASSY, CBS-2251 Two Heater Drawing number 1104.000167.00 & 1104.00168.00

REF	QTY	Part number	Description
1	1	1114.00172.00	WELDMENT, TANK, CBS-2251
2	1	1024.00114.00	TANK GASKET - NG HEATER PLATE, TWO ELEMENT
3	1	1114.00176.00	WELDMENT TANK HEATER BRACKET, NG-2231
4	3	1024.00050.00	GROMMET, SILICONE, 11.4mm ID
5	1	1023.00166.00	FITTING, COLD WATER INLET, GROMMET DESIGN
6	1	1023.00203.00	FITTING, STRAIGHT, GROMMET, .625"
7	2	1003.00140.00	ALUMINUM BRACKET FOR SSR
8	2	1052.00033.00	RELAY, SOLID STATE, 50A/480VAC, W/BUILD IN VARISTOR
9	4	1081.00042.00	STANDOFF, 1/4" HEX
10	2	1107.00037.00	HEATER ASSEMBLY, IMMERSION, 2300W, 240VAC
10	2	1107.00005.00	HEATER ASSEMBLY, IMMERSION, 3000W, 240VAC
10	2	1107.00007.00	HEATER ASSEMBLY, IMMERSION 4000W, 240VAC
10	2	1107.00032.00	HEATER ASSEMBLY, IMMERSION 5000W, 240VAC
11	2	1024.00053.00	LEVEL AND TEMP PROBE GROMMET
12	1	1023.00212.00	FITTING, ELBOW, GROMMET, .500"
13	1	1112.00019.00	PROBE WELDMENT, WATER LEVEL 2.600" LG
14	1	1102.00161.00	PROBE ASSEMBLY, TEMP. AND LLC, 8" LONG
15	2	1053.00052.00	THERMOSTAT, SINGLE SHOT, SCREW CONNECTIONS, 240V/25A
16	10	1083.00009.00	WASHER, #6 SCREW , INTL TOOTH LOCKWASHER
17	10	1084.00010.00	NUT, HEX, #6-32, UNDERSIZED, ZINC PLATED
18	1	1024.00051.00	GROMMET, SILICONE, BLANK
19	1	1044.00004.00	LABEL, DANGER, HIGH VOLTAGE
20	1	1022.00068.00	INSULATION, TANK FRONT, CBS-2151
21	1	1022.00069.00	INSULATION, TANK BACK, CBS-2151
22	4	1082.00136.00	BRASS SCREW, #8-32 X 1/4", PHILLIPS PAN HEAD



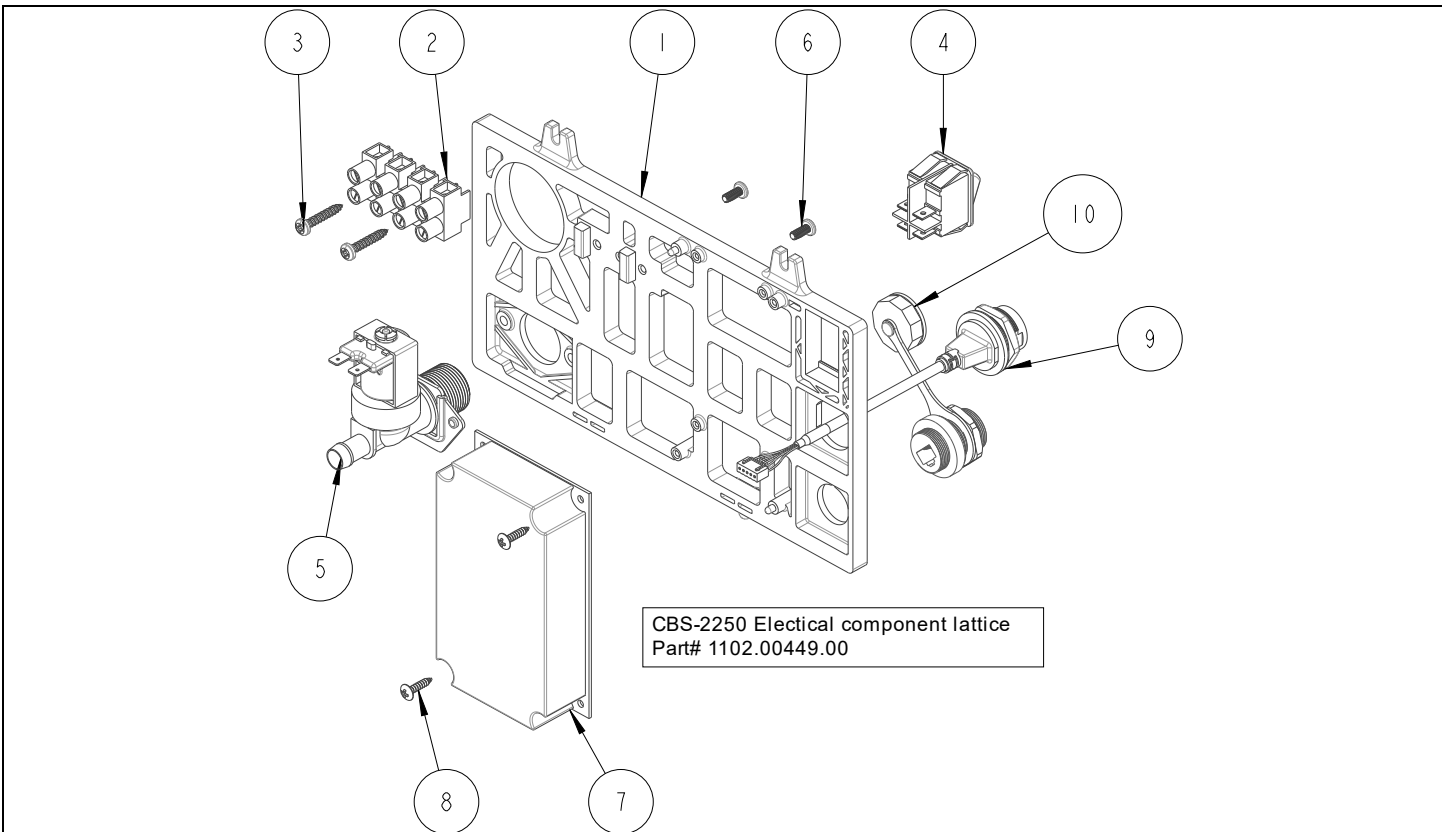

Ref	Qty	Part Number	Description	Electrical component lattice, CBS-2200 Part#1102.00449.00
		1102.00449.00	COMPLETE ELECTRICAL COMPONENT LATTICE, CBS-2200	
1	1	1023.00350.00	ELECTRICAL MOUNTING LATTICE, COMMON	
2	1	1052.00023.00	EUROSTRIP HE16 TERM. BLOCK, 4 POLE, 63 AMP, 18-8 AWG	
3	2	1082.00056.00	SCREW, #8-11 X 1" PAN HD PHIL, THREAD FORMING	
4	1	1058.00024.00	SWITCH, POWER, DOUBLE POLE, 16A, 125/250 VAC	
5	1	1057.00043.00	SOLENOID VALVE, 5.5L/min, 180 DEG, 24VDC	
6	2	1082.00010.00	SCREW, PAN HD. PHIL. MACH., M4x10 ZINC-PLATED	
7	1	1052.00059.00	POWER SUPPLY, 90-264VAC/24VDC, 2.25A	
8	2	1082.00020.00	SCREW, #6 X 5/8, TRUSS HD PHIL, SHEET MTL	
9	1	1058.00055.00	USB CONNECTOR	
10	1	1058.00162.00	ETHERNET PLUG IN CONNECTOR, W/COVER	



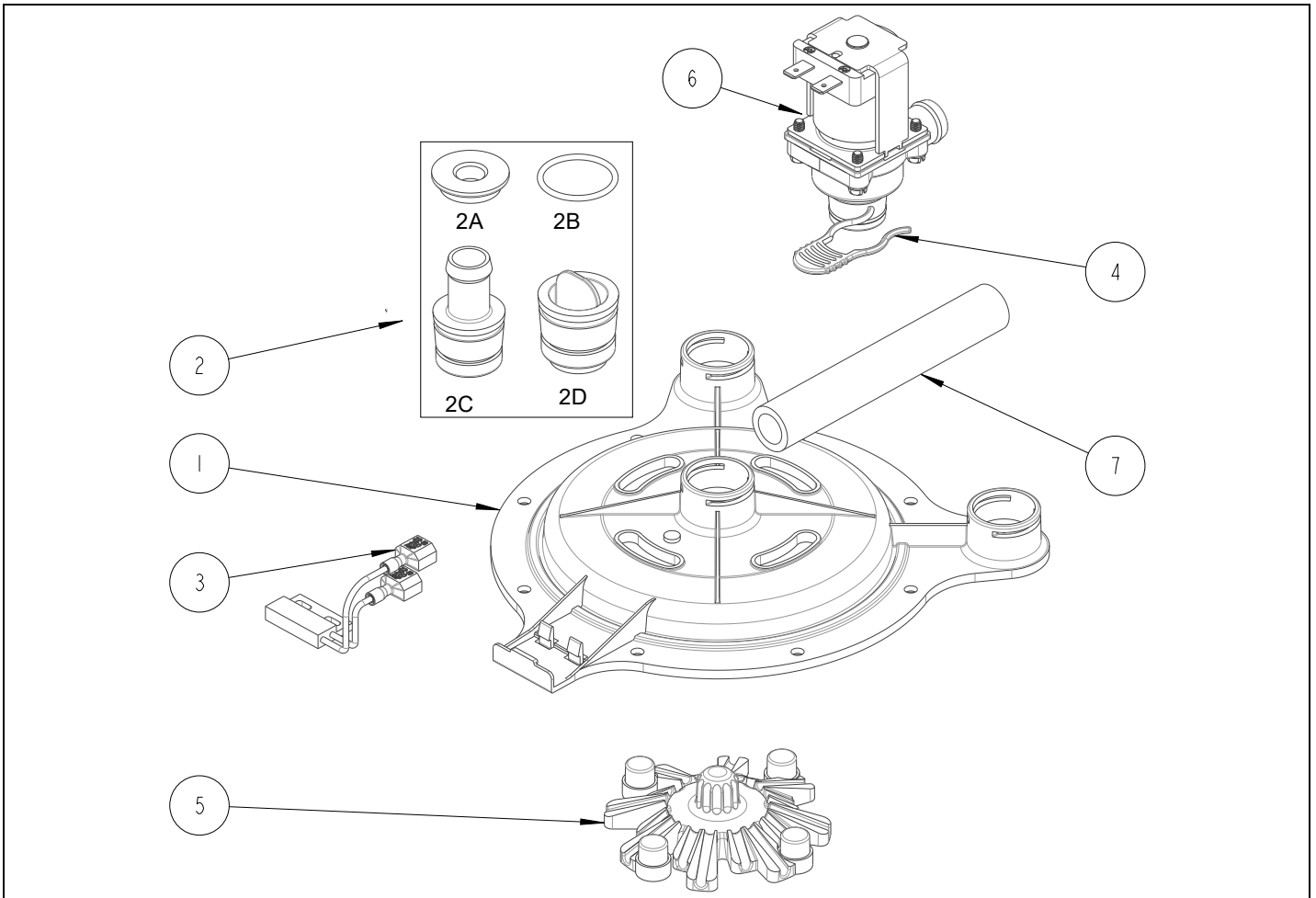

Ref	Qty	Part Number	Description	Drawing 1102.00450.00 QUICK CONNECT SPRAYHEAD
		1102.00450.00	COMPLETE QUICK CONNECT SPRAYHEAD ASSEMBLY, BASIC	
1	1	1023.00341.00	BASE, QUICK CONNECT SPRAYHEAD	
2A	1	1023.00345.00	(Bypass Valve) ORIFICE INSERT, QUICK CONNECT, 5/16" HOLE	
2B	3	1024.00106.00	O-RING, 13/16"OD X 11/16"ID X 1/16" TH, FOR QUICK CONNECT	
2C	1	1023.00343.00	VENT INSERT, QUICK CONNECT	
2D	~	1023.00344.00	PLUG INSERT, QUICK CONNECT	
3	1	1102.00113.00	SWITCH, REED, ASSEMBLY	
4	3	1023.00342.00	QUICK CONNECT CLIP	
5	1	1102.00043.00	CASCADE SPRAY DOME, CBS-2050/60'S	
6	1 or 2	1057.00076.00	VALVE ASSEMBLY, COMPLETE, NG, DELTROL	
7	1	1025.00136.00	TUBE, SILICONE, 3/4" OD X 1/2" ID X 4.25" LG, BREW	

Stainless Steel Brew Baskets

	Ref#	Part Number	Description
		B001280B1	Complete Stainless Steel Brew basket <u>no clips</u>
	←	B002280B1	Complete Stainless Steel Brew basket <u>with clips</u>
	1	1112.00058.00	BB brew cone W/LDMNT
	2	1046.00025.00	BREW BASKET WARNING LABEL
	3	1082.00040.00	SCREW, 1/4-20 X .5, FL HD, PH., W/NYLN
	4	1009.00005.00	WIRE BASKET
	5	1102.00064.00	HANDLE W/MAGNET ASY, BLACK
	6	1009.00003.00	CLIP, WIRE BASKET, NOTE!: <b>Requires 4 clips</b>
	Optional colored handle	1102.00065.00	HANDLE W/MAGNET RED
	Optional colored handle	1102.00066.00	HANDLE W/MAGNET GREEN
	Optional colored handle	1102.00067.00	HANDLE W/MAGNET ORANGE

Plastic Brew Basket Parts

Part Number B015280BN2 – Complete Plastic Brew Basket

<p><i>Brown colored insert is standard</i></p> <p>→</p> <p>Brew basket handle plug for polymeric brew baskets is available in optional colors.</p>	Part Number	Plug Insert color
	1023.00195.00	BROWN PLUG, BB HANDLE
	1023.00194.00	BLACK PLUG, BB HANDLE
	1023.00190.00	RED PLUG, BB HANDLE
	1023.00191.00	GREEN PLUG, BB HANDLE
	1023.00192.00	ORANGE PLUG, BB HANDLE
	1023.00180.00	BLUE PLUG, BB HANDLE



# Wiring Diagrams

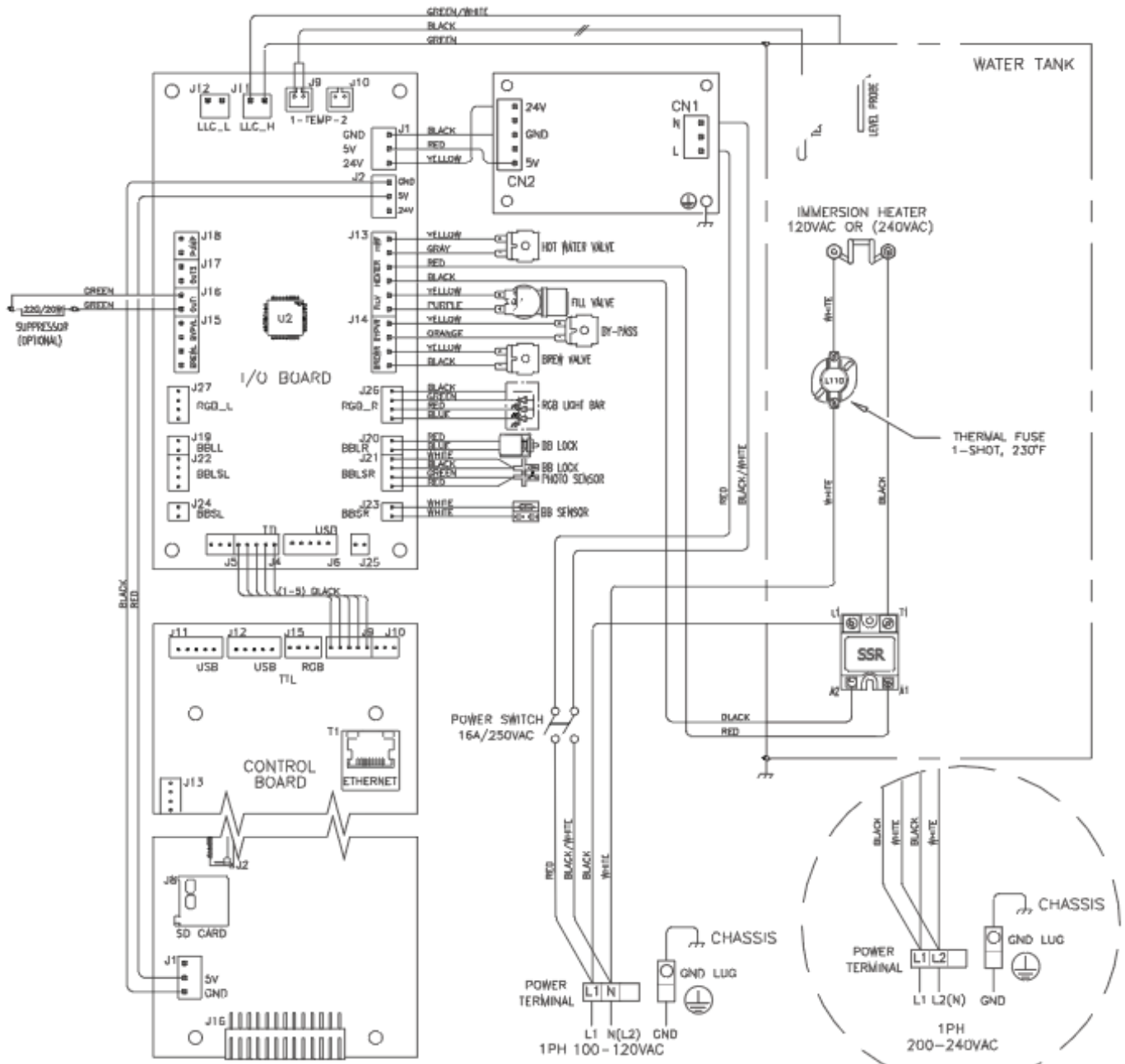

WIRING DIAGRAM, CBS-2200-NG, SINGLE, 1 HEATER, (L1, N(L2) + GND), 100-120VAC OR 200-240VAC, UL.

DRAWING NO. 1401.00177.10

**CBS-2251 Applies to SKU:**  
**E2251IN-1B140-PA110 E2251IN-1B150-PA110**

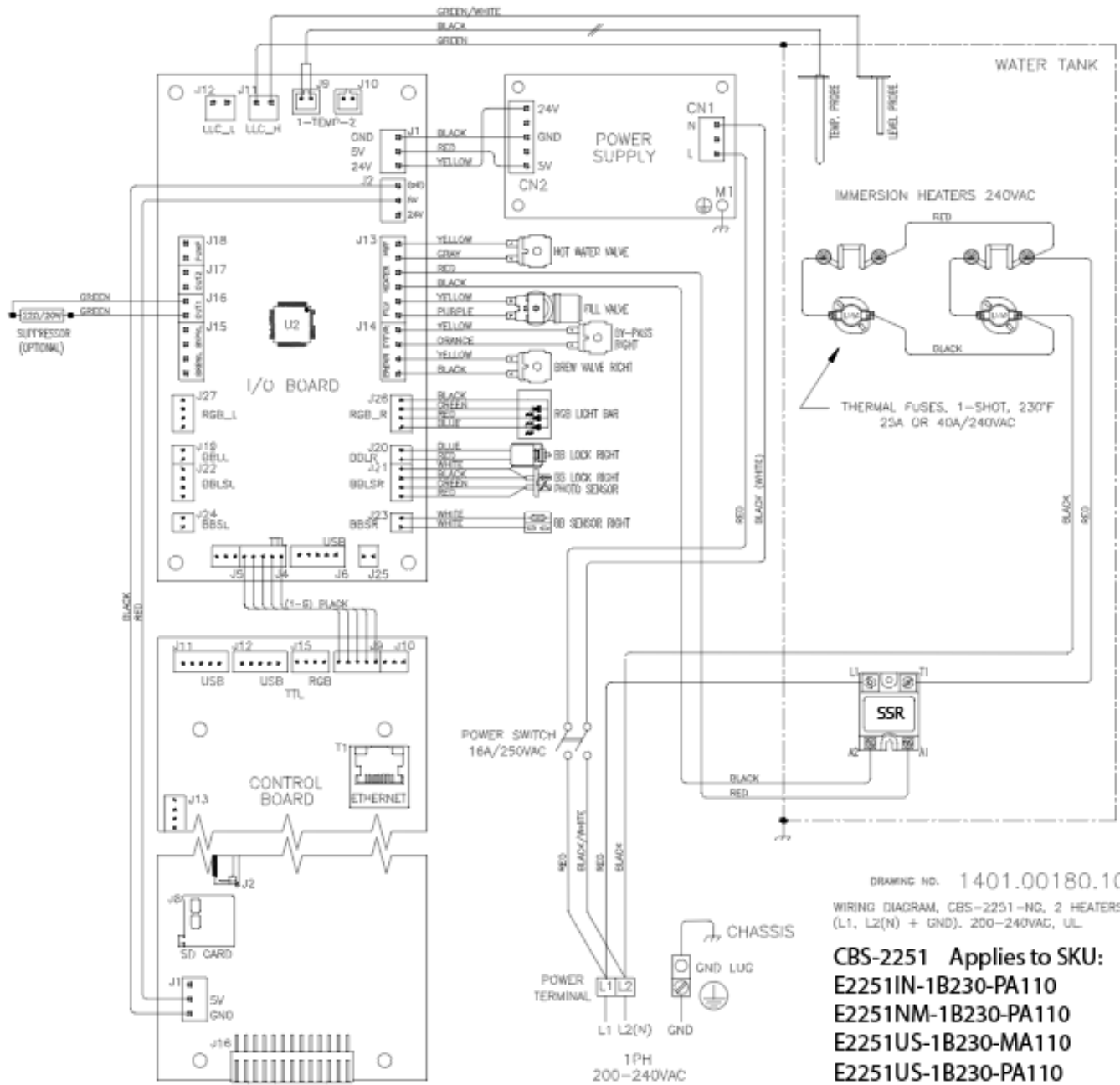

DRAWING NO. 1401.00180.10  
 WIRING DIAGRAM, CBS-2251-NG, 2 HEATERS,  
 (L1, L2(N) + GND). 200-240VAC, UL

**CBS-2251 Applies to SKU:**  
 E2251IN-1B230-PA110  
 E2251NM-1B230-PA110  
 E2251US-1B230-MA110  
 E2251US-1B230-PA110



DWG. NAME:  
 WIRING DIAGRAM, CBS-2200-NG  
 2 OR 3 HEATERS, UNIVERSAL  
 (L1, (L2), L3 + GND)  
 1 OR 3-PH, 200-240VAC, UL

DRAWING NO.  
 1401.00176.10

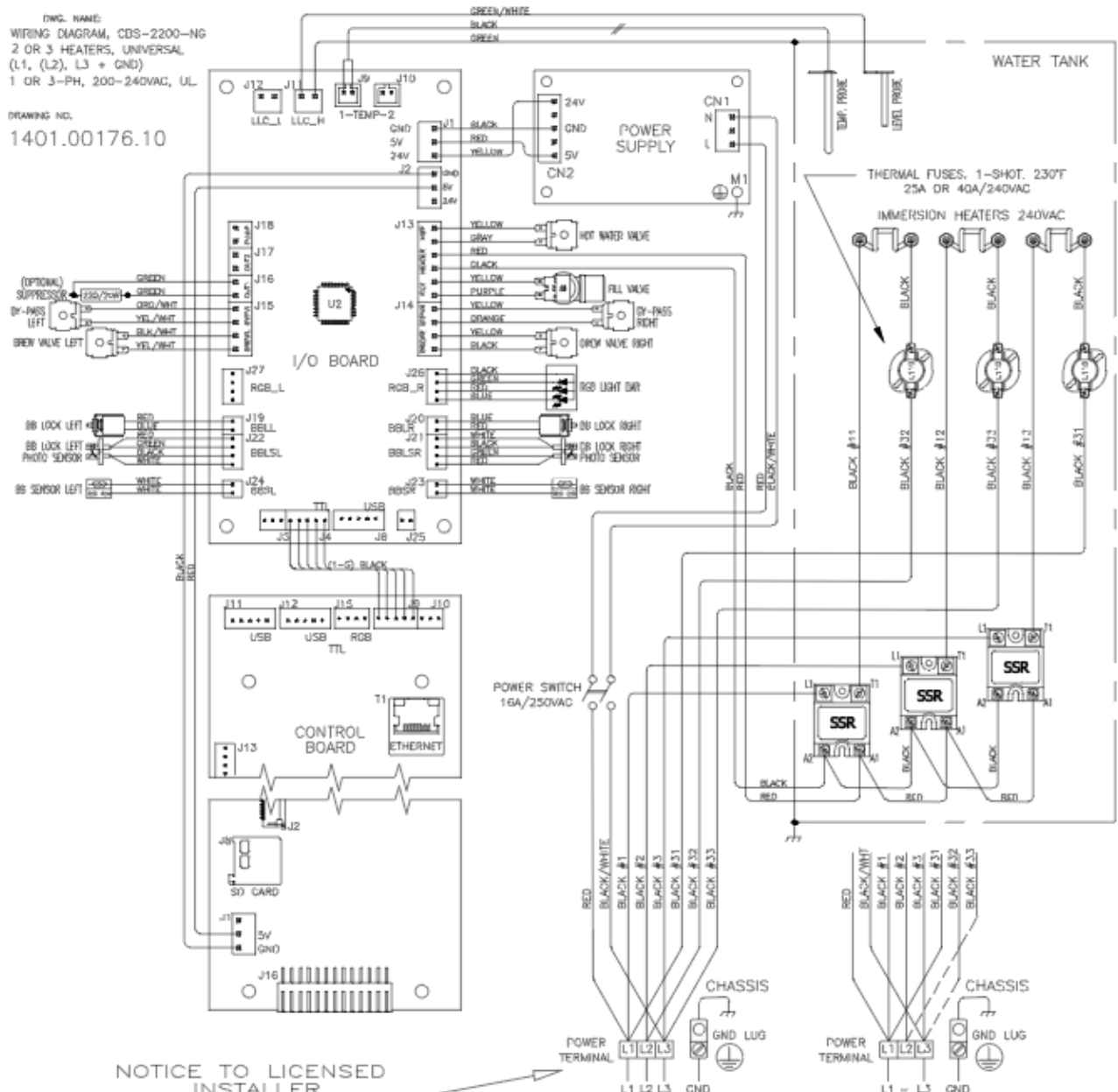

NOTICE TO LICENSED INSTALLER

THREE PHASE	SINGLE PHASE
POWER L1, L2, & L3	POWER L1 & L3 L2 - NOT CONNECTED
L1 - #1, #31	L1 - #1, #31
L2 - #2, #32	L2 - #2, #33
L3 - #3, #33	L3 - #3, #32
POWER TERMINAL CONNECTION	
3PH 200-240VAC	
1PH 200-240VAC	

CBS-2253plus & CBS-2253plus Field configurable wiring  
 Field configurable models are shipped in single phase configuration  
 To change to three phase configuration: switch black wire 32 & 33  
 (Move wire 32 from L3 to L2. Move wire 33 from L2 to L3)

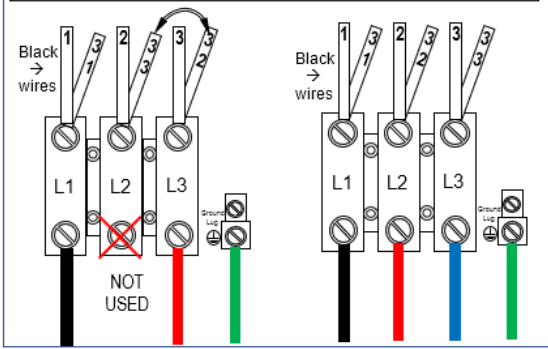

CBS-22532 and CBS-2253  
 Applies to SKU: E2252NM-UB250-PA110; E2252US-UB230-PA110-HIL;  
 E2252US-UB230-MA110; E2252US-UB230-PA110; E2252US-UB250-MA110;  
 E2252US-UB250-PA110, E2253NM-UB250-PA110; E2253US-UB230-MA110;  
 E2253US-UB230-PA110; E2253US-UB250-MA110; E2253US-UB250-PA110

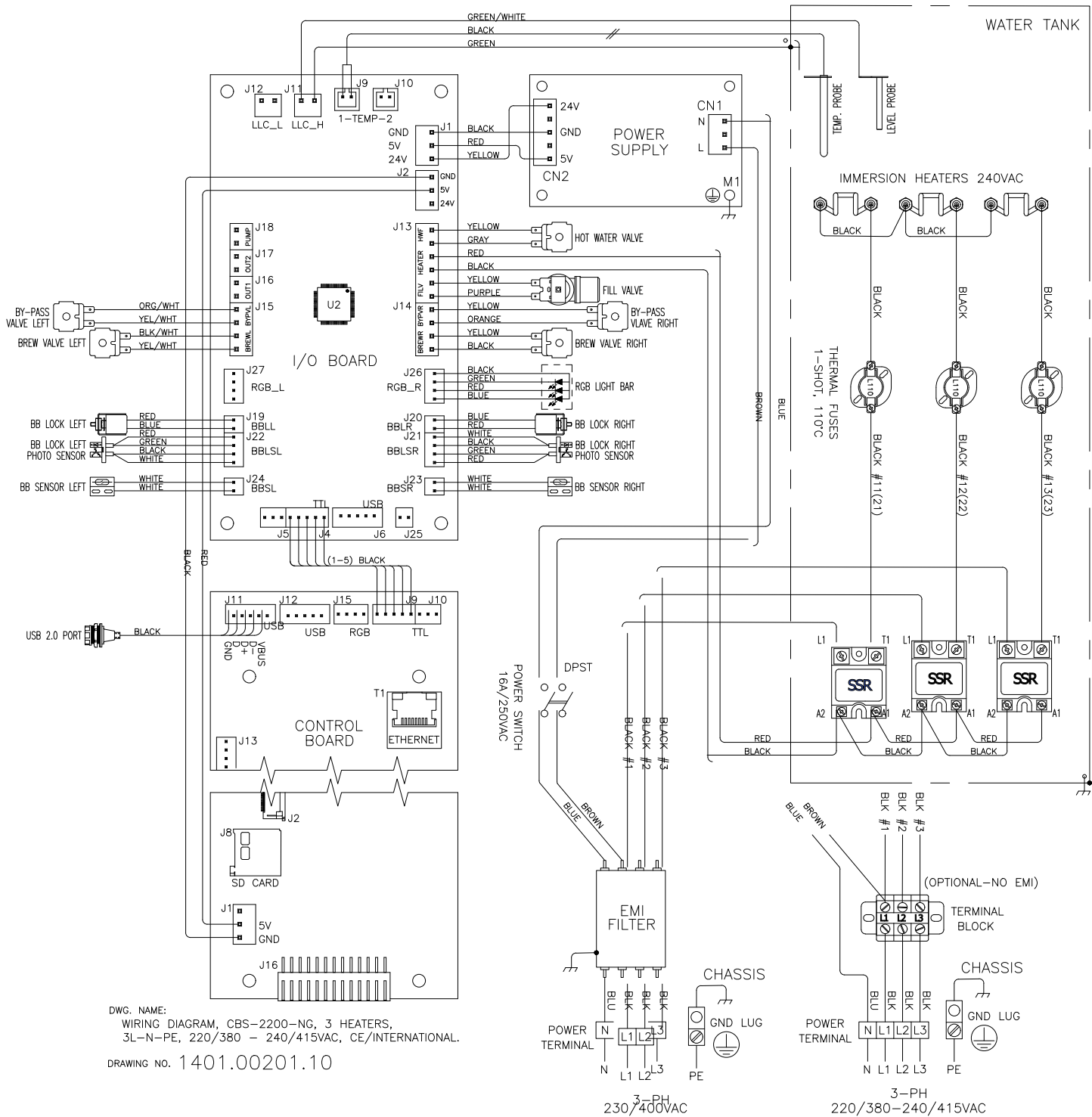

DWG. NAME: WIRING DIAGRAM, CBS-2200-NG, 3 HEATERS, 3L-N-PE, 220/380 - 240/415VAC, CE/INTERNATIONAL.  
DRAWING NO. 1401.00201.10

Applies to SKU: E2253CE-3B350-PA110,  
E2253CE-3B350-PM110, E2253IN-3B330-PA110,  
E2253IN-3B340-PA110, E2253IN-3B350-PA110

