

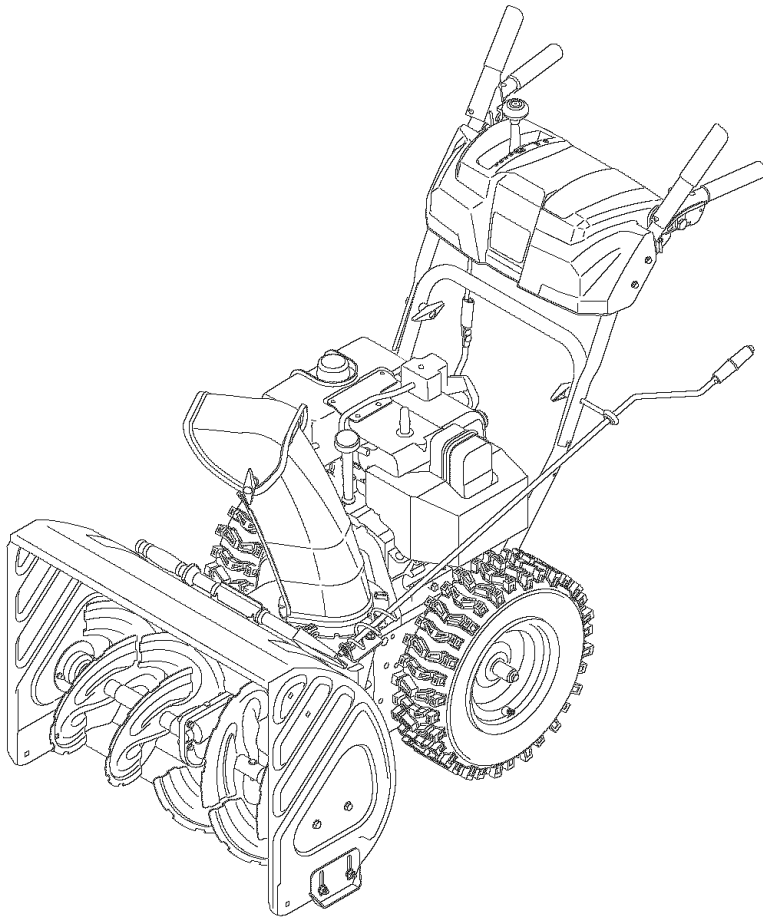

Operator's Manual



Two-Stage Snow Thrower 5524—Storm

IMPORTANT: READ SAFETY RULES AND INSTRUCTIONS CAREFULLY

WARNING: This unit is equipped with an internal combustion engine and should not be used on or near any unimproved forest-covered, brush-covered or grass-covered land unless the engine's exhaust system is equipped with a spark arrester meeting applicable local or state laws (if any). If a spark arrester is used, it should be maintained in effective working order by the operator. In the State of California the above is required by law (Section 4442 of the California Public Resources Code). Other states may have similar laws. Federal laws apply on federal lands. A spark arrester for the muffler is available through your nearest engine authorized service dealer or contact the service department, P.O. Box 361131 Cleveland, Ohio 44136-0019.

TROY-BILT LLC, P.O. BOX 361131 CLEVELAND, OHIO 44136-0019

TABLE OF CONTENTS

Content	Page	Content	Page
Important Safe Operation Practices	3	Maintaining Your Snow Thrower	15
Assembling Your Snow Thrower	6	Servicing Your Snow Thrower	15
Know Your Snow Thrower	8	Troubleshooting	20
Operating Your Snow Thrower	10	Illustrated Parts List	22
Making Adjustments	13	Warranty	Back Cover

FINDING MODEL NUMBER

This Operator's Manual is an important part of your new rear-tine tiller. It will help you assemble, prepare and maintain the unit for best performance. Please read and understand what it says.



Before you start assembling your new equipment, please locate the model plate on the equipment and copy the information from it in the space provided below. A sample model plate is also given below. You can locate the model plate by standing behind the unit and looking down at rear surface of the frame. This information will be necessary to use the manufacturer's web site and/or help from the Customer Support Department or an authorized service dealer.

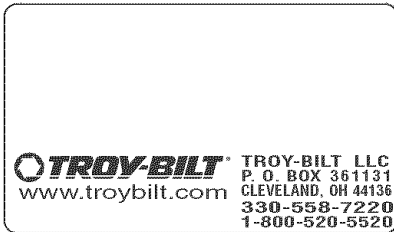

Copy the model number here: _____

Copy the serial number here: _____

CUSTOMER SUPPORT

Please do NOT return the unit to the retailer from which it was purchased, without first contacting Customer Support.

If you have difficulty assembling this product or have any questions regarding the controls, operation or maintenance of this unit, you can seek help from the experts. Choose from the options below:

	<p>Visit troy-bilt.com for many useful suggestions. Click on Customer Support button and you will get the four options reproduced here. Click on the appropriate button and help is immediately available.</p> <div style="border: 1px solid black; padding: 5px; margin: 10px auto; width: 80%;"> <p>Find Answers Click here to search our knowledge base. Search by product, keyword, or phrase.</p> <hr/> <p>My Stuff Login to check the status of your questions, modify your inquiries, or update your personal profile.</p> <hr/> <p>Service Locator Need local assistance? Click here to find authorized service centers in your area.</p> <hr/> <p>Manuals Online Need a manual and/or parts list? Download literature from recent model years.</p> </div> <p style="text-align: right; font-style: italic; margin-top: 10px;">The answer you are looking for could be just a mouse-click away!</p>
	<p>If you prefer to reach a Customer Support Representative, please call 1(800) 520-5520.</p>
	<p>The engine manufacturer is responsible for all engine-related issues with regard to performance, power-rating, specifications, warranty and service. Please refer to the engine manufacturer's Owner's/Operator's Manual, packed separately with your unit, for more information.</p>

SECTION 1: IMPORTANT SAFE OPERATION PRACTICES



WARNING: Engine Exhaust, some of its constituents, and certain vehicle components contain or emit chemicals known to the State of California to cause cancer, birth defects or other reproductive harm.



DANGER: This machine was built to be operated according to the rules for safe operation in this manual. As with any type of power equipment, carelessness or error on the part of the operator can result in serious injury. This machine is capable of amputating hands and feet and throwing objects. Failure to observe the following safety instructions could result in serious injury or death.

Training

1. Read, understand, and follow all instructions on the machine and in the manual(s) before attempting to assemble and operate. Keep this manual in a safe place for future and regular reference and for ordering replacement parts.
2. Be familiar with all controls and their proper operation. Know how to stop the machine and disengage them quickly.
3. Never allow children under 14 years old to operate this machine. Children 14 years old and over should read and understand the operation instructions and safety rules in this manual and should be trained and supervised by a parent.
4. Never allow adults to operate this machine without proper instruction.
5. Thrown objects can cause serious personal injury. Plan your snow-throwing pattern to avoid discharge of material toward roads, bystanders and the like.
6. Keep bystanders, helpers, pets and children at least 75 feet from the machine while it is in operation. Stop machine if anyone enters the area.
7. Exercise caution to avoid slipping or falling, especially when operating in reverse.
4. Use a grounded three-wire extension cord and receptacle for all units with electric start engines.
5. Adjust collector housing height to clear gravel or crushed rock surfaces.
6. Disengage all control levers before starting the engine.
7. Never attempt to make any adjustments while engine is running, except where specifically recommended in the operator's manual.
8. Let engine and machine adjust to outdoor temperature before starting to clear snow.
9. To avoid personal injury or property damage use extreme care in handling gasoline. Gasoline is extremely flammable and the vapors are explosive. Serious personal injury can occur when gasoline is spilled on yourself or your clothes, which can ignite. Wash your skin and change clothes immediately.
 - a. Use only an approved gasoline container.
 - b. Extinguish all cigarettes, cigars, pipes and other sources of ignition.
 - c. Never fuel machine indoors.
 - d. Never remove gas cap or add fuel while the engine is hot or running.
 - e. Allow engine to cool at least two minutes before refueling.
 - f. Never over fill fuel tank. Fill tank to no more than ½ inch below bottom of filler neck to provide space for fuel expansion.
 - g. Replace gasoline cap and tighten securely.
 - h. If gasoline is spilled, wipe it off the engine and equipment. Move machine to another area. Wait 5 minutes before starting the engine.
 - i. Never store the machine or fuel container inside where there is an open flame, spark or pilot light (e.g. furnace, water heater, space heater, clothes dryer etc.).
 - j. Allow machine to cool at least 5 minutes before storing.

Preparation

1. Thoroughly inspect the area where the equipment is to be used. Remove all doormats, newspapers, sleds, boards, wires and other foreign objects, which could be tripped over or thrown by the auger/impeller.
2. Always wear safety glasses or eye shields during operation and while performing an adjustment or repair to protect your eyes. Thrown objects which ricochet can cause serious injury to the eyes.
3. Do not operate without wearing adequate winter outer garments. Do not wear jewelry, long scarves or other loose clothing, which could become entangled in moving parts. Wear footwear which will improve footing on slippery surfaces.

Operation

1. Do not put hands or feet near rotating parts, in the auger/impeller housing or chute assembly. Contact with the rotating parts can amputate hands and feet.
2. The auger/impeller control lever is a safety device. Never bypass its operation. Doing so makes the machine unsafe and may cause personal injury.
3. The control levers must operate easily in both directions and automatically return to the disengaged position when released.
4. Never operate with a missing or damaged chute assembly. Keep all safety devices in place and working.
5. Never run an engine indoors or in a poorly ventilated area. Engine exhaust contains carbon monoxide, an odorless and deadly gas.
6. Do not operate machine while under the influence of alcohol or drugs.
7. Muffler and engine become hot and can cause a burn. Do not touch.
8. Exercise extreme caution when operating on or crossing gravel surfaces. Stay alert for hidden hazards or traffic.
9. Exercise caution when changing direction and while operating on slopes.
10. Plan your snow-throwing pattern to avoid discharge towards windows, walls, cars etc. Thus, avoiding possible property damage or personal injury caused by a ricochet.
11. Never direct discharge at children, bystanders and pets or allow anyone in front of the machine.
12. Do not overload machine capacity by attempting to clear snow at too fast of a rate.
13. Never operate this machine without good visibility or light. Always be sure of your footing and keep a firm hold on the handles. Walk, never run.
14. Disengage power to the auger/impeller when transporting or not in use.
15. Never operate machine at high transport speeds on slippery surfaces. Look down and behind and use care when backing up.
16. If the machine should start to vibrate abnormally, stop the engine, disconnect the spark plug wire and ground it against the engine. Inspect thoroughly for damage. Repair any damage before starting and operating.
17. Disengage all control levers and stop engine before you leave the operating position (behind the handles). Wait until the auger/impeller comes to a complete stop before unclogging the chute assembly, making any adjustments, or inspections.
18. Never put your hand in the discharge or collector openings. Always use the clean-out tool provided to unclog the discharge opening. Do not unclog chute assembly while engine is running. Shut off engine and remain behind handles until all moving parts have stopped before unclogging.
19. Use only attachments and accessories approved by the manufacturer (e.g. wheel weights, tire chains, cabs etc.).
20. If situations occur which are not covered in this manual, use care and good judgment. Contact your dealer or call (800) 520-5520 for assistance and the name of your nearest servicing dealer.

Maintenance & Storage

1. Never tamper with safety devices. Check their proper operation regularly. Refer to the maintenance and adjustment sections of this manual.
2. Before cleaning, repairing, or inspecting machine disengage all control levers and stop the engine. Wait until the auger/impeller come to a complete stop. Disconnect the spark plug wire and ground against the engine to prevent unintended starting.
3. Check bolts and screws for proper tightness at frequent intervals to keep the machine in safe working condition. Also, visually inspect machine for any damage.
4. Do not change the engine governor setting or over-speed the engine. The governor controls the maximum safe operating speed of the engine.
5. Snow thrower shave plates and skid shoes are subject to wear and damage. For your safety protection, frequently check all components and replace with original equipment manufacturer's (OEM) parts only. "Use of parts which do not meet the original equipment specifications may lead to improper performance and compromise safety!"
6. Check controls periodically to verify they engage and disengage properly and adjust, if necessary. Refer to the adjustment section in this operator's manual for instructions.
7. Maintain or replace safety and instruction labels, as necessary.
8. Observe proper disposal laws and regulations for gas, oil, etc. to protect the environment.
9. Prior to storing, run machine a few minutes to clear snow from machine and prevent freeze up of auger/impeller.
10. Never store the machine or fuel container inside where there is an open flame, spark or pilot light such as a water heater, furnace, clothes dryer etc.
11. Always refer to the operator's manual for proper instructions on off-season storage.

YOUR RESPONSIBILITY

Restrict the use of this power machine to persons who read, understand and follow the warnings and instructions in this manual and on the machine.

Do not modify engine

To avoid serious injury or death, do not modify engine in any way. Tampering with the governor setting can lead to a runaway engine and cause it to operate at unsafe speeds. Never tamper with factory setting of engine governor.

Notice regarding Emissions

Engines which are certified to comply with California and federal EPA emission regulations for SORE (Small Off Road Equipment) are certified to operate on regular unleaded gasoline, and may include the following emission control systems: Engine Modification (EM) and Three Way Catalyst (TWC) if so equipped.

SAFETY LABELS FOUND ON YOUR SNOW THROWER

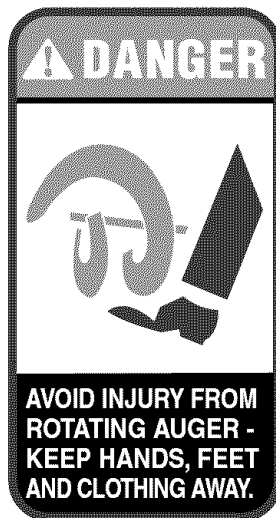
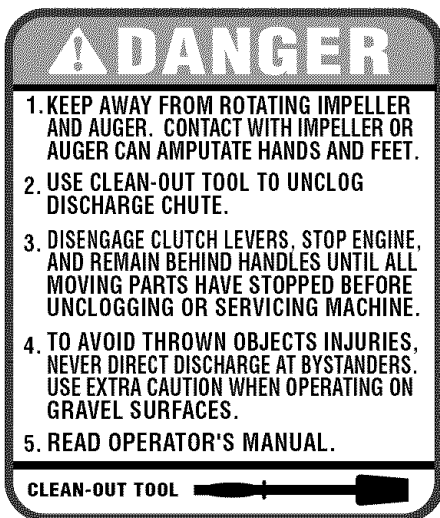

SECTION 2: ASSEMBLING YOUR SNOW THROWER

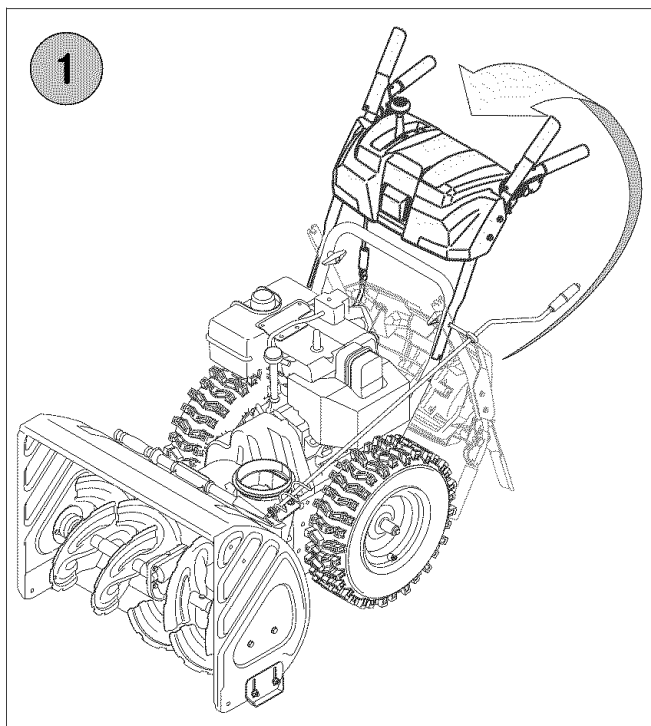

NOTE: References to right or left side of the snow thrower are determined from behind the unit in the operating position (standing directly behind the snow thrower, facing the handle panel).

IMPORTANT: Two replacement auger shear pins are included with this manual (or stowed in the plastic handle panel). Refer to **Augers** on page 19 for more information regarding shear pin replacement.



CAUTION: Prior to operating your snow thrower, refer to **Auger Control Test** on page 11. Read and follow all instructions carefully and perform all adjustments to verify your snow thrower is operating safely and properly.

1. Observe the lower rear area of the snow thrower to be sure both cables are aligned with roller guides before pivoting the handle upward.
2. Secure the upper shift rod to the lower shift rod by sliding the connector sleeve downward.
 - Secure the handle by tightening the plastic wing knob located on both the left and right sides of the handle. Remove and discard any rubber bands, if present. They are for packaging purposes only.
3. Apply a light lubricant (i.e. 3-in-1 oil) to the rim/lip of the chute base (and the underside of the chute assembly) and position the chute assembly over the base.
4. Close the flange keepers to secure the chute assembly to the chute base. The flange keepers will click into place when properly secure.

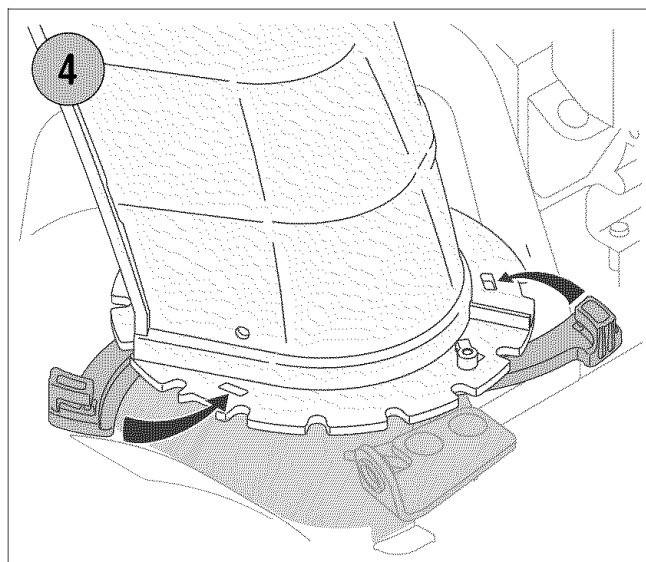
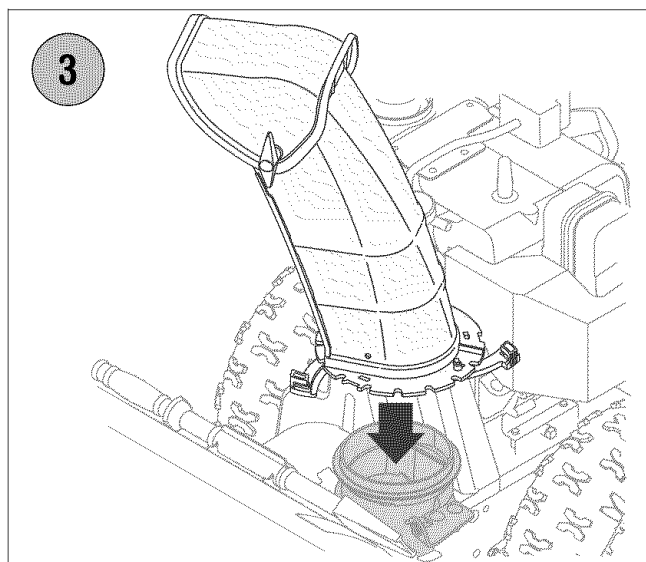
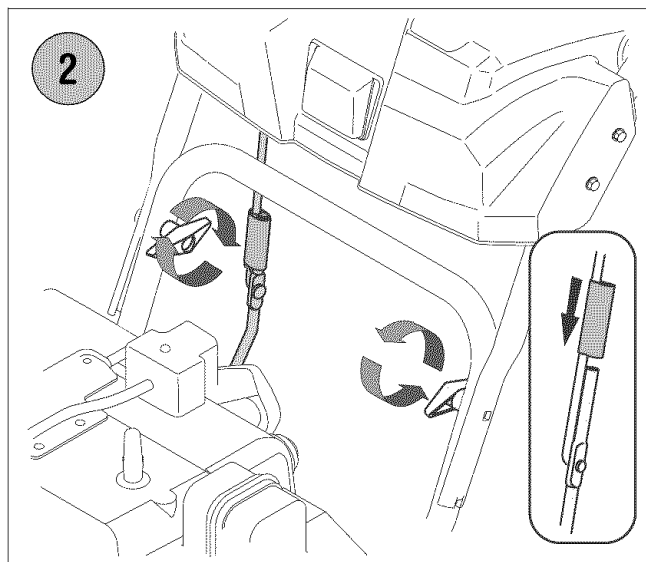

NOTE: If the flange keepers will not easily click into place, use the palm of your hand to apply swift, firm pressure to the back of each.

5. Remove the flat washer and hairpin clip from the end of the chute directional control. Insert the end of the chute directional control into the lower bracket and secure with the flat washer and hairpin clip just removed.

NOTE: If necessary, the lower bracket can be adjusted. Refer to **Chute Bracket Adjustment** on Page 14.



CAUTION: Prior to operating your snow thrower, refer to **Auger Control Test** on page 11. Read and follow all instructions carefully and perform all adjustments to verify your snow thrower is operating safely and properly.

Tire Pressure

- Before operating, check tire pressure and reduce pressure in both tires to between 15 psi and 20 psi.

NOTE: If the tire pressure is not equal in both tires, the unit may not travel in a straight path and the shave plate may wear unevenly.

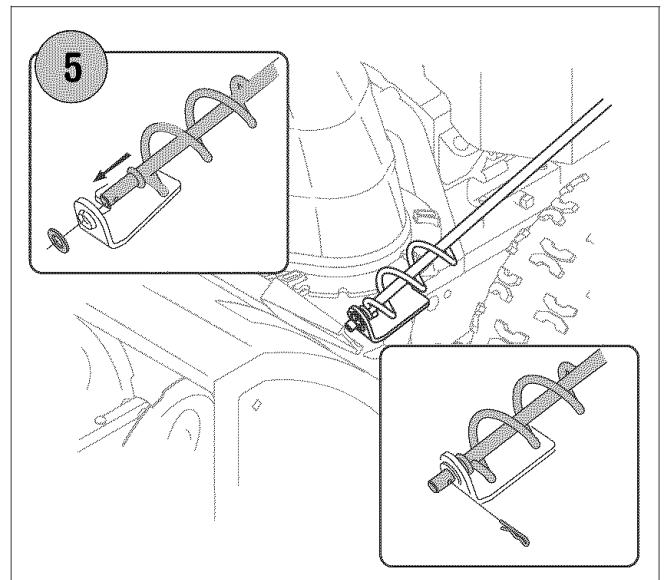

SECTION 3: KNOW YOUR SNOW THROWER

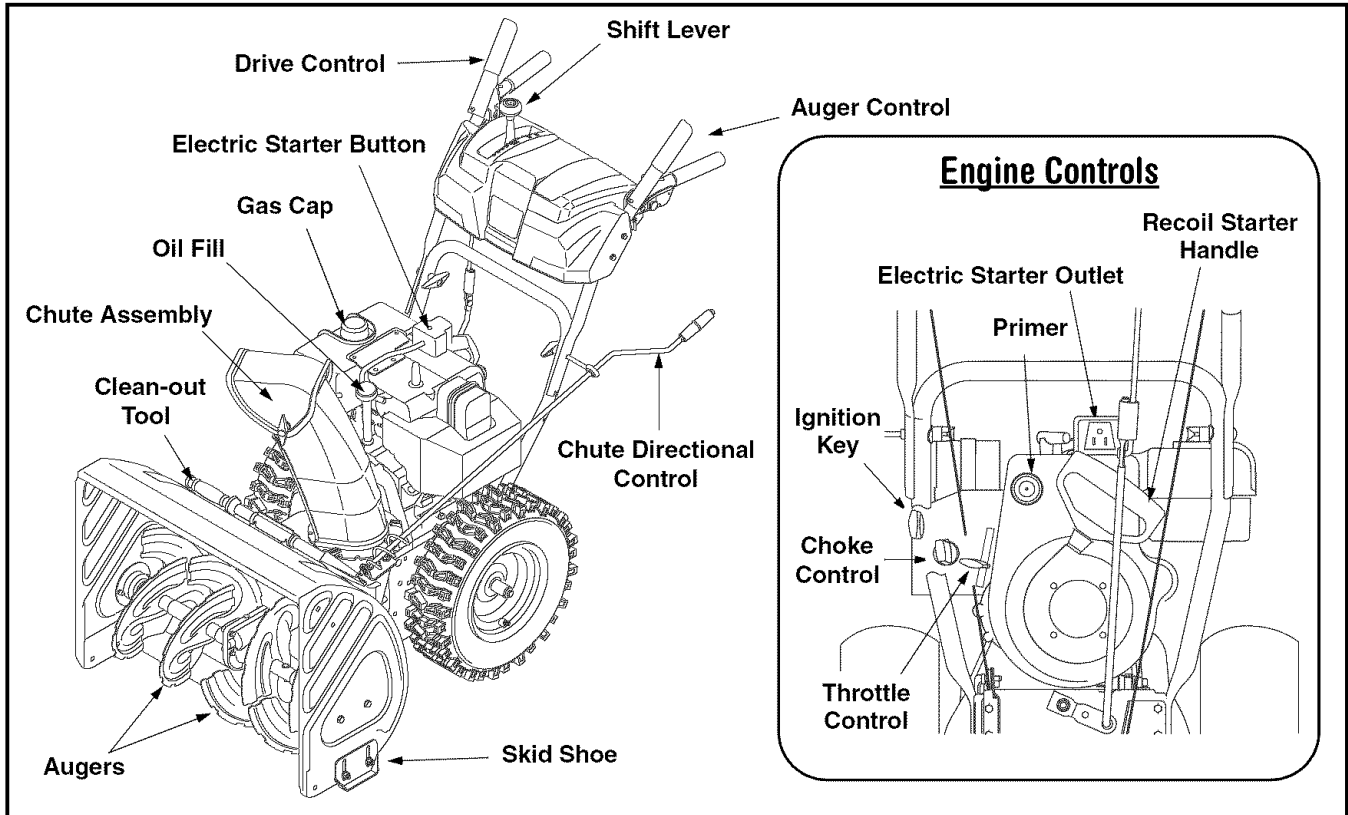

WARNING: Read, understand, and follow all instructions and warnings on the machine and in this manual before operating.

NOTE: For detailed starting instructions and more information on all engine controls, refer to the *Tecumseh Engines* manual packed separately and **Starting The Engine** on page 10 of this manual.

Shift Lever

The shift lever is located on the right side of the handle panel. Place the shift lever into any of eight positions to control the direction of travel and ground speed.

Forward

There are six forward (F) speeds. Position one (1) is the slowest and position six (6) is the fastest.

Reverse

There are two reverse (R) speeds. One (1) is the slower and two (2) is the faster.

Gas Cap

Unthread the gas cap to add gasoline to the fuel tank.

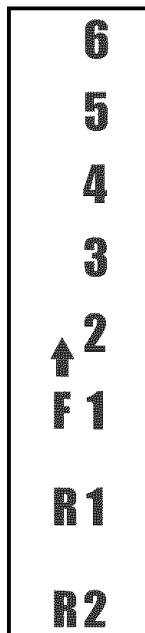

Choke Control

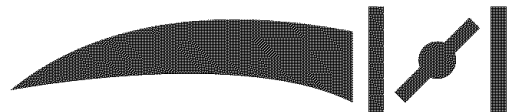

The choke control is found on the rear of the engine and is activated by rotating the knob clockwise. Activating the choke control closes the choke plate on the carburetor and aids in starting the engine.

Throttle Control

The throttle control is located on the engine. It regulates the speed of the engine and will shut off the engine when pushed down completely.

Primer

Depressing the primer forces fuel directly into the engine's carburetor to aid in cold-weather starting.

Oil Fill

Engine oil level can be checked and oil added through the oil fill.

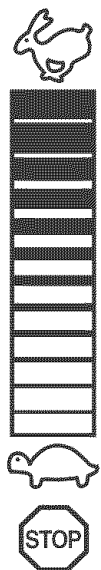

Auger Control

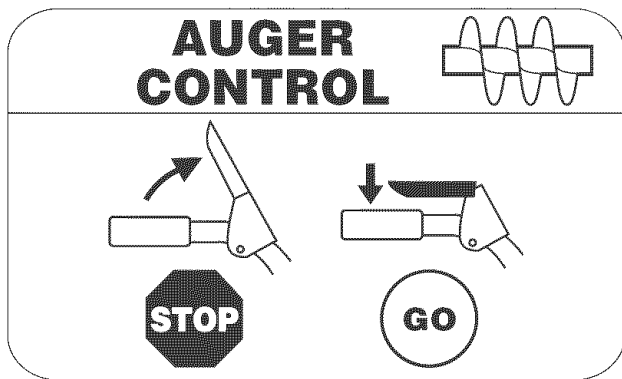

The auger control is located on the **left** handle. Squeeze the control grip against the handle to engage the augers and start snow throwing action. Release to stop.

Drive Control

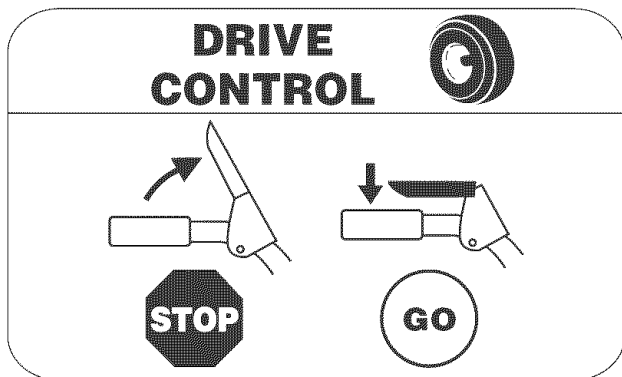

The drive control is located on the **right** handle. Squeeze the control grip against the handle to engage the wheel drive. Release to stop.

Chute Directional Control

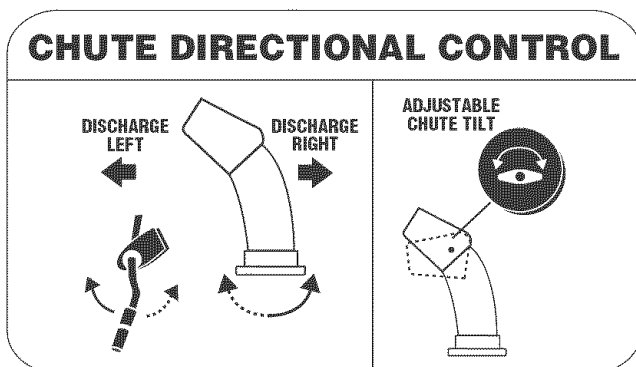

The chute directional control is located on left side of the snow thrower.

To change the direction in which snow is thrown, turn chute directional control as follows:

- Crank clockwise to discharge to the left.
- Crank counterclockwise to discharge to the right.

Ignition Key

The ignition key is a safety device. It must be **fully** inserted in order for the engine to start. Remove the ignition key when the snow thrower is not in use.

IMPORTANT: Do not turn the ignition key in an attempt to start the engine. Doing so may cause it to break.

Clean-Out Tool



WARNING: Never use your hands to clear a clogged chute assembly. Shut off engine and remain behind handles until all moving parts have stopped before unclogging.

The chute clean-out tool is fastened to the top of the auger housing with a mounting clip. The tool is designed to clear a clogged chute assembly. Refer to **Operating Your Snow Thrower** section for more detailed information regarding the chute clean-out tool.

NOTE: This item is fastened with a cable tie to the rear of the auger housing at the factory. Cut the cable tie before operating the snow thrower.

Skid Shoes

Position the skid shoes based on surface conditions. Adjust upward for hard-packed snow. Adjust downward when operating on gravel or crushed rock surfaces.

Recoil Starter Handle

This handle is used to manually start the engine.

Electric Starter Button

Pressing the electric starter button engages the engine's electric starter when plugged into a 120V power source.

Electric Starter Outlet

Requires the use of a three-prong outdoor extension cord and a 120V power source/wall outlet.

Augers

When engaged, the augers rotate and draw snow into the auger housing.

Chute Assembly

Snow drawn into the auger housing is discharged out the chute assembly.

Spark Plug Cover

Unscrew 1/4-turn to access the spark plug and spark plug wire.

SECTION 4: OPERATING YOUR SNOW THROWER

Before Starting



WARNING: Read, understand, and follow all instructions and warnings on the machine and in this manual before operating.

Gas & Oil Fill-Up

Service the engine with gasoline and oil as instructed in the *Tecumseh Engines* manual packed separately with your snow thrower. **Read instructions carefully.**



WARNING: Use extreme care when handling gasoline. Gasoline is extremely flammable and the vapors are explosive. Never fuel the machine indoors or while the engine is hot or running. Extinguish cigarettes, cigars, pipes and other sources of ignition.

- A small plastic cup may be located inside the fuel fill opening beneath the gas cap. Remove and discard this cup before filling up the tank.

Starting The Engine

- Attach spark plug wire to spark plug. Make certain the metal loop on the end of the spark plug wire (inside the rubber boot) is fastened securely over the metal tip on the spark plug.
- Make certain both the auger control and drive control are in the disengaged (released) position.
- Move throttle control up to FAST position. Insert ignition key into slot. Make sure it snaps into place. **Do not attempt to turn the key.**

NOTE: *The engine cannot start unless the key is inserted into ignition switch.*

Electric Starter

- Determine that your home's wiring is a three-wire grounded system. Ask a licensed electrician if you are not certain.



CAUTION: If your home's wiring system is not a three-wire grounded system, do not use this electric starter under any conditions.



WARNING: The optional electric starter is equipped with a grounded three-wire power cord and plug, and is designed to operate on 120 volt AC household current. It must be used with a properly grounded three-prong receptacle at all times to avoid the possibility of electric shock. Follow all instructions carefully prior to operating the electric starter.



WARNING: If your home electrical system is grounded, but a three-hole receptacle is not available, do not use your snow thrower's electric starter.

If you have a grounded three-prong receptacle, proceed as follows:

- Plug the extension cord into the outlet located on the engine's surface. Plug the other end of extension cord into a three-prong 120-volt, grounded, AC outlet in a well-ventilated area.
- Rotate choke control to FULL choke position (cold engine start).

NOTE: *If the engine is already warm, place choke control in the OFF position instead of FULL.*

- Push the primer two or three times for cold engine start, making sure to cover vent hole in the center of the primer when pushing.

NOTE: *DO NOT use primer to restart a warm engine after a short shutdown.*

- Push starter button to start engine.
- Once the engine starts, immediately release starter button.
- As the engine warms, slowly rotate the choke control to the OFF position. If the engine falters, quickly rotate the choke control back to FULL and then slowly into the OFF position again.
- When disconnecting the extension cord, always unplug the end at the three-prong wall outlet before unplugging the opposite end from the snow thrower.

Recoil Starter

- Rotate choke control to FULL choke position (cold engine start).

NOTE: *If the engine is already warm, place choke control in the OFF position instead of FULL.*

- Push the primer two or three times for cold engine start, making sure to cover vent hole in the center of the primer when pushing.

NOTE: *DO NOT use primer to restart a warm engine after a short shutdown.*

NOTE: *Additional priming may be necessary if the temperature is below 15° Fahrenheit.*

- Grasp the recoil starter handle and slowly pull the rope out. At the point where it becomes slightly harder to pull the rope, slowly allow the rope to recoil.

- Pull the starter handle with a firm, rapid stroke.

IMPORTANT: Do not release the handle and allow it to snap back. Keep a firm hold on the starter handle and allow it to slowly recoil.

- As the engine warms, slowly rotate the choke control to the OFF position. If the engine falters, quickly rotate the choke control back to the FULL position and then slowly into the OFF position again.

Stopping The Engine

- Run engine for a few minutes before stopping to help dry off any moisture on the engine.
- To help prevent possible starter freeze-up, proceed as follows:

Electric Starter (on models so equipped)

1. Connect extension cord to the electric starter outlet on the engine, then to 120 volt AC outlet.
2. With the engine running, push the starter button and allow the starter for spin for several seconds. The noise made by the starter is normal. The engine's starter is not being harmed.
3. When disconnecting the extension cord, always unplug the end at the three-prong wall outlet before unplugging the opposite end from the snow thrower.
4. Move throttle control to STOP position.
5. Remove the ignition key.
6. Wipe all snow and moisture from the area around the engine as well as the area in and around the drive control and auger control. Also, engage and release both controls several times.

NOTE: *Keep the key in a safe place. The engine cannot start without the ignition key.*

Recoil Starter

1. With engine running, pull starter rope with a rapid, continuous full arm stroke three or four times. Pulling the starter rope will produce a loud clattering sound, which is not harmful to engine.
2. Move throttle control to STOP position.
3. Remove the ignition key.

NOTE: *Keep the key in a safe place. The engine cannot start without the ignition key.*

4. Wipe all snow and moisture from the area around the engine as well as the area in and around the drive control and auger control. Also, engage and release both controls several times.

To Engage Drive

- With the throttle control in the Fast (rabbit) position, move shift lever into one of the six forward (F) positions or two reverse (R) positions. Select a speed appropriate for the snow conditions and a pace you're comfortable with.

IMPORTANT: Use the slower speeds until you are comfortable and familiar with the operation of the snow thrower.

- Squeeze the auger control against the handle and the augers will turn. Release it and the augers will stop.
- Squeeze the drive control against the handle the snow thrower will move. Release it and drive motion will stop.

IMPORTANT: NEVER reposition the shift lever (change speeds or direction of travel) without first releasing the drive control and bringing the snow thrower to a complete stop. Doing so will result in premature wear to the snow thrower's drive system.

To Engage Augers

- To engage the augers and start throwing snow, squeeze the auger control against the left handle. Release to stop the augers.

Auger Control Test

IMPORTANT: Perform the following test before operating your snow thrower for the first time and at the start of each winter season.

Check the adjustment of the auger control as follows:

- When the auger control is released and in the disengaged "up" position, the cable should have very little slack. It should NOT be tight.
- In a well-ventilated area, start the snow thrower engine as instructed earlier in this section under the heading **Starting the Engine**. Make sure the throttle is set in the FAST position.
- While standing in the operator's position (behind the snow thrower), engage the auger.
- Allow the auger to remain engaged for approximately ten (10) seconds before releasing the auger control. Repeat this several times.
- With the throttle control in the FAST (rabbit) position and the auger control in the disengaged "up" position, walk to the front of the machine.
- Confirm that the auger has completely stopped rotating and shows NO signs of motion.

IMPORTANT: If the auger shows ANY signs of rotating, immediately return to the operator's position and shut off the engine. Wait for ALL moving parts to stop before re-adjusting the auger control.

- To readjust the control cable, loosen the hex jam nut on the auger control cable “Z” fitting.
- Rotate the coupling end of the cable counterclockwise to provide more slack.
- Retighten the hex jam nut. See Figure 1.
- Repeat Auger Control Test to verify proper adjustment has been achieved.

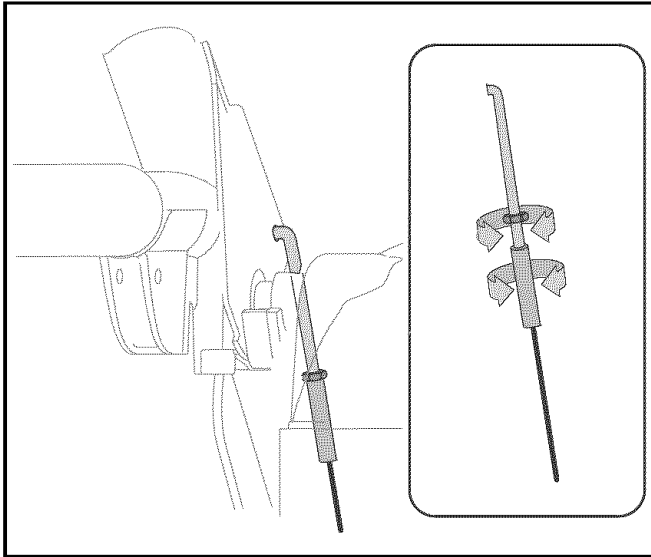

Figure 1

Chute Clean-Out Tool

The chute clean-out tool is conveniently fastened to the rear of the auger housing with a mounting clip. Should snow and ice become lodged in the chute assembly during operation, proceed as follows to safely clean the chute assembly and chute opening:

- Release both the Auger Control and the Drive Control.
- Stop the engine by removing the ignition key.

- Remove the clean-out tool from the clip which secures it to the rear of the auger housing.
- Use the shovel-shaped end of the clean-out tool to dislodge and scoop any snow and ice which has formed in and near the chute assembly.



WARNING: Never use your hands to clean snow and ice from the chute assembly or auger housing

- Refasten the clean-out tool to the mounting clip on the rear of the auger housing, reinsert the ignition key and start the snow thrower's engine.
- While standing in the operator's position (behind the snow thrower), engage the auger control for a few seconds to clear any remaining snow and ice from the chute assembly.

Operating Tips

NOTE: Allow the engine to warm up for a few minutes after starting. The engine will not develop full power until it reaches operating temperature.



WARNING: The muffler, engine and surrounding areas become hot and can cause a burn. Do not touch.

- Discharge snow downwind whenever possible.
- Slightly overlap each previous swath.
- Set the skid shoes 1/4" below the scraper bar for normal usage. The skid shoes may be adjusted upward for hard-packed snow. Adjust downward when using on gravel or crushed rock.
- Avoid possible starter freeze-up. Clean the snow thrower thoroughly after each use.

SECTION 5: MAKING ADJUSTMENTS



WARNING: Never attempt to make any adjustments while the engine is running, except where specified in operator's manual.

Shift Rod Adjustment

If the full range of speeds (forward and reverse) cannot be achieved, refer to the figures to the right and adjust the shift rod as follows:

1. Place the shift lever in the fastest forward speed position and remove the hairpin clip which secures the ferrule to the shift lever.
2. Rotate the shift arm clockwise as far as it will go.
3. Thread the ferrule up or down the shift rod until it aligns with the hole in the shift lever. Resecure the ferrule with the hairpin clip removed earlier.

Tire Pressure

- Before operating, check tire pressure and reduce pressure to between 15 psi and 20 psi.

NOTE: If the tire pressure is not equal in both tires, the unit may pull to one side or the other.

Chute Assembly

The distance snow is thrown can be adjusted by changing the angle of the chute assembly. To do so, stop the engine by removing the ignition key and loosen the plastic wing knob found on the left side of the chute assembly. Pivot the chute upward or downward before re-tightening the wing knob. See Figure 2.

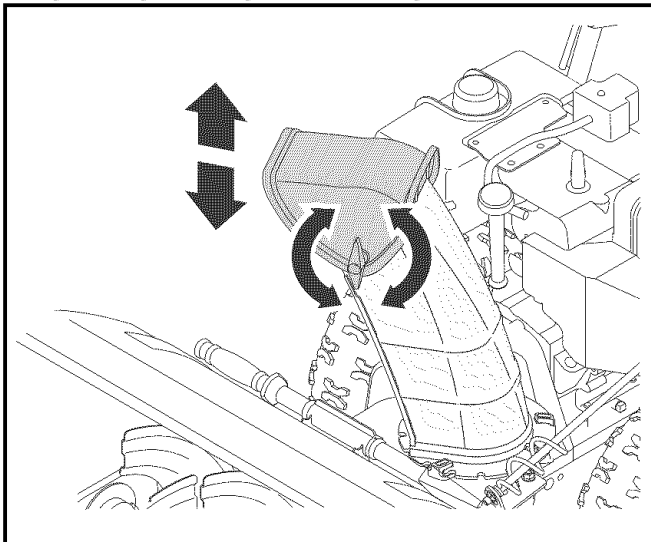
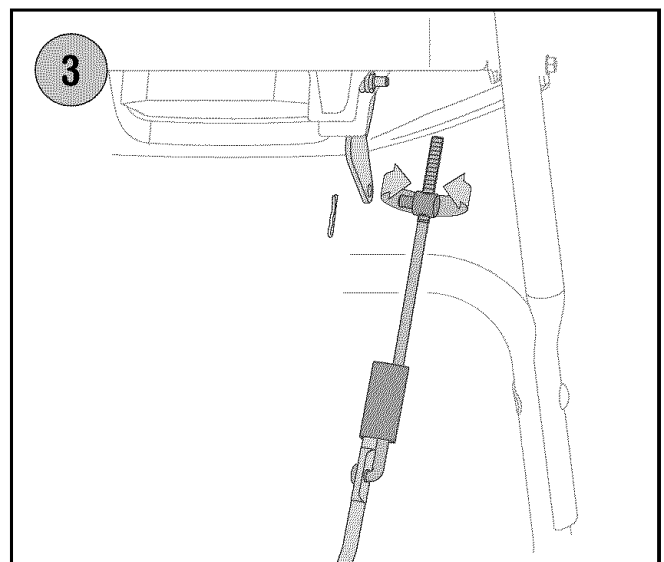
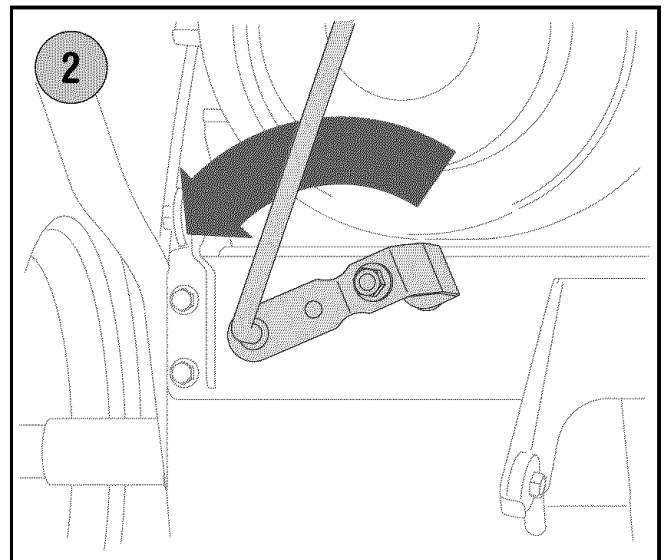
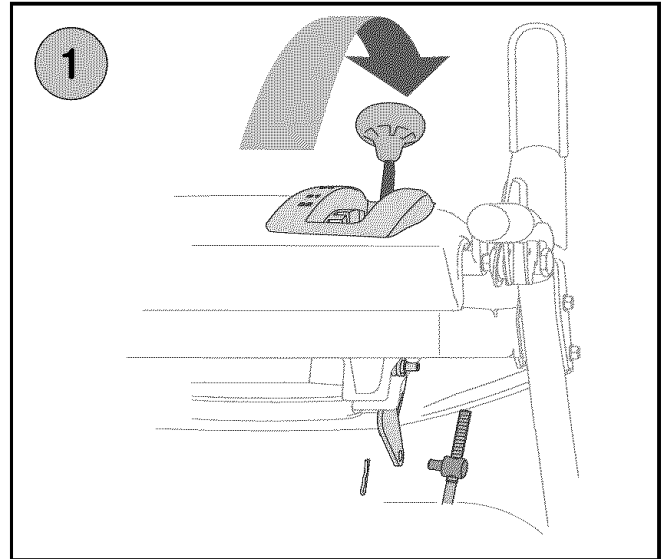

Figure 2



Drive Control

When the drive control is released and in the disengaged “up” position, the cable should have very little slack. It should NOT be tight.

Check the adjustment of the drive control as follows:

1. With the drive control released, push the snow thrower gently forward. The unit should roll freely.
2. Engage the drive control and gently attempt to push the snow thrower forward. The wheels should not turn. The unit should **not** roll freely.
3. With the drive control released, move the shift lever back and forth between the R2 position and the F6 position several times. There should be **no** resistance in the shift lever.

If any of the above tests failed, the drive cable is in need of adjustment. refer to the figure at the right and proceed as follows:

- Loosen the hex jam nut on the auger control cable “Z” fitting and rotate the coupling end of the cable downward to provide more slack or upward to take up slack. See Figure 3.
- Retighten the hex jam nut and repeat all three tests to verify proper adjustment has been achieved.

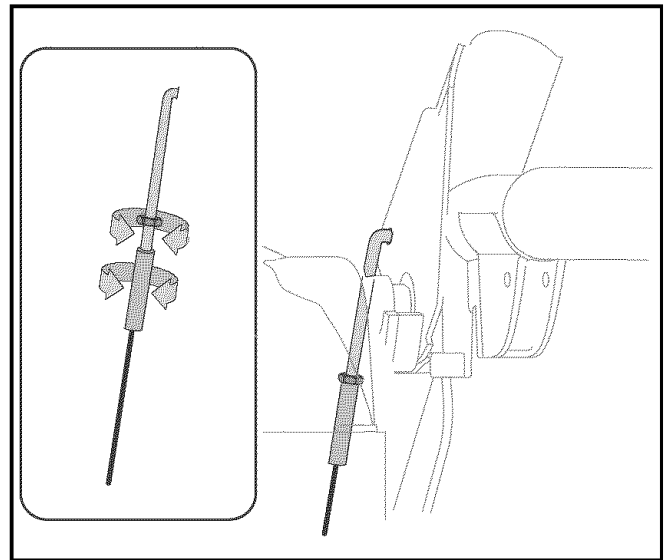

Figure 3

Auger Control

Refer to **Auger Control Test** on Page 11 to adjust the auger control.

Skid Shoes

The space between the skid shoes and the ground can be adjusted. See Figure 4.

- For close snow removal on a smooth surface, raise skid shoes higher on the auger housing.
- Use a middle or lower position when the area to be cleared is uneven, such as a gravel driveway.

 **CAUTION:** Loose gravel can be picked up and thrown by the auger, causing injury to the operator and bystanders and/or damage to the snow thrower and surrounding property.

- Adjust skid shoes by loosening the four hex nuts (two on each side) and carriage bolts. Move skid shoes to desired position.
- Make certain the entire bottom surface of skid shoe is against the ground to avoid uneven wear on the skid shoes. Retighten nuts and bolts securely.

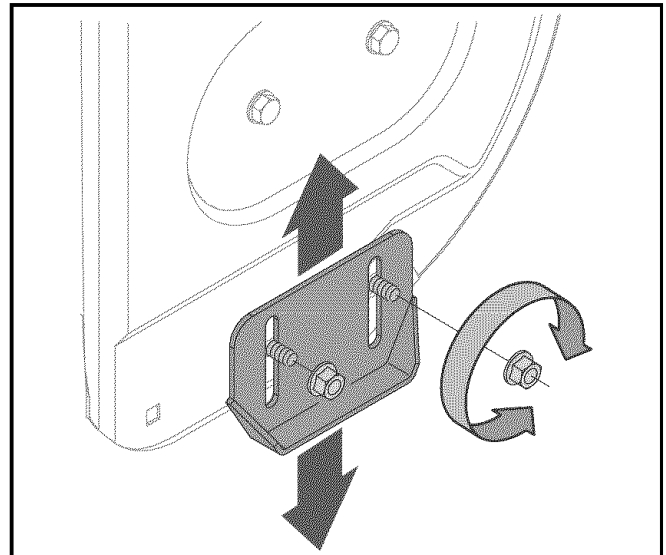

Figure 4

Chute Bracket Adjustment

If the spiral at the bottom of the chute directional control is not fully engaging with the chute assembly, the chute bracket can be adjusted. To do so, loosen the two nuts which secure the chute bracket and reposition it slightly before retightening the nuts. See Figure 5.

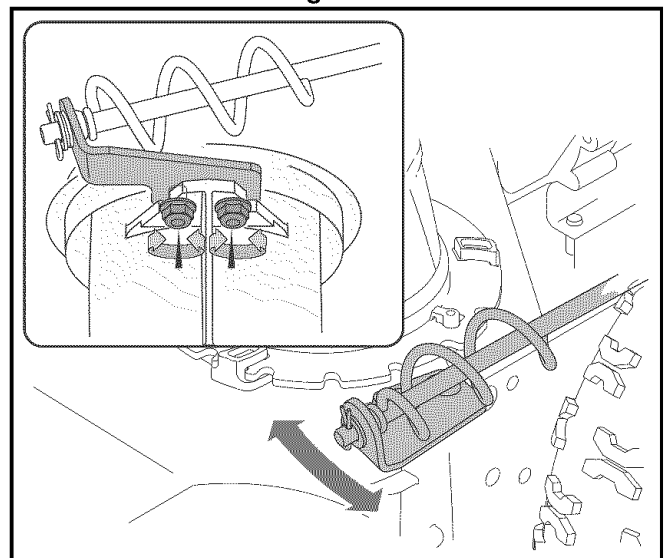

Figure 5

SECTION 6: MAINTAINING AND SERVICING YOUR SNOW THROWER



WARNING: Before lubricating, repairing, or inspecting, disengage all controls and stop engine. Wait until all moving parts have come to a complete stop.

Engine

Refer to the separate *Tecumseh Engines* manual packed with your unit for all engine maintenance.

Lubrication

Engine

Refer to the separate *Tecumseh Engines* manual packed with your unit for all engine lubrication instructions.

Gear Shaft

The gear (hex) shaft should be lubricated at least once a season or after every 25 hours of operation.

- Remove the lower frame cover by removing the two screws which secure it.
- Apply a light coating of an all-weather multi-purpose grease to the hex shaft. See Figure 6.

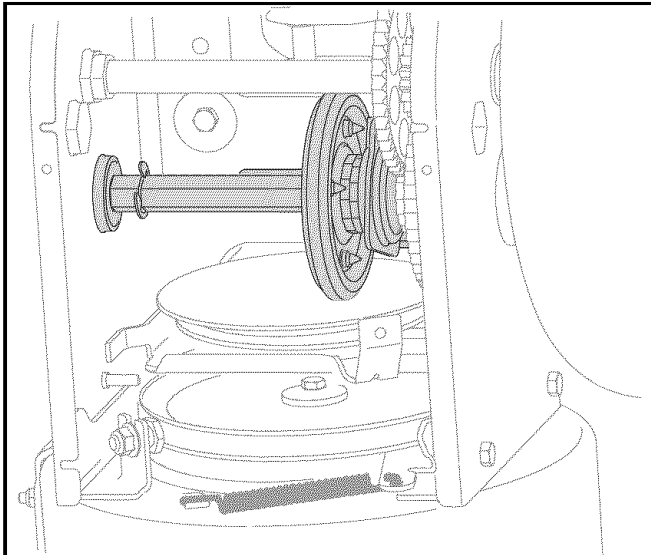

Figure 6

IMPORTANT: Keep lubricant off the friction wheel and drive plate.

Wheels

- At least once a season, remove both wheels. Clean and coat the axles with a multipurpose automotive grease before reinstalling wheels.

Chute Directional Control

- Once a season, the joystick should be lubricated with petroleum jelly, linseed oil, mineral oil, paraffin wax or 3-in-1 oil.

Auger Shaft

- At least once a season, remove the shear pins on auger shaft. Spray lubricant inside shaft, around the spacers. Also lubricate the flange bearings found at either end of the shaft. See Figure 7.

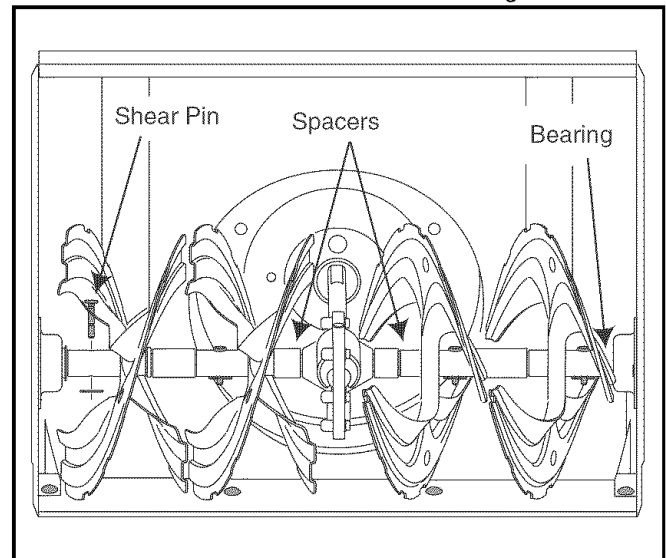

Figure 7

Gear Case

The auger gear case has been filled with grease at the factory. If disassembled for any reason, lubricate with two ounces of grease (Part Number 737-0168).

IMPORTANT: Do not overfill the gear case. Damage to the seals could result. Be sure the vent plug is free of grease in order to relieve pressure.



WARNING: Before servicing, repairing, or inspecting, disengage all controls and stop engine. Wait until all moving parts have come to a complete stop.

Shave Plate and Skid Shoes

- The shave plate and skid shoes on the bottom of the snow thrower are subject to wear. They should be checked periodically and replaced when necessary.
- To remove skid shoes, remove the four carriage bolts and hex flange nuts which secure them to the snow thrower. Reassemble new skid shoes with the four carriage bolts (two on each side) and hex flange nuts. Refer to Figure 4.
- To remove shave plate, remove the carriage bolts and hex nuts which attach it to the snow thrower housing. Reassemble new shave plate, making sure heads of carriage bolts are to the inside of housing. Tighten securely.

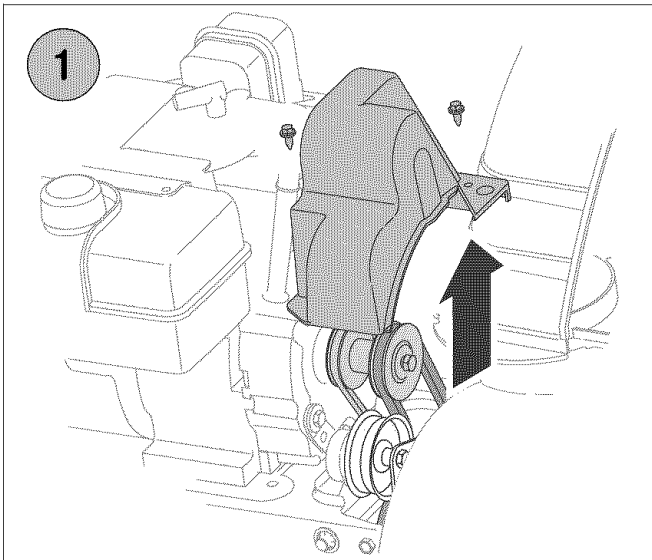

Auger Belt Replacement

To remove and replace your snow thrower's auger belt, proceed as follows:

1. Remove the plastic belt cover on the front of the engine by removing the two self-tapping screws.
 - Drain the gasoline from the snow thrower, or place a piece of plastic under the gas cap.
 - Carefully pivot the snow thrower up and forward so that it rests on the auger housing.
2. Remove the frame cover from the underside of the snow thrower by removing four self-tapping screws which secure it.
3. Roll the auger belt off the engine pulley.
4. Unhook the support bracket spring from the frame.
 - Loosen and remove the shoulder screw which acts as a belt keeper.
 - Remove the belt from around the auger pulley, and slip the belt between the support bracket and the auger pulley
 - Reassemble auger belt by following instructions in reverse order.

IMPORTANT: Do NOT forget to reinstall the shoulder screw and reconnect the spring to the frame after installing a replacement auger belt.

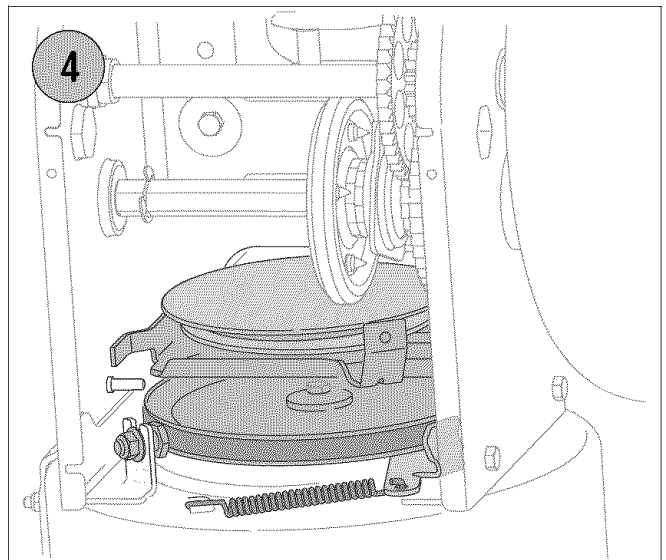
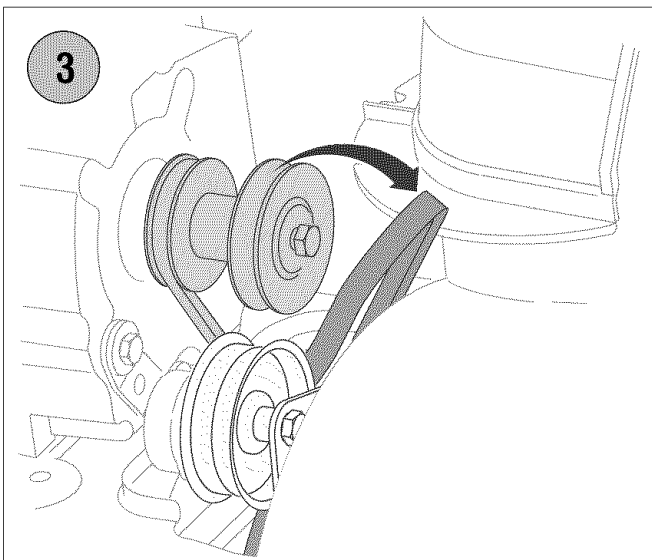
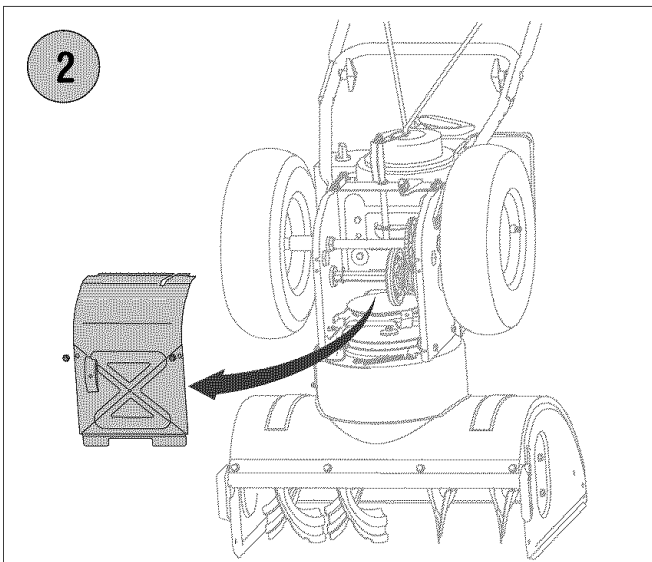

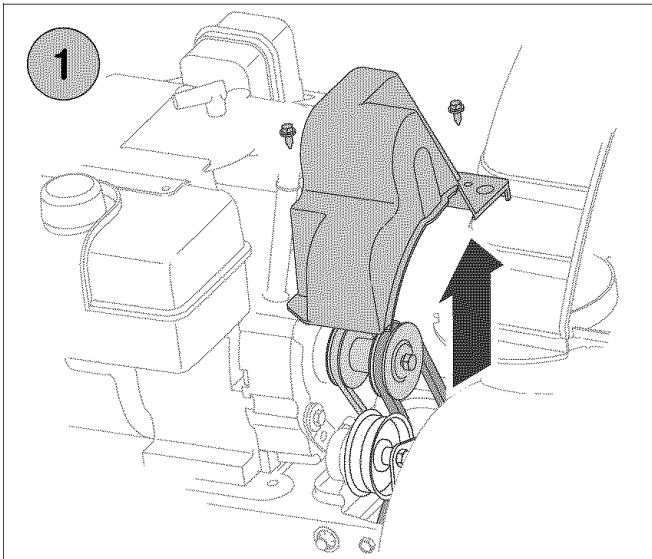

Drive Belt Replacement

To remove and replace your snow thrower's auger belt, proceed as follows:

1. Remove the plastic belt cover on the front of the engine by removing the two self-tapping screws.
 - Drain the gasoline from the snow thrower, or place a piece of plastic under the gas cap.
 - Carefully pivot the snow thrower up and forward so that it rests on the auger housing.
2. Remove the frame cover from the underside of the snow thrower by removing four self-tapping screws which secure it.
3.
 - a. Grasp the idler pulley and pivot it toward the right.
 - b. Insert a screw driver through aligning holes in both the idler bracket and the engine.
 - c. Roll the auger belt off the engine pulley.
 - d. Lift the drive belt off engine pulley.
4. Slip the drive belt off the pulley and between friction wheel and friction wheel disc.
 - Remove and replace belt in the reverse order.

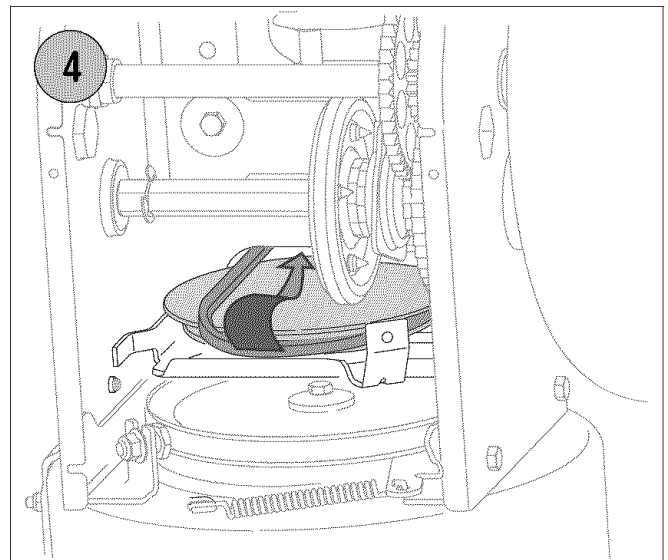
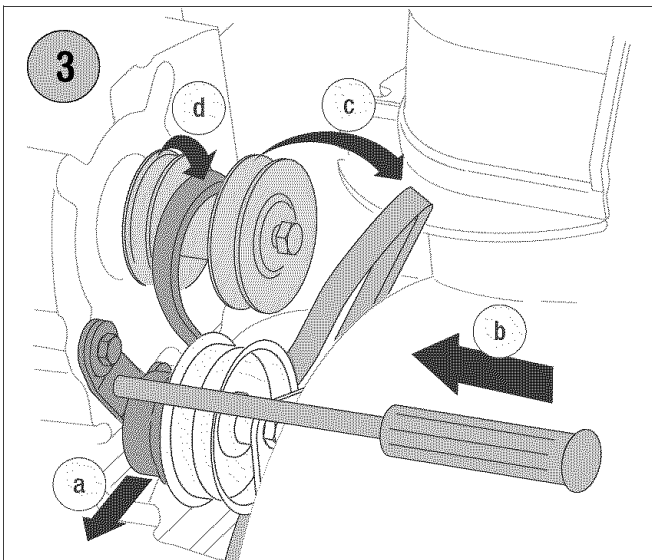
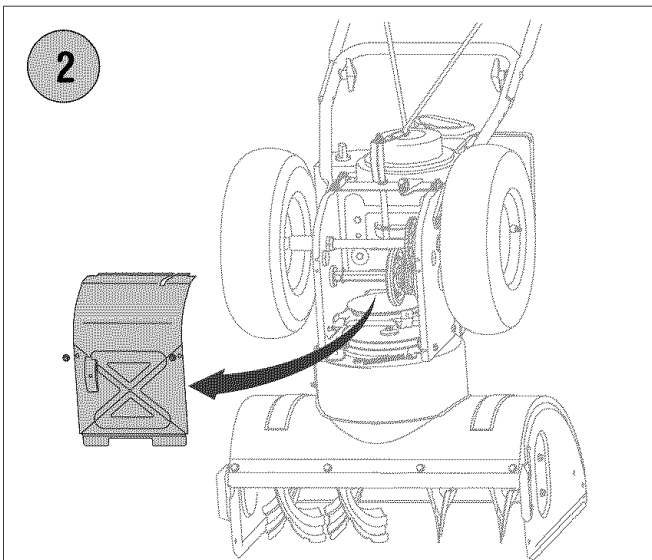

Friction Wheel Removal

If the snow thrower fails to drive with the drive control engaged, and performing the drive control cable adjustment on page 14 fails to correct the problem, the friction wheel may need to be replaced. Follow the instructions below. Examine the friction wheel for signs of wear or cracking and replace if necessary

- Place the shift lever in third Forward (F3) position.
 - Drain the gasoline from the snow thrower, or place a piece of plastic under the gas cap.
 - Carefully pivot the snow thrower up and forward so that it rests on the auger housing.
1. a. Remove the frame cover from the underside of the snow thrower by removing four self-tapping screws which secure it.
b. Remove the right-hand wheel by removing the screw and bell washer which secure it to the axle.
c. Locate the hex shaft and E-ring on the right side of the snow thrower frame, about two inches from the wheel axle.
c. Using a suitable tool, carefully remove the outer E-ring which secures the hex shaft to the snow thrower frame and lightly tap the shaft's end to dislodge the ball bearing from the right side of the frame.
 2. a. Slide the hex shaft downward and to the left while carefully un-meshing the lower gears on the hex shaft from the upper gears on the wheel axle.
b. Set the hex shaft's gears aside.
c. Carefully remove the inner E-ring from the hex shaft and slide the friction wheel assembly off the hex shaft.

NOTE: If you're replacing the friction wheel assembly as a whole, discard the worn part and slide the new part onto the hex shaft. Follow the steps above in reverse order to reassemble components. If you're disassembling the friction wheel and replacing only the rubber ring, proceed as follows:

3. Remove the four screws which secure the friction wheel's side plates together.
- Remove the rubber ring from between the plates.
 - Reassemble the side plates with a replacement rubber ring.

IMPORTANT: Tighten each screw only one rotation before turning the wheel clockwise and proceeding with the next screw. Repeat this process several times to ensure the plates are secured with equal force.

- Slide the friction wheel assembly back onto the hex shaft and follow the steps above in reverse order to reassemble components.

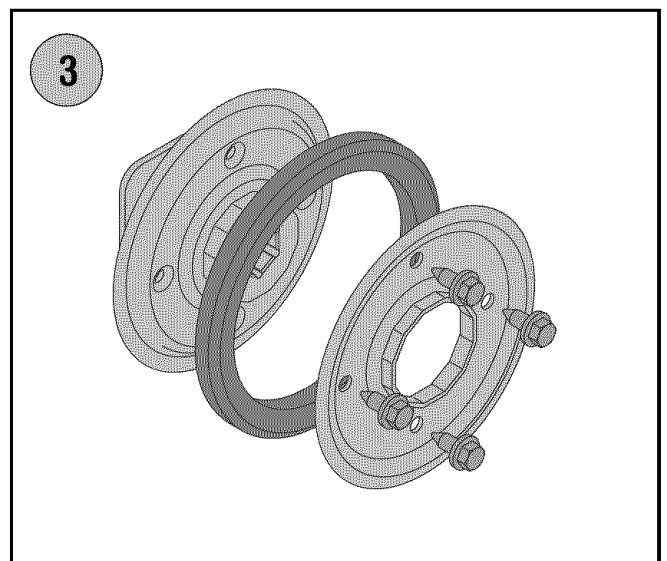
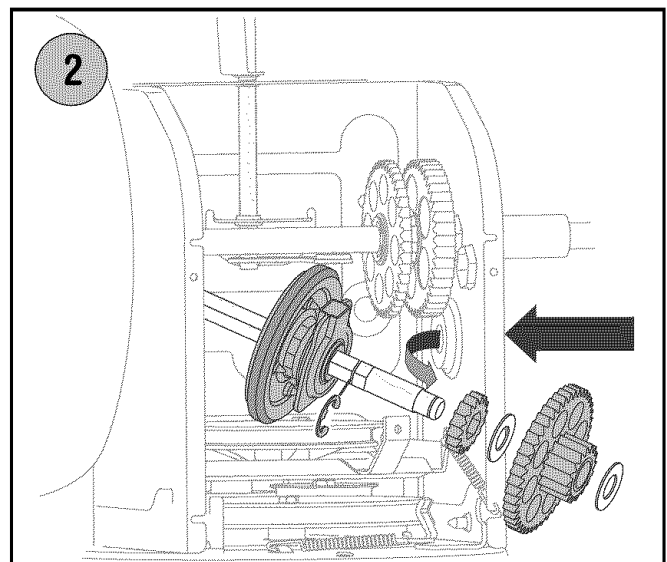
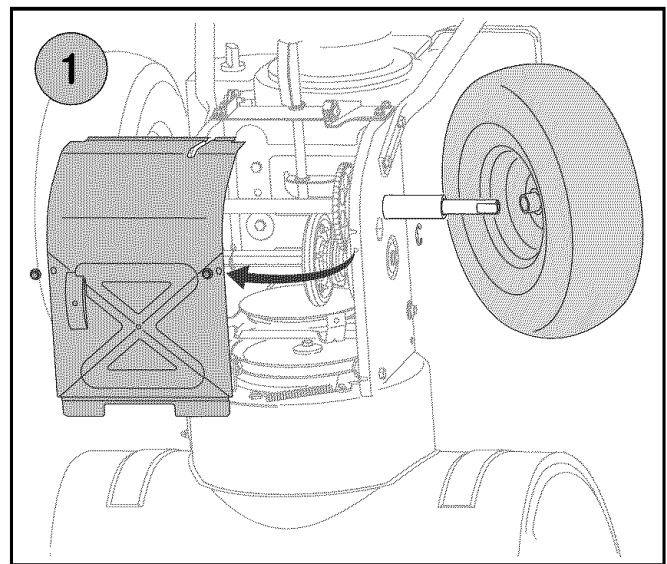

Augers

- The augers are secured to the spiral shaft with two shear pins and cotter pins. If the auger should strike a foreign object or ice jam, the snow thrower is designed so that the pins may shear. Refer to Figure 7.
- If the augers will not turn, check to see if the pins have sheared. One set of replacement shear pins has been provided with the snow thrower. When replacing pins, spray an oil lubricant into shaft before inserting new pins.

IMPORTANT: NEVER replace the auger shear pins with anything other than OEM Part No.738-04124 replacement shear pins. Any damage to the auger gearbox or other components as a result of failing to do so will NOT be covered by your snow thrower's warranty.

SECTION 7: OFF-SEASON STORAGE



WARNING: Never store the machine or fuel container indoors where there is an open flame, spark or pilot light such as on a water heater, furnace, clothes dryer or other gas appliances.



WARNING: Drain fuel into an approved container outdoors, away from open flame. Allow engine to cool. Extinguish cigarettes, cigars, pipes, and other sources of ignition prior to draining fuel. Fuel left in engine for extended period deteriorates and will cause serious starting problems.

If unit is to be stored over 30 days, prepare for storage as follows:

- Remove gasoline from carburetor and fuel tank to prevent gum deposits from forming on these parts and causing possible malfunction of engine.
- Run engine until fuel tank is empty and engine stops due to lack of fuel.

- Drain carburetor by pressing upward on bowl drain, located below the carburetor cover.

NOTE: *Fuel stabilizers, such as STA-BIL®, are an acceptable alternative in minimizing the formation of fuel gum deposits during storage. Do not drain carburetor if using a fuel stabilizer.*

- Wipe equipment with an oiled rag to prevent rust.
- Remove spark plug and pour one ounce of engine oil through spark plug hole into cylinder. Cover spark plug hole with rag. Crank engine several times to distribute oil. Replace spark plug.
- Follow the lubrication recommendations found in the Maintenance Section.
- Always store the snow thrower in a clean, dry area.

When storing any type of power equipment in an unventilated or metal storage shed, care should be taken to rust proof the equipment. Using a light oil or silicone, coat the equipment, especially any chains, springs, bearings and cables.

SECTION 8: TROUBLE SHOOTING GUIDE

Trouble	Possible Cause(s)	Corrective Action
Engine fails to start	Fuel tank empty, or stale fuel. Blocked fuel line. Choke control not in ON position Faulty spark plug. Ignition key not present. Spark plug wire disconnected. Engine not primed.	Fill tank with clean, fresh gasoline. Fuel will not last over thirty days unless a fuel stabilizer is used. Clean fuel line. Move choke control to ON position Clean, adjust gap or replace. Insert key into ignition switch. Connect spark plug wire. Refer to the <i>Tecumseh</i> engine manual or Starting the Engine on page 10 of this manual for instructions on the engine primer.
Engine runs erratic	Unit running on CHOKE. Blocked fuel line or stale fuel. Water or dirt in fuel system. Carburetor out of adjustment.	Move choke control to OFF position. Clean fuel line; fill tank with clean fresh gasoline. Fuel will not last over thirty days unless a fuel stabilizer is used. Drain fuel tank. Refill with fresh fuel. Refer to the <i>Tecumseh</i> engine manual.
Loss of power	Spark plug wire loose. Gas cap vent hole plugged. Exhaust port plugged.	Connect and tighten spark plug wire. Remove ice and snow from cap. Be certain vent hole is clear. Clean following the engine manual.
Engine overheats	Carburetor not adjusted properly.	Refer to the <i>Tecumseh</i> engine manual packed with your unit or have carburetor adjusted by an authorized service dealer.
Excessive vibration	Loose parts or damaged auger.	Stop engine immediately and disconnect spark plug wire. Tighten all bolts and nuts. Make all necessary repairs. If vibration continues, have unit serviced by an authorized service dealer.
Unit fails to propel itself	Incorrect adjustment of drive control cable. Drive belt loose or damaged.	Adjust drive control cable. Replace drive belt.
Unit fails to discharge snow	Chute assembly clogged. Foreign object lodged in auger. Incorrect adjustment of auger control cable. Drive belt loose or damaged.	Stop engine immediately. Clean chute assembly and inside of auger housing with chute clean-out tool Stop engine immediately. Remove object from auger. Adjust auger control cable. Replace drive belt.

NOTE: For repairs beyond the minor adjustments above, contact your local authorized service dealer.

NOTES

SECTION 9: PARTS LIST

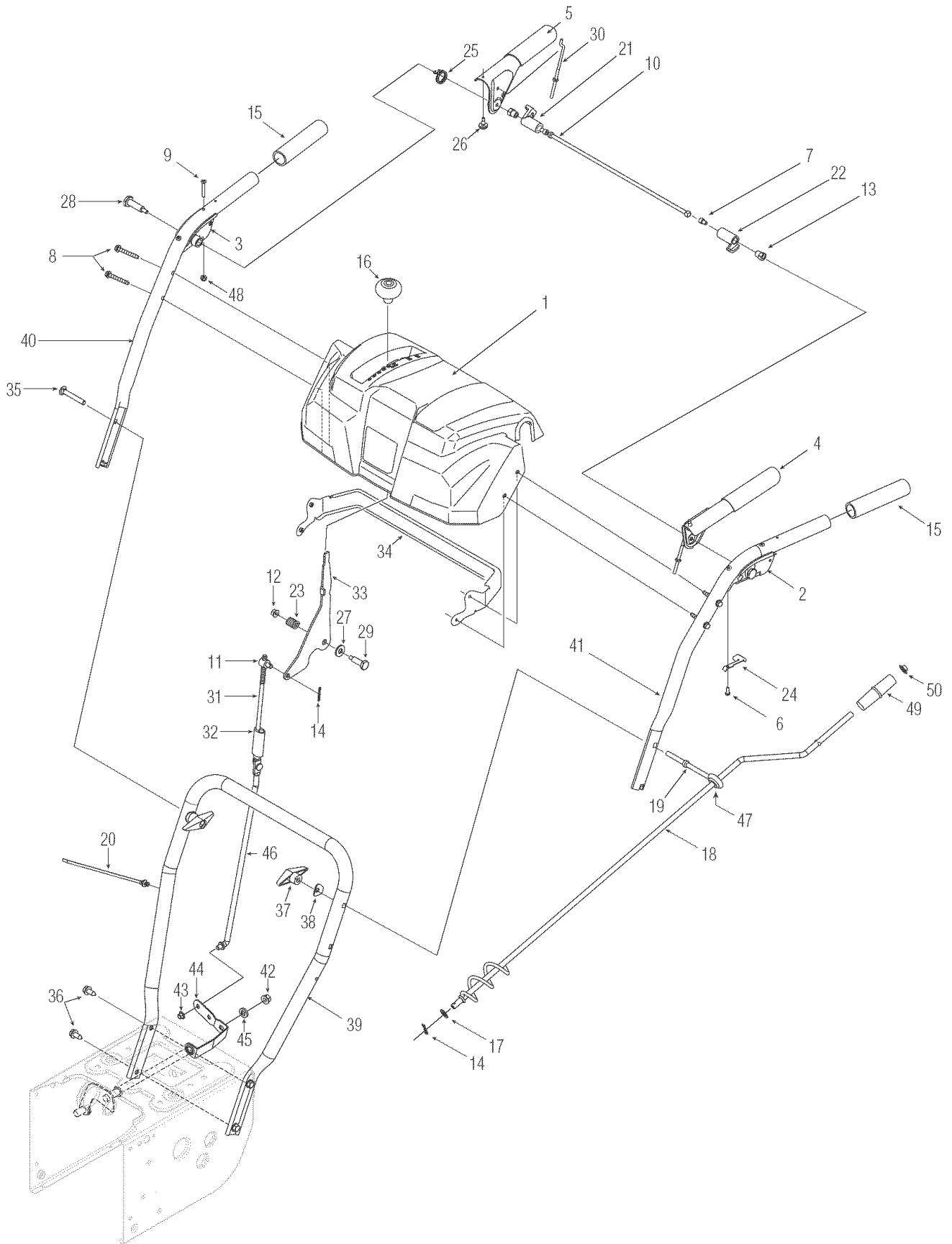

Style N

REF. NO.	PART NO.	DESCRIPTION
1	731-04872	Panel Assembly, Handle, N-Style
2	631-04133	Handle Assembly, Clutch Lock, LH (Inc. Ref. 48)
3	631-04134	Handle Assembly, Clutch Lock, RH (Inc. Ref. 48)
4	684-04105	Handle Assembly, Engagement, LH
5	684-04106	Handle Assembly, Engagement, RH
6	710-04326	Screw, #8-16 x .50
7	710-04354	Screw, 1/4-20 x .375
8	710-1026	Screw, Self-tapping, 1/4-20 x 1.750
9	710-1233	Screw, Machine, #10-24 x 1.375
10	711-04287	Rod, Pivot
11	711-0677	Ferrule, 5/16-18 x .312
12	712-04064	Nut, Flange Lock, Nylon, 1/4-20
13	712-04081A	Nut, Shoulder, Hex, 1/4-20,
14	714-0104	Pin, Cotter, .072 Dia. x 1.13
15	720-0274	Grip, 1.0 ID x 5.0
16	720-04039	Knob, Shift
17	736-0185	Washer, Flat, .375 x .738 x .063
18	684-04104	Crank Assembly, Chute
19	747-04263	Eye Bolt, Chute Crank
20	726-0470	Tie, Cable, 19 x 8.39", Tree Mount
21	731-04894	Plate, Lock
22	731-04896	Cam, Clutch Lock
23	732-0193	Spring, Compression, .39 x .60 x .88
24	732-04219	Spring, Clutch, Lock
25	732-04238	Spring, Torsion, 0.8156 ID x .3038
26	735-0199A	Bumper, Rubber, .62 OD x .22
27	736-0262	Washer, Flat, .385 x .870 x .092
28	738-04122	Screw, Shoulder, .437 x 1.345, 1/4-20
29	738-04125	Screw, Shoulder, .374 Dia. x 1.05
30	746-0778	Z-Fitting, Cable
31	747-04284	Rod, Shift, .312 x 9.0 Upper
32	750-04314	Connector Sleeve, Shift Rod
33	790-00130	Lever, Shift
34	790-00140	Bracket, Panel
35	710-0449	Screw, Carriage, 5/16-18, 2.25, Gr5
36	710-0726	Screw, 5/16-12, 0.750
37	720-0284	Wing Knob, 5/16-18
38	736-0451	Washer, Saddle, 320 x .93 x .060
39	749-04138	Handle, Lower, Snow
40	749-04141	Handle, Upper, RH
41	749-04142	Handle, Upper, LH
42	712-04063	Nut, Flange Lock, Nylon, 5/16-18
43	726-0135	Nut, Speed, .3125 Dia.
44	732-04205	Spring Lever, Shift
45	736-3015	Washer, Flat, .469 x .875 x .105
46	747-04257	Shift Rod, Lower
47	735-0234	Grommet, .44 ID x .94 OD x .50
48	712-0161	Nut, Hex Lock, Nylon, #10-24, Gr2
49	720-0201A	Crank Knob, 1.0 Diameter x 3.2, Black
50	726-0100	Cap, Push, 3/8 Rod

Style N

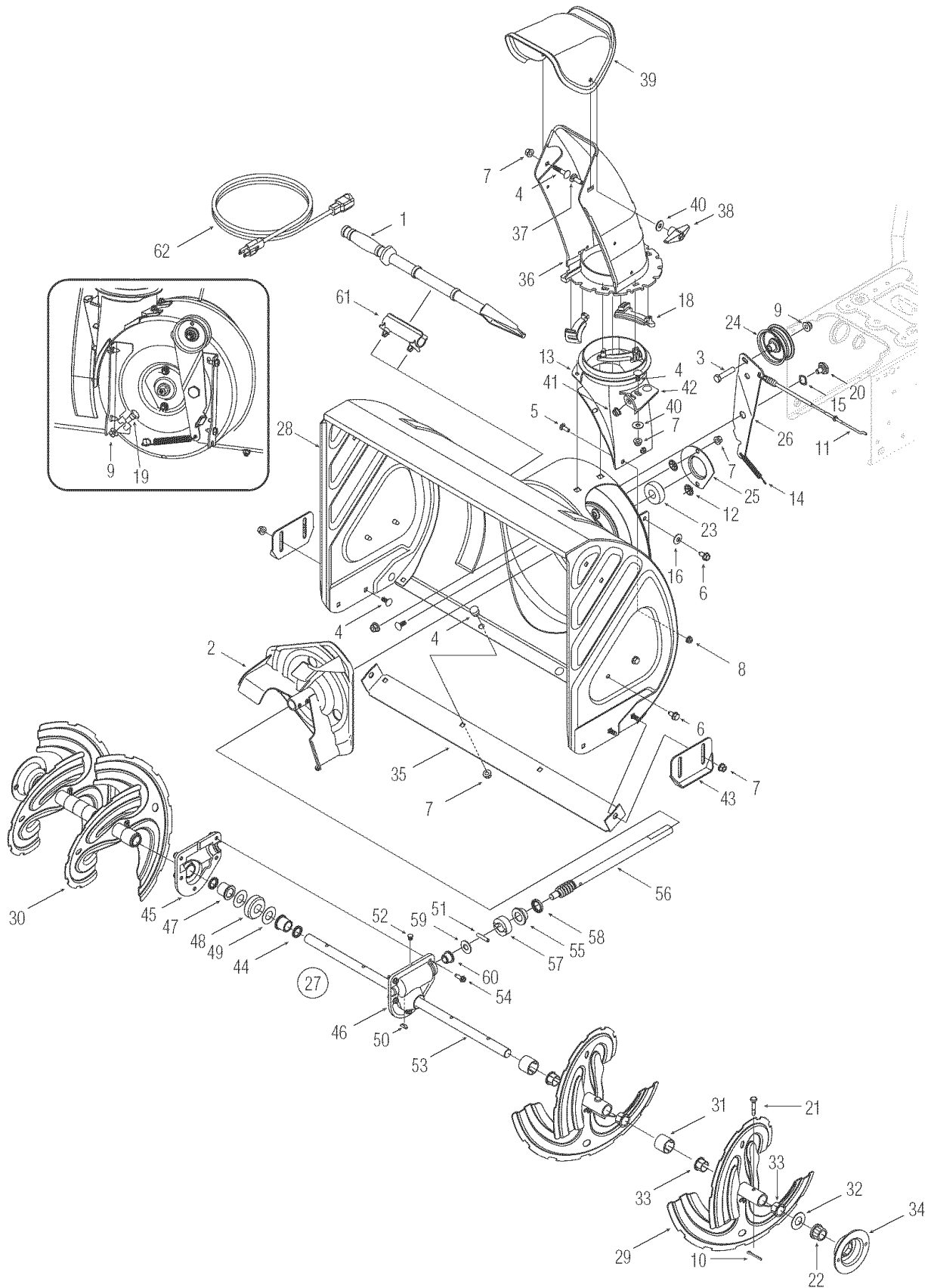

Style N

REF. NO.	PART NO.	DESCRIPTION	REF. NO.	PART NO.	DESCRIPTION
1	731-2643	Removal Tool, Snow	32	736-0188	Washer, Flat, .76 x 1.49 x .06
2	684-04057	Impeller Assembly, 12" Dia	33	741-0493A	Bushing, Flange, .800 ID x .910 OD
3	710-0347	Screw, 3/8-16 x 1.75, Gr5, Std	34	790-00087	Housing, Bearing, 1" Hex
4	710-0451	Bolt, Carriage, 5/16-18 x .750 Gr1	35	790-00120	Plate, Shave, 2.25 x 23.66
5	710-0703	Screw, Carriage, 1/4-20 x .75, Gr5	36	731-04912	Chute, Lower
6	710-0726	Screw, 5/16-12 x 0.750	37	710-04071	Bolt, Carriage, 5/16-18, 1.00
7	712-04063	Nut, Flange Lock, Nylon, 5/16-18, GrF	38	720-0284	Wing Knob, 5/16-18
8	712-04064	Nut, Flange Lock, Nylon, 1/4-20, GrF	39	731-04426A	Chute, Upper
9	712-04065	Nut, Flange Lock, Nylon, 3/8-16, GrF	40	736-0159	Washer, Flat, .349 x .879 x .063
10	714-0507	Pin, Cotter, 3/32 x .750	41	741-0475	Bushing, .380 ID
11	746-0897	Auger Clutch Cable, 44.75"	42	784-5647	Bracket, Chute Crank
12	726-04012	Nut, Push-on, .25 Dia	43	784-5580	Shoe, Slide
13	731-04705	Chute, Adapter 5" Dia	44	721-0179	Seal, Oil, .750 ID
14	732-0611	Spring, Extension, .38 OD x 3.6	45	719-0319	Housing, Auger, RH Reducer
15	736-0174	Washer, Wave, .625 x .885 x .015	46	719-0320	Housing, Auger, LH Reducer
16	736-0242	Washer, Bell, .340 x .872 x .015	47	741-0661A	Bearing, Flange, .75 ID x 1.00 OD x .975
17	736-0463	Washer, Flat, .25 x .630 x .0515	48	717-0528A	Gear, Worm 20T
18	731-04869	Keeper, Flange	49	736-0351	Washer, Flat, .760 ID x 1.5 OD
19	738-0143	Screw, Shoulder, .498 x .340, 3/8-16	50	714-0161	Key, Hi-pro 3/16 x 5/8
20	738-0281	Screw, Shoulder, .625 x .17, 3/8-16	51	715-04021	Pin, Dowel, .25 OD x 1.2
21	738-04124	Pin, Shear, .25 x 1.50, Gr2	52	721-0325	Plug, 1/4 x .437
22	741-0245	Bearing, Hex Flange x .75 ID	53	711-04285	Axle, Auger, 24"
23	741-0309	Bearing, Ball, .75 ID x 1.85 OD	54	710-0642	Screw, Self-tapping, 1/4-20, 0.750
24	756-0981A	Pulley, Idler, Flat 2.75 OD	55	741-0662	Bearing, Flange, .75 ID x 1.00 OD x .59
25	790-00075	Housing, Bearing, 1.85 ID	56	717-04126	Shaft, Worm .75 OD
26	790-00080	Bracket, Auger Idler w/ Brake	57	718-04071	Collar, Thrust
27	618-04171	Gearbox Assembly, Auger, 24"	58	721-0327	Seal, Oil, .75 x 1 x .131
28	684-04077	Housing Assembly, Auger 24"	59	736-3084	Washer, Flat, .51 x 1.12
29	684-04107	Spiral Assembly, LH	60	741-0663	Bearing, Flange, .75 ID x 1.00 OD x .925
30	684-04108	Spiral Assembly, RH	61	731-2635	Mount, Clean Out Tool
31	731-04870	Spacer, 1.25 OD x .75 ID x 1.00	62	629-0071	Extension Cord, 3-Prong



Style N

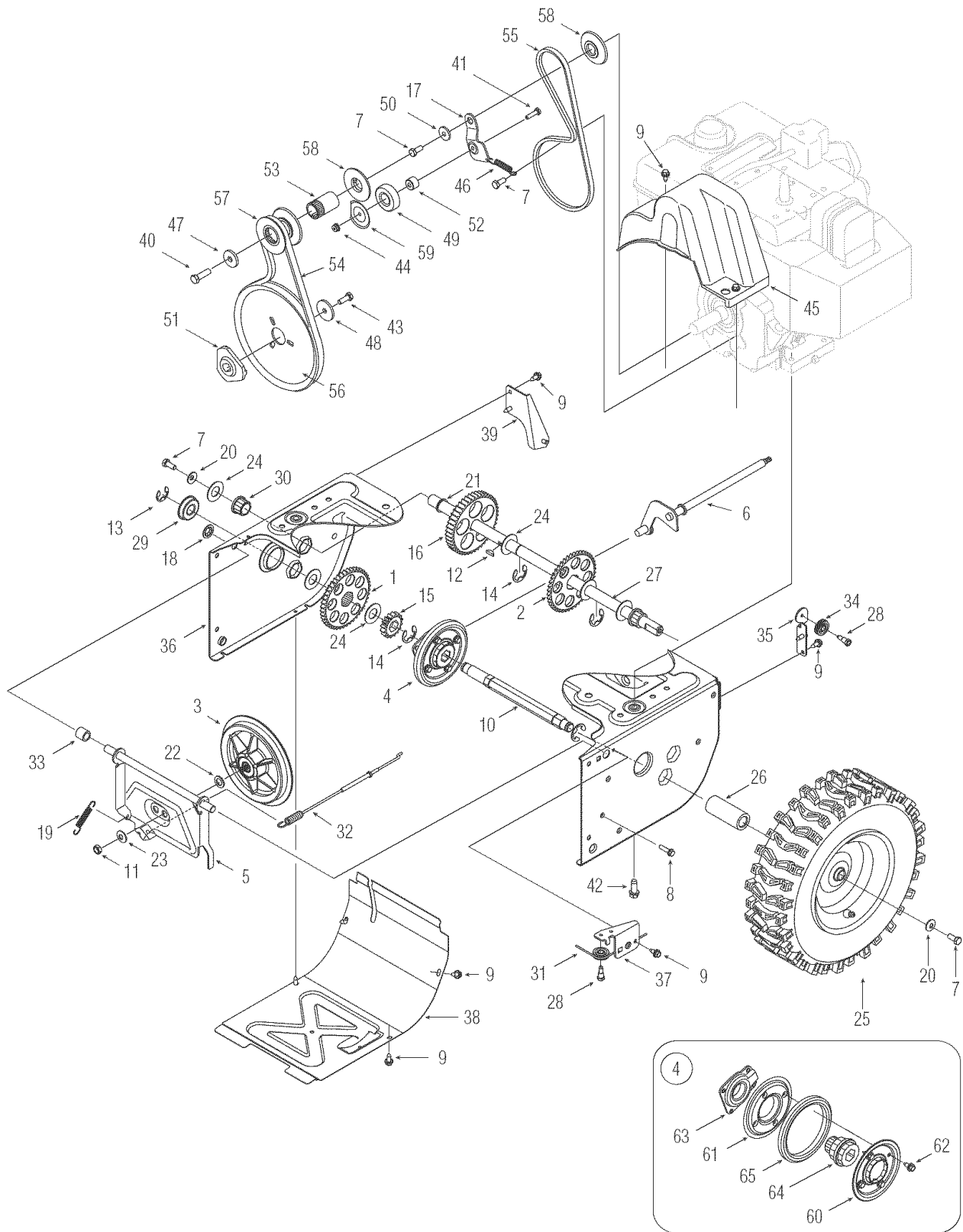

Style N

REF. NO.	PART NO.	DESCRIPTION	REF. NO.	PART NO.	DESCRIPTION
1	617-04026	Gear Assembly, 16/44T	33	748-0190	Spacer, .508 ID x .75 OD x .68
2	617-04025	Gear Assembly, 16/44T	34	756-0625	Roller, Cable
3	656-0012A	Disc Assembly, Friction Wheel, .375	35	784-5687A	Guide Bracket, Auger Cable
4	684-04066	Wheel Assembly, Friction, 4.9 OD	36	790-00072	Frame
5	684-04045	Support Bracket Ass'y, Friction Wheel	37	790-00096	Guide Bracket, Front, Auger Cable
6	684-04139	Shift Assembly, Rod	38	790-00054	Cover, Frame
7	710-0627	Screw, 5/16-24 x .750, Gr5	39	790-00055	Roller Bracket, Drive Cable
8	710-0788	Screw, 1/4-20 x 1.000	40	710-0191	Screw, 3/8-24 x 1.25, Gr8
9	710-1652	Screw, 1/4-20 x .625	41	710-0597	Screw, 1/4-20 x 1.00, Gr5
10	711-04246A	Hex Shaft, Drive, .75	42	710-0654A	Screw, Sems, 3/8-16 x 1.00
11	712-0711	Nut, Jam, 3/8-24, Gr2	43	710-1245B	Screw, 5/16-24 x .875, Gr8
12	714-0161	Key, Hi-pro 3/16 x 5/8	44	712-04064	Nut, Flange Lock, Nylon, 1/4-20, GrF
13	716-0231	Ring, E Type, .750	45	731-04792	Cover, Belt
14	716-0136	Ring, E-Type, .875	46	732-0710	Spring, Extension, .38 OD x 2.68
15	717-04129A	Pinion, 16T	47	736-0247	Washer, Flat, .406 x 1.25 x .157
16	717-04137A	Gear, 44T	48	736-0505	Washer, Flat, .34 x 1.50 x .150
17	790-00082	Idler, Bracket, Drive	49	741-0919	Bearing, Ball, 20 x 47 x 14
18	726-0221	Nut, Speed, .500	50	748-0234	Shoulder Spacer
19	732-0264	Extension Spring	51	748-04053	Pulley, Adapter, .75 Dia.
20	736-0242	Washer, Bell, .340 x .872 x .060	52	750-04230	Spacer, .777 OD x .260 ID x .550
21	736-04161	Washer, Flat, .75 x 1.00 x .060	53	750-04303	Spacer, .875 ID x 1.185 OD
22	736-0300	Washer, Flat, .406 x .875 x .059	54	754-04050	V-Belt, 1/2"
23	736-0105	Washer, Bell, .375 x .870 x .063	55	754-0456	V-Belt, 3/8"
24	736-0287	Washer, Flat, .793 x 1.24 x .060	56	756-04109	Pulley, Auger, 8.1 x .50
25	634-04167	Wheel, Complete, 13 x 4 x 6, LH	57	756-04113	Pulley, Half, 2.600 OD
	634-04168	Wheel, Complete, 13 x 4 x 6, RH	58	756-04114	Pulley, Half, 2.2 OD
26	731-04873	Spacer, 1.25 OD x .75 ID x 3.00	59	790-00062	Washer, Bearing, 2.12 OD x .255 ID
27	738-04095A	Axle, .75 x 22	60	790-00010	Plate, Friction, 12 Pt 4.60 Dia
28	738-0924	Screw, 1/4-28 x .375	61	790-00011	Plate, Friction, Extrs, 12 Pt 4.60 Dia
29	741-0563	Bearing, Ball, 17 x 40 x 12	62	710-0896	Screw, Self-tapping, 1/4-14 x 0.625
30	741-0245	Bearing, Hex Flange x .75 ID	63	618-04169	Bearing Assembly, Friction Wheel
31	746-0897	Cable, Auger, 44.75	64	718-04070	Hub, Friction Wheel
32	746-04086	Cable, Drive, 41.75	65	735-0243B	Friction Wheel Rubber, 4.875 OD

Wheel Assembly Complete	Wheel Size	Rim Only	Tire Only	Air Valve
634-04167	13 x 4 x 6	634-04151	734-04128	734-0255
634-04168	13 x 4 x 6	634-04151	734-04128	734-0255



MANUFACTURER'S LIMITED WARRANTY FOR:



The limited warranty set forth below is given by Troy-Bilt LLC with respect to new merchandise purchased and used in the United States and/or its territories and possessions, and by MTD Products Limited with respect to new merchandise purchased and used in Canada and/or its territories and possessions (either entity respectively, "Troy-Bilt").

"Troy-Bilt" warrants this product (excluding its normal wear parts as described below) against defects in material and workmanship for a period of two (2) years commencing on the date of original purchase and will, at its option, repair or replace, free of charge, any part found to be defective in materials or workmanship. This limited warranty shall only apply if this product has been operated and maintained in accordance with the Operator's Manual furnished with the product, and has not been subject to misuse, abuse, commercial use, neglect, accident, improper maintenance, alteration, vandalism, theft, fire, water, or damage because of other peril or natural disaster. Damage resulting from the installation or use of any part, accessory or attachment not approved by Troy-Bilt for use with the product(s) covered by this manual will void your warranty as to any resulting damage.

Normal wear parts are warranted to be free from defects in material and workmanship for a period of thirty (30) days from the date of purchase. Normal wear parts include, but are not limited to items such as: batteries, belts, blades, blade adapters, grass bags, rider deck wheels, seats, snow thrower skid shoes, friction wheels, shave plates, auger spiral rubber and tires.

HOW TO OBTAIN SERVICE: Warranty service is available, WITH PROOF OF PURCHASE, through your local authorized service dealer. To locate the dealer in your area:

In the U.S.A.

Check your Yellow Pages, or contact Troy-Bilt LLC at P.O. Box 361131, Cleveland, Ohio 44136-0019, or call 1-866-840-6483 or 1-330-558-7220, or log on to our Web site at www.troybilt.com.

In Canada

Contact MTD Products Limited, Kitchener, ON N2G 4J1, or call 1-800-668-1238 or log on to our Web site at www.mtdcanada.com.

This limited warranty does not provide coverage in the following cases:

- a. The engine or component parts thereof. These items may carry a separate manufacturer's warranty. Refer to applicable manufacturer's warranty for terms and conditions.
- b. Log splitter pumps, valves, and cylinders have a separate one- year warranty.
- c. Routine maintenance items such as lubricants, filters, blade sharpening, tune-ups, brake adjustments, clutch adjustments, deck adjustments, and normal

deterioration of the exterior finish due to use or exposure.

- d. Service completed by someone other than an authorized service dealer.
- e. Troy-Bilt does not extend any warranty for products sold or exported outside of the United States and/or Canada, and their respective possessions and territories, except those sold through Troy-Bilt's authorized channels of export distribution.
- f. Replacement parts that are not genuine Troy-Bilt parts.
- g. Transportation charges and service calls.
- h. If Products are used commercially. (*Troy-Bilt may separately offer Limited Commercial Warranties on certain select products. Ask your dealer or retailer for details or contact Troy-Bilt Service for more information.*)

No implied warranty, including any implied warranty of merchantability of fitness for a particular purpose, applies after the applicable period of express written warranty above as to the parts as identified. No other express warranty, whether written or oral, except as mentioned above, given by any person or entity, including a dealer or retailer, with respect to any product, shall bind Troy-Bilt. During the period of the warranty, the exclusive remedy is repair or replacement of the product as set forth above.

The provisions as set forth in this warranty provide the sole and exclusive remedy arising from the sale. Troy-Bilt shall not be liable for incidental or consequential loss or damage including, without limitation, expenses incurred for substitute or replacement lawn care services or for rental expenses to temporarily replace a warranted product.

Some jurisdictions do not allow the exclusion or limitation of incidental or consequential damages, or limitations on how long an implied warranty lasts, so the above exclusions or limitations may not apply to you.

In no event shall recovery of any kind be greater than the amount of the purchase price of the product sold. **Alteration of safety features of the product shall void this warranty.** You assume the risk and liability for loss, damage, or injury to you and your property and/or to others and their property arising out of the misuse or inability to use the product.

This limited warranty shall not extend to anyone other than the original purchaser or to the person for whom it was purchased as a gift.

HOW LOCAL LAWS RELATE TO THIS WARRANTY: This limited warranty gives you specific legal rights, and you may also have other rights that vary in different jurisdictions.

IMPORTANT: Owner must present Original Proof of Purchase to obtain warranty coverage.

Troy-Bilt LLC, P.O. BOX 361131 CLEVELAND, OHIO 44136-0019; Phone: 1-866-840-6483, 1-330-558-7220

MTD Canada Limited - KITCHENER, ON N2G 4J1; Phone 1-800-668-1238