

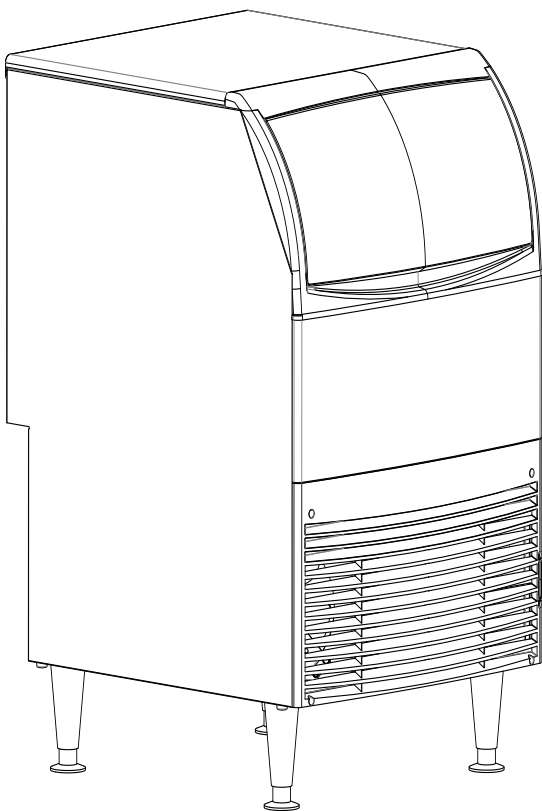

# Installation and User Manual for Model UF424 and UN324



---

To the owner or user: the service manual is intended to provide you and the maintenance or service technician with the information needed to install, startup, clean, maintain and repair this product. Observe any caution or warning notices. They are important and provide notice of potential hazards. Keep this manual for future reference.

If additional technical information is needed, go to Scotsman’s website, [www.scotsman-ice.com](http://www.scotsman-ice.com) to download a service manual.

---

Note: This is a commercial product. If service is needed on a unit in a residence, warranty may be limited. Use a commercial service company. Locate one from the Scotsman website: [www.Scotsman-ice.com](http://www.Scotsman-ice.com)

---

---

## Table of Contents

Specifications .....	3
Cabinet Drawing .....	4
Placement.....	5
Installation: Water and Drain .....	6
Initial Start up.....	7
Maintenance and Cleaning.....	8
Basic Troubleshooting .....	10



## Specifications

This ice maker is designed to be installed indoors, in a controlled environment. Although it can operate in a wide range of air and water temperatures, it will provide the best performance if not subject to extremes.

### Air Temperature Limitations

- Maximum: 100° F or 38° C
- Minimum: 50° F or 10° C

### Water Temperature Limitations

- Maximum: 100° F or 38° C
- Minimum: 40° F or 4.4° C

### Water Pressure, Potable

- Maximum: 80 PSI or 5.5 BAR
- Minimum: 20 PSI or 1.3 BAR

### Water Pressure, Condenser inlet

- Maximum: 145 PSI or 10 BAR
- Minimum: 20 PSI or 1.3 BAR; can be as low as 5 PSI or 0.3 BAR if clean and supplied with 45° F water.

### Condenser GPM

- 70°F or 21°C water: 0.25 GPM or 0.95 LPM
- 50° F or 10°C water: 0.15 GPM or 0.57 LPM

### Voltage

#### 115 volt models

- Maximum 126 VAC
- Minimum 104 VAC

### Water Conductivity:

Minimum: 10 micro Siemens/CM

RO water may be supplied to the potable water system, but if it has less than the above conductivity, the water level sensor will not detect water and the unit will not make ice.

Deionized water is not recommended due to its potential corrosive nature and any damage

caused by DI water will not be covered by warranty.

Operating the machine outside of any of the above limitations is considered abuse and any resulting damage is not covered by warranty and could cause a complete loss of warranty coverage.

### Warranty Information

The warranty statement for this product is provided separately from this manual. Refer to it for applicable coverage. In general warranty covers defects in material or workmanship. It does not cover maintenance, corrections to installations, or situations when the machine is operated in circumstances that exceed the limitations printed above.

### Product Information:

The UF424 produces flaked ice and the UN324 produces nugget ice. The ice is stored in an insulated bin with ice level automatically maintained by the control system.

- A back flow preventer may be required by local plumbing codes.
- Has a 5.5 ft. power cord with NEMA 5-15P plug.
- Air cooled models flows in the right front and out the left front and include a cleanable air filter.
- Legs are provided, thread size is 5/8-11.
- Machine may be installed without legs.
- For available options and kits, see sales literature.

Model	Electrical (Volts/Hz/Phase)	Condenser	Maximum Fuse Size or Breaker (Amps)
UF424A-1A / UN324A-1A	115/60/1	Air	15A
UF424W-1A / UN324W-1A	115/60/1	Water	15A

# Cabinet Drawing

Scotsman Ice Systems are designed and manufactured with the highest regard for safety and performance. They meet or exceed UL563, verified by Intertek, ETL.

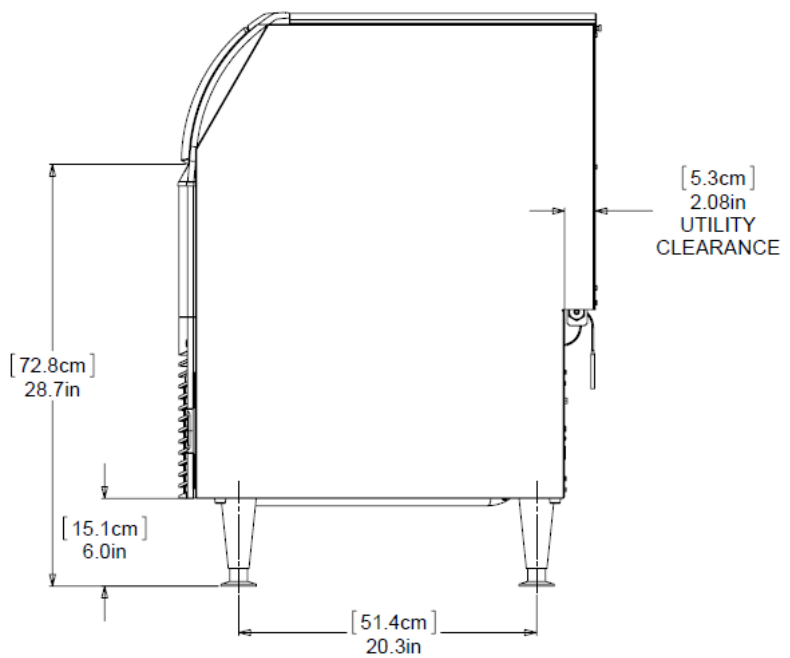
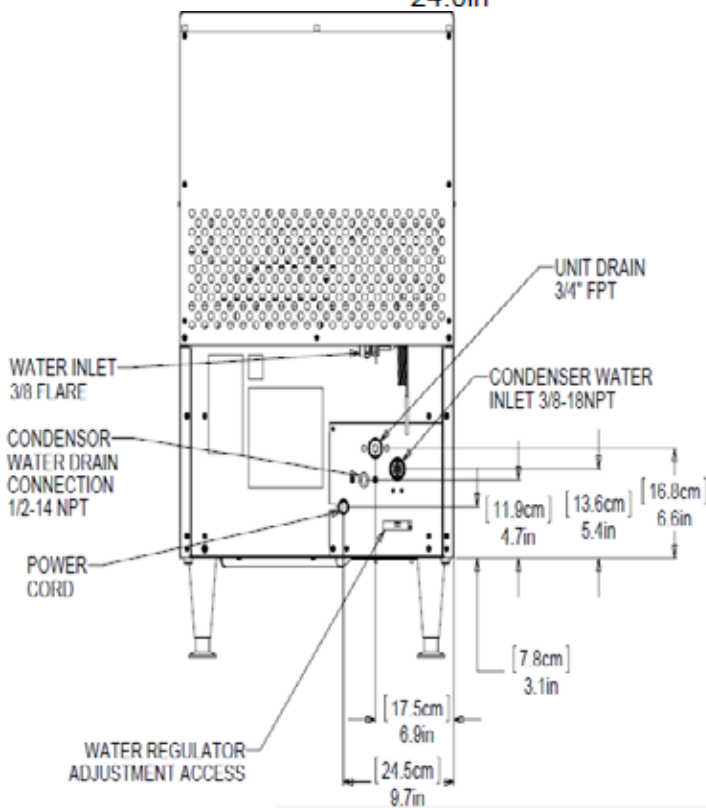
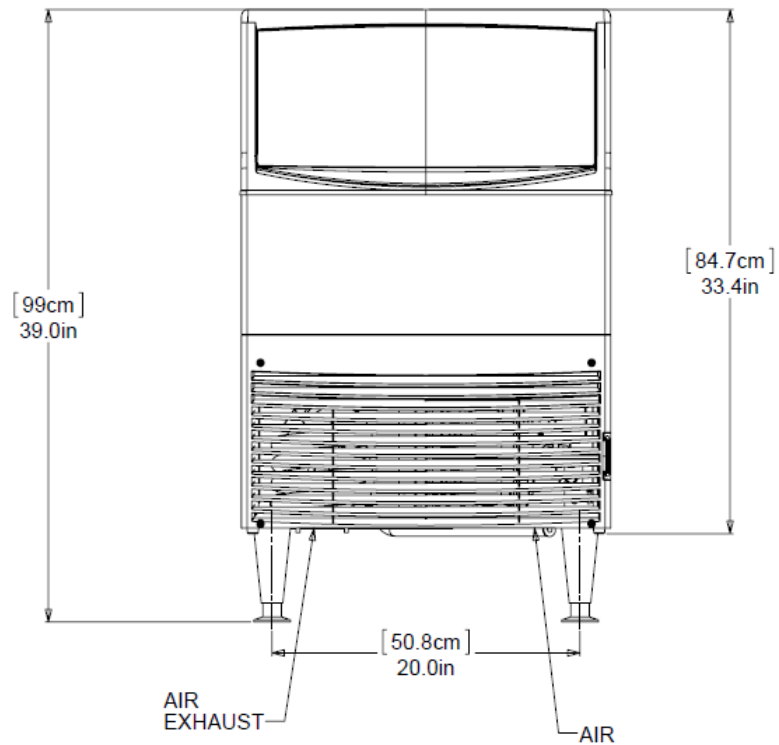
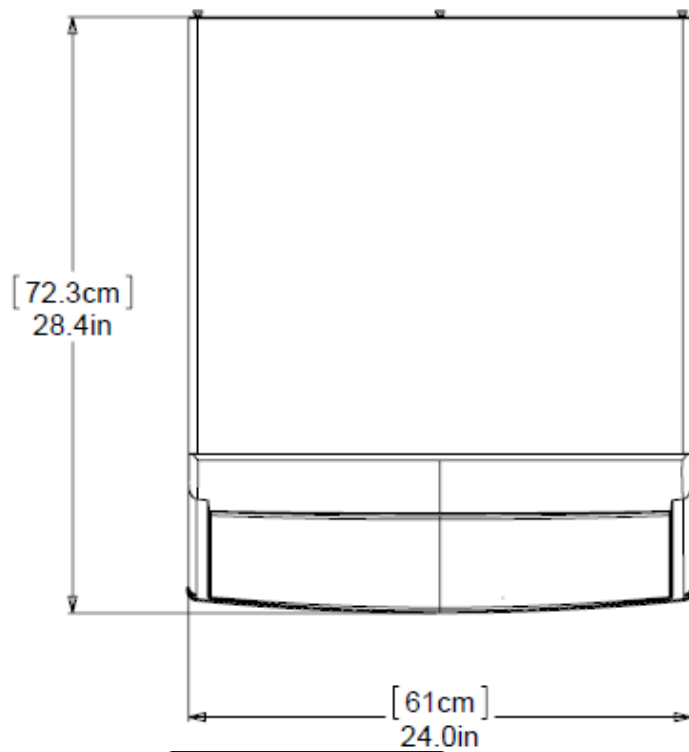

## Placement

---

The location of the equipment should be selected with care. Consideration should be given to allow adequate space for air cooled models to breathe.

The ice machine is not designed for outdoor use. It must be installed indoors, in a controlled environment. The air and water temperatures must not exceed rated limits.

Scotsman assumes no liability or responsibility of any kind from products manufactured by Scotsman that have been altered in any way, including the use of any part and/or other components not specifically approved by Scotsman.

Scotsman reserves the right to make design changes and/or improvements at any time. Specifications and design are subject to change without notice.

### **Airflow on air cooled models:**

Intake from the right grill

Exhaust from the left grill

Do not install where this air flow is blocked.

The power outlet should be located within the length of the supplied power cord. If legs will be used, allow space for the total cabinet height. Air cooled models in a small room will require ventilation to exhaust heat from the condenser. The condenser fan and motor will generate some noise while the machine is running. Noise sensitive areas should consider water cooled equipment or locate the machine where the noise from ice making will not be objectionable.

### **Unpack**

1. Separate the carton from the shipping pallet
2. Inspect for any hidden shipping damage. If any is found, retain carton and notify carrier for potential claim. Shipping damage is not covered by warranty.

---

**Caution:** Tip Over hazard to prevent injury or damage to the machine please use caution when lifting the unit. It will easily tip to the rear.

---

3. Remove bolts holding machine to pallet.
4. Install the legs. The legs are to be screwed into the same holes the shipping bolts were removed.
5. Remove the protective plastic covering the panels. The longer it is left on the panel, the more difficult it will be to remove it.

### **Spacing:**

No additional spacing is required at the top or sides. However, suggested minimum side clearance for the installation is 1/8" or 3.2 mm and suggested minimum top clearance is 1/4" or 6.4 mm.

The machine may be installed with 0 clearance at the back. Do not block louvers at the front of the cabinet.

### **Pre Installation:**

Water supplied to the ice machine should be filtered. Install a filter system that filters out suspended solids. It may be necessary to add a coarse pre-filter ahead of the fine filter.

Inspect the place where the ice machine is to be installed. Check for:

- Space for the cabinet
- Water Supply
- Drain Availability
- Electrical Power Supply

### **DO NOT USE EXTENSION CORDS.**

The building drain inlet must be lower than the drain outlets at the back of the ice machine. The water supply must have a hand shut off valve accessible when the unit is installed.

## Installation: Water and Drain

### For the Plumber

1. Connect cold potable water to the 3/8" male flare behind the lower back panel. A water filter is recommended. Flush the water line prior to connecting to the ice machine.

A loop of copper tubing may be used between the ice machine and the water supply. This will allow the ice machine to be pulled out from its installed location without disconnecting water. No back flow preventer is required in the potable water line. This is provided by the reservoir seat, which is above the reservoir water level and cannot be siphoned

2. Connect a drain tube to the drain fitting. Drain tubes for a water cooled machine should be run separately. The bin drain fitting is 3/4" FPT. And it is plastic. Do not overheat.
  - Drain tube material must be rigid and meet local code.
  - Traps in the bin drain line without vents ahead of them will cause poor draining
  - The bin drain must be vented if there is a long horizontal run 5 feet or more. All drains are gravity and must have a minimum fall of 1/4" per foot of horizontal run.
  - Maintain the air gap required by local code between the end of the drain to, and the building drain receptacle.
  - Drain tubing should be insulated to prevent condensation from forming on the tubing.
3. Water cooled models have a separate 3/8" FPT fitting for condenser water inlet. DO NOT FILTER water to this connection. The condenser drain is 1/2" FPT and does not need a vent.

### For the Electrician

This is a cord-connected unit and must be on a separate single phase power supply. Check the name plate for the correct voltage. The maximum fuse size for this circuit should be 15 A, per the nameplate use fuses or HACR circuit breaker.

**Follow all local codes. This unit must be grounded. Do not use extension cords and do not disable or bypass the ground pin on electrical plug.**

### After utility connections

1. Level the cabinet, use the leg levelers on the end of the legs to adjust to cabinet height. Legs should have been installed when the unit was unpacked.
2. Wash the bin and hood. If desired, the interior of the bin could be sanitized.
3. Locate the scoop, wash it and have it available for use when needed.

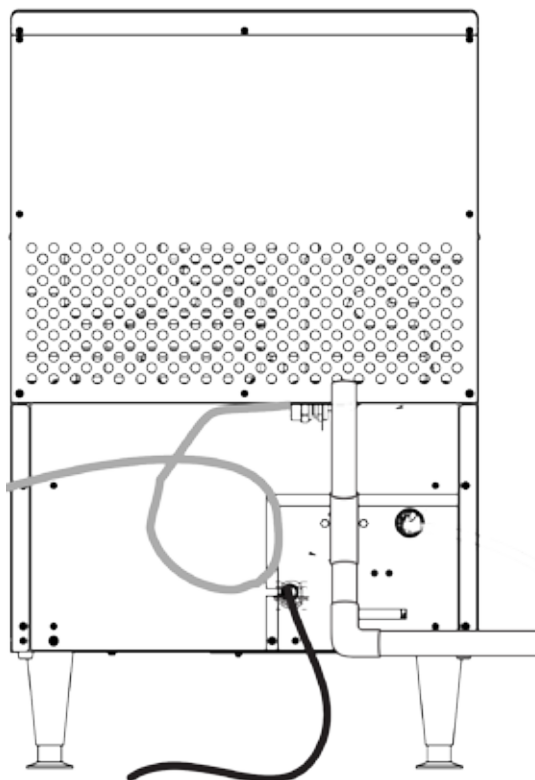

## Initial Start up

### Final check list:

	Ice machine is installed indoors with air and water temperature controlled within the limitations detailed in this manual
	Ice machine is level in its final position
	Electrical disconnect (switch or plug as required) is within sight of the installed machine
	Electrical circuit is dedicated to this ice maker
	Voltage has been confirmed within the specifications in this manual and the name plate on the ice maker
	Plumbing connections are complete and tested for leaks
	Ice maker is installed with proper clearance, allowing for service and utility connections
	Water shut off valve installed near the ice maker

### Start up:

1. Remove louvered front panel.
2. Open bin door and remove the inner panel, held in place by 4 thumb screws.
3. Open the water valve. Observe that water enters the water reservoir, fills and then shuts off. Check for leaks. Repair any leaks before going further.
4. Switch electrical supply on. Lights on controller will flash and then the power light will remain on. The code display will show *D*.
5. Push and release the On/Off button. The machine will start the ice making process. The code display will show *F*. Air cooled models will discharge warm air out the left side of the front panel. Water

cooled models will discharge warm (about 120°F/48°C) water out of the condenser drain. In a few minutes, ice will begin to fall into the bin.

6. Push the on/off button to switch the machine off. Scoop out any ice in the bin.
7. Create a solution of sanitizer. Mix 4oz/118ml of NuCalgon IMS III and 2.5gal/9.5L of (90°F/32°C to 110°F/43°C) potable water to create a 200 ppm solution.
8. Sanitize bin by wiping all surface areas with the sanitizer solution. Allow to air dry.
9. Turn the ice maker on by pressing the on button.
10. Replace inner panel, front cover and louvered panel.
11. Give the owner/user this manual, instruct him/her in the operation and maintenance requirements of the unit. Make sure they know who to call for service.

Fill out the Customer Evaluation and Warranty Registration form, and mail it in to Scotsman or register the unit at Scotsman's website ([www.scotsman-ice.com](http://www.scotsman-ice.com)).

Once started, the ice machine will automatically make ice until the bin level sensors are blocked. This will happen once the ice pile up to the sensors. The typical ice level when the machine is off will be several inches below the door. When ice level drops from use or meltage, the ice machine will resume making ice.

---

Tip: To maximize ice storage scoop the ice to the sides of the bin.

---

### Noise:

This is a commercial ice machine. It contains a powerful compressor, heavy duty gear reducer and, if air cooled, a fan motor. It will produce some noise when it is making ice. Every effort was made during its design to minimize the sound level but some is unavoidable.

## Maintenance and Cleaning

There are 4 areas of maintenance

1. Ice making system
2. Photo eye ice level control system
3. Bin
4. Air cooled condenser and filters

### Ice making System:

#### Remove Scale

1. Remove front panel.
2. Turn the machine off by pressing the on / off button.
3. Empty the ice from the storage bin
4. Remove the inner panel using the 4 thumb screws.
5. Remove the top cover from the reservoir.
6. Shut water supply off at the reservoir by turning the knob counterclockwise.
7. Locate the evaporator drain in the ice machine compartment. Unplug it and drain the evaporator.
8. Replug the drain.
9. Mix a solution of 1.5qt/1.4L of warm water (90°F/32°C to 110°F/43°C) and 4 ounces of Scotsman Clear 1 Ice Machine Scale Remover.
10. Pour the cleaning solution into the reservoir until it is full (a squirt bottle may be necessary to fill reservoir with cleaning solution).
11. Push the clean button. the machine will operate the auger motor for approximately 20 minutes. Then it will start making ice with the cleaning solution.
12. Add remaining cleaning solution to the reservoir as ice is being made for the next 20 minutes. After the full 40 minutes (steps 11 & 12) the unit turn off.
13. Drain the solution from the reservoir by removing the plug. Once drained, replace the plug.
14. Pour clean water into the bin to melt any ice produced during the cleaning cycle.
15. Mix a solution of 4oz/118ml of Scotsman Clear 1 ice machine scale remover and 16oz/473ml of potable water. Use this scale remover solution for the water reservoir cover, ice discharge chutes, the stor-

age bin and the inner front cover.

#### Sanitize Water System

16. Create a solution of sanitizer. Mix 4oz/118ml of NuCalgon IMS III and 2.5gal/9.5L of (90°F/32°C to 110°F/43°C) potable water to create a 200 ppm solution.
17. Pour the sanitizing solution into the reservoir until it is full and wait 2 minutes.
18. Turn on the water supply and press the ON /Off button to turn the ice machine on
19. Operate the machine for at least 15 minutes.
20. Drain the solution from the system by pulling the reservoir plug from the drain hose. Return plug when drained.

#### Photo Eye ice level control

1. Mix solution of 4 ounces of Clear 1 Ice Machine Scale Remover and 1.5qt/1.4L of 90°F/32°C to 110°F/43°C water.
2. Remove sensors from inner cover by removing the white c-clip .
3. Use cotton swab and cleaning solution to thoroughly clean photo sensors.
4. Rinse sensors with clean water.
5. Reinstall sensors in inner panel.



Ice machine cleaner contains acids. Acids can cause burns.

If concentrated cleaner comes in contact with skin, flush with water. If swallowed, do NOT induce vomiting. Give large amounts of water or milk. Call physician immediately. Keep out of the reach of children.

## **Bin**

1. Use the same cleaning mixture to thoroughly clean bin surfaces.
2. Rinse with clean water.
3. Use sanitizer mix on all bin surface areas and areas that may contact the ice.
4. Rinse with clean water.

## **Filters and Air Cooled Condenser**

The air filter located on the lower front grill will capture airborne dust during operation. As the dirt builds up, it begins to restrict air flow and causes the refrigeration system to work less efficiently. Clean the air filter regularly.

1. Remove the filter by sliding it to the right until it is clear of the ice machine.
2. Remove dust and dirt by washing the filter in a utility sink.
3. Reinstall filter in the ice machine.

## **Condenser**

The condenser fins require semi annual cleaning. Use caution to prevent damage to the condenser fins.

1. Lightly brush dust from the condenser.
2. Use a vacuum to thoroughly clean the condenser.

## Basic Troubleshooting

### Troubleshooting

Symptom	Possible Cause	Probable Correction	
No ice in bin	Unit in off mode or off on error code.	Remove front panel and check controller code display. Push ON/OFF button to reset	
	No Power to unit	Check for the power light on the controller. If not illuminated restore power.	
	Auger motor not operating	Open windings. Check motor windings and replace if open.	
		Gear reducer seized, replace gear reducer.	
		Auger bearings seized, replace bearings and seal	
		No power to auger motor, Auger light is ON. Replace controller.	
		Code 2 in controller. Check that sensor rotates with motor and isn't loose. Tighten screw if loose.	
		Code 1 in controller, replace auger motor.	
	Compressor not operating	Contactor coil is open, check and replace if needed.	
		Compressor hot and overheated, check start relay and start capacitor	
		No power to compressor or contactor coil. Compressor light is ON. Replace controller.	
		Compressor at room temperature, will not start. Check windings. If open, replace compressor. If not open, check/replace start relay and start capacitor.	
	Compressor operating, auger turning, no ice is made	Check refrigeration system, TXV may be set to too much superheat or the system is low on refrigerant.	
Excessive noise	Tubing contact	Check for tubes rattling and panels not tight	
	Fan blade out of balance	Replace fan blade	
	Compressor noisy	Replace compressor	
Moaning noise when making ice	Water seal being compressed	Gear reducer bearing failure, replace gear reducer	
Slow or Low production	Condenser is dirty	Check and clean condenser	
	Room and/or Water Temperature too high	Maximum production will be achieved at 70°F / 21°C air and 50° / 10°C water	
	Restricted air flow to unit	Check and remove air flow restrictions	

---

**Controller Diagnostics**

---

<b>Code or Light Action</b>	<b>Probable Cause</b>	<b>Suggested Action</b>
<i>O</i>	Unit manually switched off	If desired, switch unit on.
<i>F</i>	Freeze mode	None, unit is making ice.
<i>b</i>	Bin sensors sense bin full	Check if bin is full.
<i>E</i>	Corrupted memory	Replace controller
<i>C</i>	Clean mode	Continue clean mode
<i>d</i>	Test mode	None, allow unit to finish test mode.
<i>l</i>	Auger motor rotated auger backwards.	Replace auger motor. Check water seal area for leaks, replace seal if leaking.
<i>2</i>	Auger motor stalled or operating slowly	Clean ice making system and retry. If unit shuts off again right after a reset, magnet rotor on motor shaft may be loose.
<i>3</i>	No water in reservoir	Restore water. If there is water, is it too pure? Are sensor wires connected?
<i>4</i>	High pressure cut out open	Check fan motor on air cooled or water supply on water cooled.
Status light is on	Unit is in ice making mode	Normal, may not be making ice if bin is full
Time to Clean light is on	Unit has not been cleaned for at least 6 months	Clean unit
Auger light is on	Auger motor is active	Normal when making ice
Compressor light is on	Compressor is active	Normal when making ice

# **SCOTSMAN ICE SYSTEMS**

101 Corporate Woods Parkway

Vernon Hills, IL 60061

800-726-8762