

EN **Operating and installation instructions X Pure, Pure**

BORA X Pure surface induction cooktop with integrated cooktop extractor – exhaust air/recirculation (PUXA/PUXU)

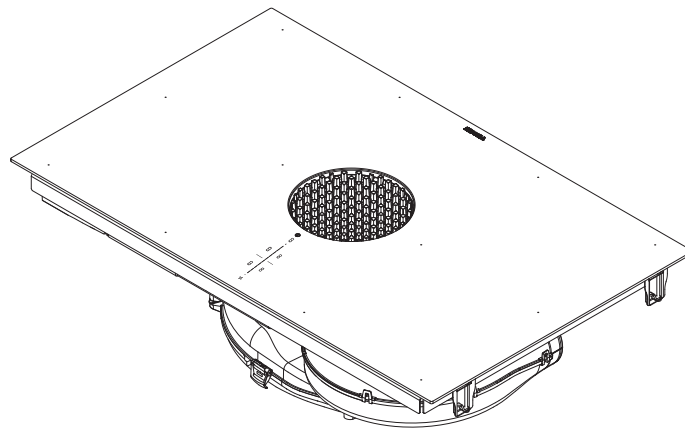

BORA Pure induction cooktop with integrated cooktop extractor – exhaust air/recirculation (PURA/PURU)

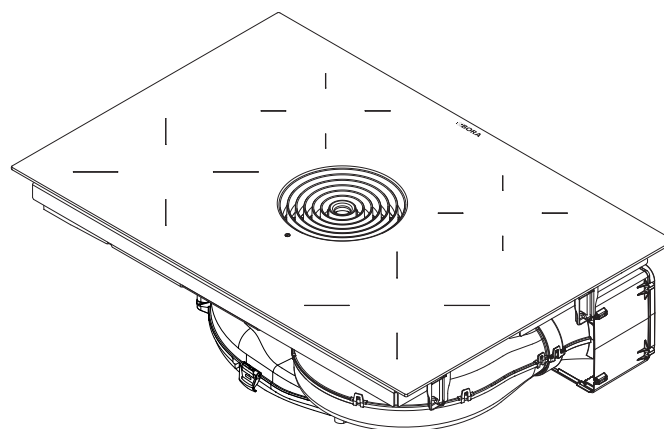

PUREUMEN-101

Table of Contents

1	General information	4		
1.1	Liability.....	4		
1.2	Validity of the operating and installation instructions.....	4		
1.3	Product conformity.....	4		
1.4	Presentation of information.....	4		
2	Safety	5		
2.1	Use as intended.....	5		
2.2	People with limited abilities.....	5		
2.3	General safety instructions.....	5		
2.4	Safety instructions for installation.....	6		
2.5	Safety instructions – operation.....	8		
2.6	Safety instructions – cleaning and maintenance.....	9		
2.7	Safety instructions – repairs, servicing and spare parts.....	10		
2.8	Safety instructions – disassembly and disposal.....	10		
3	Technical data	11		
3.1	X Pure (PUXA, PUXU).....	11		
3.2	Pure (PURA, PURU).....	12		
4	Energy labelling	14		
5	Device description	15		
5.1	Model description.....	15		
5.2	System description.....	15		
5.2.1	Structure.....	15		
5.2.2	Operating panel and operating principle.....	15		
5.2.3	Symbols.....	16		
5.2.4	7-segment display.....	17		
5.2.5	Lighting.....	17		
5.2.6	Sounds.....	17		
5.3	How the cooktop extractor works.....	17		
5.4	How the induction cooktop works.....	17		
	– Power levels.....	18		
	– Suitable cookware.....	18		
	– Noises.....	18		
5.5	Overview of features and functions.....	18		
	– Electronic power adjustment.....	19		
	– Short-time timer (egg timer).....	19		
5.5.1	Cooktop extractor functions.....	19		
	– Automatic extractor control.....	19		
	– Automatic after-run.....	19		
	– Cooktop extractor power setting.....	19		
	– Filter service display.....	19		
5.5.2	Cooktop functions.....	19		
	– Automatic heat up function.....	19		
	– Pan size recognition.....	19		
	– Permanent pan size recognition.....	19		
	– One-level warming function.....	19		
	– Variable warming function (3 levels).....	20		
	– Bridging function.....	20		
	– Automatic bridging function.....	20		
	– Cooking zone timers (automatic cut-off).....	20		
	– Pause function.....	20		
	– Cooktop power setting.....	20		
5.6	Safety devices.....	20		
	– Childproofing feature.....	20		
	– Control lock.....	20		
	– Cleaning lock (wipe function).....	20		
	– Residual heat display.....	20		
5.6.1	Safety shut-down.....	20		
	– Cooktop extractor.....	20		
	– Cooktops.....	20		
5.6.2	Overheating protection.....	21		
6	Installation	22		
6.1	General installation instructions.....	22		
6.1.1	Simultaneous operation of the cooktop extractor in the exhaust air mode and a fireplace dependent upon the air supply in the room.....	22		
6.1.2	Home In module PUHIM (optional).....	23		
6.2	Scope of delivery.....	23		
6.2.1	Checking the scope of delivery.....	23		
6.3	Tool and aids.....	23		
6.4	Assembly instructions.....	23		
6.4.1	Required clearance distances.....	23		
6.4.2	Minimum unit dimensions for X Pure (PUXA, PUXU).....	23		
6.4.3	Minimum unit dimensions for Pure (PURA, PURU).....	24		
6.5	Worktop cut-out.....	24		
6.5.1	X Pure cut-out dimensions (PUXA, PUXU).....	24		
	– X Pure flush installation (PUXA, PUXU).....	24		
	– X Pure surface mounting (PUXA, PUXU).....	24		
6.5.2	Pure cut-out dimensions (PURA, PURU).....	25		
	– Pure flush installation (PURA, PURU).....	25		
	– Pure surface mounting (PURA, PURU).....	25		
6.6	Installing the appliance in exhaust air mode (PUXA, PURA).....	25		
6.6.1	Preparing kitchen units for the exhaust air model.....	25		
	– Installation dimensions.....	26		
	– Adjusting the back wall of the unit.....	26		
6.6.2	Preparing the cooktop.....	26		
	– Attaching the sealing tape.....	26		
	– Fitting the installation clamps.....	26		
6.6.3	Inserting the cooktop.....	27		
	– Height adjustment plates for flush installation(optional).....	27		
6.6.4	Securing the cooktop.....	27		
6.6.5	Connecting the device to the duct system.....	28		
6.7	Installing the recirculation model (PUXU, PURU) of the appliance.....	28		
6.7.1	Recirculation of air from the kitchen unit.....	28		
6.7.2	Installation variants (A and B) for recirculation appliances.....	29		
	– A: floor unit with continuous back wall.....	29		
	– B: floor unit with false floor under the cooktop.....	29		
6.7.3	Preparing kitchen units for installation variant A (floor unit with continuous back wall).....	30		
	– Installation dimensions.....	30		
	– Adjusting the back wall of the unit.....	30		
6.7.4	Preparing kitchen units for installation variant B (floor unit with false floor under the cooktop).....	31		
	– Installation dimensions.....	31		
	– Adjusting the back wall of the unit.....	31		
6.7.5	Preparing the cooktop.....	31		
	– Attaching the sealing tape.....	31		
	– Fitting the installation clamps.....	31		
6.7.6	Extending the telescopic pull-out of the air cleaning box (PULBTA).....	32		
6.7.7	Inserting the cooktop.....	33		
	– Height adjustment plates for flush installation (optional).....	33		

6.7.8	Securing the cooktop.....	33	7.6.5	Menu item 5: Touch zone reaction speed	46
6.7.9	Making a connection with the back wall (only in installation variant A).....	33	7.6.6	Menu item 6: LED test.....	46
6.7.10	Inserting the activated charcoal filter	34	7.6.7	Menu item 7: Permanent pan size recognition	46
6.8	Establishing the power connection.....	35	7.6.8	Menu item 8: Show software/hardware version	47
6.9	Initial operation	36	7.6.9	Menu item 9: Safety shut-down	47
6.9.1	Dealer and service menu	36	7.6.10	Menu item A: Super simple mode	47
	- Dealer and service menu overview	36	7.6.11	Menu item 0: Reset to factory settings	48
	- Calling up the dealer and service menu	36			
	- Menu item B: configuration of the extraction system.....	36			
	- Menu item C: power management.....	37			
	- Menu item D: demo mode.....	37			
	- Closing the dealer and service menu	37			
6.9.2	Function test	37			
6.10	Sealing the device	38			
6.11	Handover to user.....	38			
7	Operation	39	8	Cleaning and Maintenance	49
7.1	General operating instructions.....	39	8.1	Cleaning agents	49
7.2	Touch control.....	39	8.2	Cooktop and extractor care.....	49
7.3	Operating the system.....	39	8.3	Cleaning the cooktop	49
7.3.1	Switching on.....	39	8.4	Cleaning the cooktop extractor.....	50
7.3.2	Switching off	39	8.4.1	Removing the components	50
7.3.3	Control lock	39		- Removing the X Pure air inlet nozzle	50
7.3.4	Childproofing feature	40		- Removing the Pure air inlet nozzle	50
7.3.5	Pause function	40		- Removing the stainless steel grease filter	50
7.3.6	Short-time timer (egg timer)	40	8.4.2	Cleaning the air inlet nozzle and stainless steel grease filter	50
7.3.7	Cleaning lock (wipe function).....	40	8.4.3	Fitting the components.....	50
7.4	Operating the cooktop extractor.....	41		- Inserting the stainless steel grease filter.....	50
7.4.1	Setting the fan power level	41		- Inserting the air inlet nozzle.....	50
7.4.2	Fan power setting.....	41	8.4.4	Removing liquids from the device	51
7.4.3	Automatic extractor control	41	8.5	Cleaning the air guiding housing.....	51
7.4.4	Switching the fan off.....	41		- Opening the air guiding housing.....	51
7.5	Operating the cooktop	41		- Closing the air guiding housing.....	51
7.5.1	Selecting a cooking zone	41	8.6	Replacing the activated charcoal filter.....	52
7.5.2	Setting cooking zone power levels.....	41		- Removing the activated charcoal filter	52
7.5.3	Automatic heat up function.....	42		- Inserting the activated charcoal filter.....	52
7.5.4	Cooktop power setting.....	42			
7.5.5	Setting the warming level.....	42	9	Troubleshooting	54
7.5.6	Setting the variable warming level.....	42	10	Decommissioning, disassembly and disposal	55
7.5.7	Bridging function	42	10.1	Decommissioning	55
7.5.8	Automatic bridging function.....	43	10.2	Disassembly.....	55
7.5.9	Cooking zone timer	43	10.3	Environmentally-friendly disposal	55
7.5.10	Switching off the cooking zone.....	44	11	Warranty, technical service, spare parts, accessories	56
7.6	User menu.....	44	11.1	BORA manufacturer's warranty.....	56
	- Calling up the user menu	44	11.1.1	Warranty extension	56
	- Closing the user menu.....	44	11.2	Service.....	56
	- Navigating the user menu	44	11.3	Spare parts	56
	- User menu overview	44	11.4	Accessories.....	57
7.6.1	Menu item 1: Volume of the acoustic signals	44	12	Notes	58
7.6.2	Menu item 2: Childproofing feature	45			
7.6.3	Menu item 3: Showing and resetting the filter status (only in recirculation mode)	45			
7.6.4	Menu item 4: Duration of the automatic after-run function.....	45			

1 General information

These instructions contain important information to protect you from injury and prevent damage to the appliance. Please read these instructions carefully before installing or using the appliance for the first time.

Other documents apply alongside these instructions. Please by all means adhere to all documents that form part of the scope of delivery.

Assembly and installation may only be carried out by trained specialists and taking into account the applicable laws, regulations and standards. All safety and warning information as well as the handling instructions in the accompanying documents must be observed.

1.1 Liability

BORA Holding GmbH, BORA Vertriebs GmbH & Co KG, BORA APAC Pty Ltd and BORA Lüftungstechnik GmbH – hereinafter referred to as BORA – does not assume any liability for damage arising from disregard for or non-adherence to the documents included in the scope of delivery!

Furthermore, BORA shall not be held liable for damage caused by improper installation or failure to observe the safety and warning instructions!

1.2 Validity of the operating and installation instructions

These instructions apply to several appliance versions. It is therefore possible that some of the features described do not apply to your appliance. The details of the figures contained herein may differ from some appliance versions and are to be understood as schematic diagrams.

1.3 Product conformity

Directives

The appliances meet the following EU/EC directives:

2014/30/EU EMC Directive
2014/35/EU Low Voltage Directive
2009/125/EC Ecodesign Directive
2011/65/EU RoHS Directive

1.4 Presentation of information

We use standard formatting, numbering, symbols, safety instructions, terms and abbreviations so that you can work quickly and safely when using this manual.

The term “appliance” is used to refer to cooktops, cooktop extractors or cooktops with integrated cooktop extractor.

Instructions are indicated with an arrow.

► Always follow all instructions in the prescribed order.

Enumerations are indicated with a bullet point at the start of the line:

- Enumeration 1
- Enumeration 2

i Information notes point to special features that must be taken into account.

Safety and warning instructions



The safety and warning instructions in this manual are emphasised with symbols and signal words.

Safety and warning instructions are structured as follows:

WARNING SYMBOL AND SIGNAL WORD!	
Type and source of danger	Results of non-compliance
► Measures to minimise risk	

Please note:

- warning symbols draw attention to a high risk of injury.
- The signal word indicates the severity of that risk.

Warning symbol	Signal word	Risk
	Danger	Indicates an immediate, hazardous situation which causes death or serious injury if not respected.
	Warning	Indicates a potentially hazardous situation which can cause death or serious injury if not respected.
	Caution	Indicates a potentially hazardous situation which can cause minor injury or damage to property if not respected.

Tab. 1.1 Meaning of the warning symbols and signal words

2 Safety

The appliance complies with the stipulated safety requirements. The user is responsible for the safe use of the appliance, cleaning and maintenance. Improper use can lead to personal injury and damage to property.

2.1 Use as intended

The appliance is solely intended for preparing food in private households.

This appliance is not intended for:

- outdoor use
- heating rooms
- cooling, ventilating or dehumidifying rooms
- use in mobile installation sites such as motor vehicles, ships or aeroplanes
- use with an external timer or a separate remote control system (except for emergency shutdown)
- use at altitudes of over 2,000 m (metres above sea level).

Any other use or any use that goes beyond that which is described here is classed as unintended.

- i** BORA does not assume any liability for damages caused by improper use or incorrect operation.

All misuse is prohibited!

2.2 People with limited abilities

Children

The appliance can be used by children aged 8 and over if they are supervised or have been instructed how to use the appliance safely and understand the resultant risks. Children must not play with the appliance.

- ▶ Use the childproofing feature in order to prevent children from switching on the appliance or changing the settings when they are unattended.
- ▶ Supervise children in the vicinity of the appliance.
- ▶ Do not store any items that could be of interest to children in storage spaces above or behind the appliance. Otherwise, they will be tempted to climb onto the appliance.

- i** Any work involving cleaning and maintenance must not be carried out by children unless they are supervised at all times while doing so.

People with reduced physical, sensory or mental capacities

The appliance can be used by people with reduced physical, sensory or mental capacities or a lack of experience and/or knowledge if they are supervised or have been instructed how to use the appliance safely and understand the resultant risks. Operation can be restricted using the childproofing feature.

⚠ DANGER!

Risk of burns from hot cookware and food

Handles projecting over the edge of the worktop are asking to be grabbed.

- ▶ Keep children away from hot cooking zones or ensure they are supervised at all times.
- ▶ Do not turn pot and pan handles so they stick out beyond the worktop.
- ▶ Make sure that hot pots and pans cannot be pulled down.
- ▶ If necessary, use suitable stove guards or covers.
- ▶ Only use stove guards and covers that are approved by the appliance manufacturer; otherwise, there is a risk of accidents.
- ▶ To choose a suitable stove guard, contact your specialist supplier or the BORA Service Team.

2.3 General safety instructions

⚠ DANGER!

Packaging components are a choking hazard

Packaging components (e.g. film, polystyrene) can be life-threatening for children.

- ▶ Store all packaging components out of reach of children.
- ▶ Dispose of the packaging properly and immediately.

⚠ DANGER!**Risk of electric shock or injury from damaged surfaces**

The underlying electronics can be exposed or damaged due to fissures, fractures or cracks in appliance surfaces (e.g. damaged glass ceramic), particularly in the operating area. This can cause an electric shock. Furthermore, a damaged surface can cause injuries.

- ▶ Do not touch the damaged surface.
- ▶ If there are any cracks, fissures or fractures, switch the appliance off immediately.
- ▶ Safely disconnect the appliance from the mains using the LS switch, fuses, automatic circuit breakers or contactor.
- ▶ Contact BORA Service.

⚠ WARNING!**Risk of injury from damaged components**

Damaged components that cannot be removed without tools can cause injuries.

- ▶ Try not to repair or replace damaged components yourself.
- ▶ Contact BORA Service.

⚠ WARNING!**Risk of injury or damage due to incorrect components or unauthorised modifications**

Incorrect components can lead to personal injury or damage to the appliance. Modifications, additions or alterations to the appliance can lead to safety risks.

- ▶ Only use original components.
- ▶ Do not make any modifications, additions or alterations to the appliance.

CAUTION!**Appliance components can cause injury if dropped**

Appliance components (e.g. pan supports, operating controls, covers, grease filters, etc.) can cause injury if dropped.

- ▶ Place any appliance components that have been removed in a safe place near the appliances.
- ▶ Ensure that no components removed from the appliances can fall on the floor.

CAUTION!**Risk of injury from heavy lifting**

If not handled correctly, carrying and installing appliances can cause injury to the limbs or torso.

- ▶ If necessary, carry and install the appliance with another person.
- ▶ Use appropriate aids to prevent damage or injury.

CAUTION!**Damage from improper use**

The appliance surfaces must not be used as work or storage surfaces. This can damage the appliances (particularly in the case of hard and sharp objects).

- ▶ Never use the appliances as work or storage surfaces.
- ▶ Keep hard or sharp objects away from the appliance surfaces.

Faults and errors

- ▶ In the case of faults and errors, follow the instructions in the “Troubleshooting” chapter.
- ▶ In the event of any faults or errors that are not mentioned, switch the appliance off and contact BORA Service.

Pets

- ▶ Keep pets away from the appliance.

2.4 Safety instructions for installation

- i** The appliance must only be installed and assembled by trained specialists who are familiar with and comply with the standard national regulations and supplementary regulations of the local utility companies.
- i** During installation maintain the minimum clearance stated in the “Installation” (“Safety clearances”) chapter.
- i** Work on electrical components must only be conducted by trained electrical personnel.

The electrical safety of the appliance is only guaranteed if it is connected to a protective conductor system that has been installed in line with regulations. Ensure that this basic safety precaution is met.

The appliance must be suitable for the regional voltage and frequency.

- ▶ Check the information on the identification plate and in the event of deviations, do not connect the appliance.
- ▶ Conduct all work extremely attentively and conscientiously.
- ▶ Do not connect the appliance to the mains until the duct system has been installed or the recirculation filter has been fitted.
- ▶ Only use the connection cables supplied. Where necessary these are included in the scope of delivery.
- ▶ Do not use the appliance until installation is complete. This is the only way to ensure safe operation.

⚠ DANGER!

Risk of electric shock from damaged appliance

A damaged appliance can cause an electric shock.

- ▶ Check the appliance for visible damage prior to installation.
- ▶ Do not install or connect any damaged appliances.
- ▶ Do not operate any damaged appliances.

2.4.1 Safety instructions – cooktop extractor installation

⚠ DANGER!

Risk of electric shock from incorrect stripping of cables

Incorrect stripping of the connection cable to external switching devices results in a risk of electric shock.

- ▶ Ensure that the stated stripping lengths are adhered to.

⚠ WARNING!

Risk of injury due to moving fan wheel

There is a risk of injury while the fan is turning.

- ▶ Only install the device with the power disconnected.
- ▶ Connect both sides of the fan to the duct system before commissioning.

Special safety instructions for the planning of extractor systems

⚠ DANGER!

Risk of smoke inhalation

When the cooktop extractor is used in exhaust air mode, it draws in air from the room it is installed in and from neighbouring rooms. If there is insufficient air supply, low pressure will occur. When used at the same time as a fireplace that is dependent on the air in the room, noxious gases can be sucked into the living areas from the chimney or outlet shaft.

- ▶ Make sure that there is always a sufficient air supply.
- ▶ Only use reliable, tried-and-tested switching devices, (e.g. window contact switch, low pressure warning device) and have them approved by a qualified expert (certified chimney sweep).

Ducting connected to wall sleeves

In the case of straight ducting and a distance < 900 mm between the fan and wall sleeve, a safety guard must be provided for (available as an accessory).

2.4.2 Safety instructions for cooktop installation

⚠ DANGER!

Risk of electric shock from incorrect mains connection

Connecting the appliance to the mains incorrectly poses a risk of electric shock.

- ▶ Make sure that the appliance has a fixed connection to the mains voltage.
- ▶ Make sure that the appliance is connected to a properly installed protective conductor system.
- ▶ Make sure that technical equipment is provided to enable all of the appliance's poles to be disconnected from the mains with a contact opening width of at least 3 mm (LS switch and automatic circuit breakers, fuses, contactor).

⚠ DANGER!**Risk of electric shock from damaged power supply cable**

If the power supply cable is damaged (e.g. during installation or by coming into contact with hot cooking surfaces), this can cause an (lethal) electric shock.

- ▶ Make sure that the power supply cable does not become trapped or damaged.
- ▶ Make sure that the power supply cable does not come into contact with hot cooking surfaces.

2.5 Safety instructions – operation

- ▶ Make sure that the base of the cookware as well as the appliance surfaces are clean and dry.
- ▶ Always lift (do not drag) cookware to prevent scratching and abrasion on the appliance surface.
- ▶ Do not use the appliance as a storage surface.
- ▶ Switch off the appliance after use.

⚠ WARNING!**Risk of burning from hot appliances**

Certain appliances and their exposed parts become hot during use (e.g. cooktops). They should be left to cool down completely after switching off. Touching hot surfaces can cause serious burns.

- ▶ Do not touch hot appliances.
- ▶ Pay attention to the residual heat indicator.

⚠ WARNING!**Risk of burning and fire from hot objects**

The appliance and its exposed parts are hot during operation and the cooling phase. Objects placed on the appliance heat up very quickly and can cause severe burns (this particularly applies to metal objects such as knives, forks, spoons, lids or cooktop extractor covers).

- ▶ Do not place any items on the appliance.
- ▶ Please use suitable accessories (pot holders, oven gloves).

CAUTION!**Damage caused by hot cookware**

Hot cookware can damage certain components in the appliance.

- ▶ Do not put hot cookware down in the area of the operating panel.
- ▶ Keep hot cookware away from the air inlet nozzle.

2.5.1 Safety instructions – cooktop extractor operation**⚠ WARNING!****Fire risk from flambéing**

While the cooktop extractor is working, it sucks up grease from cooking. Flambéing food can cause the grease to catch fire.

- ▶ Clean the cooktop extractor regularly.
- ▶ Never work with a naked flame while the cooktop extractor is running.

CAUTION!**Damage caused by objects or paper suctioned in**

Small and light items, such as cleaning cloths made from material or paper, can be suctioned into the cooktop extractor. This can damage the fan or impair the exhaust performance.

- ▶ Do not store any items or paper on the cooktop extractor.
- ▶ Only operate the integrated cooktop extractor with the grease filter fitted.

CAUTION!**Damage caused by grease and dirt deposits**

Grease and dirt deposits can prevent the cooktop extractor from functioning properly.

- ▶ Never use the cooktop extractor without a correctly fitted stainless steel grease filter.

Special safety instructions for using the exhaust air mode**⚠ DANGER!****Risk of smoke inhalation**

When the cooktop extractor is used in exhaust air mode, it draws in air from the room it is installed in and from neighbouring rooms. If there is insufficient air supply, low pressure will occur. When used at the same time as a fireplace that is dependent on the air in the room, noxious gases can be sucked into the living areas from the chimney or outlet shaft.

- ▶ Make sure that there is always a sufficient air supply.
- ▶ Only use reliable, tried-and-tested switching devices, (e.g. window contact switch, low pressure warning device) and have them approved by a qualified expert (certified chimney sweep).

Special safety instructions for using the recirculation mode

When cooking, additional moisture is released into the ambient air. In recirculation mode, only a slight amount of moisture is removed from the cooking vapour.

- ▶ When using the recirculation mode, ensure a sufficient supply of fresh air, e.g. by opening a window.
- ▶ Ensure a normal and comfortable room climate (humidity of 45–60%), e.g. by opening natural ventilation openings or using domestic ventilation systems.
- ▶ After every use in recirculation mode, switch the cooktop extractor to a low power level for about 20 minutes or activate the automatic after-run function.

2.5.2 Safety instructions – cooktop operation

- ▶ Do not simply rely on the pan size recognition function on induction cooktops; always switch the appliance off after use.

DANGER!

Danger of fire caused by leaving the cooktop unattended

Oil or fat in the pot can quickly heat up and ignite.

- ▶ Never leave oil or fat to heat up unattended.
- ▶ Never extinguish oil and fat fires with water.
- ▶ Switch off the cooktop.
- ▶ Extinguish the fire using a pan lid or a fire blanket, for example.

DANGER!

Danger of explosion caused by flammable liquids

Flammable liquids in the vicinity of a cooktop can explode and cause serious injury.

- ▶ Do not spray aerosols near the appliance when it is in use.
- ▶ Do not place any flammable liquids in the vicinity of a cooktop.

WARNING!

Risk of burns from hot liquids boiling over

Unattended pans can boil over allowing hot liquids to escape.

- ▶ Keep an eye on pans when cooking.
- ▶ Try not to let them boil over.

WARNING!

Risk of burns from hot steam

Liquid between the cooking zone and the pan base can evaporate and cause burns.

- ▶ Make sure that the cooking zone and the pan base are always dry.

WARNING!

Risk of burns due to power cut

During or after a power cut, a cooktop that was previously in operation may still be hot even though there is no indication of residual heat.

- ▶ Do not touch the cooktop while it is still hot.
- ▶ Keep children away from the hot cooktop.

CAUTION!

Damage caused by sugary and salty foods

Sugary and salty foods and juices can damage the hot cooking zone.

- ▶ Make sure sugary and salty foods or juices do not get onto the cooking zone while it is hot.
- ▶ Remove sugary and salty foods and juices from the hot cooking zone immediately.

Special safety instructions for the operation of induction cooktops

Effect on pace makers, hearing aids and metal implants:

induction cooktops generate a high-frequency electromagnetic field in the area of the cooking zones. The cooking zones may affect pacemakers, hearing aids or metal implants negatively or disturb their function when in close proximity. A reduced function of the pacemaker is unlikely.

- ▶ If in doubt, contact the manufacturer of your medical device, or your doctor.

2.6 Safety instructions – cleaning and maintenance

The appliance must be cleaned at regular intervals. Dirt can lead to damage, restriction of functions, or bothersome odours. In the worst case scenario, this can become a hazard.

- ▶ Remove dirt immediately.
- ▶ When cleaning, only use non-abrasive detergents to prevent scratching and abrasion on the surface.
- ▶ When cleaning, ensure that no water penetrates the appliance. Use only a slightly damp cloth. Never spray the device with water. Water penetration can cause damage!

- ▶ Do not use a steam cleaner for cleaning. Steam can cause a short circuit on live parts and thus lead to property damage.
- ▶ Please follow all instructions in the “Cleaning and Maintenance” chapter.

Special safety instructions for cooktop extractor cleaning and maintenance

- ▶ Keep the ventilation openings in the unit below open and clean.

WARNING!

Risk of fire from fat deposits

The risk of fire can be increased by failure to clean the grease filter properly and on a regular basis, or if the filter change is overdue.

- ▶ Clean and replace the filter at regular intervals.

WARNING!

Risk of injury when opening the bottom housing cover



There is a risk of injury while the fan is turning.

- ▶ Switch off the appliance and disconnect it from the mains before removing covers in the vicinity of the fan.

Special safety instructions for cooktop cleaning and maintenance

- ▶ Whenever possible, clean the cooktops after every use.
- ▶ Only clean the cooktops when they have cooled down.

2.7 Safety instructions – repairs, servicing and spare parts

-  The appliance must only be repaired and serviced by trained specialists who are familiar with and comply with the standard national regulations and supplementary regulations of the local utility companies.
-  Work on electrical components must only be conducted by trained electrical personnel.
- ▶ Before any repair work, safely disconnect the appliance from the mains supply.

WARNING!



Risk of injury or damage from improper repairs

Incorrect components can lead to personal injury or damage to the appliance. Modifications, additions or alterations to the appliance can lead to safety risks.

- ▶ Only use original spare parts for repairs.
- ▶ Do not make any modifications, additions or alterations to the appliance.

-  A damaged power supply cable must be replaced by a suitable power supply cable. This may only be done by an authorised member of the After Sales Service team.

2.8 Safety instructions – disassembly and disposal

-  The appliance must only be disassembled by trained specialists who are familiar with and comply with the standard national regulations and supplementary regulations of the local utility companies.
-  Work on electrical components must only be conducted by trained electrical personnel.
- ▶ Before disassembly, safely disconnect the appliance from the mains supply.

DANGER!

Risk of electric shock from incorrect disconnection

Incorrectly disconnecting the appliance from the mains results in a risk of electric shock.

- ▶ Securely disconnect the appliance from the mains using LS switches, fuses, automatic circuit breakers or contactors.
- ▶ Use an authorised measuring device to ensure that there is no power to the appliance.
- ▶ Do not touch exposed contacts on the electronic unit as they may contain residual charge.

3 Technical data

3.1 X Pure (PUXA, PUXU)

Parameter	Value
Multiphase supply voltage	380-415 V 2N/3N
Single-phase supply voltage	220-240 V
Frequency	50 Hz/60 Hz
Maximum power consumption	7,6 kW (4,4 kW / 3,6 kW)
Fuse protection/Three-phase power supply	3 x 16 A
Fuse protection/Two-phase power supply	2 x 16 A
Fuse protection/Single-phase power supply	1 x 32 A (1 x 20 A / 1 x 16 A)
Dimensions (width x depth x height)	830 x 515 x 199 mm
Weight (incl. accessories/packaging)	23 kg (PUXA) 24,5 kg (PUXU)
Cooktop	
Material surface	glass ceramic
Power levels	1 - 9, P
Front cooking zone size	230 x 230 mm
Front cooking zone power setting output	2100 W 3000 W
Rear cooking zone size	230 x 230 mm
Rear cooking zone power setting output	2100 W 3000 W
Cooktop energy consumption (pan size)	
Cooking zone 1 front left (150 mm)	179,4 Wh/kg
Cooking zone 2 back left (180 mm)	176,2 Wh/kg
Cooking zone 1 and 2 bridget (240 mm)	191,5 Wh/kg
Cooking zone 3 front right (150 mm)	174,7 Wh/kg
Cooking zone 4 back right (180 mm)	177,5 Wh/kg
Cooking zones 3 and 4 bridget (240 mm)	197,1 Wh/kg
Total (average)	182,7 Wh/kg
Extraction system (PUXA)	
Power levels	1 - 9, P
Exhaust air connection	BORA Ecotube
Recirculation system (PUXU)	
Power levels	1-9, P
Recirculation connection (WxH)	445 x 137 mm
Recirculation filter (PUXU)	
Maximum filter capacity	150 (1 year)

Tab. 3.1 Technical data X Pure (PUXA, PUXU)

Device dimensions PUXA

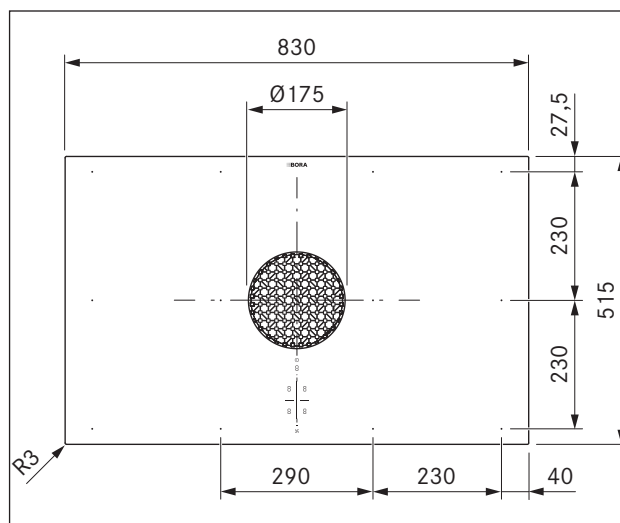

Fig. 3.1 PUXA device dimensions top view

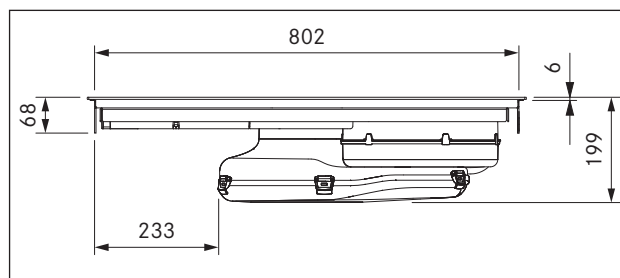

Fig. 3.2 PUXA device dimensions front view

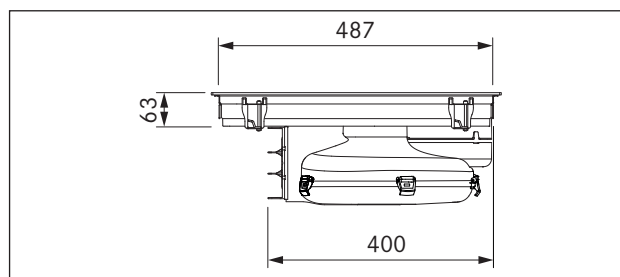

Fig. 3.3 PUXA device dimensions side view



Device dimensions PUXU

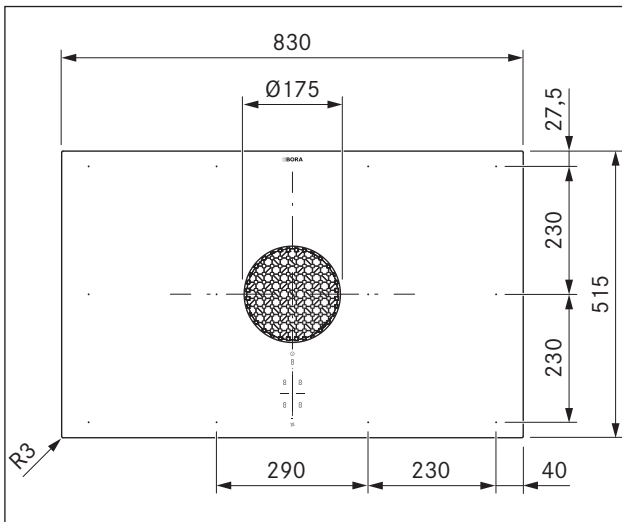

Fig. 3.4 PUXU device dimensions top view

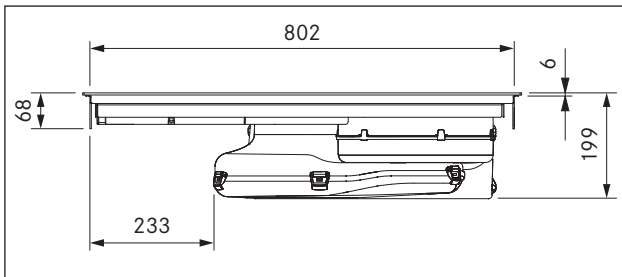

Fig. 3.5 PUXU device dimensions front view

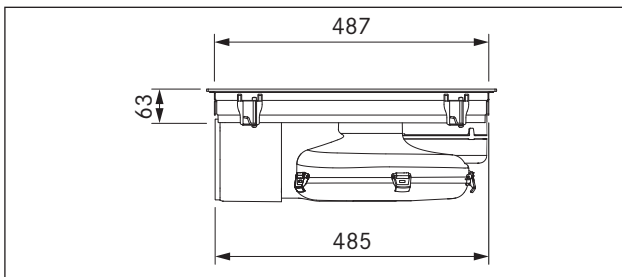

Fig. 3.6 PUXU device dimensions side view

3.2 Pure (PURA, PURU)

Parameter	Value
Multiphase supply voltage	380-415 V 2N/3N
Single-phase supply voltage	220-240 V
Frequency	50 Hz/60 Hz
Maximum power consumption	7,6 kW (4,4 kW / 3,6 kW)
Fuse protection/Three-phase power supply	3 x 16 A
Fuse protection/Two-phase power supply	2 x 16 A
Fuse protection/Single-phase power supply	1 x 32 A (1 x 20 A / 1 x 16 A)
Dimensions (width x depth x height)	760 x 515 x 199 mm
Weight (incl. accessories/packaging)	22,5 kg (PURA) 24,4 kg (PURU)
Cooktop	
Material surface	glass ceramic
Power levels	1 – 9, P
Front cooking zone size	Ø 210 mm
Front cooking zone power setting output	2300 W 3000 W
Rear cooking zone size	Ø 175 mm
Rear cooking zone power setting output	1400 W 2100 W
Cooktop energy consumption (pan size)	
Cooking zone 1 front left (210 mm)	186.3 Wh/kg
Cooking zone 2 back left (180 mm)	177.2 Wh/kg
Cooking zone 3 front right (210 mm)	191.5 Wh/kg
Cooking zone 4 back right (150 mm)	177.2 Wh/kg
Total (average)	183.1 Wh/kg
Extraction system (PURA)	
Power levels	1 – 9, P
Exhaust air connection	BORA Ecotube
Recirculation system (PURU)	
Power levels	1-9, P
Recirculation connection (WxH)	445 x 137 mm
Recirculation filter (PURU)	
Maximum filter capacity	150 (1 year)

Tab. 3.2 Technical data Pure (PURA, PURU)

Device dimensions PURA

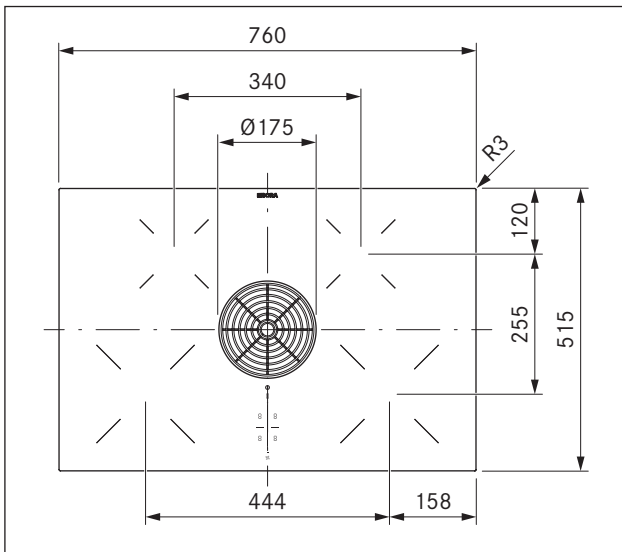

Fig. 3.7 PURA device dimensions top view

Device dimensions PURU

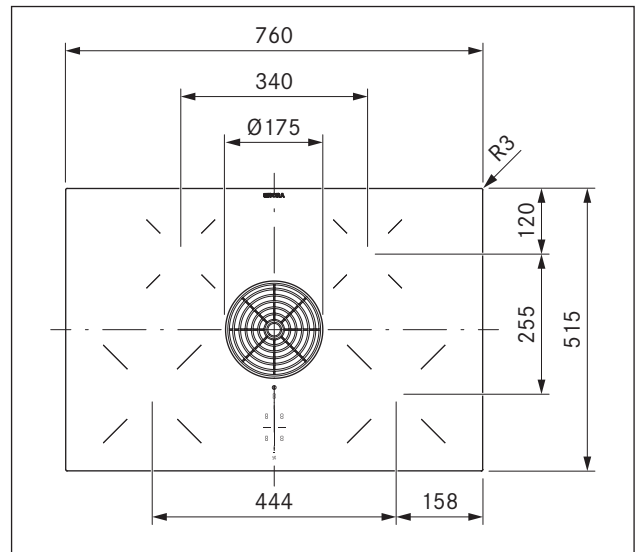

Fig. 3.10 PURU device dimensions top view

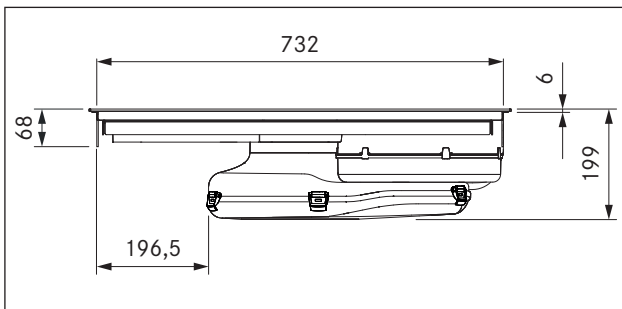

Fig. 3.8 PURA device dimensions front view

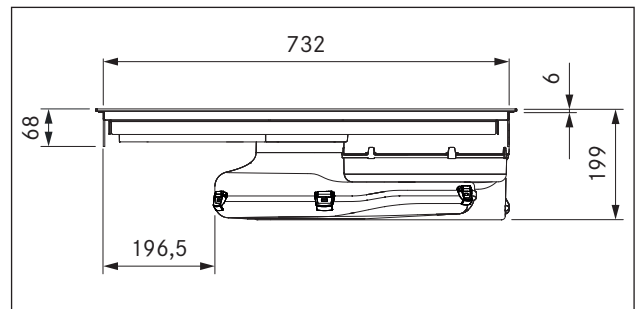

Fig. 3.11 PURU device dimensions front view

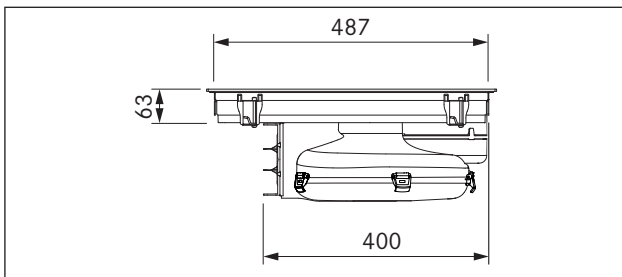

Fig. 3.9 PURA device dimensions side view

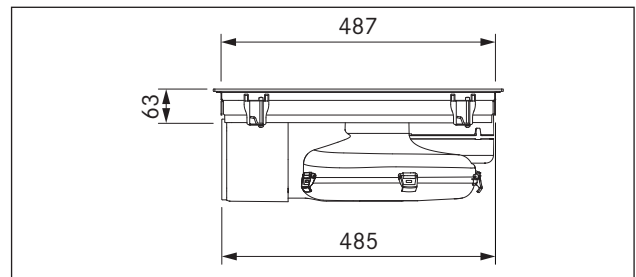

Fig. 3.12 PURU device dimensions side view

4 Energy labelling

Product description	BORA X Pure surface induction cooktop with integrated cooktop extractor PUXA	BORA Pure induction cooktop with integrated cooktop extractor PURA	
Operating mode	Exhaust air	Exhaust air	
Energy consumption	Value	Value	EN standard
Annual energy consumption (AEC_{hood})	35,6 kWh/a	33.7 kWh/a	61591
Energy efficiency class	A+	A+	61591
Flow volume			
Fluid dynamic efficiency (FDE_{hood})	32,9 %	32.6 %	61591
Fluid dynamic efficiency class	A	A	61591
Air flow level 1 minimum	187,3 m ³ /h	179.1 m ³ /h	61591
Air flow level 9 maximum	563,3 m ³ /h	548.3 m ³ /h	61591
Air flow power level (Q_{Max})	626,1 m ³ /h	622 m ³ /h	61591
Lighting			
Lighting efficiency (LE_{hood})	* lx/Watt	* lx/Watt	*
Lighting efficiency class	*	*	*
Grease filtering			
Level 9 maximum (GFE_{hood})	96,4 %	97.8 %	61591
Class at maximum level	A	A	61591
Sound power level			
Level 1 minimum	41,2 dB(A)	40.1 dB(A)	60704-2-13
Level 9 maximum	66,4 dB(A)	65.8 dB(A)	60704-2-13
Power setting	68,6 dB(A)	67.7 dB(A)	60704-2-13
Sound pressure level (additional details)			
Level 1 minimum	28,6 dB(A)	27.5 dB(A)	**
Level 9 maximum	53,8 dB(A)	53.2 dB(A)	**
Power setting	56,0 dB(A)	55.1 dB(A)	**
Details according to 66/2014			
Power consumption in off mode (P_o)	0,18 W	0.12 W	61591
Time increase factor	0,8	0.8	61591
Energy efficiency index (EEI_{hood})	43,3	42.8	61591
Air flow rate at the best efficiency point (Q_{BEP})	313,4 m ³ /h	304.3 m ³ /h	61591
Pressure at the best efficiency point (P_{BEP})	460,7 Pa	446 Pa	61591
Electric power input at the best efficiency point (W_{BEP})	122,0 W	115.5 W	61591

Tab. 4.1 Energy labelling instructions according to directive (EU) 65/2015 and 66/2014 respectively

* This specification is not applicable for this product.

** The sound pressure level has been determined from a distance of 1 m (distance-dependent level recording) on the basis of the sound power level established in EN 60704-2-13.

5 Device description

Observe all safety and warning information during operation (see Safety chapter).

5.1 Model description

Model	Long description
PUXA	BORA X Pure surface induction cooktop with integrated cooktop extractor – exhaust air
PUXU	BORA X Pure surface induction cooktop with integrated cooktop extractor – recirculation
PURA	BORA Pure induction cooktop with integrated cooktop extractor – exhaust air
PURU	BORA Pure induction cooktop with integrated cooktop extractor – recirculation

Tab. 5.1 Model description

5.2 System description

5.2.1 Structure

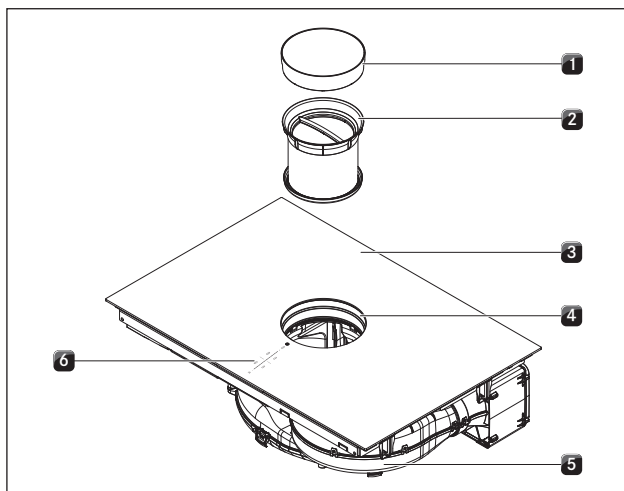

Fig. 5.1 Cooktop

- [1] Air inlet nozzle
- [2] Stainless steel grease filter
- [3] Cooktop
- [4] Inlet opening
- [5] Fan
- [6] Operating panel

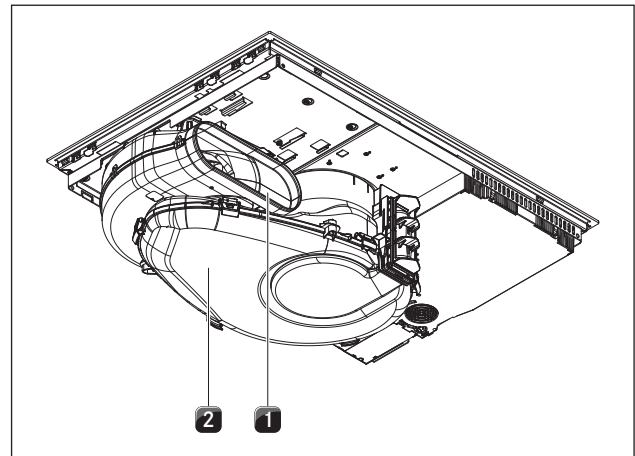

Fig. 5.2 Back view of PUXA, PURA

- [1] Exhaust opening
- [2] Air guiding housing with housing base

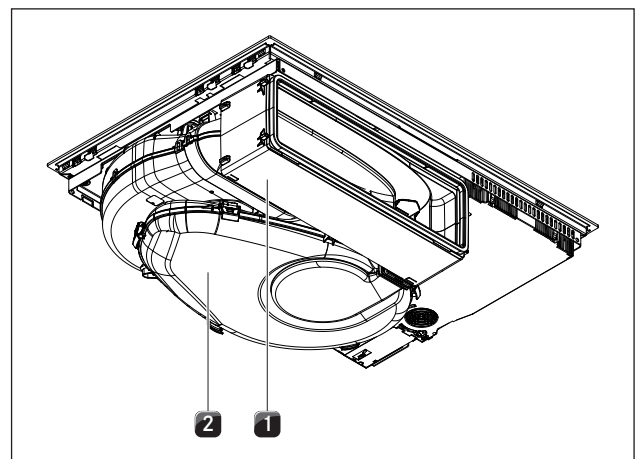

Fig. 5.3 Back view of PUXU, PURU

- [1] Air cleaning box with telescopic pull-out
- [2] Air guiding housing with housing base

5.2.2 Operating panel and operating principle

- i** The operating principle and functions are described in more detail in the Operation chapter.

The cooktop extractor and cooktops are operated via a central operating panel. The operating panel is fitted with electronic sensor buttons and display panels. The sensor buttons respond to finger contact (touch zones).

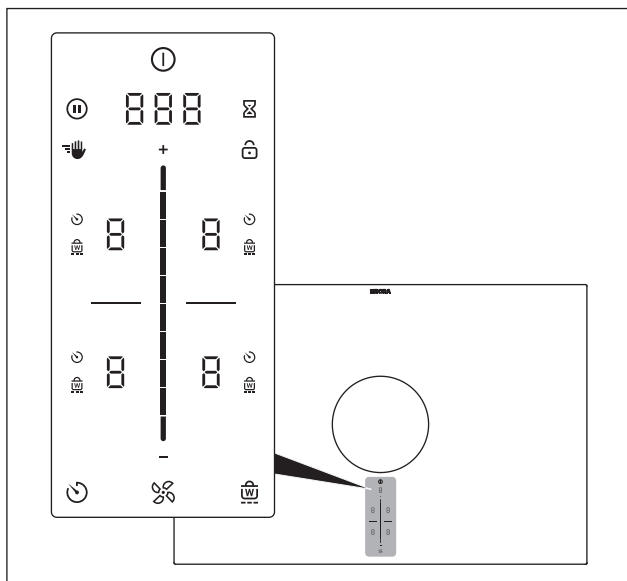

Fig. 5.4 Central touch/slider operating panel

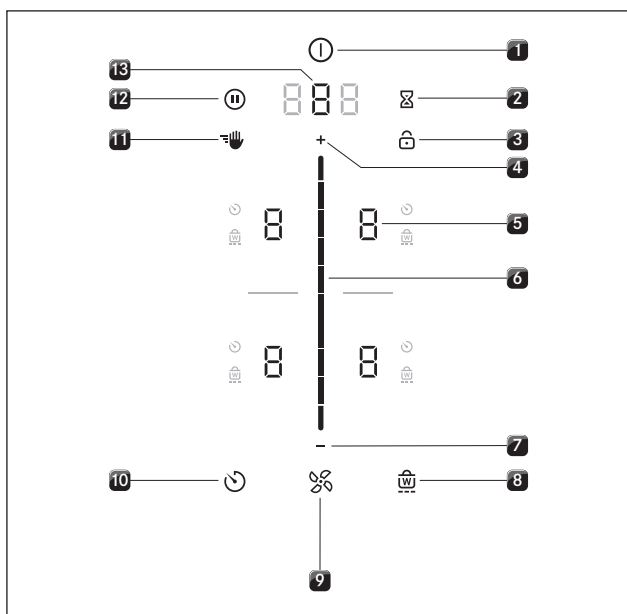

Fig. 5.5 Touch zones/buttons

- [1] Switching on/off
- [2] Short-time timer (egg timer)
- [3] Display lock
- [4] Power level setting zone plus
- [5] Cooking zone selection (4x)
- [6] Touch slider (power level setting zone)
- [7] Power level setting zone minus
- [8] Warming function
- [9] Fan functions
- [10] Cooking zone timer
- [11] Cleaning lock
- [12] Pause function
- [13] Select fan/Call up menu

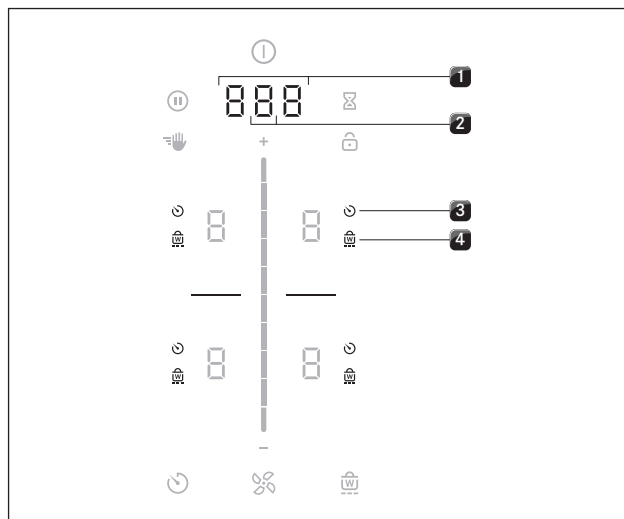

Fig. 5.6 Indicator zones

- [1] Multi-function display
- [2] Fan display
- [3] Cooking zone timer indicator (4x)
- [4] Warming indicator (4x)

5.2.3 Symbols

Symbols	Description	Function/meaning
	Power button	Switching on/off
	Pause button	Activating/deactivating the pause function
	Cleaning button	Activating/deactivating the cleaning lock
	Egg timer button	Setting the short-time timer (egg timer)
	Lock button	Display lock
	Slider	Setting values
	Plus button	Increasing values
	Minus button	Decreasing values
	Fan button	Activating/deactivating the automatic extractor function, cancelling the after-run function
	Timer button	Setting the cooking zone timer
	Warming button	Activating/deactivating the warming function

Tab. 5.2 Meaning of the symbols displayed (icons)

5.2.4 7-segment display

Multi-function display		Meaning
Fan display	- 9	Power levels
	P	Power setting
	□	Inactive
	A	Automatic extractor function
	⌂	Automatic after-run
	F	Filter service
Multi-function display	□□□□	Time indication
	e.g. E	Error code
Cooking zone indicator		Meaning
Cooking zone indicator	- 9	Power level
	P	Power setting
	⌂	Warming level (Pure)
	—	Warming level 1 (X Pure)
	≡	Warming level 2 (X Pure)
	≡≡	Warming level 3 (X Pure)
	⌂	Pan size recognition
	□	Inactive
	H	Residual heat indicator (cooking zone is switched off but still hot)
	—	
	E	Error

Tab. 5.3 Meaning of the 7-segment displays

5.2.5 Lighting

- i** The operating panel has 2 different levels of lighting (100% and 50%).
- i** On principle the system adapts the lighting to the current operating scenario. Relevant display elements are more brightly lit and irrelevant ones are dimmed. Unavailable functions are faded out.

Lighting	Use
100%	Function is active and selected
50%	Function is inactive but can be selected
0% (no indicator)	Function is unavailable

Tab. 5.4 Lighting

5.2.6 Sounds

- i** The volume of the acoustic signals can be set in the menu (0% to 100%).
- i** The acoustic signal for the power button cannot be set to 0.
- i** Safety-relevant acoustic signals are always emitted with the volume at 100%.

The system basically differentiates between two different types of acoustic signals:

Acoustic signal	Purpose
Short individual beep (0.1 s)	Confirmation of a selection
Sequence of beeps	Interaction required

Tab. 5.5 Sounds

5.3 How the cooktop extractor works

Depending on the model you purchased, the cooktop extractor can be operated as an exhaust air or a recirculating air version.

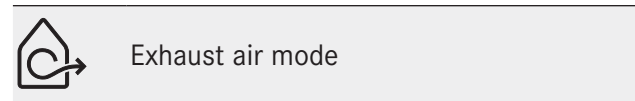

The air suctioned away is purified by the grease filter and expelled into the open air via a duct system.

The exhaust air must not be expelled into:

- a smoke or exhaust gas flue that is in operation
- a shaft used for the aeration of rooms where fireplaces are installed.

If the exhaust air is to be directed into a smoke or exhaust gas flue that is not in use, the installation must be checked and approved by the responsible heating engineer.

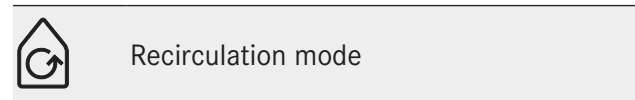

The air suctioned away is purified by the grease filter and an activated charcoal filter and fed back into the room in which the appliance is installed.

To prevent odours in recirculation mode, an odour filter must be used. For hygiene and health reasons, the activated charcoal filter must be replaced at the recommended intervals (see the Cleaning and maintenance chapter).

- i** In recirculation mode, ensure sufficient ventilation and aeration to expel humidity.

5.4 How the induction cooktop works

An induction coil is located underneath an induction cooking zone. If the cooking zone is switched on, this coil creates a magnetic field that acts directly on the base of the pot thus heating it up. The cooking zone is only indirectly heated up by the heat emitted by the pot. Cooking zones with induction only work if the cookware has a magnetisable base.

The induction automatically takes into account the size of the used cookware which means that only the area in the cooking zone covered by the base of the pot is heated up.

- ▶ Observe the minimum pot base diameter.

Power levels

The high power output of induction cooktops results in the very quick heating up of cookware. In order to avoid burning food, slight adjustment is needed in comparison to conventional cooking systems when selecting the power level.

Activity	Power level
Melting of butter and chocolate, breaking up gelatine	1
Keeping sauces and soups warm, soaking rice	1 - 3
Cooking potatoes, pasta, soups, ragouts, steaming fruit, vegetables and fish, defrosting food	2 - 6
Frying in coated pans, moderate frying (without overheating the fat) of pork cutlets, fish	6 - 7
Heating up fat, browning fish, cooking thickened sources and soups, making omelettes	7 - 8
Bringing large amounts of liquid to the boil, searing steaks	9
Heating up water	P

Tab. 5.6 Recommendations for power levels

The specifications provided in the table are standard values. Depending on the cookware and filling quantity, it is recommended to either decrease or increase the power level.

Suitable cookware

i The heating and heat-through time for the base of the cookware as well as the cooking results are significantly influenced by the structure and material of the cookware.



Cookware with this symbol is suitable for induction cooktops.

The cookware used for the induction cooktop must be made of metal, feature magnetic properties and possess a sufficient bottom surface.

Suitable cookware is made of:

- stainless steel with a magnetisable base
- enamelled steel
- cast iron

Appliance	Cooking zone	Minimum diameter
PUXA	front	120 mm
	rear	120 mm
PUXU	front	120 mm
	rear	120 mm
PURA	front	120 mm
	rear	90 mm
PURU	front	120 mm
	rear	90 mm

Tab. 5.7 Minimum cookware diameter

- ▶ Perform a magnet test, if necessary. If a magnet sticks to the base of the utensils, they are normally induction compatible.
- ▶ Pay attention to the cookware bottom. The base of the cookware should not show any sign of curvature. Due to incorrect temperature monitoring of the hob caused by the air gap between the cookware and the temperature sensor underneath the hob, overheating may occur. To avoid

scratching the cooktop, the bottom of the cookware must not have any sharp grooves or sharp edges.

- ▶ Place the cookware (without a mat or similar) directly onto the glass ceramic.

Noises

The following noises may occur in the cookware when using induction cooking zones, depending on the material and the finish of the base:

- Humming may occur when using a high power level. It decreases or disappears if the power level is decreased.
- Crackling or whistling may occur due to bases of cookware being made of different materials (e.g. sandwich base).
- Clicking sounds may occur during electronic switching procedures especially at low power levels.
- Whirring may occur when the cooling fan is switched on. In order to increase the service life of the electronic system, the cooktop is equipped with a cooling fan. The cooling fan switches on automatically if the cooktop is used intensively. You will hear a whirring sound. The cooling fan may continue running after the device has been switched off.

5.5 Overview of features and functions

The BORA X Pure and Pure cooktops with integrated cooktop extractor have the following features and functions:

Features	PUXA	PUXU	PURA	PURU
Electronic power adjustment	✓	✓	✓	✓
Short-time timer (egg timer)	✓	✓	✓	✓
Cooktop extractor functions				
Automatic extractor control	✓	✓	✓	✓
Automatic after-run	✓	✓	✓	✓
Power setting	✓	✓	✓	✓
Filter service display		✓		✓
Cooktop functions				
Automatic heat up function	✓	✓	✓	✓
Pan size recognition	✓	✓	✓	✓
Permanent pan size recognition	✓	✓	✓	✓
Warming function			✓	✓
Variable warming function	✓	✓		
Bridging function	✓	✓		
Automatic bridging function	✓	✓		
Cooking zone timer	✓	✓	✓	✓
Pause function	✓	✓	✓	✓
Power setting	✓	✓	✓	✓
Safety devices				
Childproofing feature	✓	✓	✓	✓
Control lock	✓	✓	✓	✓
Cleaning lock	✓	✓	✓	✓
Residual heat display	✓	✓	✓	✓
Safety shut-down	✓	✓	✓	✓
Overheating protection	✓	✓	✓	✓

Tab. 5.8 Function overview

i You will find instructions on how to use/set the individual functions in the Operation chapter.

Electronic power adjustment

The power levels are adjusted via the operating panel by tapping or swiping movements on the touch slider. Alternatively the power levels can also be set using the touch buttons **+** and **-** above and below the touch slider.

Short-time timer (egg timer)

The short-time timer emits both a visual and an acoustic signal after a time set by the user and offers the function of a conventional egg timer.

5.5.1 Cooktop extractor functions

Automatic extractor control

The extractor power level automatically adjusts itself depending on the current cooktop settings. No manual adjustment of the fan controls is necessary but it is possible. The extractor power is automatically adjusted to the highest power level used on all connected cooking zones.

Function	Power levels									
Cooking level	1	2	3	4	5	6	7	8	9	P
Extractor power	4	4	4	4	5	6	7	8	9	P

Tab. 5.9 Extraction performance and cooking level

- If the power level of a cooking zone is changed, the extractor power is automatically adjusted after a 20 second delay.

Automatic after-run

The cooktop extractor continues to run at a lower level and switches off automatically after a defined time.

The duration of the after-run function can be set in the menu (10, 15 or 20 minutes). The default duration of the after-run function is 20 minutes.

- When the extractor is switched off at the end of cooking the automatic after-run function is activated.
- Once the automatic after-run period has lapsed the cooktop extractor switches itself off.

i BORA expressly recommend use of the cooktop extractor after-run function.

Cooktop extractor power setting

When the power setting is activated, maximum extractor power is available for a predefined time.

This power setting makes it possible to suction away high levels of cooking vapours more quickly. After 5 minutes, the power setting is automatically switched to power level 9.

Filter service display

The cooktop extractor filter service indicator is automatically activated when the end of the activated charcoal filter service life is reached (only in recirculation mode).

- F is displayed in the multi-function display.
- The filter service display is shown every time the cooktop extractor is switched on and remains active until the filter has been changed and the filter service display has been reset (see Operation chapter).

- The cooktop extractor can still be operated without limitations.

i The components of the grease filter require regular cleaning regardless of the filter service indicator (see Cleaning and Maintenance chapter).

5.5.2 Cooktop functions

Automatic heat up function

When the automatic heat up function is activated, the cooking zone works at full power for a certain time and is then automatically reset to the previously set level.

Power level (continuous cooking level)	Cooking duration in min:sec
1	00:40
2	01:00
3	02:00
4	03:00
5	04:20
6	07:00
7	02:00
8	03:00

Tab. 5.10 Heating time overview

Pan size recognition

The cooking zone recognises the size of the cookware automatically and only targets the energy at that area. It also recognises cookware that is unsuitable or too small or if there is no cookware present.

A cooking zone is not working if \cup / \cup are alternated in the display. This happens if...

- ...it is switched on without cookware or with unsuitable cookware.
 - ...the base diameter of the cookware is too small.
 - ...the cookware is removed from a switched-on cooking zone.
- If no pot is recognised 10 minutes after setting a power level, the cooking zone will switch off automatically.

Permanent pan size recognition

The cooking zone automatically recognises cookware and switches the corresponding operating panel on: Manual activation of the cooking zone is not necessary (see Operation chapter, User menu).

One-level warming function

On the warming level, meals that have already been cooked can be kept warm at a lower temperature without any risk of burning.

- The maximum duration for the warming function is preset to 8 hours.

Variable warming function (3 levels)

Depending on the application or food used, it is possible to choose from 3 warming levels at different temperatures:

Warming level	Symbol	Temperature
1 (melting)	-	≈ 42 °C
2 (keeping warm)	-	≈ 74 °C
3 (simmering)	≡	≈ 94 °C

Tab. 5.11 Warming levels

- The maximum duration for the warming function is limited to 8 hours.

i In practice the temperatures of the warming levels may vary slightly as they are influenced by the cookware, the amount of food and the different heating technologies. The temperatures can also vary due to the influence of the cooktop extractor.

Bridging function

With the bridging function two cooking zones can be combined to form one large cooking zone. The power for the combined zones is then adjusted by a single operating control. Power adjustment takes place simultaneously (both cooking zones are operated on the same power level).

The bridging function is suitable for heating food, e.g. in a roaster.

Automatic bridging function

If a large enough cooking pot or roaster is placed on the two cooking zones that are one behind the other, they will automatically be combined to form one large cooking zone. It is not necessary to activate the bridging function manually (see Operation chapter, Customer menu).

Cooking zone timers (automatic cut-off)

The automatic cut-off function automatically switches off the selected cooking zone once a preset time has lapsed.

The timer function can also be used on several cooking zones at the same time (multi-timer).

Pause function

With the pause function all cooking zones can be quickly and easily deactivated temporarily. When the function is cancelled, operation resumes at the original settings.

The cooking session can be paused for max. 10 minutes.

Once 10 minutes have lapsed, the cooking session is automatically ended.

Cooktop power setting

When the power setting is activated, maximum cooking zone power is available for a predefined time.

- The available power is focused on the selected cooking zone, meaning that the max. power of the second cooking zone on that side is automatically and temporarily reduced:
 - If the front cooking zone is operated using the power setting, a maximum power level of 7 can be selected in the rear cooking zone.
 - If the rear cooking zone is operated using the power setting, a maximum power level of 7 can be selected in the front cooking zone (max. power level 8 on Pure).

- If the power level selected for the second cooking zone is too high, P will blink three times and the cooking zone will switch back to power level 9.
- After 5 minutes, the cooking zone is automatically switched back to power level 9.

i Never heat up oil, fat and the like on the power setting. The bottom of the pan can overheat due to the high power output.

5.6 Safety devices

Childproofing feature

The childproofing feature prevents the appliance from being switched on accidentally or without permission.

Control lock

The control lock prevents the current settings from being changed accidentally or without permission.

- If the control lock is active, the symbol lights up 
- The functions are locked and the indicators on the display are dimmed (exception: On/Off touch button).

Cleaning lock (wipe function)

The cleaning lock prevents settings from being changed when wiping the operating panel during a cooking session. When activated, the operating panel is locked for 10 seconds. The remaining time is displayed. All appliance settings remain unchanged in the meantime.

Residual heat display

If a cooking zone is still hot after switching off, there is a risk of burns or fire. While H is displayed for a cooking zone (residual heat display), do not touch the cooking zone or place any heat-sensitive objects on top of it.

- H shown at 100% brightness: very high temperature
 - H shown at 50% brightness: high temperature
- The display goes out after a sufficient cooling time (temperature < 55 °C).

5.6.1 Safety shut-down

Cooktop extractor

The cooktop extractor switches to automatic mode after 120 min if there has been no input or changes to the power level (see Automatic extractor function).

Cooktops

Each cooking zone is automatically switched off after a predefined operating time in which the power level has not been changed. 3 levels are available to set the time until safety shut-down.

- Safety shut-down is preset to level 2.
- The level can be changed in the user menu.

Power levels	Safety shut-down after hrs:min		
	Level 1	Level 2	Level 3
1	12:00	08:24	06:00
2	10:00	06:24	04:00
3	09:00	05:12	02:30
4	08:00	04:12	02:00
5	06:00	03:18	01:30
6	04:00	02:12	01:00
7	04:00	02:12	01:00
8	03:00	01:48	00:45
9	02:00	01:18	00:30
P	00:05	00:05	00:05

Tab. 5.12 Safety shut-down for power levels

Warming level	Safety shut-down after hrs:min		
	Level 1	Level 2	Level 3
 1	12:00	08:00	04:00

Tab. 5.13 Safety shut-down for the warming level

- Switch the cooking zone back on if you want to put the cooking zone back into operation.

5.6.2 Overheating protection

- i** If the cooktop overheats, the power is reduced or the cooktop is switched off completely.

The device is fitted with overheating protection. The overheating protection can be triggered if:

- Cookware is heated up empty.
 - Oil or fat is heated on high power.
 - A hot cooking zone is switched on again after a power cut.
- Whilst the overheating protection is active, one of the following steps is taken:

- The activated power setting is switched back to the previous level.
- The power setting P can no longer be switched on.
- The power level set is reduced.
- The cooktop switches off completely.

After a sufficient cooling period, the cooktop can be used again in full.

6 Installation

- ▶ Observe all safety and warning information (see the “Safety” chapter).
- ▶ Follow the enclosed manufacturer’s information

6.1 General installation instructions

- i** The power supply cable must be provided by the customer.
- i** The appliance must not be installed above cooling devices, dishwashers, stoves, ovens, washing machines or dryers.
- i** The contact surface of the worktops and wall sealing strips must be made of a heat-resistant material (up to approx. 100 °C).
- i** Worktop cut-outs must be moisture-sealed using suitable means and, where necessary, fitted with a thermal insulator.
- i** The integrated cooktop extractor must not be used with other cooktops.

General installation instructions for cooktops

- i** To ensure that the cooktops perform optimally at all times, there must be sufficient ventilation beneath the cooktops.
 - i** The performance of the cooktops is affected or the cooktops overheat if the warm air beneath the cooktops cannot escape.
 - i** If a cooktop overheats, the power is automatically reduced or the cooktop is switched off completely (see “Overheating protection”).
 - i** If cable protection (false floor) is planned beneath the appliance, this must be fitted so it does not obstruct ventilation.
- ▶ Make sure that the area below the cooktop has a sufficient air supply.

6.1.1 Simultaneous operation of the cooktop extractor in the exhaust air mode and a fireplace dependent upon the air supply in the room

- i** National and regional laws and regulations must be observed with regard to the exhaust duct design.
- i** A sufficient air supply must be ensured.

Fireplaces that depend on the air in the room (e.g. gas, oil, wood or coal-fired heaters, continuous-flow water heaters, instantaneous water heaters) draw in air from the room in which they are installed and release the exhaust fumes into the outside air via an exhaust system (e.g. chimney).

If the cooktop extractor is used in exhaust air mode, it draws in air from the room in which it is installed as well as from neighbouring rooms. If there is insufficient air supply, low pressure will occur. Toxic gases could be drawn out of the chimney or extraction ducting and back into the room.

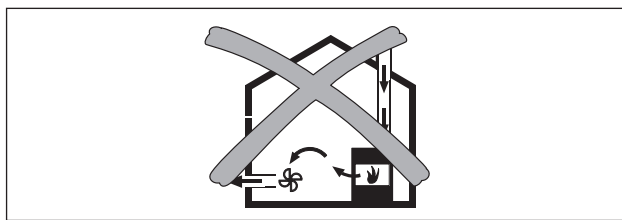

Fig. 6.1 Exhaust air installation – not permitted

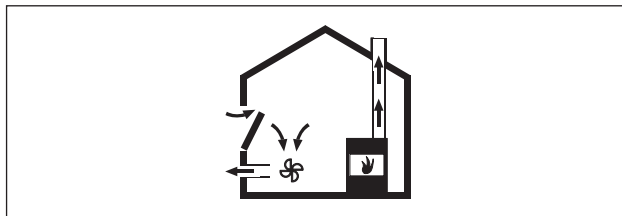

Fig. 6.2 Exhaust air installation – correct

- ▶ If simultaneously operating both a fireplace and the cooktop extractor in the same room, ensure that:
 - the maximum low pressure is 4 Pa (4 x 10⁻⁵ bar);
 - a safety device (e.g. window contact switch, low pressure warning device) is used to ensure that a sufficient supply of fresh air is guaranteed;
 - the exhaust air is not be ducted into a chimney that is used for exhaust gases of devices operated with gas or other combustibles;
 - the installation is checked and approved by an authorised certified engineer (e.g. heating engineer).
- i** If the cooktop extractor is used exclusively in recirculation mode, operation with an open fireplace is possible without any additional safety measures.

6.1.2 Home In module PUHIM (optional)

Via this additional interface it is possible to establish a connection to other systems and, for example, a window contact switch or low pressure warning device can be connected. The module is to be integrated in the cooktop.

i The BORA Pure Home In module PUHIM is available as an accessory.

i The BORA window contact switch UFKS is available as an accessory.

6.2 Scope of delivery

Scope of delivery: PUXA, PUXU, PURA, PURU	Quantity
Cooktop with integrated cooktop extractor	1
Air inlet nozzle	1
Stainless steel grease filter	1
Operating and installation instructions	1
Installation clamps	4
Sealing tape	1
Height adjustment plate set	1
Glass ceramic scraper	1
Bag containing various small parts for assembly	1
Additional scope of delivery: PURU, PUXU	
Activated charcoal filter	1
Template for back wall cut-out	1

Tab. 6.1 Scope of delivery

6.2.1 Checking the scope of delivery

- ▶ Make sure the delivery is complete and check it for damage.
- ▶ If there are any missing or damaged parts, please notify BORA After Sales Service immediately.
- ▶ Do not under any circumstances install parts which are damaged.
- ▶ Dispose of transport packaging in the proper manner (see the "Decommissioning, disassembly and disposal" chapter).

6.3 Tool and aids

The following special tools are required to correctly install the cooktop:

- Compass saw or hand saw
- Drilling template for cut-out on rear wall PURU (included in scope of delivery)
- Torx 20 screwdriver
- Black, heat-resistant silicone sealant

6.4 Assembly instructions

6.4.1 Required clearance distances

- ▶ Observe the required clearance distances.

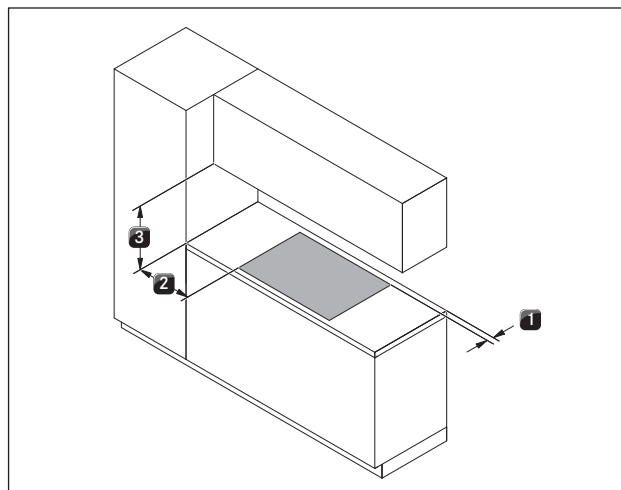

Fig. 6.3 Required clearance distances

- [1] Minimum clearance of 50 mm between the worktop cut-out and the rear edge of the worktop.
- [2] Minimum clearance of 300 mm from the left and right of the worktop cut-out to the adjacent cabinet or wall.
- [3] Minimum clearance of 600 mm between the worktop and the wall unit. A minimum clearance of 1000 mm is recommended for ergonomic reasons.

6.4.2 Minimum unit dimensions for X Pure (PUXA, PUXU)

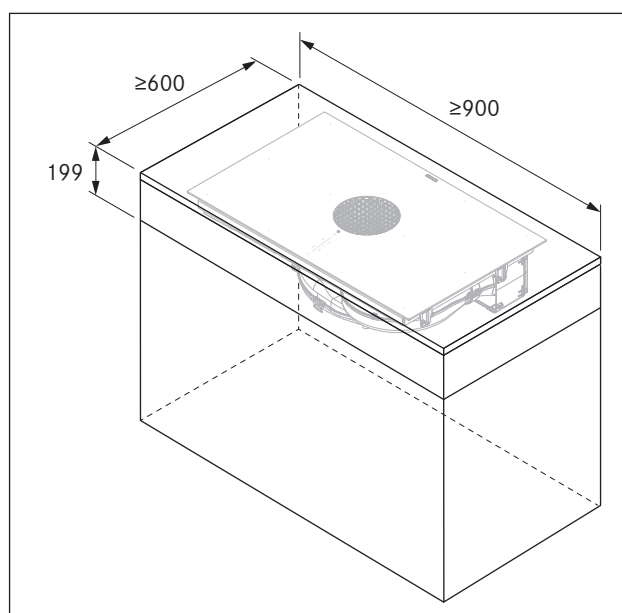

Fig. 6.4 X Pure minimum unit dimensions

6.4.3 Minimum unit dimensions for Pure (PURA, PURU)

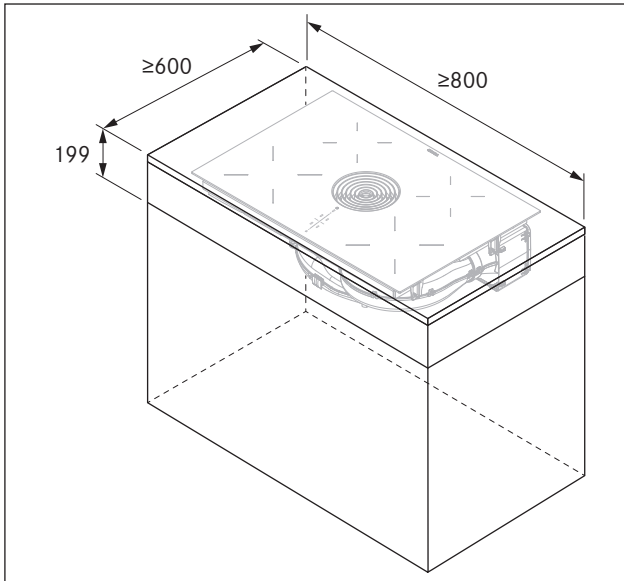

Fig. 6.5 Pure minimum unit dimensions

6.5 Worktop cut-out

i All dimensions are shown from the front edge of the front cover.

Worktop overhang

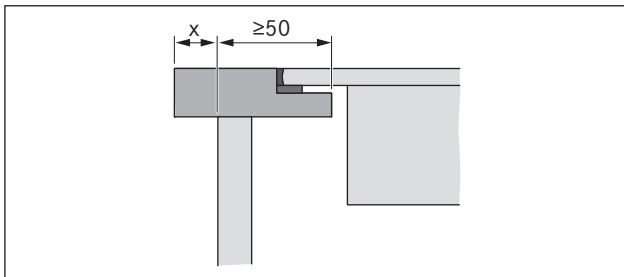

Fig. 6.6 Worktop overhang

- ▶ Please note the worktop overhang x when creating the worktop cut-out. Applies to flush installation and surface mounting.
- ▶ Create the worktop cut-out taking into account the specified cut-out dimensions.
- ▶ Make sure that the cut surfaces of the worktops are properly sealed.
- ▶ Comply with the instructions of the worktop manufacturer.

6.5.1 X Pure cut-out dimensions (PUXA, PUXU)

X Pure flush installation (PUXA, PUXU)

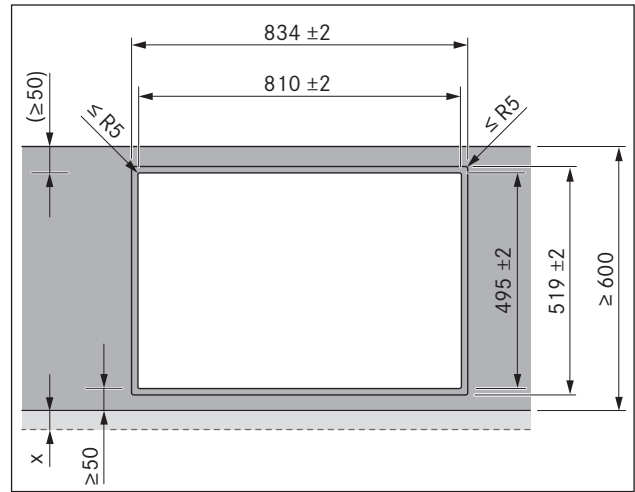

Fig. 6.7 Cut-out dimensions for flush installation

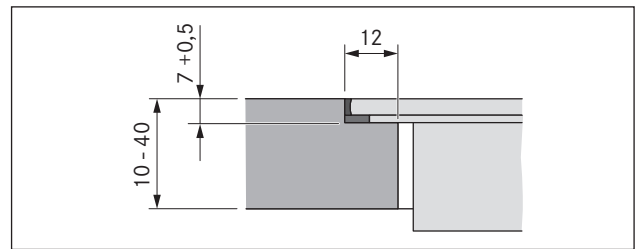

Fig. 6.8 Rebate dimensions for flush installation

X Pure surface mounting (PUXA, PUXU)

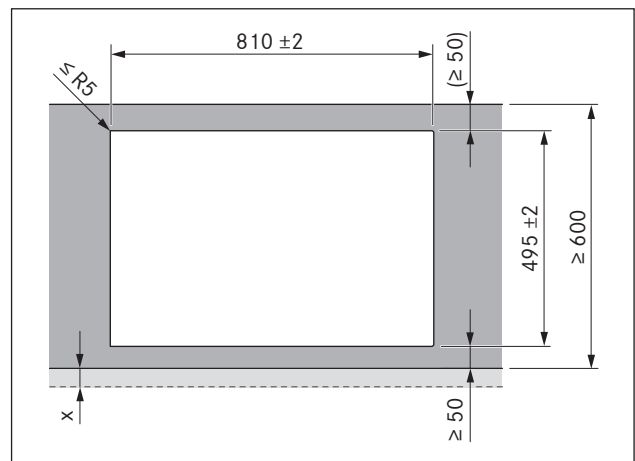

Fig. 6.9 Cut-out dimensions for surface mounting

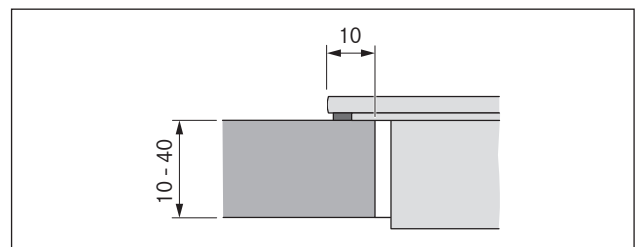

Fig. 6.10 Overlay dimensions for surface mounting

6.5.2 Pure cut-out dimensions (PURA, PURU)

Pure flush installation (PURA, PURU)

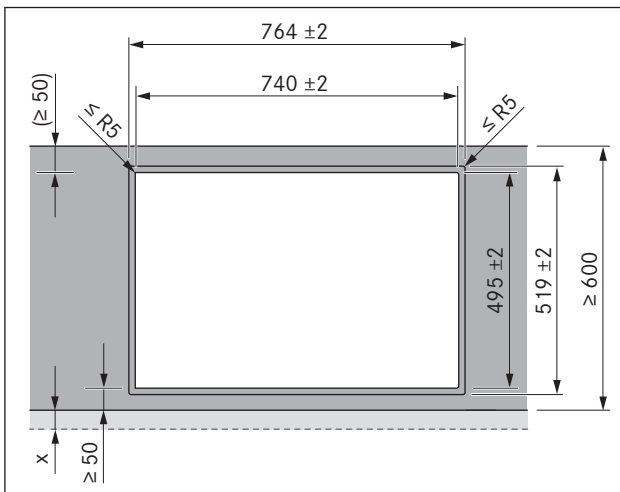

Fig. 6.11 Cut-out dimensions for flush installation

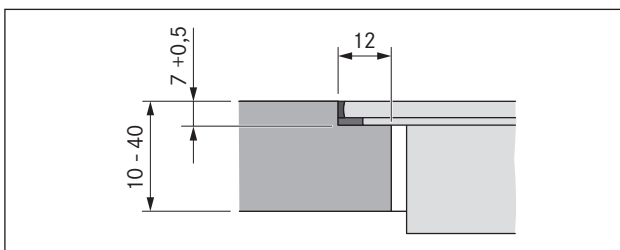

Fig. 6.12 Rebate dimensions for flush installation

Pure surface mounting (PURA, PURU)

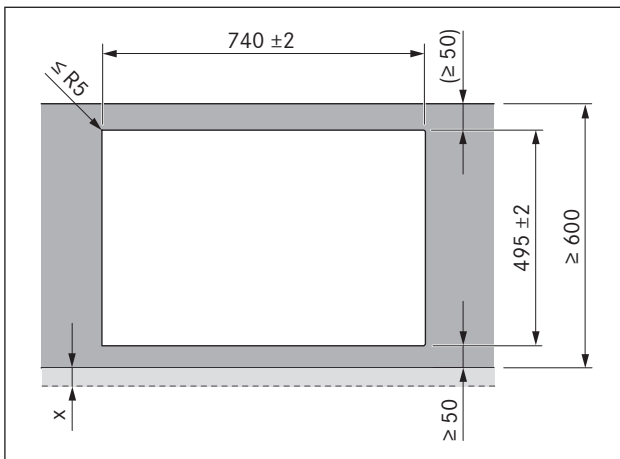

Fig. 6.13 Cut-out dimensions for surface mounting

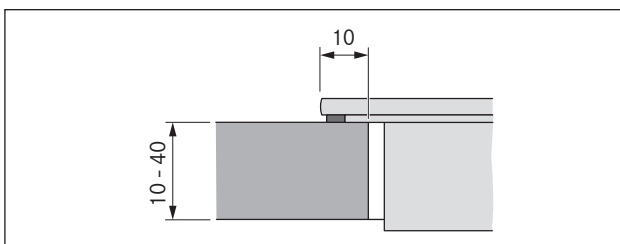

Fig. 6.14 Overlay dimensions for surface mounting

6.6 Installing the appliance in exhaust air mode (PUXA, PURA)

- i** National and regional laws and regulations must be observed with regard to the exhaust duct design.
- i** A sufficient air supply must be ensured.
- i** The exhaust air must be directed to the outside by appropriate exhaust air ducts.
- i** The minimum cross-section of the air ducts must be 176 cm², which equates to a round pipe with a diameter of 150 mm or the BORA Ecotube duct system.
- i** As a general rule, with the built-in fan, a length of duct of up to 6 metres with six 90° bends, 8 metres with four 90° bends or 10 metres with two 90° bends can be installed.
- i** Not compatible with BORA Universal fans.
- i** Planning instructions for the installation of the exhaust air ducts are provided in the BORA ventilation handbook.

6.6.1 Preparing kitchen units for the exhaust air model

- Cross bars on the kitchen unit in the area of the worktop cut-out may need to be removed.
- In the case of thin worktops, there must be a sufficiently rigid support plate on the unit.
- The back wall of the floor unit must be adapted for the exhaust air duct.
- A minimum clearance of 120 mm between the back wall of the unit and an adjacent kitchen unit or room wall must be observed for the air duct.
- No false floor is necessary below the cooktop. If cable protection (false floor) is planned, the following must be taken into account:
 - It must be fitted in such a way that it can be removed from below for maintenance work.
 - To ensure sufficient cooktop ventilation, a minimum distance of 15 mm to the bottom edge of the cooktop is to be observed.
- The drawers and/or shelves in the floor unit must be removable.
- For correct installation, the drawers of the floor unit must be shortened depending on the installation situation.

Installation dimensions

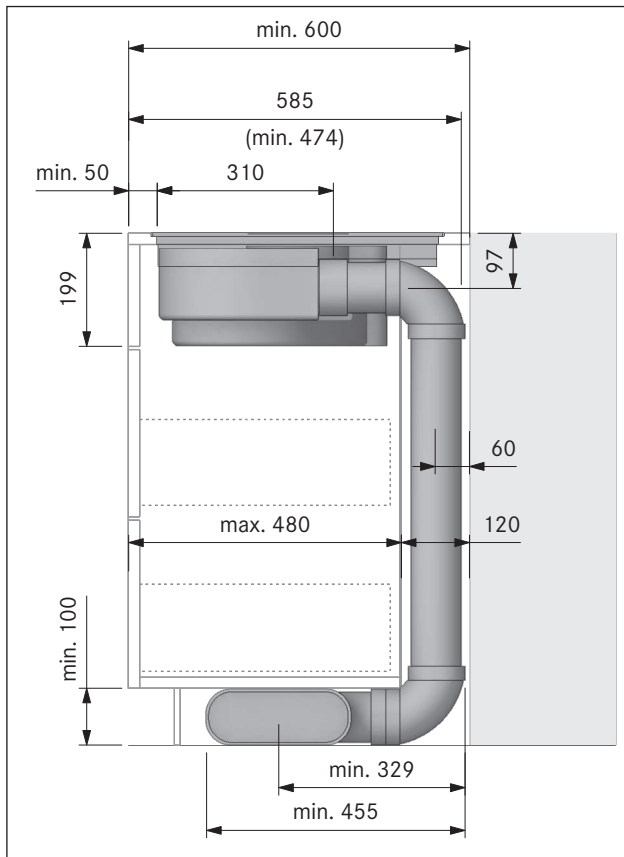

Fig. 6.15 Installation dimensions for exhaust air, worktop depth 600 mm

Adjusting the back wall of the unit

- ▶ Before installation, check the suitability of the floor unit with regard to the necessary installation dimensions for the appliance and the planned duct system.
- ▶ If necessary, adjust the position of the back wall according to the required installation dimensions.

6.6.2 Preparing the cooktop

Attaching the sealing tape

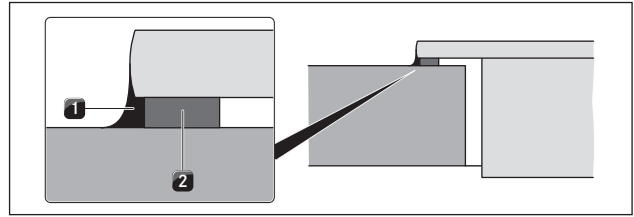

Fig. 6.16 Sealing tape in the case of surface mounting

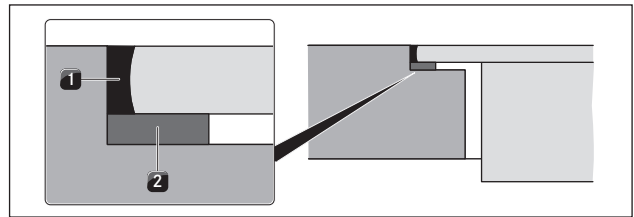

Fig. 6.17 Sealing tape in the case of flush installation

- [1] Black, heat-resistant silicone sealant
- [2] Sealing tape

- ▶ In the case of surface mounting, attach the enclosed sealing tape [2] around the outer edges of the underside of the cooktop. Do not leave any gaps.
- ▶ In the case of flush installation, attach the enclosed sealing tape [2] to the horizontal cutting edge in the worktop cut-out, even if you are sealing the cooktop with a silicone sealing compound [1] or similar.

Fitting the installation clamps

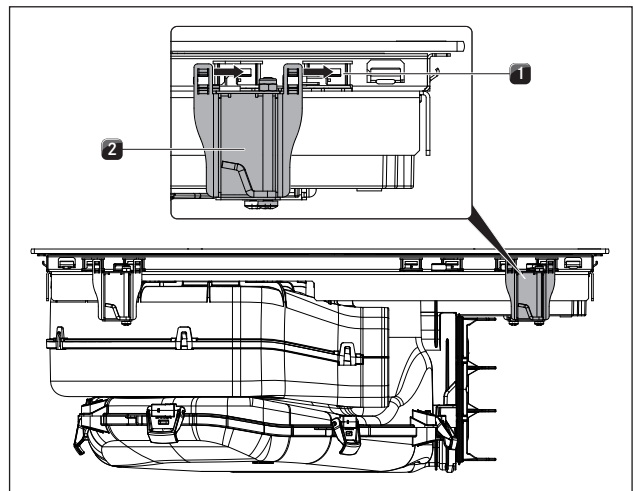

Fig. 6.18 Fitting the installation clamps

- [1] Retaining brackets
- [2] Installation clamps

i 2 installation clamps must be fitted to each side of the cooktop.

- ▶ Push 2 installation clamps [2] onto each side of the cooktop until they come to a stop in the retaining brackets [1] provided.

6.6.3 Inserting the cooktop

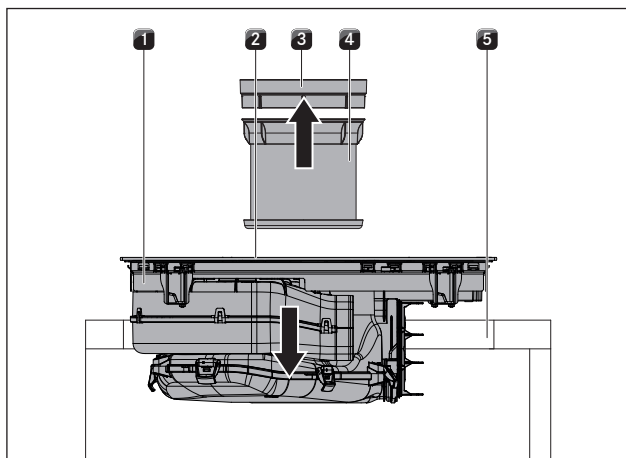

Fig. 6.19 Inserting the cooktop

- [1] Cooktop
- [2] Inlet opening
- [3] Air inlet nozzle
- [4] Stainless steel grease filter
- [5] Worktop cut-out

- ▶ Before inserting the cooktop, remove the air inlet nozzle [3] and the stainless steel grease filter [4].
- ▶ Use the inlet opening [2] as a handle during insertion.
- ▶ Keep the cooktop [1] straight as you lift it into the worktop cut-out [5].
- ▶ Insert the cooktop [1] into the centre of the worktop cut-out [5].
- ▶ Precisely align the cooktop.

Information regarding surface mounting:

- ▶ make sure that the cooktop sealing tape is flat against the worktop.

Information regarding flush installation:

- ▶ make sure that the cooktop sealing tape is well sealed all the way round.

Height adjustment plates for flush installation (optional)

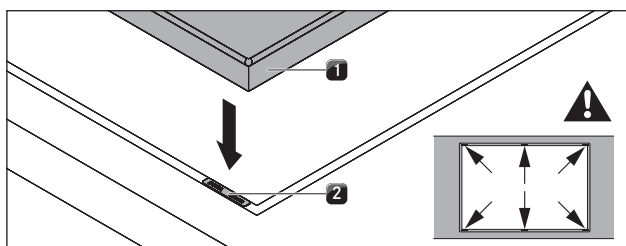

Fig. 6.20 Inserting height adjustment plates

- [1] Cooktop
- [2] Height adjustment plate

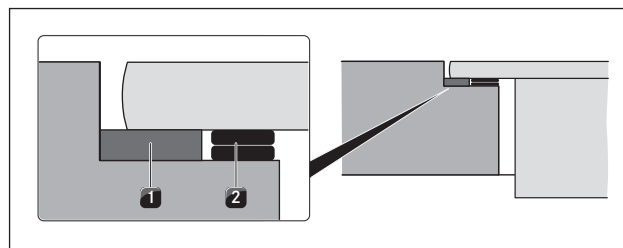

Fig. 6.21 Height adjustment plates

- [1] Sealing tape
- [2] Optional height adjustment plates

- The height adjustment plates are self-adhesive to prevent slipping during installation.
- ▶ If necessary, lay the height adjustment plates [2] underneath.
- ▶ Place the height adjustment plates next to the sealing tape [2].

6.6.4 Securing the cooktop

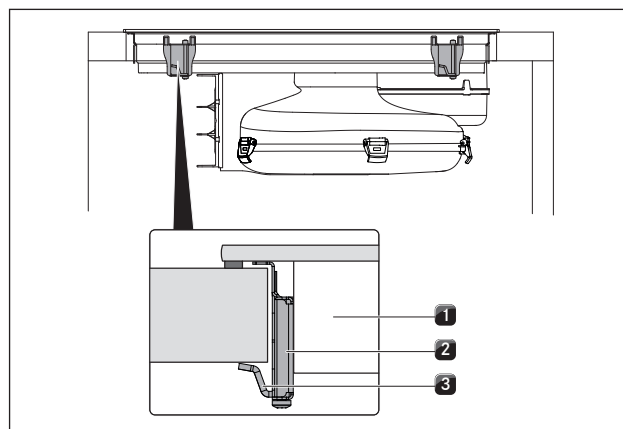

Fig. 6.22 Securing the cooktop in the middle

- [1] Cooktop
- [2] Installation clamp
- [3] Fixing bracket

- ▶ Secure the cooktop to the worktop [1] with the fixing bracket [3] on the installation clamp [2].
- ▶ Tightening torque: max. 2.2 Nm.

6.6.5 Connecting the device to the duct system

- i** The duct system must be fitted to the device free of load and with the power supply switched off.
- i** For correct installation, the drawers of the floor unit must be shortened depending on the installation situation.
- i** When attaching the seals, ensure that an airtight seal with the connection duct piece is created when the seals are compressed.

- ▶ Use only BORA Ecotube duct parts.
- ▶ Do not use flexible or fabric hoses.

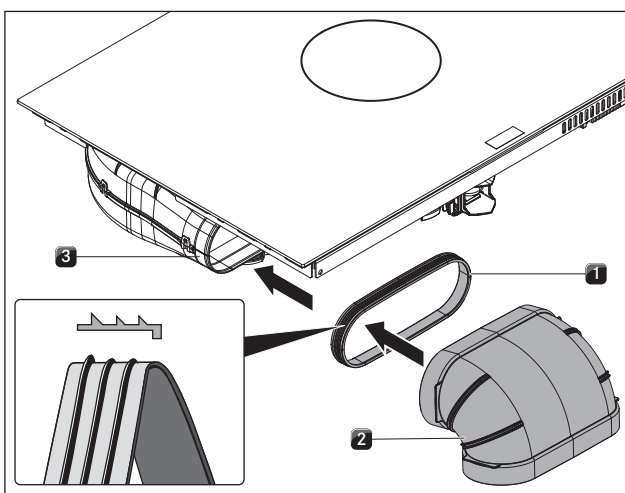

Fig. 6.23 Connecting the duct system

- [1] Seal
- [2] Duct part
- [3] Exhaust opening

- ▶ Pull the seal [1] onto the exhaust opening [3] on the appliance. The seal [1] will need to be stretched slightly.
- ▶ Push the duct part to be connected [2] with the coupling onto the exhaust opening [3] with the seal [1].
- ▶ Ensure that the seal [1] is not displaced.

6.7 Installing the recirculation model (PUXU, PURU) of the appliance

6.7.1 Recirculation of air from the kitchen unit

In the case of recirculation appliances, a return flow aperture of $\geq 500 \text{ cm}^2$ must be provided in the kitchen unit to guide the clean recirculated air out of the unit and back into the room. The return flow aperture can be created above a shortened plinth with a slatted plinth with at least the minimum opening cross-section can also be used.

- i** A return flow aperture $\geq 500 \text{ cm}^2$ must be provided in the kitchen units.

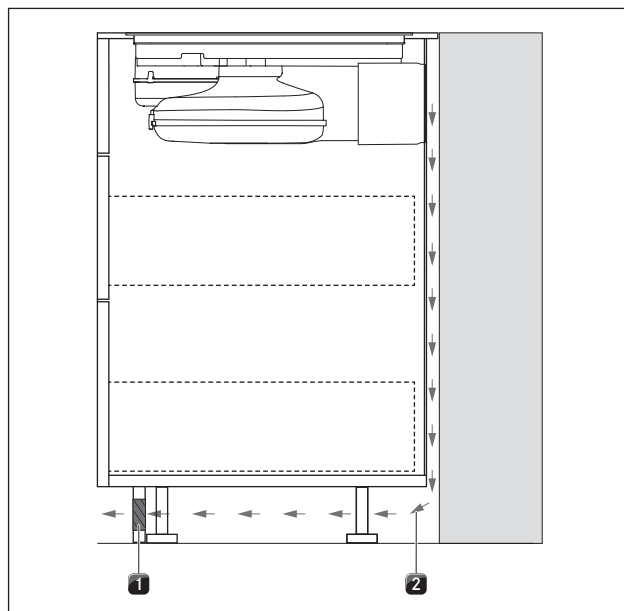

Fig. 6.24 Return flow aperture in the plinth area

- [1] Return flow aperture in the plinth (total cross-section of the aperture $\geq 500 \text{ cm}^2$)
- [2] Return flow of recirculated air

- ▶ Decrease the height of the plinth panel or create corresponding openings in the plinth.

6.7.2 Installation variants (A and B) for recirculation appliances

There are 2 installation variants for recirculation appliances PUXU and PURU: A and B

A: floor unit with continuous back wall

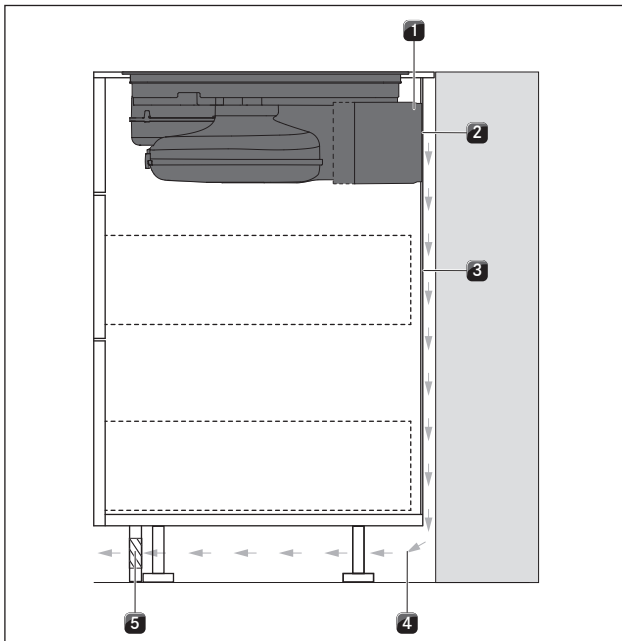

Fig. 6.25 Installation variant with continuous back wall

- [1] Air cleaning box
- [2] Connection with the back wall
- [3] Continuous back wall in the unit
- [4] Return flow of recirculated air
- [5] Return flow aperture

The recirculated air [4] is guided through the connection with the back wall [2] of the air cleaning box [1] directly behind the rear wall of the unit [3]. The recirculated air goes back in to the room through the return flow aperture [5].

For installation purposes, this means that:

- no false floor is necessary below the cooktop.
- There must be a cut-out in the back wall.

B: floor unit with false floor under the cooktop

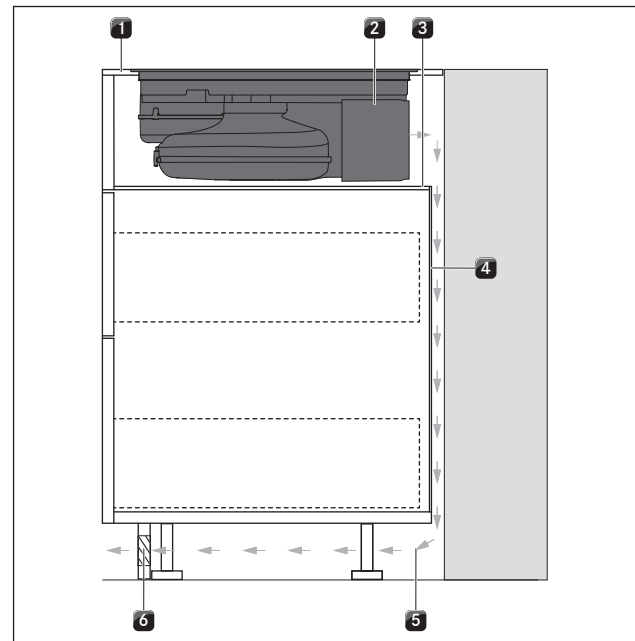

Fig. 6.26 Installation variant with false floor

- [1] Worktop
- [2] Air cleaning box
- [3] False floor
- [4] Back wall of unit
- [5] Return flow of recirculated air
- [6] Return flow aperture

The recirculated air [5] is blown into the free space between the worktop [1] and the false floor [3] (the air cleaning box [2] does not connect with the rear wall). The recirculated air goes behind the rear wall of the unit [4] and through the return flow aperture [6] back into the room.

For installation purposes, this means that:

- a false floor is necessary below the cooktop.
- There does not need to be a cut-out in the back wall of the unit.

6.7.3 Preparing kitchen units for installation variant A (floor unit with continuous back wall)

- Cross bars on the kitchen unit in the area of the worktop cut-out may need to be removed.
- In the case of thin worktops, there must be a sufficiently rigid support plate on the unit.
- The floor unit must have a continuous back wall so that the recirculated air is not directed into the front furniture body compartment.
- There must be a cut-out in the back wall.
- A minimum clearance of 25 mm between the back wall of the unit and an adjacent kitchen unit or room wall must be observed for the return flow of the recirculated air.
- No false floor is necessary below the cooktop. If cable protection (false floor) is planned, the following must be taken into account:
 - it must be fitted in such a way that it can be removed for maintenance work.
 - To ensure sufficient cooktop ventilation, a minimum distance of 15 mm to the bottom edge of the cooktop is to be observed.
- The drawers and/or shelves in the floor unit must be removable.
- For correct installation, the drawers of the floor unit must be shortened depending on the installation situation.

Installation dimensions

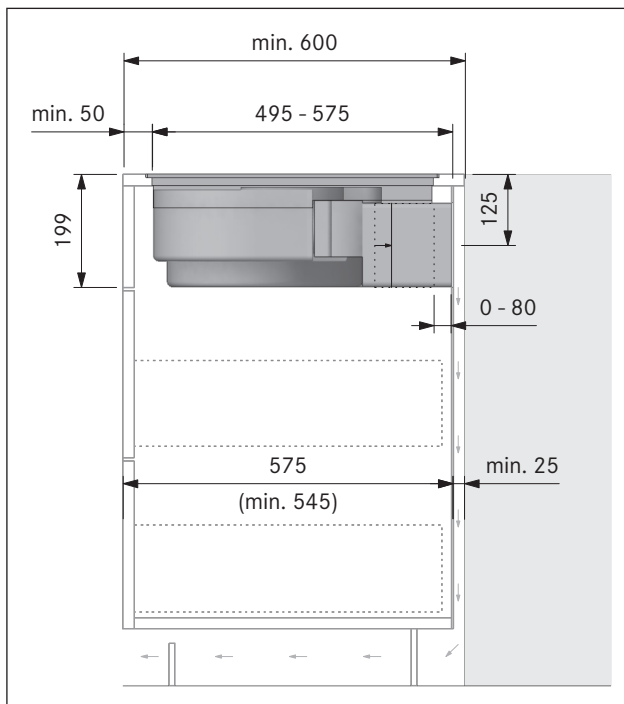

Fig. 6.27 Installation dimensions in the case of recirculated air, installation variant A

Adjusting the back wall of the unit

- ▶ Adapt the back wall according to the required installation dimensions.
- ▶ If necessary, move the back wall.
- ▶ If necessary, extend the height of the back wall so that the unit is closed to the front.

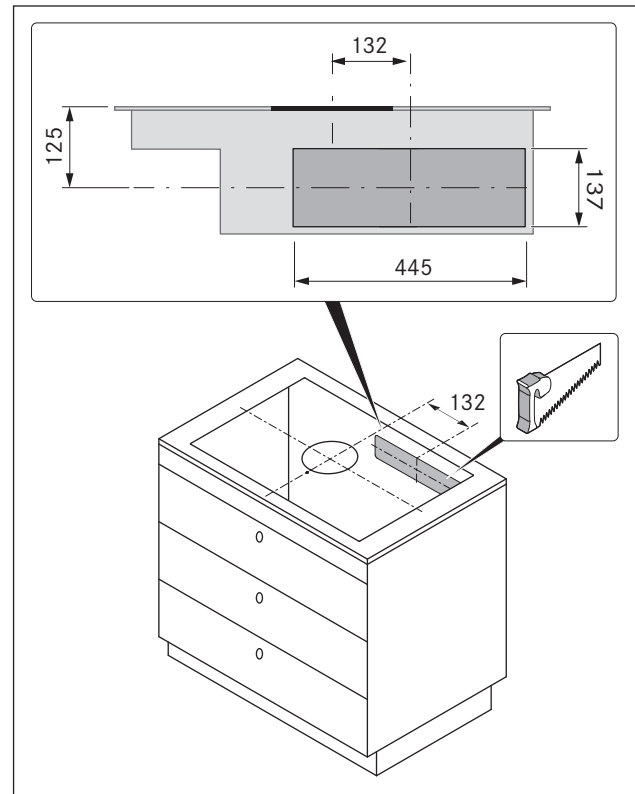

Fig. 6.28 Return flow aperture cut-out

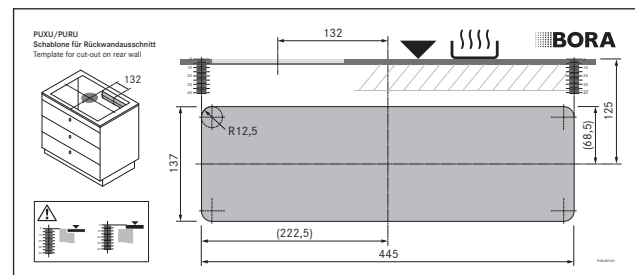

Fig. 6.29 Template for back wall cut-out

- ▶ Position the template on the back wall of the unit with the help of the markings and instructions.

i Centre of cut-out (horizontal): 125 mm from the top edge of the cooktop. Centre of cut-out (vertical): offset 132 mm from the centre of the cooktop.

- ▶ Draw the bore hole accordingly with the aid of the drilling template provided.
- ▶ Saw out the return flow aperture.

6.7.4 Preparing kitchen units for installation variant B (floor unit with false floor under the cooktop)

- Cross bars on the kitchen unit in the area of the worktop cut-out may need to be removed.
- In the case of thin worktops, there must be a sufficiently rigid support plate on the unit.
- A false floor must be provided for under the cooktop:
 - It must be fitted in such a way that it can be removed for maintenance work.
 - To ensure sufficient cooktop ventilation, a minimum distance of 15 mm to the bottom edge of the cooktop is to be observed.
- The back wall of the unit must be flush with the false floor so that the recirculating air is not directed into the front of the unit.
- A minimum clearance of 25 mm between the back wall of the unit and an adjacent kitchen unit or room wall must be observed for the return flow of the recirculated air.
- The drawers and/or shelves in the floor unit must be removable.
- For correct installation, the drawers of the floor unit must be shortened depending on the installation situation.

Installation dimensions

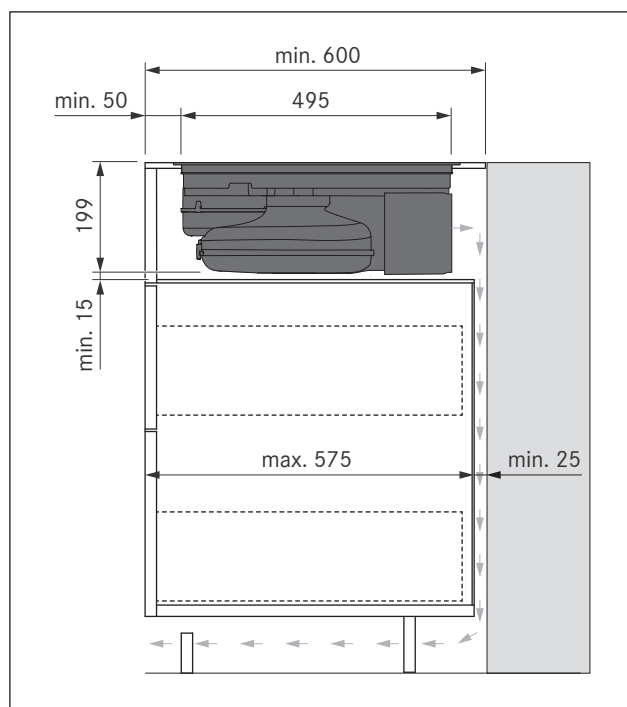

Fig. 6.30 Installation dimensions for recirculation installation variant B, depth of worktop 600 mm

Adjusting the back wall of the unit

- ▶ Adapt the back wall according to the required installation dimensions.
- ▶ If necessary, move the back wall.
- ▶ Adjust the height of the rear wall to the false floor so that they are flush with one another.

6.7.5 Preparing the cooktop

Attaching the sealing tape

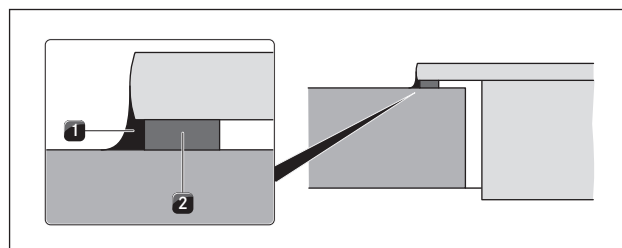

Fig. 6.31 Sealing tape in the case of surface mounting

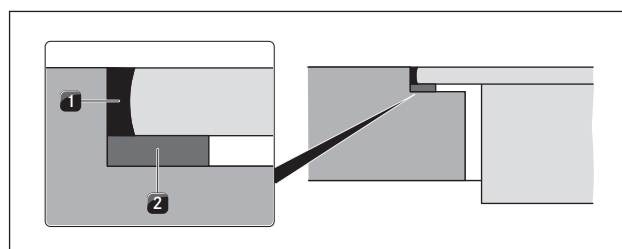

Fig. 6.32 Sealing tape in the case of flush installation

- [1] Black, heat-resistant silicone sealant
- [2] Sealing tape

- ▶ In the case of surface mounting, attach the enclosed sealing tape [2] around the outer edges of the underside of the cooktop. Do not leave any gaps.
- ▶ In the case of flush installation, attach the enclosed sealing tape [2] to the horizontal cutting edge in the worktop cut-out, even if you are sealing the cooktop with a silicone sealing compound [1] or similar.

Fitting the installation clamps

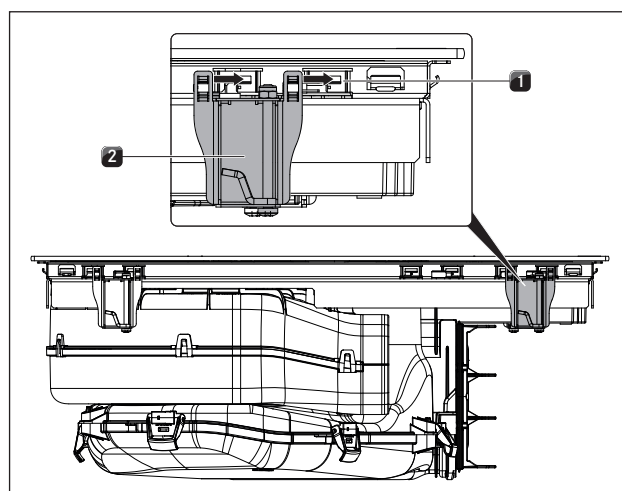

Fig. 6.33 Fitting the installation clamps

- [1] Retaining brackets
- [2] Installation clamps

i 2 installation clamps must be fitted to each side of the cooktop.

- ▶ Push 2 installation clamps [2] onto each side of the cooktop until they come to a stop in the retaining brackets [1] provided.

6.7.6 Extending the telescopic pull-out of the air cleaning box (PULBTA)

If the depth of the worktop exceeds 675 mm in installation variant A, the telescopic pull-out of the air cleaning box must be extended using the accessory PULBTA.

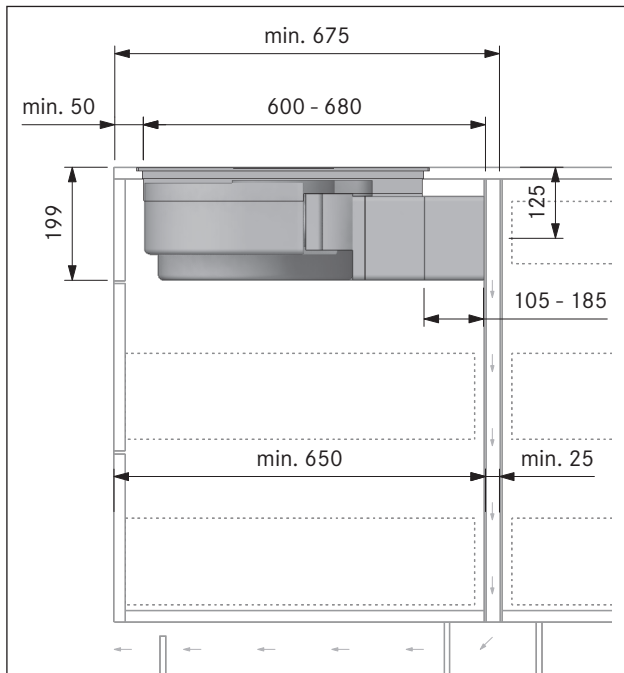

Fig. 6.34 Installation dimensions for recirculation installation variant A, depth of worktop 675 mm and over

- i** The telescopic pull-out is used to connect the duct to the back wall of the kitchen unit. This can be used to flexibly bridge the gap between the cooktop and the rear wall of the kitchen unit (max. 80 mm). If necessary, the telescopic pull-out can be extended by a further 105 mm using the extension PULBTA (available as an accessory).

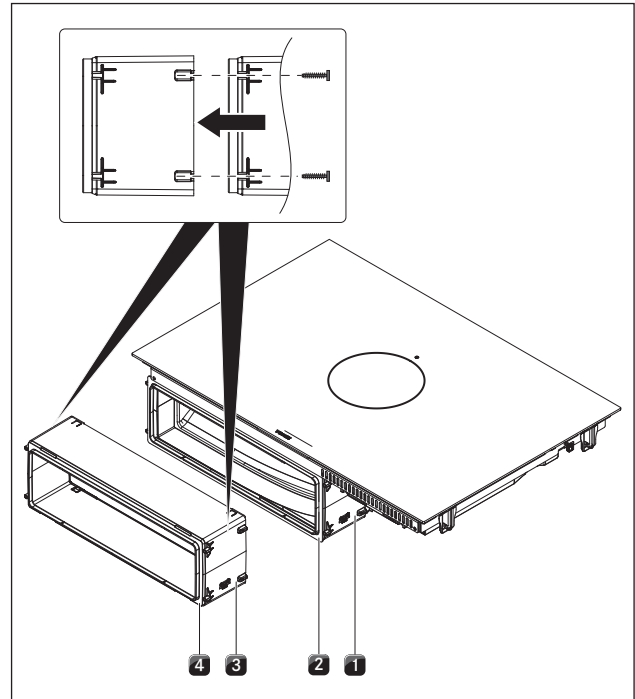

Fig. 6.35 Extending the telescopic pull-out.

- [1] Air cleaning box with telescopic pull-out
- [2] Telescopic pull-out adhesive tape
- [3] Telescopic pull-out extension PULBTA
- [4] Adhesive tape for telescopic pull-out extension PULBTA

- ▶ Remove the protective film from the adhesive tape [2] on the front of the telescopic pull-out [1].
- ▶ Attach the extension PULBTA [3] (available as an accessory including screws for attachment) to the telescopic pull-out [1].
- ▶ Remove the protective film from the adhesive tape [4] on the front of the extension PULBTA [3].

6.7.7 Inserting the cooktop

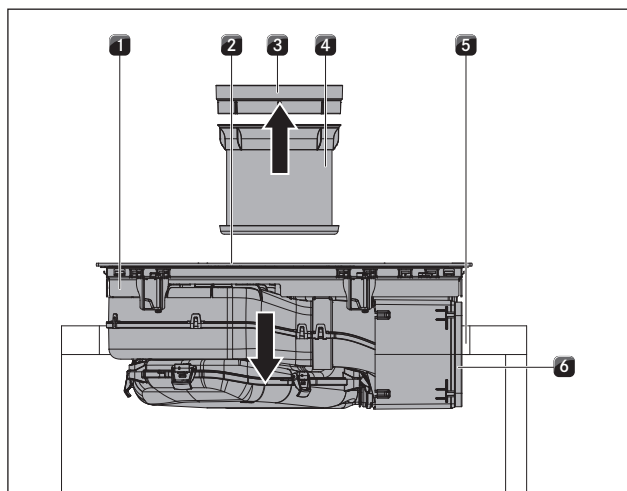

Fig. 6.36 Positioning the cooktop in the centre

- [1] Cooktop
- [2] Inlet opening
- [3] Air inlet nozzle
- [4] Stainless steel grease filter
- [5] Worktop cut-out
- [6] Adhesive tape

- ▶ Before inserting the cooktop, remove the air inlet nozzle [3] and the stainless steel grease filter [4].
- ▶ Remove the protective film from the adhesive tape [6] on the front of the telescopic pull-out.
- ▶ Use the inlet opening [2] as a handle during insertion.
- ▶ Keep the cooktop [1] straight as you lift it into the worktop cut-out [5].
- ▶ Insert the cooktop [1] into the centre of the worktop cut-out [5].
- ▶ Precisely align the cooktop.

Information regarding surface mounting:

- ▶ make sure that the cooktop sealing tape is flat against the worktop.

Information regarding flush installation:

- ▶ make sure that the cooktop sealing tape is well sealed all the way round.

Height adjustment plates for flush installation (optional)

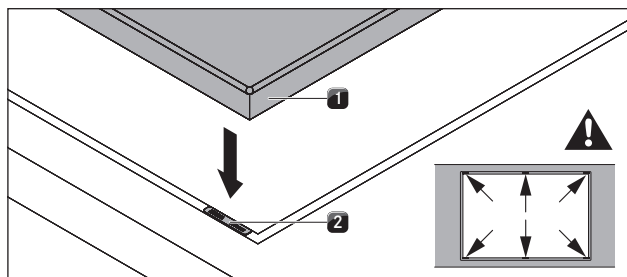

Fig. 6.37 Height adjustment plates

- [1] Cooktop
- [2] Height adjustment plate

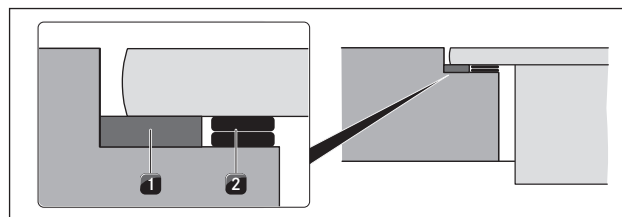

Fig. 6.38 Height adjustment plates

- [1] Sealing tape
- [2] Optional height adjustment plates

- The height adjustment plates are self-adhesive to prevent slipping during installation.
- ▶ If necessary, lay the height adjustment plates [2] underneath.
- ▶ Place the height adjustment plates next to the sealing tape [2].

6.7.8 Securing the cooktop

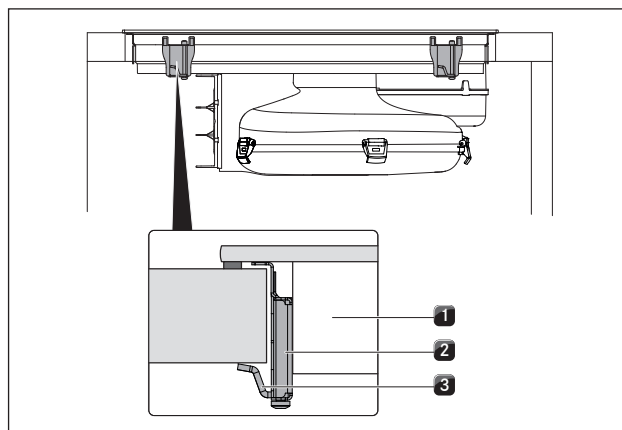

Fig. 6.39 Securing the cooktop

- [1] Cooktop
- [2] Installation clamp
- [3] Fixing bracket

- ▶ Secure the cooktop to the worktop [1] with the fixing bracket [3] on the installation clamp [2].

- Tightening torque: max. 2 Nm

6.7.9 Making a connection with the back wall (only in installation variant A)

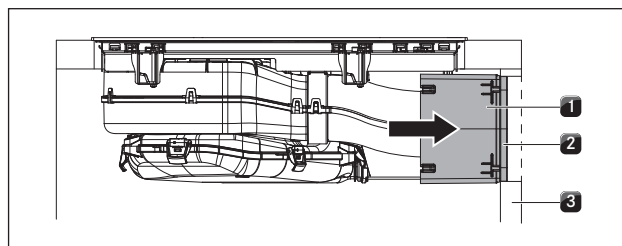

Fig. 6.40 Connection with the back wall

- [1] Telescopic pull-out
- [2] Adhesive tape
- [3] Back wall of unit

- ▶ Push the telescopic pull-out [1] until it is tight up against the back wall of the unit [3].
- With the telescopic pull-out the distance to the back wall of the unit can be flexibly bridged.
- ▶ Check that the telescopic pull-out [1] fits accurately, is flush with the cut-out on the back wall of the unit [3] and closes it off.
- ▶ Secure the telescopic pull-out [1] to the back wall of the unit [3] using the adhesive tape [2]

6.7.10 Inserting the activated charcoal filter

i Removing the filter – see “Cleaning” chapter, “Changing the filter”

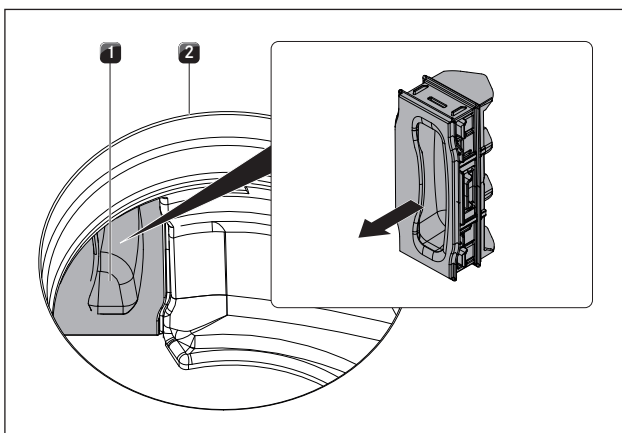

Fig. 6.41 Remove the filter replacement cover

- [1] Filter replacement cover
- [2] Inlet opening

- ▶ Inside the inlet opening [2] pull the filter replacement cover [1] out through the opening in the filter housing.

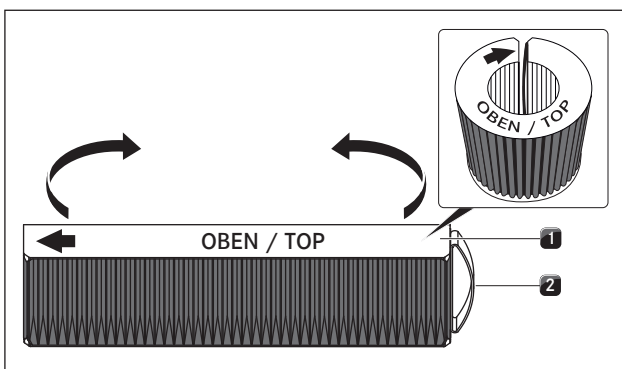

Fig. 6.42 Activated charcoal filter

- [1] Activated charcoal filter
- [2] Grip strap

- ▶ Remove the packaging from the activated charcoal filter [1].
- ▶ Position the activated charcoal filter correctly with the help of the printed symbols (arrow left, grip strap [2] right).
- ▶ Hold the activated charcoal filter at both ends.
- ▶ Bend the activated charcoal filter into a cylindrical shape so that both ends of the filter are opposite each other.

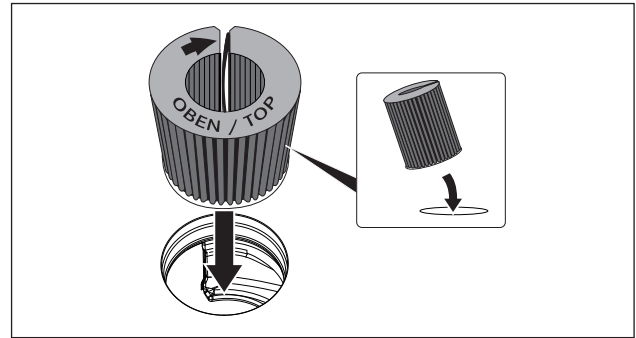

Fig. 6.43 Inserting the activated charcoal filter through the vent opening

- ▶ Tilt the activated charcoal filter towards you slightly and insert it through the inlet opening.
- ▶ Guide the left end of the filter into the opening in the filter housing.

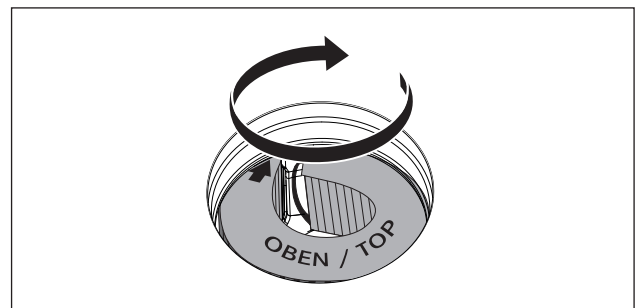

Fig. 6.44 Placing the activated charcoal filter in the end position

- ▶ Push the activated charcoal filter into the filter housing until it will go no further (to do this, you can place one finger between the slats and gradually push the filter into the housing).
- The end position of the activated charcoal filter is reached when the filter has been fully pushed inside the filter housing.

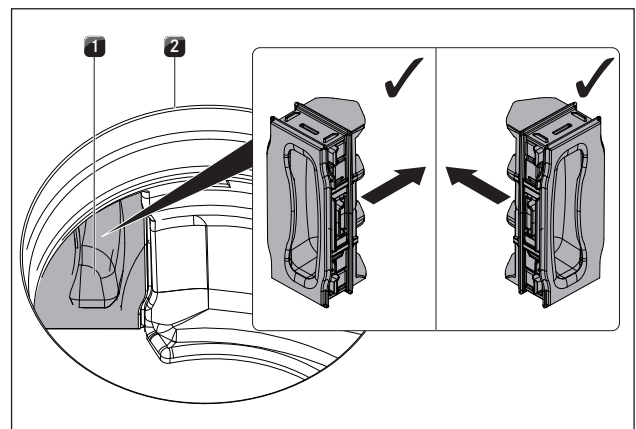

Fig. 6.45 Inserting the filter replacement cover

- [1] Filter replacement cover
- [2] Inlet opening

- ▶ Inside the inlet opening push the filter replacement cover until it comes to a stop in the filter housing opening.
- ▶ Check that the filter replacement cover is positioned correctly.

6.8 Establishing the power connection

- ▶ Observe all safety and warning information (see the “Safety” chapter).
- ▶ Observe all national and regional laws and regulations as well as the supplementary regulations of the local utility companies.

- i** The power connection may only be established by certified specialists. The specialist also assumes responsibility for the proper installation and commissioning.
- i** Connections via plug-in contacts (Schuko plugs) are not permitted.
- i** 1-phase connection The device complies with the requirements of IEC 61000-3-12.
- i** With the optional Home In accessory module PUHIM (12 V/35 mA), upgrade to an interface for external devices (e.g. window contact switch) is possible.

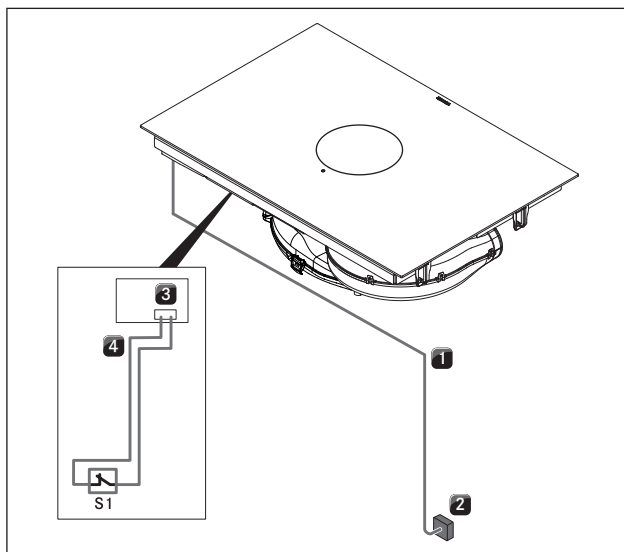

Fig. 6.46 Connection diagram with optional Home In module

- [1] Cooktop and cooktop extractor power supply cable
- [2] Power supply
- [3] Home In module PUHIM (not included in scope of delivery)
- [4] Home In connection cable
- [S1] External switch contact

- ▶ Switch off the main switch/automatic circuit breaker before connecting the cooktop.
- ▶ Secure the main switch/automatic circuit breaker against being switched back on without permission.
- ▶ Make sure the power to the appliance is disconnected.
- ▶ Connect the cooktop exclusively via a fixed connection to an H 05 VV-F power supply cable with corresponding minimum cross-section (see tab. Fuse protection and minimum cross-section).

Connection	Fuse protection	Minimum cross-section
Three-phase connection	3 x 16 A	2.5 mm ²
Two-phase connection	2 x 16 A	2.5 mm ²
One-phase connection	1 x 32 A	4 mm ²

Tab. 6.2 Fuse protection and minimum cross-section

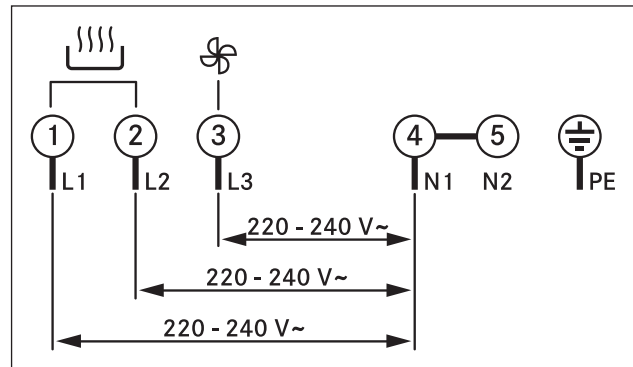

Fig. 6.47 Connection diagram - three-phase connection

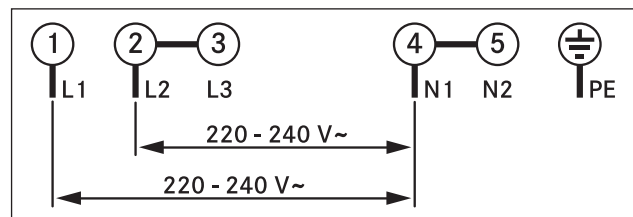

Fig. 6.48 Connection diagram - two-phase connection

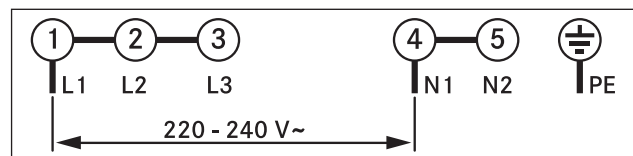

Fig. 6.49 Connection diagram - one-phase connection

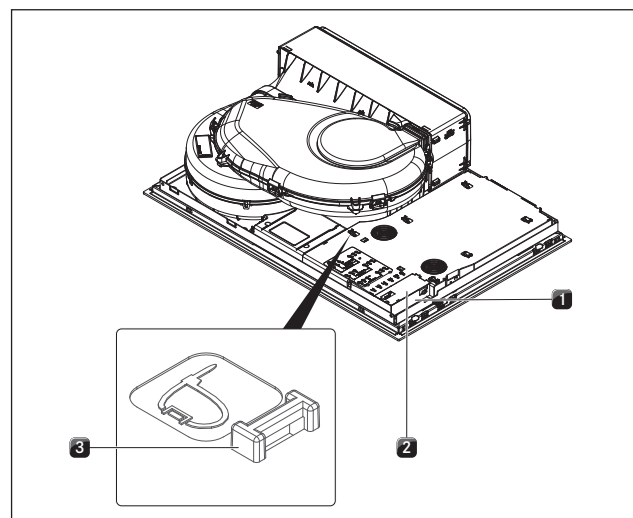

Fig. 6.50 Electrical connections of the cooktop

- [1] Power supply
- [2] Power supply cover
- [3] Mounting eyes

- ▶ Connect the power supply cable to the power supply [1] of the device in accordance with the relevant connection diagram (see Fig. Connection diagram or underside of appliance).
- ▶ For a one-phase or two-phase connection, connect the relevant contacts using the bridge provided (in scope of delivery).
- ▶ Secure the connection cable with the strain relief clamp (in scope of delivery).
- ▶ Close the power supply housing with the power supply cover [2] (in scope of delivery).
- ▶ Lay the connection cable along the mounting eyes [3] with the help of the cable ties (in scope of delivery).
- ▶ Ensure that the cable is not trapped or damaged and is not able to come into contact with any hot areas on the cooktop.
- ▶ Check that installation has been carried out correctly.

6.9 Initial operation

i During initial operation some basic settings (basic configuration) must be applied using the dealer and service menu.

6.9.1 Dealer and service menu

- i** The dealer and service menu can be called up up to 2 minutes after the appliance has been connected to the power supply.
- i** The system adopts and saves the settings made when you exit the corresponding menu item.
- i** Below you will find explanations on how to use the menu and a description of the most important menu items.

Dealer and service menu overview

Menu item/Description/Selection area	Factory setting
B Extraction system (exhaust air/ recirculation system)	Recirculation
C Power management	☐
D Demo mode	Off

Tab. 6.3 Menu overview

Calling up the dealer and service menu

- ▶ Connect the appliance to the power supply.

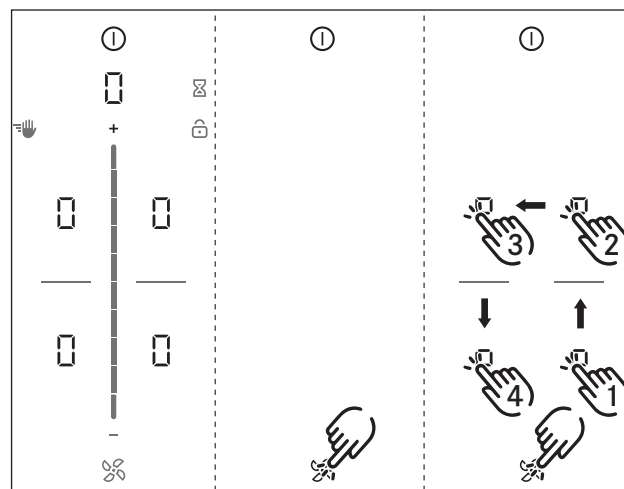

Fig. 6.51 Calling up the dealer and service menu

- The standard display appears and the fan symbol pulses for 2 minutes.
- ▶ Long press on the fan button .
- 4 input points are shown.
- ▶ Keep the fan button pressed and at the same time press the input points in the specified order.
- Menu item B is displayed.

Menu item B: configuration of the extraction system

The extraction system must be configured.

There are two operating modes to choose from:

- Operating mode 1: recirculation system (factory setting)
- Operating mode 2: exhaust air system

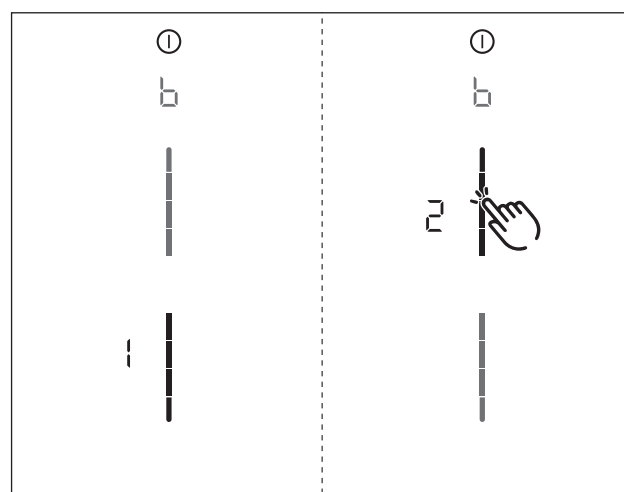

Fig. 6.52 Display Menu item B: configuring the extraction system

- ▶ Select the corresponding operating mode (tap the corresponding segment on the slider).
- ▶ Confirm and save the setting by moving to the next menu item (tap the multi-function display/indicator .

Menu item C: power management

The total appliance power can be reduced if the required electrical power cannot be provided at the installation site.

- i** The cooking zone power restrictions automatically implemented by the appliance are determined according to the total power set.

There are three operating modes to choose from:

Power management	Connection	Maximum power consumption	Fuse protection
C3	three-phase	7.6 kW	3 x 16 A
C3	two-phase	7.6 kW	2 x 16 A
C3	one-phase	7.6 kW	1 x 32 A
C2	one-phase	4.4 kW	1 x 20 A
C1	one-phase	3.6 kW	1 x 16 A

Tab. 6.4 Power management

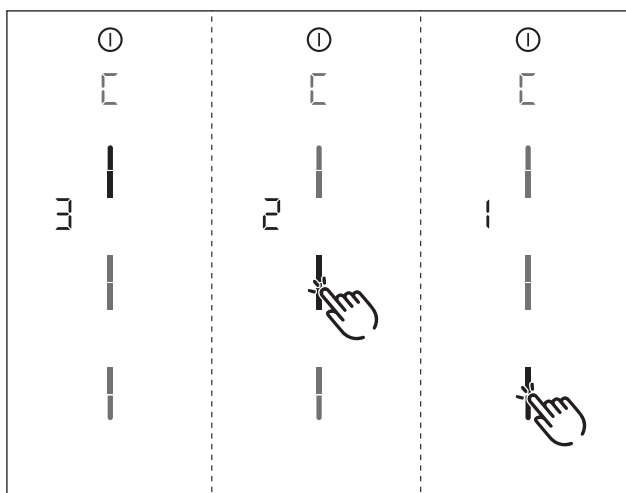

Fig. 6.53 Display menu item C: power management

- ▶ Select the corresponding operating mode (tap the corresponding segment on the slider).
- ▶ Confirm and save the setting by moving to the next menu item (tap the multi-function display/indicator □).

Menu item D: demo mode

The appliance can be set to demo mode, which includes all operating functions, but the heating function of the cooktops is deactivated.

- i** Pan size recognition is deactivated in demo mode.

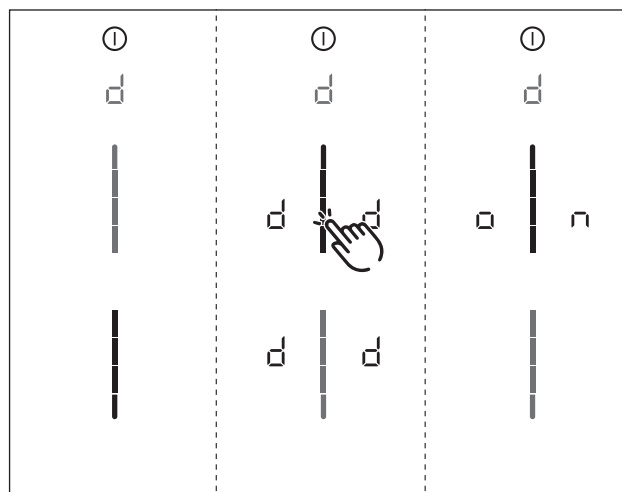

Fig. 6.54 Display Menu item D: demo mode

- ▶ Tap the top slider segment.
- The demo mode symbol **d** is displayed on all cooking zones for one second.
- □ is displayed.
- ▶ Confirm and save the setting by moving to the next menu item (tap the multi-function display/indicator □).

Closing the dealer and service menu

When you have been through all of the basic configuration menu items:

- ▶ long press on the multi-function display.
- The standard display appears.

6.9.2 Function test

- ▶ Carry out a thorough function test on all devices.
- ▶ In the event of error messages, see the Troubleshooting” chapter.

6.10 Sealing the device

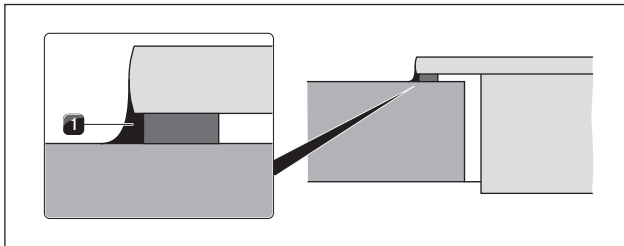

Fig. 6.55 Silicone sealant in surface mounting

[1] Black, heat-resistant silicone sealant

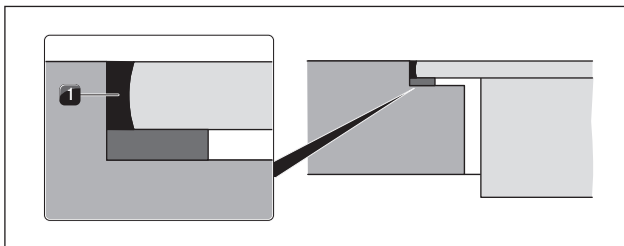

Fig. 6.56 Silicone sealant in flush installation

[1] Black, heat-resistant silicone sealant

- ▶ Once all of the installation work is complete, seal the device with black, heat-resistant silicone sealant [1].
- ▶ Make sure that no silicone sealant gets under the cooktop.

6.11 Handover to user

Once installation is complete:

- ▶ Explain the main functions to the user.
- ▶ Explain all safety-related aspects of operation and handling to the user.
- ▶ Provide the user with the accessories and operating and installation instructions to be kept in a safe place.

7 Operation

► Observe all safety and warning information during operation (see Safety chapter).

- i** Do not operate the integrated cooktop extractor with other cooktops.
- i** The cooktop should only be operated when the filter replacement cover, stainless steel grease filter and air inlet nozzle are installed (as well as the activated charcoal filter in the recirculation model).

7.1 General operating instructions

The cooktop extractor and cooktops are operated via a central operating panel. The operating panel is fitted with electronic sensor buttons and display panels. The sensor buttons respond to finger contact (see Appliance description chapter). You control the appliance by tapping the corresponding sensor button with your finger (touch control) or making a swiping movement with your finger (slider control).

7.2 Touch control

- i** The system recognises different touch commands. It differentiates between a brief touch (tap), a prolonged touch (long press) and vertical sliding movements with your finger (swiping).

Touch commands	applicable to	Time (contact)
Tap	Buttons + slider	0.3 s
Long press	Buttons + slider	1 – 8 s
Swipe	Slider	0.1 – 8 s

Tab. 7.1 Touch control

7.3 Operating the system

7.3.1 Switching on

- Long press on the power button 
- The switch-on animation is displayed in the slider.
- If start-up is successful, the standard display will appear in the operating panel.

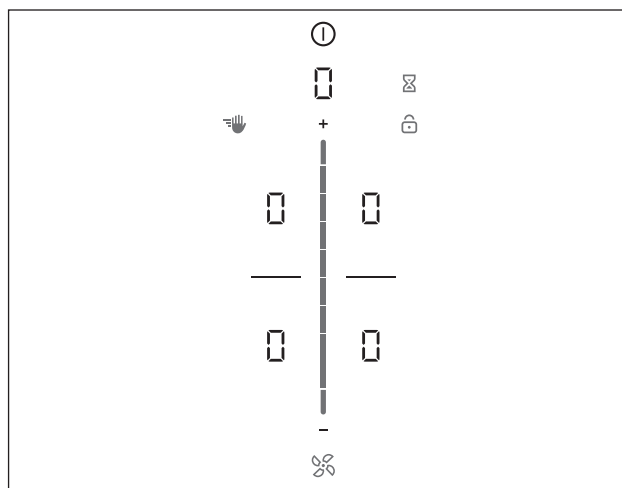



Fig. 7.1 Standard display after switching on

- i** If the childproofing feature is active, the lock button  will light up after system start-up. The standard display will only appear once it has been unlocked (see Childproofing feature).

7.3.2 Switching off

- Long press on the power button 
- The switching-off animation is displayed.

If the cooktop extractor has been on:

- The fan symbol will light up and the automatic after-run function will start (the automatic after-run animation is displayed).
- The display goes out when the after-run time has lapsed.

If the cooktop has been on:

- The residual heat indicator H is displayed for previously active and still hot cooking zones.
- The display goes out when no more residual heat is present.

7.3.3 Control lock

Activating the control lock

- Long press on the lock button 
- The operating panel display is dimmed.
- The lock button lights up.
- All functions are deactivated except for the power button and the lock button.

- i** If the system is switched off when the control lock is active, the control lock will no longer be active next time the system is switched on.

Deactivating the control lock

- Long press on the lock button 
- The standard display lights up and the operating panel is reactivated.
- The lock button is dimmed.

7.3.4 Childproofing feature

After switching on the appliance, the lock symbol  lights up in the operating panel display.

Permanently activating/deactivating the childproofing feature

See 7.6 User menu and 7.6.2 Menu item 2: Childproofing feature

Deactivating the childproofing feature for a cooking session

- ▶ Long press on the lock button .
- ▶ Swipe downwards
- The standard display lights up and the operating panel is reactivated.
- The lock button is dimmed.

7.3.5 Pause function

i With the pause function you can briefly pause the cooking session. The cooking session can be paused for a maximum of 10 minutes. If the pause function is not deactivated in this time, all cooking zones are switched off.

Activating the pause function

- ▶ Tap the pause button .
- The pause button lights up, all cooking sessions are paused and an acoustic signal is heard.
- The cooking zone indicators are dimmed.
- The pause timer is started (max. 10 min).



i During the pause, fan function is not interrupted. Egg-timer functions are maintained. Active cooking zone timers are stopped.

Deactivating the pause function

- ▶ Long press on the pause button .
- The pause button is dimmed.
- The cooking zone indicators light up.
- All cooking sessions are resumed at the power levels set prior to the pause.
- Active cooking zone timers are resumed.





7.3.6 Short-time timer (egg timer)

Activating the egg timer

- ▶ Tap the egg timer button .
- The time flashes in the 7-segment display above the sliders in minutes (.
- The cooking zones in the display are dimmed.

Setting the time

- ▶ Select the desired power level:

Command	Increase time	Decrease time
Swipe	 upwards	 downwards
Tap	 (exact to the minute)	 (exact to the minute)

Tab. 7.2 Setting the time

- The egg timer button  starts to flash.

Starting the egg timer

- ▶ Tap the flashing egg timer button .
- The set time starts to count down.
- The operating panel display changes to the standard display and the egg timer button is displayed.

Time lapsed

- 10 seconds before the set time lapses, the system flashes the remaining time.
- In the last 5 seconds of the countdown an acoustic signal can be heard every second.
- The time indicator  changes to the fan power level.

Deactivating the egg timer early

- ▶ Long press on the egg timer button .
- The egg timer function is ended.
- The operating panel display changes to the standard display.

i If the appliance is switched off, the egg timer will remain active.

7.3.7 Cleaning lock (wipe function)

Activating the cleaning lock

- ▶ Tap the cleaning button .
- The cleaning button lights up and all functions on the operating panel are locked for 10 seconds.
- The timer appears in the multi-function display and automatically counts down.



Deactivating the cleaning lock

- Once the timer has stopped you can use the functions again.
- or
- ▶ Long press on the cleaning button .
- The cleaning button is dimmed.

7.4 Operating the cooktop extractor

7.4.1 Setting the fan power level

The fan power levels can be adjusted in 3 different ways.

- ▶ By tapping a certain position on the slider .
- ▶ By swiping until you reach the required power level.
- ▶ By tapping  or .
- The fan symbol lights up and the set fan power level is shown in the multi-function display.

Increasing the power level

- ▶ Tap a higher position on the slider
- or
- ▶ swipe upwards to the required power level
- or
- ▶ tap  until the required power level is reached.

Reducing the power level

- ▶ Tap a lower position on the slider
- or
- ▶ swipe downwards to the required power level
- or
- ▶ tap  until the required power level is reached.

7.4.2 Fan power setting

Activating the fan power setting

- ▶ Tap on  when power level 9 is active.
- P appears in the display.

 After 5 minutes, the power setting is automatically switched back to power level 9.

Deactivating the fan power setting

The fan power setting is deactivated early if another power level is set (see Fan power levels).

7.4.3 Automatic extractor control

 The automatic extractor function automatically adjusts the extraction performance to the highest power level used on all connected cooking zones. If the cooking zone power level is changed, the extractor power is automatically adjusted.

 The extractor power is adjusted after a 20 second delay.



Activating the automatic extractor function:

- ▶ tap the fan button .
- The fan symbol lights up.
- An animation appears on the slider.
- P is displayed.

Deactivating the automatic extractor function:

- ▶ Swipe to a fan power level
- or
- ▶ tap the fan button .

7.4.4 Switching the fan off

- ▶ Swipe downwards to power level 0
- or
- ▶ tap  until power level 0 is reached.
- or
- ▶ long press on the fan button .
- or
- ▶ long press on the fan power level in the multi-function display.
- The automatic after-run function is started.

7.5 Operating the cooktop



7.5.1 Selecting a cooking zone

- ▶ Tap on a cooking zone .
- The cooking zone controls are activated for 2 seconds and you can apply settings to the chosen cooking zone.
- The additional cooking zone functions appear.
- ▶ Repeat this process to operate further cooking zones if necessary.

Changing to another cooking zone



- ▶ Tap another cooking zone within 2 seconds.
- The cooking zone lights up in the operating panel display.
- Operation of the second cooking zone is activated.
- The first cooking zone is dimmed in the operating panel display and the previous settings remain active or are adopted.

7.5.2 Setting cooking zone power levels

 The cooking zone power levels are shown in the corresponding cooking zone display as a 7-segment font ().

 Two seconds after the power level is changed, the operating panel display automatically returns to the standard display.

The cooking zone power levels can be adjusted in 3 different ways:

- ▶ By tapping a certain position on the slider.
- ▶ By swiping until you reach the required power level.
- ▶ By tapping  or .

Increasing the power level

- ▶ Tap the required cooking zone
- ▶ Tap a higher position on the slider.
- or
- ▶ swipe upwards to the required power level
- or
- ▶ tap **+** until the required power level is reached.

Reducing the power level

- ▶ Tap the required cooking zone.
- ▶ Tap a lower position on the slider
- or
- ▶ swipe downwards to the required power level
- or
- ▶ tap **-** until the required power level is reached.

7.5.3 Automatic heat up function

- i** The system automatically determines the heating time depending on the power level set.

Activating the automatic heat up function

- ▶ Tap the required cooking zone
- ▶ Adjusting the power level
- ▶ Long press on the slider **---** at a position lower than power level 9
- The automatic heat up function is activated.
- Whilst the automatic heat up function is active, the power level displayed will flash.
- When the heat up time has ended, the cooking zone will stay on the previously set power level (continuous cooking level).

Deactivating the automatic heat up function early

The automatic heat up function is deactivated early if a lower power level is set.

- i** If the power level of a cooking zone is increased when the automatic heat up function is active, the automatic heat up function remains active. The time is restarted for the new continuous cooking level. If the cooking zone power level is decreased while the automatic heat up function is active, the automatic heat up function is deactivated.

7.5.4 Cooktop power setting

Activating the power setting for a cooking zone

- ▶ Tap on **+** when power level 9 is active.
- **P** appears in the cooking zone display.

- i** After 5 minutes, the power setting is automatically switched back to power level 9.

Deactivating the power setting

The power setting is deactivated early if another power level is set (see Setting the power level).

7.5.5 Setting the warming level

Activating the warming level

- ▶ Tap the required cooking zone
- The additional cooking zone functions appear.
- ▶ Tap the warming button **W**
- The warming level is activated.
- **W** is displayed in the cooking zone display.
- The warming symbol **W** is shown next to the cooking zone.

Deactivating the warming function

- ▶ Tap the required cooking zone
 - ▶ Tap the warming button **W**
 - or
 - ▶ swipe right down to the bottom (power level 0)
 - The warming function is deactivated.
- Selecting a power level also deactivates the warming function.

7.5.6 Setting the variable warming level

- i** There are three warming levels to choose from (also see Appliance description chapter)

Activating the warming level

- ▶ Tap the required cooking zone
- ▶ Tap the warming button **W**
- The 1st warming level (**W**) is displayed.
- The warming symbol **W** is shown next to the cooking zone.

Increasing or reducing the warming level

- ▶ Swipe upwards or downwards until the required warming level is reached
- or
- ▶ Tap **+** or **-** until the required warming level is reached

Deactivating the warming function

- ▶ Tap the cooking zone on which the warming level is activated
- ▶ Swipe downwards
- or
- ▶ Long press on the warming button **W**
- The warming function is deactivated.
- The residual heat indicator **H** appears in the cooking zone display if necessary.

7.5.7 Bridging function

- i** When the bridging function is active, the two cooking zones on one side of the cooktop are linked and operated on the same power level.

- i** If both cooking zones are active before the bridging function is activated, the lower power level is adopted. If timers are active on the cooking zones, the lower timer value will be adopted for the bridging timer.

- i** If no suitable cookware is detected (pan size recognition) within 10 seconds with the bridging function active, the bridging function will be disabled and the cooking zones will be deactivated.

Activating the bridging function

- ▶ Tap both cooking zones at the same time.
- The bridging function is now active.
- The light that looks like a hyphen goes out and the additional functions are displayed.
- Zone functions apply to the linked cooking zones (double display).
- Both cooking zone indicators show the same power level.
- Active additional cooking zone functions are adopted.
- Changes to the power level now apply simultaneously to both cooking zones.

Setting power levels when the bridging function is active.

- ▶ Tap a cooking zone with an active bridging function.
- ▶ Set the power level (see Adjusting the power level)

Deactivating the bridging function

- ▶ Long press on one of the two cooking zones with an active bridging function
- or
- ▶ tap the cooking zones with an active bridging function simultaneously.
 - The bridging function is deactivated.
 - The hyphen symbol lights up
 - The power levels are set to 0
 - If a timer was active, it is deactivated.
 - If cookware is only detected on one of the two cooking zones, the bridging function is cancelled after ten seconds and the corresponding cooking zone is deactivated.



7.5.8 Automatic bridging function

- i** If the permanent pan size recognition is switched on (see Customer menu), the automatic bridging function is also activated.

7.5.9 Cooking zone timer





- i** To be able to activate the timer function, a cooking zone power level must first be set.
- i** The timer function can be used for each cooking zone. Several timers can be activated at the same time (multi-timer).

Activating cooking zone timers

- ▶ Tap on a cooking zone
- The additional cooking zone functions are displayed.
- If the chosen cooking zone is not yet active (= power level ) a power level can now be set.
- ▶ Tap the timer button 
- The time flashes in the multi-function display above the sliders in minutes (.

Setting the time



- ▶ Select the desired power level:

Command	Increase time	Decrease time
Swipe	 upwards	 downwards
Tap	 (exact to the minute)	 (exact to the minute)

Tab. 7.3 Setting the time

- The timer symbol  starts to flash.

Starting the timer

- ▶ Tap the flashing timer button 
- The set time starts to count down.
- The timer symbol  is shown next to the cooking zone.
- The operating panel display changes to the standard display after 2 seconds.
- 10 seconds before the set time lapses, the system flashes the remaining time.
- In the last 5 seconds of the countdown an acoustic signal can be heard every second.

Showing the remaining time



The cooking zone timer is active and the time counts down:

- ▶ Tap the cooking zone
- The remaining time is shown in the multi-function display.

Changing active timers

- ▶ Tap a cooking zone with an active timer
- The remaining time is displayed.
- ▶ Tap the timer button 
- The timer is stopped.
- The remaining time flashes in the display.
- The system changes to timer editing mode.
- ▶ Change the set time (see “Setting the time”).
- ▶ Confirm the new set time and start the timer (see “Starting the timer”).

Multi-timer

- ▶ Tap on a different cooking zone
- The additional cooking zone functions are displayed.
- If the chosen cooking zone is not yet active (= power level ) a power level can now be set.
- ▶ Tap the timer button 
- The time flashes in the 7-segment display above the sliders in minutes (.
- Now the time can be set and the timer started (see “Setting the time” and “Starting the timer” respectively).

Switching the timer off early

- ▶ Tap a cooking zone with an active timer
 - The remaining time is displayed.
 - ▶ Long press on the timer button 
- or
- ▶ long press on the cooking zone with an active timer
 - The timer is switched off.
 - The system switches to the standard display.
 - The cooking zone remains active on the set power level.

Time lapsed

- 10 seconds before the set time lapses, the system flashes the remaining time.
- In the last 5 seconds of the countdown an acoustic signal can be heard every second.
- The time display and the timer button flash.
- After the end of the set time the cooking zone is automatically deactivated (= power level).

7.5.10 Switching off the cooking zone

- ▶ Tap the required cooking zone.
 - ▶ Swipe right down to the bottom until appears in the cooking zone indicator
- or
- ▶ long press on the cooking zone
 - is displayed in the cooking zone display.
 - After 2 seconds, the standard display appears.
- or
- ▶ tap until appears in the cooking zone indicator.

7.6 User menu

Certain functions can be set in the user menu.

- i** Below you will find explanations on how to use the menu and a description of the most important menu items.
- i** The menu can only be called up if all cooking zones and the cooktop extractor are inactive. In addition, there must be no residual heat.

Calling up the user menu

- ▶ Switch on the device by pressing the power button .
- If start-up is successful, the standard display will appear in the operating panel.
- ▶ Long press on the multi-function display.
- The menu is called up and the first menu item is displayed.

Closing the user menu

- ▶ Long press on the multi-function display
- The menu is closed and the standard display appears.

Navigating the user menu

- ▶ Tap the multi-function display
- The system moves to the next menu item.
- The system automatically adopts and saves set values when you move to another menu item or close the menu.

User menu overview

Menu item/Description/Selection area	Factory setting
1 Volume of the acoustic signals (0-9)	4
2 Childproofing feature (On/Off)	Off
3 Show and reset filter status	
4 Duration of the automatic after-run function (10, 15, 20 min)	20 min
5 Touch zone reaction speed (1 slow, 2 medium, 3 fast)	2
6 LED test	
7 Permanent pan size recognition	Off
8 Software/hardware version	
9 Safety shut-down (1 long, 2 medium, 3 short)	2
A Super simple mode	Off
0 Reset to factory settings	

Tab. 7.4 User menu overview

7.6.1 Menu item 1: Volume of the acoustic signals

- i** In the event of an error message the acoustic signal is always heard at full volume and cannot be changed.
- i** The acoustic signal when switching on or off is always set to at least volume level 4.
- i** The current set volume is shown in the rear, left-hand cooking zone display when the menu item is called up.

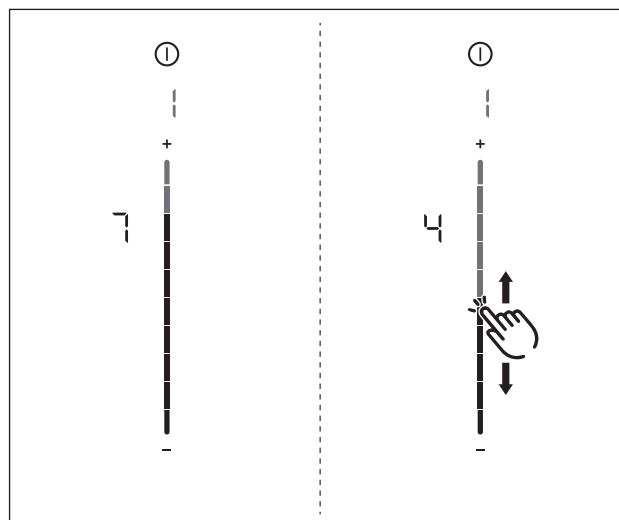

Fig. 7.2 Menu item 1: Volume of the acoustic signals

Setting the acoustic signal volume:

- ▶ Swipe upwards or downwards until the required volume is reached.
- ▶ Move to another menu item or close the menu.

7.6.2 Menu item 2: Childproofing feature

i With menu item 2 the childproofing feature can be permanently switched on or off. This setting is adopted for each new cooking session.

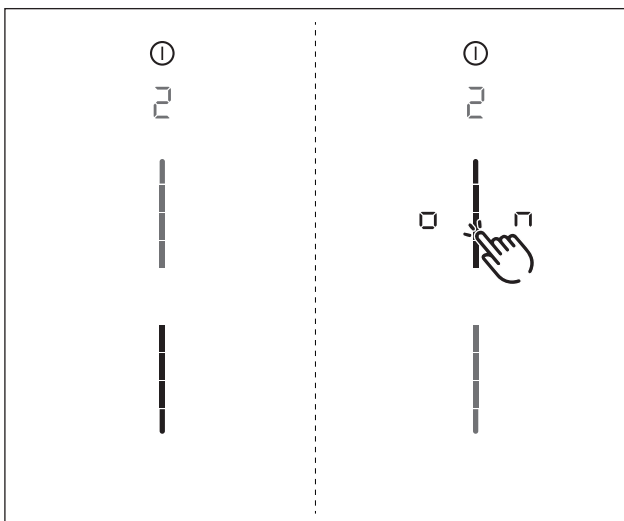

Fig. 7.3 Menu item 2: Childproofing feature

Permanently activating the childproofing feature

- ▶ Tap the top slider segment
- is displayed.
- ▶ Move to another menu item or close the menu.
- The childproofing feature is permanently activated.

Permanently deactivating the childproofing feature

- ▶ Tap the bottom slider segment
- ▶ Move to another menu item or close the menu.
- The childproofing feature is permanently deactivated.

7.6.3 Menu item 3: Showing and resetting the filter status (only in recirculation mode)

i If menu item 3 is called up, the filter status will be automatically shown.

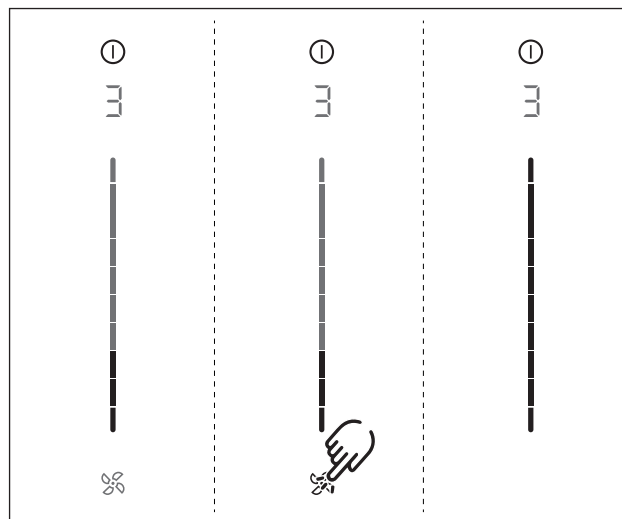

Fig. 7.4 Menu item 3: Show and reset filter status

Resetting the filter status:

- ▶ long press on the fan button .
- All slider elements are once again displayed at 100% brightness.
- ▶ Move to another menu item or close the menu.

7.6.4 Menu item 4: Duration of the automatic after-run function

i The duration of the automatic extractor function can be set using menu item 4.

There are three times to choose from:

- 20 minutes
- 15 minutes
- 10 minutes

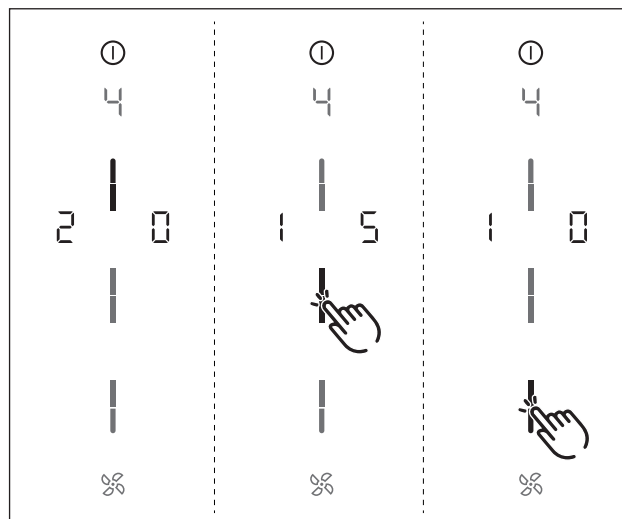

Fig. 7.5 Menu item 4: Duration of the automatic after-run function

- The current duration is displayed for 2 seconds.

Selecting the duration of the automatic after-run function:

- ▶ Tap the corresponding slider segment .
- ▶ Move to another menu item or close the menu.

7.6.5 Menu item 5: Touch zone reaction speed

i The reaction speed of the touch zones can be set using menu item 5.

- Reaction speed 1: slow
- Reaction speed 2: medium
- Reaction speed 3: fast

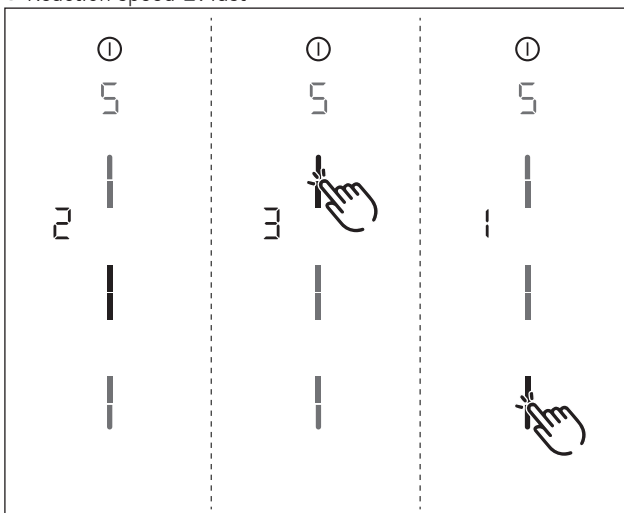



Fig. 7.6 Menu item 5: Reaction speed

- The current reaction speed is displayed.

Selecting the reaction speed:

- ▶ Tap the corresponding slider segment .
- ▶ Move to another menu item or close the menu.

7.6.6 Menu item 6: LED test

i With menu item 6 all LEDs in the individual touch zones can be tested to ensure that they are working.

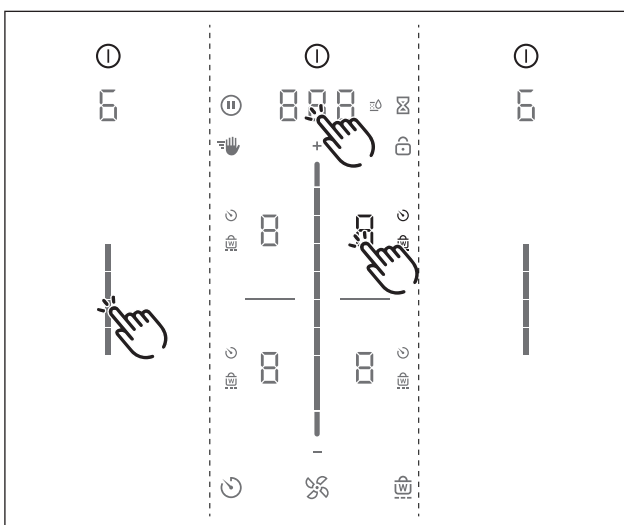



Fig. 7.7 Menu item 6: LED test

Starting the LED test

- ▶ Tap the slider zone .
- All indicators are displayed at 50 % brightness.
- ▶ Tap any indicator you wish.
- The selected indicator will be displayed at 100% brightness for one second.
- Any other indicators can be tested by touch as required.

Ending the LED test

- The LED test will be automatically ended when there has been no activity for 5 seconds.

or

- ▶ long press on the multi-function display.
- The LED test is ended.
- ▶ Move to another menu item or close the menu.

7.6.7 Menu item 7: Permanent pan size recognition

i With menu item 7 the permanent pan size recognition can be permanently switched on or off.

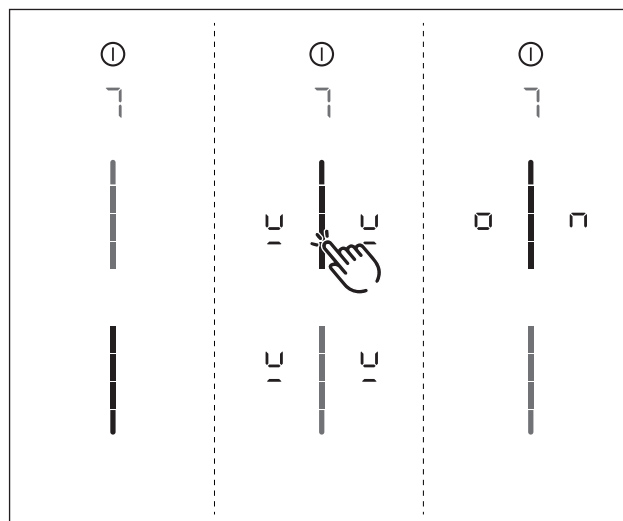





Fig. 7.8 Menu item 7: Permanent pan size recognition

Activating permanent pan size recognition

- ▶ Tap the top slider segment .
- The pan size recognition symbol  is displayed on all cooking zones for one second.
-  is displayed.
- ▶ Move to another menu item or close the menu.

Deactivating permanent pan size recognition

- ▶ Tap the bottom slider segment .
- ▶ Move to another menu item or close the menu.

7.6.8 Menu item 8: Show software/hardware version

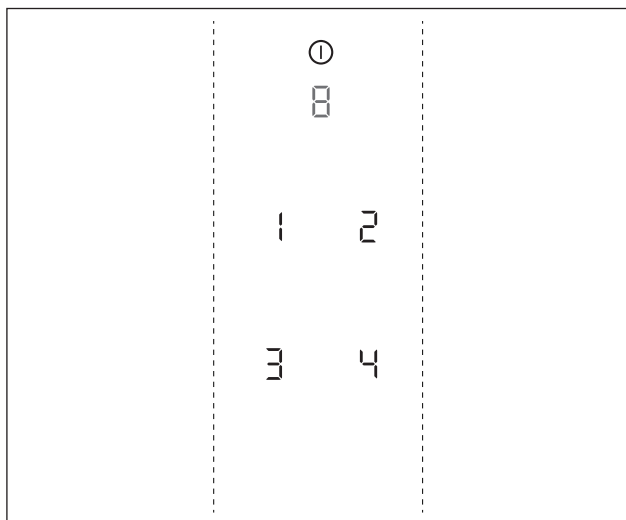

Fig. 7.9 Menu item 8: Software/hardware version

- The software/hardware version is shown via the four 7-segment cooking zone indicators.
- ▶ Move to another menu item or close the menu.

7.6.9 Menu item 9: Safety shut-down

i The time span (level) until automatic safety shut-down of the cooking zones can be selected using menu item 9.

- Level 1: long time span until automatic safety shut-down
- Level 2: medium time span until automatic safety shut-down
- Level 3: short time span until automatic safety shut-down (see Appliance description chapter, Safety shut-down)

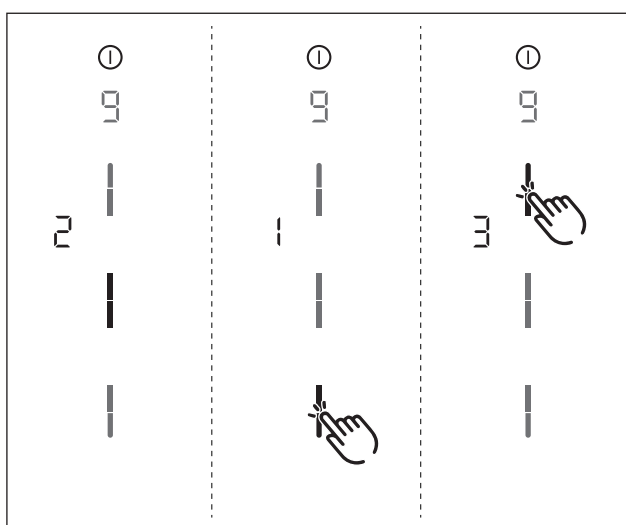



Fig. 7.10 Menu item 9: Safety shut-down

- The current level is displayed.

Selecting the level:

- ▶ Tap the corresponding slider segment .
- ▶ Move to another menu item or close the menu.

7.6.10 Menu item A: Super simple mode

i In super simple mode certain additional functions are deactivated and their indicators are faded out.

The following additional functions are deactivated in super simple mode:

- cooking zone timer
- short-time timer (egg timer)
- cleaning lock (wipe function)
- control lock
- heat retention function
- pause function

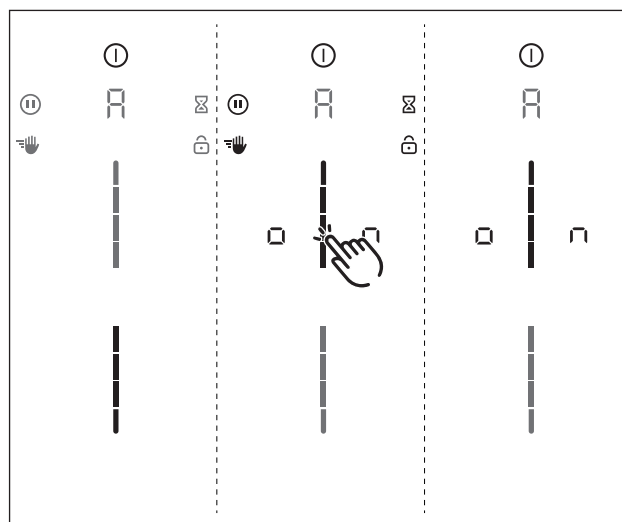



Fig. 7.11 Menu item A: Super simple mode

Activating super simple mode

- ▶ Tap the top slider segment .
- The additional function indicators, which were deactivated, flash and fade.
-  is displayed.
- ▶ Move to another menu item or close the menu.
- The additional functions are permanently deactivated and are not displayed.

7.6.11 Menu item 0: Reset to factory settings

i Menu item 0 enables all settings in the customer menu to be reset to the factory settings.

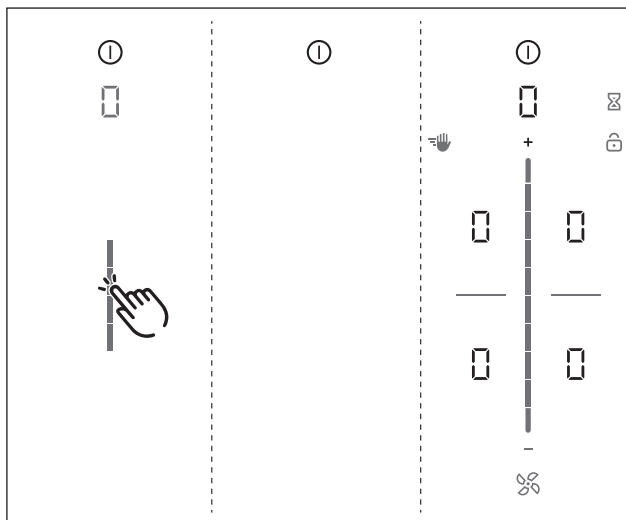



Fig. 7.12 Menu item 0: Factory settings

Resetting to factory settings

- ▶ Long press on the slider zone 
- The reset is started
- The device is restarted.
- The reset is complete when the standard display appears.

8 Cleaning and Maintenance

- ▶ Observe all safety and warning information (see the Safety chapter).
- ▶ Follow the enclosed manufacturer's information.
- ▶ When conducting scheduled cleaning and maintenance, ensure that the cooktop and cooktop extractor are fully switched off and cooled so as to prevent injury (see the Operation chapter).
- Regular cleaning and maintenance ensures long service life of the product and optimal function.
- ▶ Adhere to the following cleaning and maintenance cycles:

Component	Cleaning cycle
Operating panel	Immediately after every soiling
Cooktop	Clean with conventional glass ceramic detergents immediately after soiling and on a weekly basis
Cooktop extractor	Weekly
Air inlet nozzle and stainless steel filter	After cooking very greasy dishes; at least once a week, when the fan level indicator shows F clean by hand or in the dishwasher (at 65 °C max.); clean the stainless steel surfaces in the polishing direction only!
Air guiding housing	Every 6 months or when replacing the activated charcoal filter
Activated charcoal filter (with recirculation only)	Replace if odours have built up, extraction power is dwindling or the fan power level indicator shows F

Tab. 8.1 Cleaning cycles

8.1 Cleaning agents

- i** Due to the use of aggressive cleaning agents and abrasion caused by the pot bases the surface will become damaged and dark stains will occur.

To clean the cooktop, you need a special glass ceramic scraper and suitable cleaning agents.

- ▶ Never use steam cleaners, abrasive sponges, scouring pads or chemically aggressive cleaning agents (e.g. oven cleaner spray).
- ▶ Make sure that the cleaning agent does not contain any sand, soda, acids, lyes or chloride.

For air inlet nozzle and grease filter

- ▶ Do not use any aggressive cleaning agents or agents containing acid or lye.

8.2 Cooktop and extractor care

- ▶ Never use the cooktop as a work or storage surface.
- ▶ Do not push or pull cookware over the cooktop.
- ▶ Always lift pots and pans.
- ▶ Keep the cooktop and extractor clean.
- ▶ Remove any dirt immediately.
- ▶ Only use cookware suitable for glass ceramic cooktops (see Appliance description chapter).

8.3 Cleaning the cooktop

- i** When the cooktop extractor is in use the air inlet nozzle must be fitted so that no small or light objects such as fabric or paper cleaning cloths can be sucked in.

- ▶ Make sure that the cooktop is switched off (see the Operation chapter).
- ▶ Wait until all cooking zones are cold.
- ▶ Remove all coarse dirt and food residues from the cooktop using a glass ceramic scraper.
- ▶ Apply the cleaning agent to the cold cooktop.
- ▶ Spread the cleaning agent using kitchen roll or a clean cloth.
- ▶ Wipe the cooktop clean with a damp cloth.
- ▶ Dry the cooktop with a clean cloth.

If the cooktop is hot:

- ▶ Remove stubborn residues of plastic, aluminium foil, sugar or sweet dishes from the hot cooking zone immediately using a glass ceramic scraper to prevent burning.

Heavy soiling

- ▶ Remove heavy soiling and marks (limescale marks, mother-of-pearl-like shiny marks) using cleaning products while the cooktop is still warm.
- ▶ Wipe off food that boils over with a damp cloth.
- ▶ Remove any remaining dirt with the glass ceramic scraper.
- ▶ Always remove any seeds, crumbs or similar that fall onto the cooktop during cooking immediately to prevent the surface getting scratched.

Any changes in colour or glossy spots are not damage to the cooktops. They do not affect the functionality of the cooktop or the stability of the glass ceramic panel.

Changes in the colour of the cooktop are the result of residues which have not been removed and have burnt on.

Glossy spots are the result of wear by the pan base, especially if aluminium-based cookware or unsuitable cleaning agents are used. These are difficult to remove.

8.4 Cleaning the cooktop extractor

The air inlet nozzle and stainless steel grease filter absorb the greasy particles from cooking vapours.

- ▶ Make sure that the cooktop and cooktop extractor are switched off (see the Operation chapter).
- ▶ Wait until the fan indicator shows \square .
- ▶ Clean the cooktop extractor in accordance with the cleaning cycles.
- ▶ Clean the surfaces of the extraction system using a soft, damp cloth, detergent or a mild window cleaning agent.
- ▶ Soften dried on dirt using a damp cloth (do not scrape it off!).

8.4.1 Removing the components

Removing the X Pure air inlet nozzle

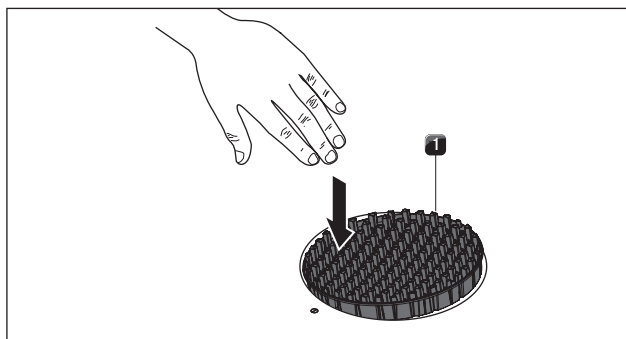

Fig. 8.1 Removing air inlet nozzle PUXA, PUXU

- [1] Air inlet nozzle

Prerequisite:

The fan level indicator shows \square .

- ▶ Tilt the air inlet nozzle [1] from its horizontal position.
- ▶ Remove the air inlet nozzle [1] with your other hand.

Removing the Pure air inlet nozzle

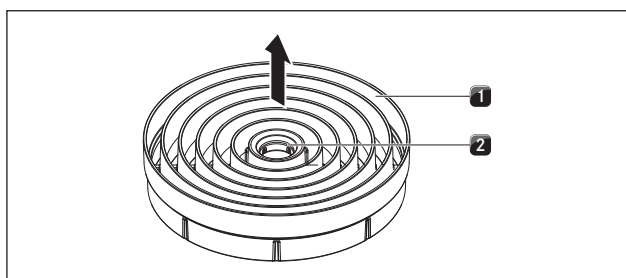

Fig. 8.2 Removing air inlet nozzle PURA, PURU

- [1] Air inlet nozzle
[2] Access opening

Prerequisite:

The fan level indicator shows \square .

- ▶ Reach into the access opening [2] of the air inlet nozzle [1] with your finger.
- ▶ Pull the air inlet nozzle [1] up and out.

Removing the stainless steel grease filter

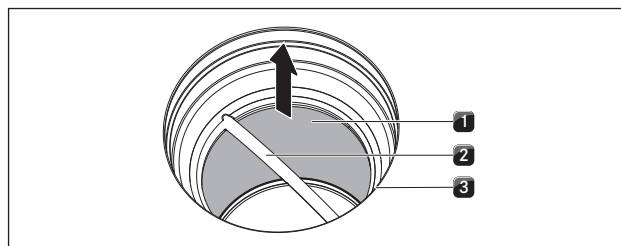

Fig. 8.3 Removing the stainless steel grease filter

- [1] Stainless steel grease filter
[2] Handle
[3] Inlet opening

- ▶ Take hold of the stainless steel grease filter by the handle [2].
- ▶ Pull the stainless steel grease filter [1] up and out of the suction opening [3].

8.4.2 Cleaning the air inlet nozzle and stainless steel grease filter

- i** If it is no longer possible to clean the stainless steel grease filter completely, it must be replaced – see Accessories chapter).

Manual cleaning

- ▶ Use a cleaner and degreaser in one.
- ▶ Rinse the air inlet nozzle and stainless steel grease filter with hot water.
- ▶ Use a soft brush to clean the air inlet nozzle and stainless steel grease filter.
- ▶ After cleaning, rinse the air inlet nozzle and stainless steel grease filter well.

Cleaning in the dishwasher

- ▶ Remove coarse food residues from the stainless steel filter
- ▶ Rinse the air inlet nozzle and stainless steel grease filter with a rinsing program at maximum 65 °C.

- i** To prevent water from dripping into the appliance, it is recommendable to shake the nozzle well upon removal from the dishwasher and, if necessary, to dry it with a tea towel.

8.4.3 Fitting the components

Inserting the stainless steel grease filter

- ▶ Take hold of the stainless steel grease filter by the handle [2].
- ▶ Insert the stainless steel grease filter [1] in the inlet opening [3]. A lock is not provided or necessary.

Inserting the air inlet nozzle

- ▶ Insert the air inlet nozzle in the inlet opening.
- ▶ Make sure it is positioned correctly.

8.4.4 Removing liquids from the device

Any liquids that flow into the device through the inlet opening are caught by the stainless steel grease filter (up to 150 ml) and in the air guiding housing. Do the following:

- ▶ Switch off the fan and deactivate the after-run function (see Operation chapter).
- ▶ Remove the air inlet nozzle and stainless steel grease filter (see Cleaning and Maintenance chapter).
- ▶ Empty the stainless steel grease filter.
- ▶ Check whether any liquid has gathered in the base of the air guiding housing.
- ▶ If necessary, wipe the liquid up from the housing base from above through the inlet opening using a sponge or cloth.
- ▶ Clean the air guiding housing (see Cleaning and Maintenance chapter, air guiding housing).
- ▶ To dry the odour filter and duct parts respectively, switch on the cooktop extractor at a minimum power level of 5.
- After 120 minutes the cooktop extractor will automatically switch to the automatic after-run function (see Device Description chapter).

8.5 Cleaning the air guiding housing

Grease particles and limescale residues from cooking vapours can settle on the surface of the air guiding housing. For this reason, regular cleaning is essential.

The air guiding housing can be found on the bottom of the cooktop inside the floor unit.

Opening the air guiding housing.

- ▶ Make sure that the cooktop and cooktop extractor are switched off (see the Operation chapter).
- ▶ Wait until the fan level indicator shows □.
- ▶ Remove the air inlet nozzle and stainless steel grease filter.
- ▶ Inside the inlet opening pull the filter replacement cover out of the filter housing opening (To remove the filter replacement cover see Fig. 8.5).

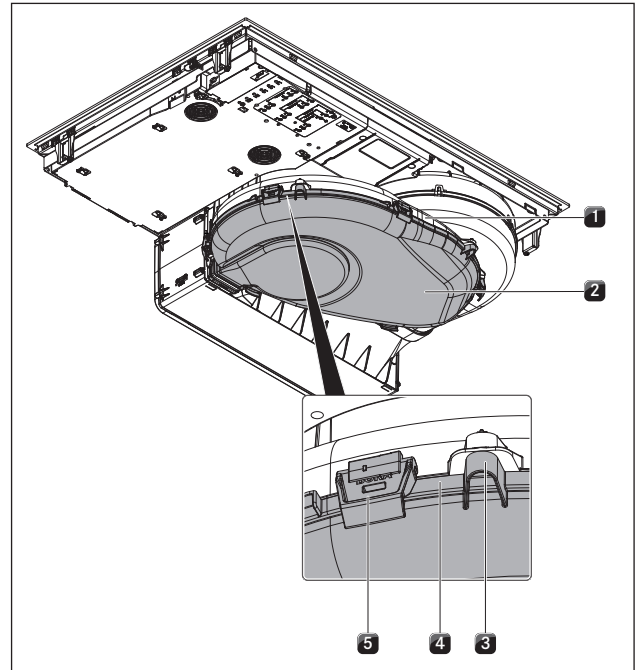

Fig. 8.4 Air guiding housing

- [1] Air guiding housing
- [2] Housing base
- [3] Spigot
- [4] Sealing groove
- [5] Lock

- ▶ Hold the housing base [2] with one hand.
- ▶ Release the 6 locks [5] around the edge of the base.
- ▶ Remove the housing base [2].

- ▶ Clean the air guiding housing [1] and the housing base [2] with a mild cleaning agent.

Closing the air guiding housing

- ▶ Position the housing base [2] under the air guiding housing [1] with the help of the 3 spigots [3].
- ▶ Push the housing base [2] upwards into the sealing groove [4].
- ▶ Close the 6 locks [5].
- ▶ Check that the housing base is positioned correctly.
- ▶ Inside the inlet opening push the filter replacement cover until it comes to a stop in the filter housing opening (To insert the filter replacement cover see Fig. 8.11).
- ▶ Check that the filter replacement cover is positioned correctly.
- ▶ Insert the stainless steel grease filter and the air inlet nozzle.

8.6 Replacing the activated charcoal filter

An activated charcoal filter will only be fitted with the stainless steel grease filter if the cooktop extractor is used in recirculation mode. The activated charcoal filter absorbs cooking odours that arise during cooking.

- i** The activated charcoal filter must be replaced when the fan indicator shows F (Filter service indicator). You can obtain the activated charcoal filter PUAKF from your specialist supplier or by contacting BORA via the website at www.bora.com/filter.

- ▶ Make sure that the cooktop and cooktop extractor are switched off (see the Operation chapter).
- ▶ Wait until the fan power level indicator shows □.

Removing the activated charcoal filter

- ▶ Remove the air inlet nozzle and stainless steel grease filter.

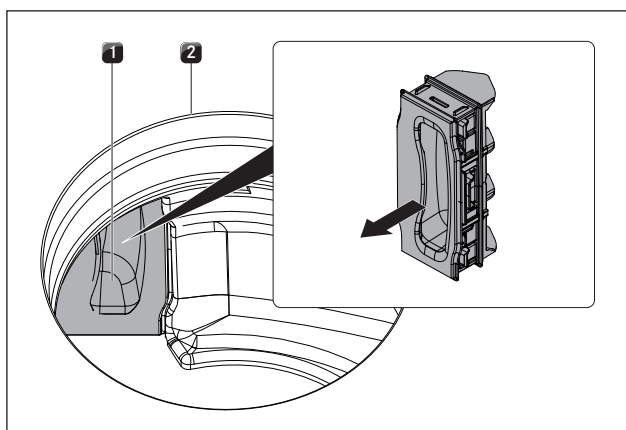

Fig. 8.5 Remove the filter replacement cover

- [1] Filter replacement cover
[2] Inlet opening

- ▶ Inside the inlet opening [2] pull the filter replacement cover [1] out through the opening in the filter housing.

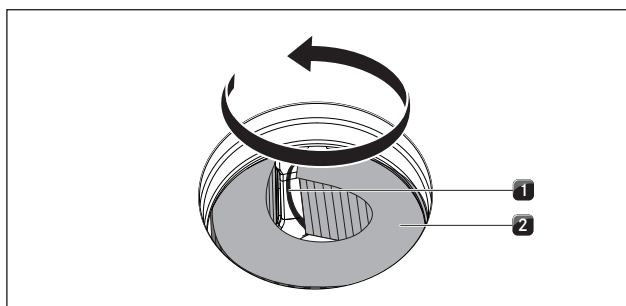

Fig. 8.6 Removing the activated charcoal filter from the filter housing

- [1] Grip strap
[2] Activated charcoal filter

- ▶ Take hold of the activated charcoal filter [2] by the grip strap [1] and pull it out as far as possible through the filter housing opening.

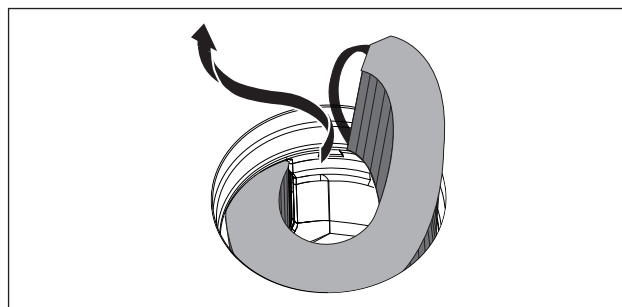

Fig. 8.7 Removing the activated charcoal filter through the inlet opening

- ▶ Take hold of the end of the activated charcoal filter and pull upwards and towards the left until it is completely out of the inlet opening.

Inserting the activated charcoal filter

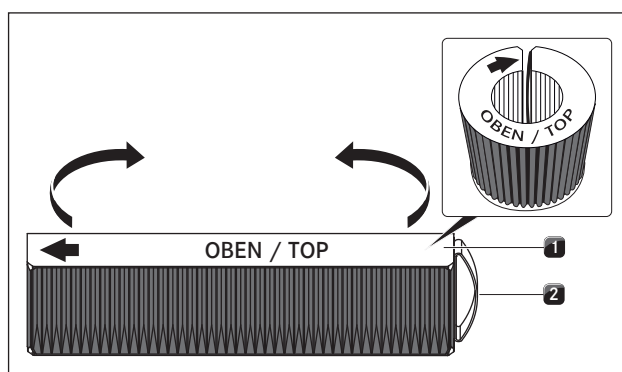

Fig. 8.8 Activated charcoal filter

- [1] Activated charcoal filter
[2] Grip strap

- ▶ Remove the packaging from the activated charcoal filter [1].
- ▶ Position the activated charcoal filter correctly with the help of the printed symbols (arrow left, grip strap [2] right).
- ▶ Hold the activated charcoal filter at both ends.
- ▶ Bend the activated charcoal filter into a cylindrical shape so that both ends of the filter are opposite each other.

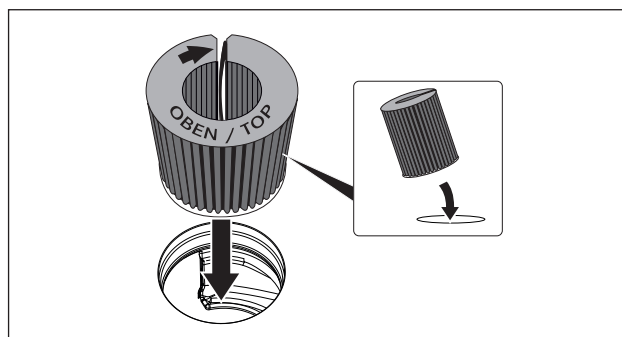

Fig. 8.9 Inserting the activated charcoal filter through the vent opening

- ▶ Tilt the activated charcoal filter towards you slightly and insert it through the inlet opening.
- ▶ Guide the left end of the filter into the opening in the filter housing.

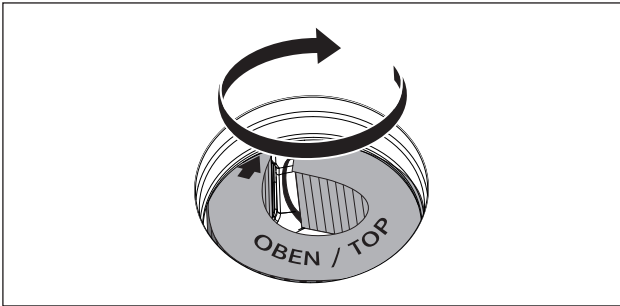

Fig. 8.10 Placing the activated charcoal filter in the end position

- ▶ Push the activated charcoal filter into the filter housing until it will go no further (To do this, you can place one finger between the slats and gradually push the filter into the housing).
- The end position of the activated charcoal filter is reached when the filter has been fully pushed inside the filter housing.

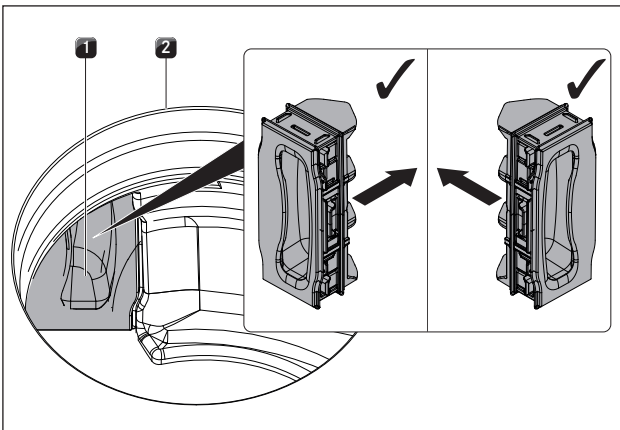

Fig. 8.11 Inserting the filter replacement cover

- [1] Filter replacement cover
- [2] Inlet opening

- ▶ Inside the inlet opening, push the filter replacement cover until it comes to a stop in the filter housing opening.
- ▶ Check that the filter replacement cover is positioned correctly.
- ▶ Insert the stainless steel grease filter and the air inlet nozzle.
- ▶ Reset the filter status indicator (see the Operation chapter, customer menu).

9 Troubleshooting

i You can often resolve faults and errors that can occur in day-to-day operation yourself. That way you save time and money as you don't need to call out customer services.

► Observe all safety and warning information (see the Safety chapter).

Operating situation	Cause	Remedy
The cooktop or the fan cannot be switched on	The fuse or automatic circuit breaker of the electrical wiring system in the apartment and/or house is defective	Replace the fuse. Switch the automatic circuit breaker back on
	The fuse/automatic circuit breaker trips several times	Contact the BORA Service team
	The power supply is disconnected	Have a specialist electrician inspect the power supply
Build-up of odours when new cooktop extractor is in operation	This is normal on brand-new appliances	Odours stop forming after a few operating hours
 is displayed in the cooking zone display	No or unsuitable cookware on the cooking zone	Use suitable cookware. Select the cookware size depending on the cooking zone (see the Appliance Description chapter)
The lock symbol is brighter than the other indicators	The childproofing feature is activated	Switch off the childproofing feature (see the Operation chapter).
A cooking zone or the entire cooktop switches off automatically	The maximum cooking zone operating time has been exceeded	Put the cooking zone back into operation (see the Operation chapter)
The power setting is automatically shut off prematurely	The overheating protection has tripped	(see the Appliance Description chapter)
The cooktop cooling fan continues to run when the cooktop has been switched off	The cooling fan runs until the cooktop has cooled	Wait until the cooling fan switches off automatically
The extraction performance of the cooktop extractor has decreased	The grease filter is extremely dirty	Clean or replace the grease filter
	The activated charcoal filter is extremely dirty (only with PUXU, PURU)	Replace the activated charcoal filter
	There is an object in the air guiding housing (e.g. cleaning cloth)	Remove the object
E is shown in the fan display	Home-In not authorised	Open the window
	The safety device is defective	Contact the BORA Service team
E2 is shown in the cooking zone	The overheating protection has tripped	(see the Appliance Description chapter)
E3 is displayed E is displayed in the fan display E3 is displayed in the rear cooking zones	Object on the operating panel	Remove the object from the operating panel
	The operating panel is dirty	Clean the operating panel
E4 is shown in the fan display	Use of a phase-separating window contact switch	Open the window
	The cooktop extractor is defective or a cable connection has become loose	Contact the BORA Service team
F is shown in the fan display (only with PUXU, PURU)	End of activated charcoal filter service life reached	Fit a new activated charcoal filter (see Cleaning and Maintenance chapter)

Tab. 9.1 Resolving a fault

Faults and errors not covered:

- Switch off the appliance.
- Contact the BORA Service Team (see Warranty, technical service and spare parts chapter) and enter the error number displayed and the appliance type.

10 Decommissioning, disassembly and disposal

- ▶ Observe all safety and warning information (see the Safety section).
- ▶ Follow the enclosed manufacturer's information.

10.1 Decommissioning

Decommissioning is understood as final shutdown and disassembly. Following decommissioning, the device can either be installed into other units, sold on privately or disposed of.

i Electricity and gas connections may only be disconnected by qualified specialists.

- ▶ To decommission, switch the device off (see Operation section)
- ▶ Disconnect the device from the power supply.

10.2 Disassembly

For removal, the device must be accessible for disassembly and disconnected from the power supply.

- ▶ Undo the appliance fixture.
- ▶ Remove the silicone joints.
- ▶ Remove the device from the worktop by lifting it upwards.
- ▶ Remove any other accessories.
- ▶ Dispose of the old device and any contaminated accessories as described under "Environmentally-friendly disposal".

10.3 Environmentally-friendly disposal

Disposal of transport packaging

i The packaging protects the device from damage in transport. The packaging materials have been selected from environmental and disposal perspectives and are therefore recyclable.

Returning the packaging to the materials cycle saves resources and reduces waste volumes. Your specialist supplier will take the packaging back.

- ▶ Give the packaging to your specialist supplier or
- ▶ Dispose of the packaging properly in line with local regulations.

Disposal of old appliance



Electrical devices marked with this label may not be disposed of in domestic waste at the end of their service life. They must be disposed of at a collection point for the recycling of old electrical or electronic devices. You can find information from your city or district council.

Many electrical and electronic devices still contain valuable materials. But they also contain damaging materials which were necessary for them to function properly and safely. These can damage human health or the environment if disposed of improperly or incorrectly handled.

- ▶ Never put your old appliance in domestic waste.
- ▶ Take the old appliance to a regional collection point for return and recycling electrical and electronic components and other materials.

11 Warranty, technical service, spare parts, accessories

- Observe all safety and warning information (see the Safety chapter).

11.1 BORA manufacturer's warranty

BORA provides its end customers with a 2-year manufacturer's warranty for its products. The end customer is entitled to this warranty in addition to the statutory claims for defects against the sellers of our products.

The manufacturer's warranty applies to all BORA products sold by authorised BORA dealers with the European Union, with the exception of products labelled by BORA as Universal products or accessories.

The manufacturer's warranty starts as soon as the BORA product is handed over to the end customer by an authorised BORA dealer and is valid for 2 years. By registering on www.bora.com/registration the end customer has the possibility of extending the manufacturer's warranty.

The manufacturer's warranty requires expert (in accordance with the valid BORA ventilation handbook and operating instructions at the time of installation) installation of the BORA products by an authorised BORA dealer. During use, the end customer is to adhere to the specifications and instructions in the operating manual.

In order to file a warranty claim, the end customer is to notify their dealer or BORA of the fault and must present the receipt. Alternatively, the end customer can provide proof of purchase by registering on www.bora.com.

BORA guarantees that all BORA products are free from material and product defects. The defect must exist prior to delivery of the product to the end customer. In the event that a warranty claim is filed, the warranty shall not commence anew.

BORA will correct defects in BORA products at its own discretion by repairing or replacing the product. All costs for the correction of defects under the manufacturer's warranty shall be assumed by BORA.

Expressly not covered by the BORA manufacturer's warranty are:

- BORA products that were not sold by authorised BORA dealers
- Damage caused by non-adherence to the operating instructions (including product care and cleaning) This represents improper use.
- Damage caused by normal use, e.g. traces of usage on the cooktop
- Damage caused by external influences (such as transport damage, ingress of condensation, damage caused by the elements such as a lightning strike)
- Damage caused by repairs or attempts to repair not made by BORA or persons authorised by BORA
- Damage to the glass ceramic
- Voltage fluctuations
- Secondary damage or claims for damages beyond the defect
- Damage to plastic parts

Legal claims, particularly statutory claims for defects or product liability are not limited by the warranty.

If a defect is not covered by the manufacturer's warranty, the end customer can employ the services of the BORA technical service, however, they must cover the costs themselves.

The laws of the Federal Republic of Germany apply to these warranty conditions.

You can contact us by:

- Telephone: +49 800 7890 0987 Monday to Thursday from 08:00-18:00 and Friday from 08:00-17:00
- Email: info@bora.com

11.1.1 Warranty extension

You can extend the guarantee by registering at www.bora.com/registration.

11.2 Service

BORA Service:

see reverse side of operating and assembly instructions



- In the case of faults you cannot fix yourself, contact your BORA specialist supplier or the BORA Service Team. The BORA Service Team will require the type designation and serial number of your device (FD number). Both values are indicated on the rate plate in the warranty insert and the underside of the device.

11.3 Spare parts

- Only use original spare parts for repairs.
- Repairs may only be carried out by the BORA Service Team.

- i** Spare parts can be obtained from your BORA dealer, the BORA online service website at www.bora.com/service or by calling the service number provided.

11.4 Accessories

Accessories	PUXA	PUXU	PURA	PURU
Activated charcoal filter PUAKE		✓		✓
Stainless steel grease filter PUEF	✓	✓	✓	✓
Air inlet nozzle PUXED	✓	✓		
Air inlet nozzle black PUED			✓	✓
Air inlet nozzle greige PUEDG			✓	✓
Air inlet nozzle red PUEDR			✓	✓
Air inlet nozzle jade green PUEDJ			✓	✓
Air inlet nozzle orange PUEDO			✓	✓
Air inlet nozzle blue PUEDB			✓	✓
Side frame USL515	✓	✓	✓	✓
Side frame All Black USL515AB	✓	✓	✓	✓
Cooktop frame BKR830	✓	✓		
Cooktop frame BKR760			✓	✓
Glass ceramic scraper UGS	✓	✓	✓	✓
Home In module PUHIM	✓		✓	
Window contact switch UFKS	✓		✓	
Air cleaning box PULB (for conversion to recirculation)	✓		✓	
Air purification box telescopic pull-out PULBTA		✓		✓

Fig. 11.1 Accessories X Pure, Pure

12 Notes

Operating and installation instructions:

Original

Translation

Manufacturer: BORA Vertriebs GmbH & Co KG

The distribution and duplication of this document, as well as the use and disclosure of its contents are prohibited unless expressly authorised.

These operating and installation instructions have been drawn up with the greatest of care. But it cannot be ruled out that subsequent technical modifications have not yet been incorporated or the relevant content has not yet been adapted. Please accept our apologies in this eventuality. An updated version can be requested from the BORA Service Team. Subject to printing errors and mistakes.

© BORA Vertriebs GmbH & Co KG

All rights reserved.

D
BORA Lüftungstechnik GmbH
Rosenheimer Str. 33
83064 Raubling
Germany
T +49 (0) 8035 / 9840-0
F +49 (0) 8035 / 9840-300
info@bora.com
www.bora.com

A
BORA Vertriebs GmbH & Co KG
Innstraße 1
6342 Niederndorf
Austria
T +43 (0) 5373 / 62250-0
F +43 (0) 5373 / 62250-90
mail@bora.com
www.bora.com

INT
BORA Holding GmbH
Innstraße 1
6342 Niederndorf
Austria
T +43 (0) 5373 / 62250-0
F +43 (0) 5373 / 62250-90
mail@bora.com
www.bora.com

AU NZ
BORA APAC Pty Ltd
100 Victoria Road
Drummoyne NSW 2047
Australien
T +61 2 9719 2350
F +61 2 8076 3514
info@boraapac.com.au
www.bora-australia.com.au

