

EN Operating and installation instructions PKG3

BORA Pro gas cooktop

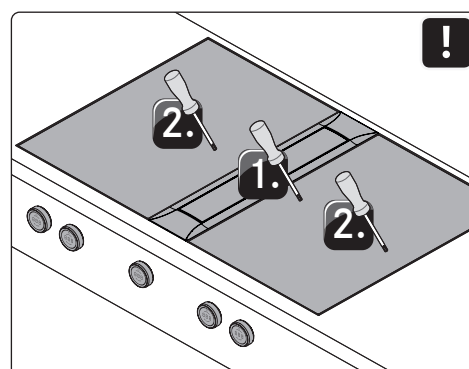
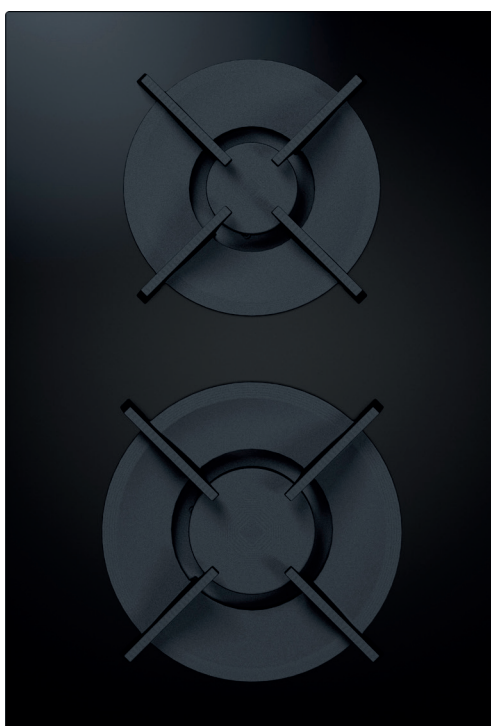

PKG3UMIMEN-101

Table of Contents

1	General information	4	5.5.2	Surface mounting.....	20
1.1	Liability.....	4	5.6	Installing the control knob in the floor unit front panel.	20
1.2	Validity of the operating and installation instructions.	4	5.6.1	Cooktop bore holes.....	20
1.3	Product conformity	4	5.6.2	Example bore holes.....	21
1.4	Data protection.....	4	5.6.3	Fitting the control knob.....	21
1.5	Presentation of information.....	4	5.7	Gas installation.....	22
2	Safety	5	5.7.1	Gas connection	22
2.1	Use as intended.....	5	5.7.2	Connecting the gas supply.....	22
2.2	People with limited abilities	5	5.7.3	Additional installation notes for Australia and New Zealand (AU/NZ).....	22
2.3	General safety instructions	5	5.7.4	Changing the gas type	23
2.4	Safety instructions for installation.....	6	- Changing the gas burner nozzle in the gas burner	23	
2.5	Safety instructions – operation.....	8	5.8	Installing the cooktops	25
2.6	Safety instructions – cleaning and maintenance	10	5.8.1	Installing the cooktop.....	25
2.7	Safety instructions – repairs, servicing and spare parts	10	- Inserting the cooktop (ports on the front).....	25	
2.8	Safety instructions – disassembly and disposal	10	- Levelling the cooktop (if necessary).....	25	
3	Technical data	11	- Securing the cooktop	26	
3.1	BORA Pro gas cooktop PKG3.....	11	5.8.2	Installation rotated by 180° (alternative installation variation)	26
3.2	BORA Professional 3.0 control knob dimensions.....	12	5.9	Establishing communication and power connection..	26
4	Appliance description	13	5.9.1	Connecting the control knobs.....	26
4.1	Control knob	13	- Connecting the control knobs to the cooktop	26	
- How it works.....	13	5.9.2	Establishing contact between the cooktop extractor and cooktops.....	27	
- Structure	13	5.9.3	Connecting the power supply	27	
- Operating elements	13	- Connecting the cooktop to the power supply.....	28		
- Control knob display.....	13	5.10	Basic configuration	28	
- Control knob assignment.....	13	5.10.1	Gas configuration	28	
4.2	Cooktop appliance description.....	14	5.11	Initial operation	28
- Display and symbols	14	5.11.1	Using the gas cooktop for the first time	28	
- Layout and size of the cooking zones	14	- Using the gas cooktop together with the cooktop extractor for the first time.....	28		
- Gas cooktop PKG3.....	14	- Faults during initial operation.....	29		
4.2.1	How gas cooktop PKG3 works.....	14	5.12	Function test.....	29
- Power levels.....	14	5.13	Sealing the appliances.....	29	
- Suitable cookware	14	5.14	Handover to user.....	29	
4.3	Safety devices.....	15	6	Configuration menu	30
- Safety shut-down.....	15	- Menu overview	30		
- Residual heat indicator	15	6.1	How to use the menu.....	30	
- Overheating protection	15	- Calling up the menu.....	30		
- Childproofing feature	15	- Selecting and confirming menu items.....	30		
5	Installation	16	- Making, confirming and saving settings	30	
5.1	General installation instructions	16	- Closing the menu.....	30	
5.2	Checking the scope of delivery.....	16	6.2	Initial operation	30
5.3	Tools and aids.....	16	6.2.1	Gas configuration menu items.....	30
5.4	Assembly instructions.....	17	- Menu item $\square E$: GPU configuration.....	30	
5.4.1	Safety clearances.....	17	- Menu item $\square F$: gas burner characteristic curves	31	
5.4.2	Minimum installation dimensions (standard set-up).....	17	- Menu item $\square h$: GPU reset	31	
5.4.3	Worktop and kitchen units.....	17	7	Functions and operation	32
5.4.4	Special installation instructions for gas cooktop PKG3.	17	7.1	Knob operation	32
- Positioning of the gas cooktop PKG3 with two cooktop extractors	18	- Operating the knob ring.....	32		
- Air supply for gas cooktop PKG3.....	18	- Operating the touch surface	32		
5.4.5	Recirculation when using the cooktop extractor as a recirculation system.....	18	7.2	Switching the system on and off	32
5.5	Cut-out dimensions	19	- Switching on	32	
5.5.1	Flush installation	19	- Switching off	32	

7.3	Operating the cooktops	33
7.3.1	General operating instructions for cooktops	33
7.3.2	Special operating instructions for gas cooktop PKG3	33
	- Correct use of the gas hob	33
	- Using the gas cooktop together with the cooktop extractor	34
7.3.3	Setting cooking zone power levels	34
	- Increasing the power level	34
	- Reducing the power level	34
7.3.4	Cooktop power setting	34
7.4	Function menu	34
	- Calling up the function menu	34
7.4.1	Variable heat retention function	35
	- Activating the heat retention function	35
	- Increasing or reducing the active heat retention level	35
	- Deactivating the heat retention function	35
7.4.2	Timer function/automatic cut-off	35
	- Activating cooking zone timers	35
	- Setting the time and starting the timer	36
	- Changing active timers	36
	- Switching the timer off early	36
	- Time lapsed	36
7.4.3	Automatic heat up function	36
	- Activating the automatic heat up function	36
	- Deactivating the automatic heat up function early	37
	- Time lapsed	37
8	Cleaning and maintenance	38
8.1	Cleaning agents	38
	- Cleaning products for glass ceramic cooktops	38
8.2	Cleaning the cooktops	38
8.2.1	Cleaning glass ceramic cooktops	38
8.2.2	Cleaning the pan supports	39
8.2.3	Cleaning the gas burner parts	39
8.3	Looking after your cooktops	40
8.4	Cleaning the control knobs	40
	- Cleaning the knob ring	40
	- Cleaning the touch surface and the knob housing	40
9	Troubleshooting	41
10	Decommissioning, disassembly and disposal	43
10.1	Decommissioning	43
10.2	Disassembly	43
10.3	Environmentally-friendly disposal	43
11	Warranty, technical service, spare parts, accessories	44
11.1	BORA manufacturer's warranty	44
11.2	Service	44
11.3	Spare parts	44
11.4	Accessories	44
12	Notes	45

1 General information

These instructions contain important information to protect you from injury and prevent damage to the appliance. Please read these instructions carefully before installing or using the appliance for the first time.

Other documents apply alongside these instructions. Please by all means adhere to all documents that form part of the scope of delivery.

Assembly, installation and commissioning must always occur in line with national laws, regulations and standards. The work must be performed by qualified specialists who are familiar with and comply with the supplementary regulations of the local utility companies.

All safety and warning information as well as the handling instructions in the accompanying documents must be observed.

1.1 Liability

BORA Holding GmbH, BORA Vertriebs GmbH & Co KG, BORA APAC Pty Ltd and BORA Lüftungstechnik GmbH – hereinafter referred to as BORA – does not assume any liability for damage arising from disregard for or non-adherence to the documents included in the scope of delivery!

Furthermore, BORA shall not be held liable for damage caused by improper installation or failure to observe the safety and warning instructions!

1.2 Validity of the operating and installation instructions

These instructions apply to several appliance versions. It is therefore possible that some of the features described do not apply to your appliance. The details of the figures contained herein may differ from some appliance versions and are to be understood as schematic diagrams.

1.3 Product conformity

Directives

The appliances meet the following EU/EC directives:

2014/30/EU EMC Directive
2014/35/EU Low Voltage Directive
2009/125/EC Ecodesign Directive
2011/65/EU RoHS Directive

Regulations

Gas appliances meet the following EU directives:
(EU) 2016/426 regulation on appliances burning gaseous fuels

1.4 Data protection

During operation your cooktop extractor saves pseudonymised data such as menu settings entered by you, operating hours of the individual technical units and the number of functions selected. Furthermore, your cooktop extractor documents errors in combination with the number of operating hours. Data can only be read out manually via your cooktop extractor. This decision is therefore your responsibility. These saved data then enable a rapid error search and troubleshooting in the event of servicing.

1.5 Presentation of information

We use standard formatting, numbering, symbols, safety instructions, terms and abbreviations so that you can work quickly and safely when using this manual.

The term “appliance” is used to refer to cooktops, cooktop extractors or cooktops with integrated cooktop extractor.

Instructions are indicated with an arrow.

► Always follow all instructions in the prescribed order.

Enumerations are indicated with a bullet point at the start of the line:

- Enumeration 1
- Enumeration 2

i Information notes point to special features that must be taken into account.

Safety and warning instructions



The safety and warning instructions in this manual are emphasised with symbols and signal words.

Safety and warning instructions are structured as follows:

⚠ WARNING SYMBOL AND SIGNAL WORD!		
Type and source of danger		
Results of non-compliance		
► Measures to minimise risk		

Please note:

- warning symbols draw attention to a high risk of injury.
- The signal word indicates the severity of that risk.

Warning symbol	Signal word	Risk
	Danger	Indicates an immediate, hazardous situation which causes death or serious injury if not respected.
	Warning	Indicates a potentially hazardous situation which can cause death or serious injury if not respected.
	Caution	Indicates a potentially hazardous situation which can cause minor injury or damage to property if not respected.

Tab. 1.1 Meaning of the warning symbols and signal words

2 Safety

The appliance complies with the stipulated safety requirements. The user is responsible for the safe use of the appliance, cleaning and maintenance. Improper use can lead to personal injury and damage to property.

2.1 Use as intended

The appliance is solely intended for preparing food in private households.

This appliance is not intended for:

- outdoor use
- heating rooms
- cooling, ventilating or dehumidifying rooms
- use in mobile installation sites such as motor vehicles, ships or aeroplanes
- use with an external timer or a separate remote control system (except for emergency shutdown)
- use at altitudes of over 2,000 m (metres above sea level)
- use with an extractor hood

Any other use or any use that goes beyond that which is described here is classed as unintended.

- i** BORA does not assume any liability for damages caused by improper use or incorrect operation.

All misuse is prohibited!

2.2 People with limited abilities

Children

The appliance can be used by children aged 8 and over if they are supervised or have been instructed how to use the appliance safely and understand the resultant risks. Children must not play with the appliance.

- ▶ Use the childproofing feature in order to prevent children from switching on the appliance or changing the settings when they are unattended.
- ▶ Supervise children in the vicinity of the appliance.
- ▶ Do not store any items that could be of interest to children in storage spaces above or behind the appliance. Otherwise, they will be tempted to climb onto the appliance.

- i** Any work involving cleaning and maintenance must not be carried out by children unless they are supervised at all times while doing so.

People with reduced physical, sensory or mental capacities

The appliance can be used by people with reduced physical, sensory or mental capacities or a lack of experience and/or knowledge if they are supervised or have been instructed how to use the appliance safely and understand the resultant risks.

Operation can be restricted using the childproofing feature.

⚠ DANGER!

Risk of burns from hot cookware and food

Handles projecting over the edge of the worktop are asking to be grabbed.

- ▶ Keep children away from hot cooking zones or ensure they are supervised at all times.
- ▶ Do not turn pot and pan handles so they stick out beyond the worktop.
- ▶ Make sure that hot pots and pans cannot be pulled down.
- ▶ If necessary, use suitable stove guards or covers.
- ▶ Only use stove guards and covers that are approved by the appliance manufacturer; otherwise, there is a risk of accidents.
- ▶ To choose a suitable stove guard, contact your specialist supplier or the BORA Service Team.

2.3 General safety instructions

⚠ DANGER!

Packaging components are a choking hazard

Packaging components (e.g. film, polystyrene) can be life-threatening for children.

- ▶ Store all packaging components out of reach of children.
- ▶ Dispose of the packaging properly and immediately.

⚠ DANGER!**Risk of electric shock or injury from damaged surfaces**

The underlying electronics can be exposed or damaged due to fissures, fractures or cracks in appliance surfaces (e.g. damaged glass), particularly in the vicinity of the operating unit. This can cause an electric shock. Furthermore, a damaged surface can cause injuries.

- ▶ Do not touch the damaged surface.
- ▶ If there are any cracks, fissures or fractures, switch the appliance off immediately.
- ▶ Safely disconnect the appliance from the mains using the LS switch, fuses, automatic circuit breakers or contactor.
- ▶ Contact BORA Service.

⚠ WARNING!**Risk of injury from damaged components**

Damaged components that cannot be removed without tools can cause injuries.

- ▶ Try not to repair or replace damaged components yourself.
- ▶ Contact BORA Service.

⚠ WARNING!**Risk of injury or damage due to incorrect components or unauthorised modifications**

Incorrect components can lead to personal injury or damage to the appliance. Modifications, additions or alterations to the appliance can lead to safety risks.

- ▶ Only use original components.
- ▶ Do not make any modifications, additions or alterations to the appliance.

CAUTION!**Appliance components can cause injury if dropped**

Appliance components (e.g. pan supports, operating controls, covers, grease filters, etc.) can cause injury if dropped.

- ▶ Place any appliance components that have been removed in a safe place near the appliances.
- ▶ Ensure that no components removed from the appliances can fall on the floor.

CAUTION!**Risk of injury from heavy lifting**

If not handled correctly, carrying and installing appliances can cause injury to the limbs or torso.

- ▶ If necessary, carry and install the appliance with another person.
- ▶ Use appropriate aids to prevent damage or injury.

CAUTION!**Damage from improper use**

The appliance surfaces must not be used as work or storage surfaces. This can damage the appliances (particularly in the case of hard and sharp objects). Never use the appliances as work or storage surfaces.

- ▶ Keep hard or sharp objects away from the appliance surfaces.

Faults and errors

- ▶ In the case of faults and errors, follow the instructions in the “Troubleshooting” chapter.
- ▶ In the event of any faults or errors that are not mentioned, switch the appliance off and contact BORA Service.

Pets

- ▶ Keep pets away from the appliance.

2.4 Safety instructions for installation

i Assembly, installation and commissioning of the appliance must always occur in line with national laws, regulations and standards. The work must be performed by qualified specialists who are familiar with and comply with the supplementary regulations of the local utility companies.

i During installation maintain the minimum clearance stated in the “Installation” (“Safety clearances”) chapter.

i Work on electrical components must only be conducted by trained electrical personnel.

The electrical safety of the appliance is only guaranteed if it is connected to a protective conductor system that has been installed in line with regulations. Ensure that this basic safety precaution is met.

The appliance must be suitable for the regional voltage and frequency.

- ▶ Check the information on the identification plate and in the event of deviations, do not connect the appliance.
- ▶ Conduct all work extremely attentively and conscientiously.
- ▶ Do not connect the appliance to the mains until the duct system has been installed or the recirculation filter has been fitted.
- ▶ Only use the connection cables supplied. Where necessary these are included in the scope of delivery.
- ▶ Do not use the appliance until installation is complete. This is the only way to ensure safe operation.

⚠ DANGER!

Risk of electric shock from damaged appliance

A damaged appliance can cause an electric shock.

- ▶ Check the appliance for visible damage prior to installation.
- ▶ Do not install or connect any damaged appliances.
- ▶ Do not operate any damaged appliances.

CAUTION!

Risk of burning from control knobs that are not positioned optimally.

If the control knobs are not installed in a suitable place, during operation there is a risk of sustaining burns from the cooktop surface.

- ▶ Only install the control knobs in a suitable place, which is practical and safe.

2.4.1 Safety instructions for cooktop installation

⚠ DANGER!

Risk of electric shock from incorrect mains connection

Connecting the appliance to the mains incorrectly poses a risk of electric shock.

- ▶ Make sure that the appliance has a fixed connection to the mains voltage.
- ▶ Make sure that the appliance is connected to a properly installed protective conductor system.
- ▶ Make sure that technical equipment is provided to enable all of the appliance's poles to be disconnected from the mains with a contact opening width of at least 3 mm (LS switch and automatic circuit breakers, fuses, contactor).

⚠ DANGER!

Risk of electric shock from damaged power supply cable

If the power supply cable is damaged (e.g. during installation or by coming into contact with hot cooking surfaces), this can cause an (lethal) electric shock.

- ▶ Make sure that the power supply cable does not become trapped or damaged.
- ▶ Make sure that the power supply cable does not come into contact with hot cooking surfaces.

Special safety instructions for the installation of gas cooktops

i Gas installation, appliance installation and replacing the gas nozzles, as well as changing the gas type and pressure, may only be carried out by reliable trained specialists, who are familiar with and comply with the standard national regulations and supplementary regulations of the local utility companies.

- ▶ Observe the special instructions on changing the gas type and pressure and the specifications for changing the gas nozzles in the nozzle table (see Operating instructions).

BORA gas cooktops must only be used with BORA cooktop extractors.

⚠ DANGER!

Risk of explosion and asphyxiation from gas

Leaking gas can lead to an explosion and result in severe injuries and property damage, or asphyxiation.

- ▶ Keep sources of ignition (naked flames, electric fires) away and do not operate any light switches, or switches on electrical appliances.
- ▶ Do not remove plugs from sockets (risk of sparking).
- ▶ Close the gas supply immediately and turn off the mains supply.
- ▶ Ensure there is a good supply of fresh air (open doors and windows).
- ▶ Plug any leaks immediately.

⚠ WARNING!**Risk of burns from wrongly placed control knobs**

If control knobs are not fitted as in sec5.6.6, they can become hot. Touching the hot control knobs can cause burns.

- ▶ Control knobs must be fitted at least 10 cm from the edge of the cooktop.
- ▶ If it is not possible to maintain a distance of at least 10 cm, measures must be put in place to protect the control knobs from the heat.

2.5 Safety instructions – operation

- ▶ Make sure that the base of the cookware as well as the appliance surfaces are clean and dry.
- ▶ Always lift (do not drag) cookware to prevent scratching and abrasion on the appliance surface.
- ▶ Do not use the appliance as a storage surface.
- ▶ Switch off the appliance after use.

⚠ WARNING!**Risk of burning from hot appliances**

Certain appliances and their exposed parts become hot during use. They should be left to cool down completely after switching off. Touching hot surfaces can cause serious burns.

- ▶ Do not touch hot appliances.
- ▶ Pay attention to the residual heat indicator.

⚠ WARNING!**Risk of burns due to power cut**

During or after a power cut a cooktop that was previously in operation may still be hot.

- ▶ Do not touch the appliance while it is still hot.
- ▶ Keep children away from the hot appliance.

⚠ DANGER!**Risk of fire from overheated oil or fat**

Oil or fat in the pot can quickly heat up and ignite.

- ▶ Never leave the appliance unattended when cooking with oil or fat
- ▶ Never extinguish oil and fat fires with water.
- ▶ Switch off the appliance.
- ▶ Extinguish the fire using a pan lid or a fire blanket, for example.

⚠ WARNING!**Risk of burning and fire from hot objects**

The appliance and its exposed parts are hot during operation and the cooling phase. Objects in contact with hot appliance components heat up very quickly and can cause severe burns (this particularly applies to metal objects such as knives, forks, spoons, lids or appliance components) or catch fire.

- ▶ Do not place any items on the appliance.
- ▶ Please use suitable accessories (pot holders, oven gloves).

2.5.1 Safety instructions – cooktop operation**⚠ DANGER!****Danger of fire caused by leaving the cooktop unattended**

Oil or fat in the pot can quickly heat up and ignite.

- ▶ Never leave oil or fat to heat up unattended.
- ▶ Never extinguish oil and fat fires with water.
- ▶ Switch off the cooktop.
- ▶ Extinguish the fire using a pan lid or a fire blanket, for example.

⚠ DANGER!**Danger of explosion caused by flammable liquids**

Flammable liquids in the vicinity of a cooktop can explode and cause serious injury.

- ▶ Do not spray aerosols near the appliance when it is in use.
- ▶ Do not place any flammable liquids in the vicinity of a cooktop.

⚠ WARNING!**Risk of burns from hot liquids boiling over**

Unattended pans can boil over allowing hot liquids to escape.

- ▶ Keep an eye on pans when cooking.
- ▶ Try not to let them boil over.

⚠ WARNING!**Risk of burns from hot steam**

Liquid between the cooking zone and the pan base can evaporate and cause burns.

- ▶ Make sure that the cooking zone and the pan base are always dry.

CAUTION!**Damage caused by sugary and salty foods**

Sugary and salty foods and juices can damage the hot cooking zone.

- ▶ Make sure sugary and salty foods or juices do not get onto the cooking zone while it is hot.
- ▶ Remove sugary and salty foods and juices from the hot cooking zone immediately.

Special safety instructions for the operation of gas cooktops

- i** The gas type and pressure must only be changed by reliable trained specialists who are familiar with and comply with the standard national regulations and supplementary regulations of the local utility companies.
- ▶ Do not use or store any flammable materials near the appliance.
- ▶ Do not use the appliance to heat the room.
- ▶ Before connecting the appliance, check that the appliance settings comply with local connection requirements (gas type and pressure).

⚠ DANGER!**Risk of carbon monoxide poisoning**

Extractor hoods and other cooking vapour extractors can impair the safe operation of appliances that use gas or other fuels due to the return flow of combustion gases. These gases can lead to carbon monoxide poisoning.

- ▶ Ensure that exhaust gases are properly removed.
- ▶ Ensure sufficient ventilation is provided during operation.
- ▶ Always have a qualified specialist check the safe operation of the gas appliance during commissioning.

⚠ DANGER!**Risk of explosion and asphyxiation from gas**

Leaking gas can lead to an explosion and severe injuries, or asphyxiation.

- ▶ If you smell gas while using the appliance, switch it off immediately.
- ▶ Keep sources of ignition (naked flames, electric fires) away and do not operate any light switches, or switches on electrical appliances.
- ▶ Do not remove plugs from sockets (risk of sparking).
- ▶ Close the gas supply immediately and turn off the mains supply.
- ▶ Ensure there is a good supply of fresh air (open doors and windows).
- ▶ Inform customer services or your gas installer immediately.

⚠ DANGER!**Fire risk from naked flame**

A naked flame can cause adjacent objects to catch fire.

- ▶ Turn the gas flame down to the lowest level if you remove pots or pans briefly from the hob.
- ▶ Never leave a naked flame unattended.
- ▶ Extinguish any fire using a lid or a fire blanket, for example.
- ▶ Close the gas supply and turn off the mains supply.

⚠ WARNING!**Risk of burns from hot cooktop extractor when using gas cooktops**

The cooktop extractor and its exposed parts (in particular the cover flap, stainless steel grease filter and grease filter tray) become hot when an adjacent gas cooktop is in use. The cooktop extractor must be left to cool down after the gas cooktop has been switched off. Touching hot surfaces can cause serious burns.

- ▶ Never touch the cooktop extractor when it is hot.
- ▶ Keep children away from the cooktop extractor when it is hot or ensure they are supervised at all times.

2.6 Safety instructions – cleaning and maintenance

The appliance must be cleaned at regular intervals. Dirt can lead to damage, restriction of functions, or bothersome odours. In the worst case scenario, this can become a hazard.

- ▶ Remove dirt immediately.
- ▶ When cleaning, only use non-abrasive detergents to prevent scratching and abrasion on the surface.
- ▶ When cleaning, ensure that no water penetrates the appliance. Use only a slightly damp cloth. Never spray the device with water. Water penetration can cause damage!
- ▶ Do not use a steam cleaner for cleaning. Steam can cause a short circuit on live parts and thus lead to property damage.
- ▶ Please follow all instructions in the “Cleaning and Maintenance” chapter.

Special safety instructions for cooktop cleaning and maintenance

- ▶ Whenever possible, clean the cooktops after every use.
- ▶ Only clean the cooktops when they have cooled down.

2.7 Safety instructions – repairs, servicing and spare parts

- i** The appliance must only be repaired and serviced by trained specialists who are familiar with and comply with the standard national regulations and supplementary regulations of the local utility companies.
- i** Work on electrical components must only be conducted by trained electrical personnel.
 - ▶ Before any repair work, safely disconnect the appliance from the mains supply.

⚠ WARNING!

Risk of injury or damage from improper repairs

Incorrect components can lead to personal injury or damage to the appliance. Modifications, additions or alterations to the appliance can lead to safety risks.

- ▶ Only use original spare parts for repairs.
- ▶ Do not make any modifications, additions or alterations to the appliance.

- i** A damaged power supply cable must be replaced by a suitable power supply cable. This may only be done by an authorised member of the After Sales Service team.

2.8 Safety instructions – disassembly and disposal

- i** The appliance must only be disassembled by trained specialists who are familiar with and comply with the standard national regulations and supplementary regulations of the local utility companies.
- i** Work on electrical components must only be conducted by trained electrical personnel.
 - ▶ Before disassembly, safely disconnect the appliance from the mains supply.

⚠ DANGER!

Risk of electric shock from incorrect disconnection

Incorrectly disconnecting the appliance from the mains results in a risk of electric shock.

- ▶ Safely disconnect the appliance from the mains using LS switches, fuses, automatic circuit breakers or contactors.
- ▶ Use an authorised measuring device to ensure that there is no power to the appliance.
- ▶ Do not touch exposed contacts on the electronic unit as they may contain residual charge.

Special safety instruction for the disassembly of gas cooktops

- i** The gas connection must only be worked on by reliable trained specialists who are familiar with and comply with the standard national regulations and supplementary regulations of the local utility companies.

3 Technical data

3.1 BORA Pro gas cooktop PKG3

Parameter	Value
Supply voltage	220-240 V
Frequency	50/60 Hz
Total burner output	5.0 kW
Power rating	20 W
Fuse protection	1 x 0.5 A
Gas connection	1/2" internal thread
Dimensions (width x depth x height)	
cooktop	370 x 540 x 73 mm
pan support high-power burner	270 x 270 x 25/50 mm
pan support normal burner	235 x 235 x 25/50 mm
Weight (incl. accessories/packaging)	11.5 kg
Cooktop	
Power levels	1-9, P
Heat retention levels	3
Front high-power burner	800-3000 W
Normal rear burner	550-2000 W
Total nominal connection values	5.00 kW
G20/20 mbar:	0.449 m ³ /h
Cooktop energy consumption G20/20 mbar	
Front high-power burner	850 - 3000 W 60,0 %
Normal rear burner	700 - 2000 W 60,0 %
Total (average)	60,0 %

Tab. 3.1 Technical data

Additional technical data for Australia and New Zealand (AUS/NZS):

Total nominal connection values for natural gas/
1.0 kPa test point pressure: 19.5 MJ/h

Cooktop energy consumption AUS/NZS natural gas/
1.00 kPa test point pressure:

High power front burner 12.0 MJ/h
Normal back burner 7.5 MJ/h

Appliance dimensions

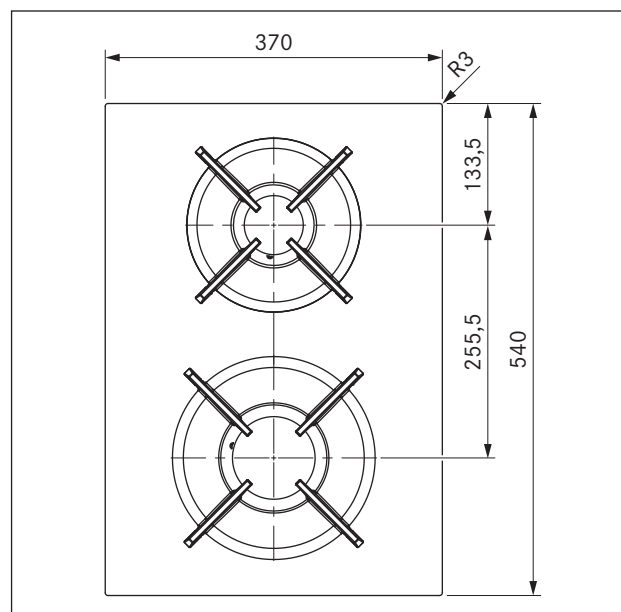

Fig. 3.1 PKG3 appliance dimensions from above

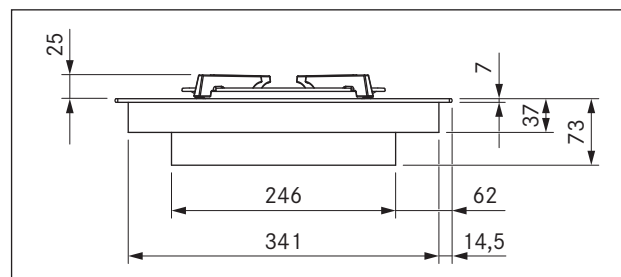

Fig. 3.2 PKG3 appliance dimensions front view

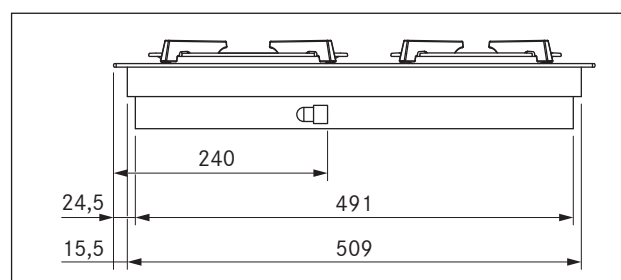

Fig. 3.3 PKG3 appliance dimensions side view

3.2 BORA Professional 3.0 control knob dimensions

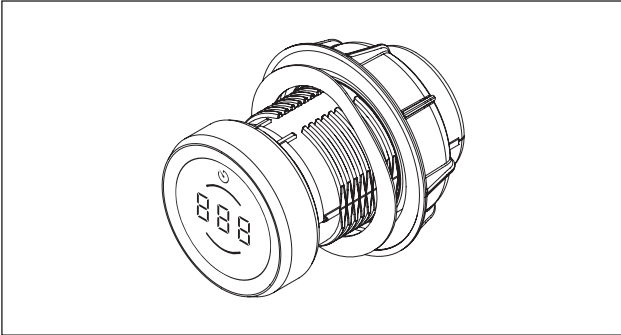

Fig. 3.4 Control knob

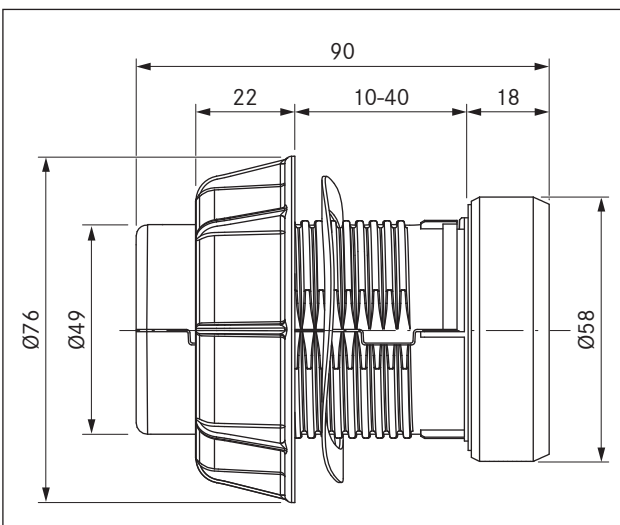

Fig. 3.5 Control knob dimensions

4 Appliance description

- Observe all safety and warning information during operation (see the Safety chapter).

4.1 Control knob

How it works

The cooktop extractor and cooktops are operated with a control knob. The power levels and functions are controlled by turning the knob ring and pressing the touch surface.

- i** How it works and its functions are described in more detail in the Operation chapter.

Structure

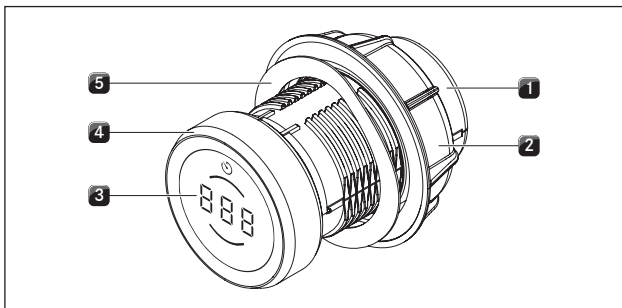

Fig. 4.1 Control knob structure

- [1] Knob housing
- [2] Universal nut
- [3] Control knob display
- [4] Knob ring
- [5] Wave spring

Operating elements

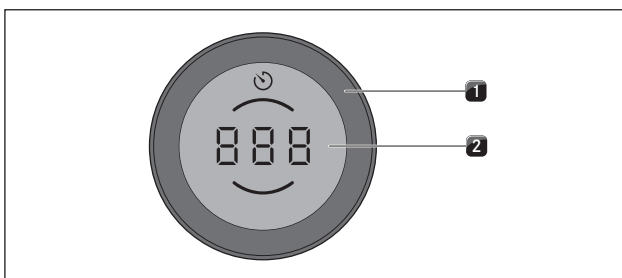

Fig. 4.2 Control knob operating elements

- [1] Knob ring
- [2] Touch surface

Control knob display

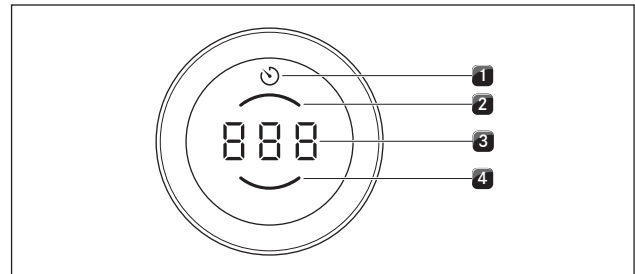

Fig. 4.3 Control knob display elements

- [1] Timer/egg timer indicator
- [2] Rear cooking zone indicator
- [3] Multi-function display
- [4] Front cooking zone indicator

Control knob assignment

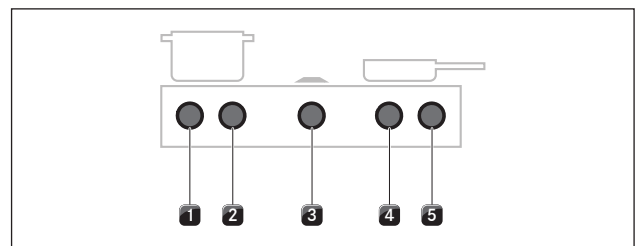

Fig. 4.4 Control knob assignment

- [1] Control knob for left cooktop, front cooking zone
- [2] Control knob for left cooktop, rear cooking zone
- [3] Control knob for cooktop extractor
- [4] Control knob for right cooktop, front cooking zone
- [5] Control knob for right cooktop, rear cooking zone

4.2 Cooktop appliance description

Display and symbols

- i** The power levels and cooking functions of each cooking zone are shown in the control knob display on the corresponding control knob.

Control knob display

Indicator	Meaning
□	Cooktop is switched off
1 - 9	Power levels
P	Power setting
H	Residual heat indicator
L	Childproofing feature
—U/—U/—U	Heat retention levels active
🕒	Timer function active
R	Automatic heat up function
e.g. R5	Automatic heat up function active
⌂	Configuration menu
E...	Error message (see the Troubleshooting chapter)

Tab. 4.1 Control knob display

Layout and size of the cooking zones

Gas cooktop PKG3

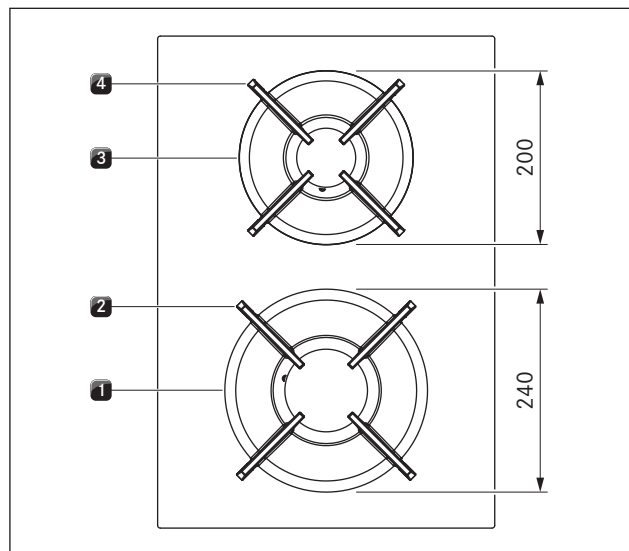

Fig. 4.5 Layout of gas cooktop PKG3 and cooking zone dimensions

- [1] High-power front burner
 [2] Front pan support
 [3] Normal back burner
 [4] Rear pan support

4.2.1 How gas cooktop PKG3 works

If a cooking zone is switched on, the flame generates heat, which directly heats the base of the cookware. The gas flame is controlled by a highly accurate electronic gas control system (e-gas system). Among other things, servomotors are used to accurately control each gas burner. These servomotors calibrate themselves from time to time and typical humming noises can be heard that are totally normal and do not constitute a malfunction.

The advantage of this electronic gas control system is the optimum, repeatable heat regulation, which means that the selected power levels are identical in every cooking session. In addition, a clean, constantly increasing flame is formed at every power level. Furthermore, if necessary, it can be automatically reignited. This control ensures that the numerous operating functions of the cooktop can be adjusted using the control knobs. The power is controlled via power levels 1-9 and P.

Power levels

The power output of gas cooktops results in food being heated quickly. In order to avoid burning food, slight adjustment is needed in comparison to conventional cooking systems when selecting the power level.

Activity	Power levels
Keeping cooked meals warm	1 - 2
Browning chopped vegetables, fried eggs, veal, poultry	3 - 5
Grilling prawns, corn on the cob, schnitzel, beef, fish or burgers	5 - 7
Bringing large amounts of liquid to the boil, searing steaks	8 - 9
Heating up water	P

Tab. 4.2 Recommendations for power levels

The specifications provided in the table are standard values.

Suitable cookware



Cookware with this symbol is suitable for gas cooktops.

- i** The heating and heat-through times for the cookware base, as well as the cooking results, are significantly influenced by the structure and material of the cookware. Cookware with a thick base ensures more even heat distribution. In the case of a thin base there is a risk of the food becoming overheated in places. The cooktop may also become damaged.
- i** Take special care not to overheat the cookware. Never heat empty cookware. The base can become deformed.
- i** Cookware with an uneven base may tip over. A slight wobble can never be completely ruled out.

Suitable cookware is made of:

- copper
- stainless steel
- aluminium
- cast iron

► Adhere to the dimensions in the table:

Burner position	Recommended pan diameter	Minimum pan diameter
Normal burner	140–200 mm	120 mm
High-power burner	180–240 mm	160 mm

Tab. 4.3 Pan diameters

i Only use cookware with a diameter that is within the given dimensions (see the Suitable cookware chapter). If the diameter is too large, the hot gases flowing outwards from under the base may damage the worktop or any non-heat-resistant wall, e.g. with panelling, as well as part of the cooktop and the cooktop extractor. Bora shall not be held liable for any such damage.

4.3 Safety devices

Safety shut-down

If an appliance is switched on but is not used for a predefined time, it is automatically switched off.

Cooktops

Each cooking zone is switched off automatically when the cooking zone exceeds the maximum operating duration on one power level or heat retention level. H is displayed (Residual heat indicator).

PKG3:	
Power levels	Safety shut-down after hours:minutes
I	8:24
2	6:24
3	5:12
4	4:12
5	3:18
6	2:12
7	2:12
8	1:48
9	1:18
P	0:20

Tab. 4.4 Safety shut-down on the different power levels

i After 20 minutes, the power setting is automatically switched back to power level 9.

PKG3:	
Heat retention level	Switch off after hours:minutes
1 (_)	8:00
2 (=)	8:00
3 (≡)	8:00

Tab. 4.5 Safety shut-down on the different heat retention levels

► Switch the cooking zone back on if you want to put the cooking zone back into operation (see the Operation chapter).

Residual heat indicator

i While H is displayed (residual heat indicator), do not touch the cooking zone or place any heat-sensitive objects on top of it. Risk of burns and fire!

After switching it off, the cooking zone remains hot.

H is displayed (Residual heat indicator).

After a sufficient cooling period the indicator will go out

Overheating protection

i If the cooktop overheats, the power is reduced or the cooktop is switched off completely.

The appliance is fitted with overheating protection. The overheating protection can be triggered if:

- cookware is heated up empty;
 - oil or fat is heated on high power;
 - a hot cooking zone is switched on again after a power cut.
- Whilst the overheating protection is active, one of the following steps is taken:
- the activated power setting is switched back to the previous level;
 - the power setting P can no longer be switched on;
 - the set power level is reduced;
 - the cooktop switches off completely.

After a sufficient cooling period, the cooktop can be used again.

Childproofing feature

i If a single cooktop is operated without a cooktop extractor, removal of the knob ring can prevent the appliance from being switched on accidentally or without permission.

5 Installation

- i** Assembly, installation and commissioning must always occur in line with national laws, regulations and standards.
 - i** The work must be performed by qualified specialists who know and comply with the additional regulations of the local energy supply companies.
 - i** The appliance must only be used in well-ventilated rooms.
- ▶ Observe all safety and warning information (see the “Safety” chapter).
 - ▶ Follow the enclosed manufacturer’s information.
 - ▶ Before connecting the appliance, check that the appliance settings comply with local connection requirements (gas type and pressure).
 - ▶ Do not leave small children unattended near the appliance!

5.1 General installation instructions

- i** The appliances must not be installed above cooling devices, dishwashers, stoves, ovens, washing machines or dryers.
- i** The contact surfaces of the worktops and wall sealing strips must be made of a heat-resistant material (up to approx. 100°C).
- i** Worktop cut-outs must be moisture-sealed using suitable means and, where necessary, fitted with a thermal insulator.
- i** External devices may only be connected to the cooktop extractor connections provided.
- i** Extremely bright lights aimed directly at the appliances can cause colour variations in the appliances and are thus to be avoided.

General installation instructions for cooktops

- i** To ensure that the cooktops perform optimally at all times, there must be sufficient ventilation beneath the cooktops.
- i** The performance of the cooktops is affected or the cooktops overheat if the warm air beneath the cooktops cannot escape.
- i** If a cooktop overheats, the power is automatically reduced or the cooktop is switched off completely (see “Overheating protection”).
- i** If cable protection (false floor) is planned beneath the appliance, this must be fitted so it does not obstruct ventilation.

Additional installation notes for Australia and New Zealand (AU/NZ):

- i** The gas hose must be inspected every 5 years and replaced if necessary. The gas hose must meet the requirements of AS/NZS 1869.

5.2 Checking the scope of delivery

- ▶ Make sure the delivery is complete and check it for damage.
- ▶ If there are any missing or damaged parts, please notify the BORA After Sales Service.
- ▶ Do not under any circumstances install parts which are damaged.
- ▶ Dispose of transport packaging in the proper manner (see the “Decommissioning, disassembly and disposal” chapter).

Name	Quantity
Cooktop	1
Control knob	2
Operating and installation instructions	1
Cooktop mounting screws	4
Height adjustment plate set	1
Cooktop mounting straps	4
Control knob cable	2
Cooktop to cooktop extractor communication cable	1
Special scope of delivery for glass ceramic cooktops	
Glass ceramic cleaning instructions	1
Special scope of delivery for gas cooktops	
Cast-iron grate	2
Nozzle set G20/20 mbar natural gas PKGDS2020	1
Cylindrical/conical transition piece	1
Seal	1
Special scope of delivery for Australia and New Zealand:	
Gas regulator 1,00 kPa with test point for natural gas (NG)	1
Flexible gas connection hose, length 500 mm, 1/2" external thread (EN14800)	1
Test point adapter for liquid gas (LPG)	1
Nozzle set G20/10 mbar (NG/1.0 kPa) – pre installed	1
Nozzle set G31/27,5 mbar (ULPG/2.75 kPa)	1

Tab. 5.1 Scope of delivery of the cooktops

5.3 Tools and aids

The following tools are required to correctly install the appliance:

- pencil
- tape measure or folding metre stick
- standard or cordless drill with Ø 50 mm Forstner bit
- black, heat-resistant silicone sealant
- slotted screwdriver
- size 20 Torx screwdriver

5.4 Assembly instructions

5.4.1 Safety clearances

► Maintain the following safety clearances:



Abb. 5.1 Minimum distance

- [1] Minimum clearance of 50 mm at the back from the worktop cut-out to the rear edge of the worktop.
- [2] Minimum clearance of 300 mm from the left and right of the worktop cut-out to the adjacent cabinet or wall.
- [3] Minimum clearance of 650 mm between the worktop and the wall unit.

5.4.2 Minimum installation dimensions (standard set-up)

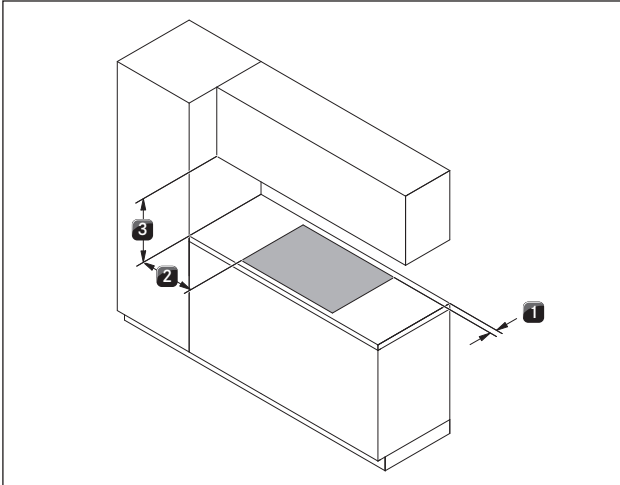

Abb. 5.2 Minimum installation dimensions for standard set-up of PKA3/PKA3AB



Abb. 5.3 Appliance installation dimensions for standard set-up of PKA3/PKA3AB with round silencer USDR50

5.4.3 Worktop and kitchen units

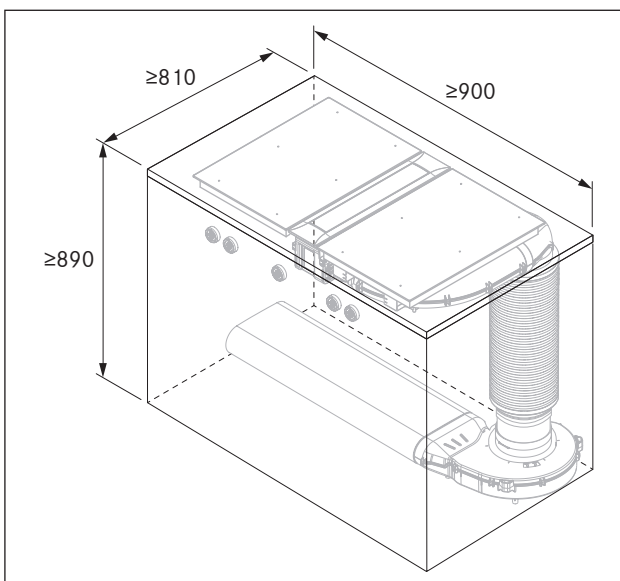
- Create the worktop cut-out taking into account the specified cut-out dimensions.
- Make sure that the cut surfaces of the worktops are properly sealed.
- Comply with the instructions of the worktop manufacturer.
- Cross bars on the kitchen unit in the area of the worktop cut-out may need to be removed.
- No false floor is necessary below the cooktop. If cable protection (false floor) is planned, the following must be taken into account:
 - it must be fitted in such a way that it can be removed for maintenance work;
 - to ensure sufficient cooktop ventilation, a minimum distance of 15 mm to the bottom edge of the cooktop is to be observed.
- The drawers and/or shelves in the floor unit must be removable.
- For correct installation, the drawers of the floor unit must be shortened depending on the installation situation.

5.4.4 Special installation instructions for gas cooktop PKG3

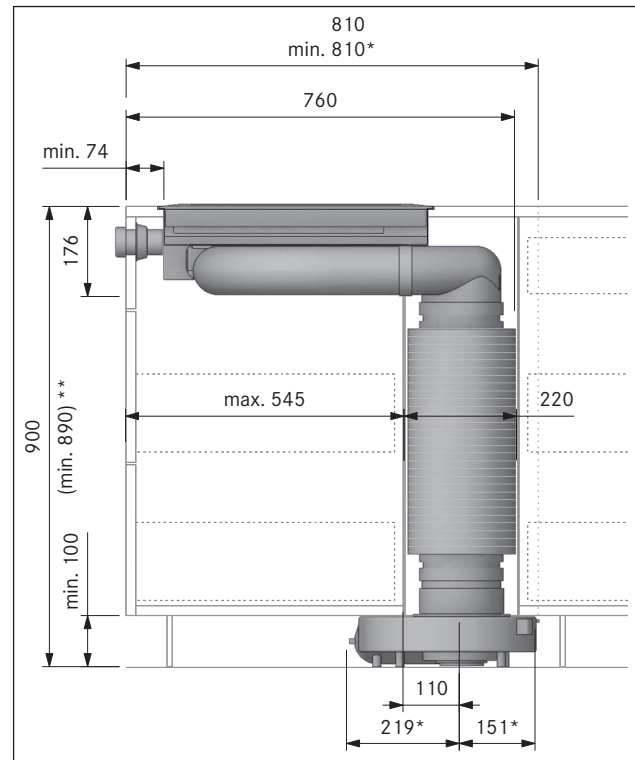
- i** Taking into account the applicable valid regulations, the cooktop must be connected to the gas line with an upstream stopcock.

- i** The hose connection must be laid in such a way that it is not subject to deformation, buckling or abrasion.
- i** The stopcock and gas supply pipe connections must be accessible.
- i** The pressure regulator must correspond to the set gas type and set gas pressure and must meet local and legal requirements.
- i** The gas connection hose line must not come into contact with smoke or the flue outlet of an oven.
- i** The hose must not come into contact with hot surfaces on the cooktop or other appliances.

Positioning of the gas cooktop PKG3 with two cooktop extractors

If the gas cooktop is used in a model with two cooktop extractors, it is to be installed at the side. If installed between the cooktop extractors, the pull of air from both sides may affect the flames.



Abb. 5.4 Position of the PKG3 with two cooktop extractors

Air supply for gas cooktop PKG3

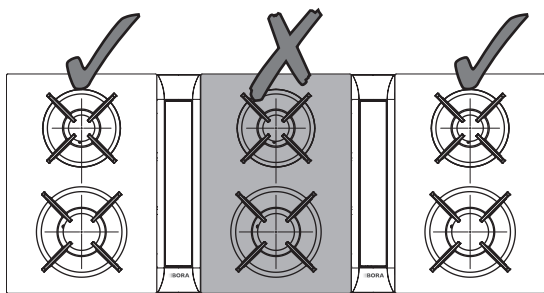

Abb. 5.5 Air supply at front of the unit

- [1] Air supply via the front of the unit (opening cross-section $\geq 50 \text{ cm}^2$)
- [2] Optional cable protection (shortened)

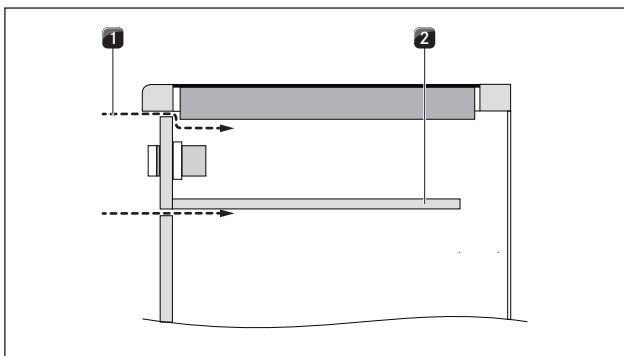

Abb. 5.6 Plinth area air supply

- [1] Optional cable protection (shortened)
- [2] Air supply via the plinth area (opening cross-section $\geq 150 \text{ cm}^2$)

i To ensure a sufficient air supply, an opening cross-section of at least 50 cm^2 is recommended in the front of the kitchen unit, or an opening cross-section of at least 150 cm^2 in the plinth area.

► Make sure that the area below the cooktop has a sufficient air supply.

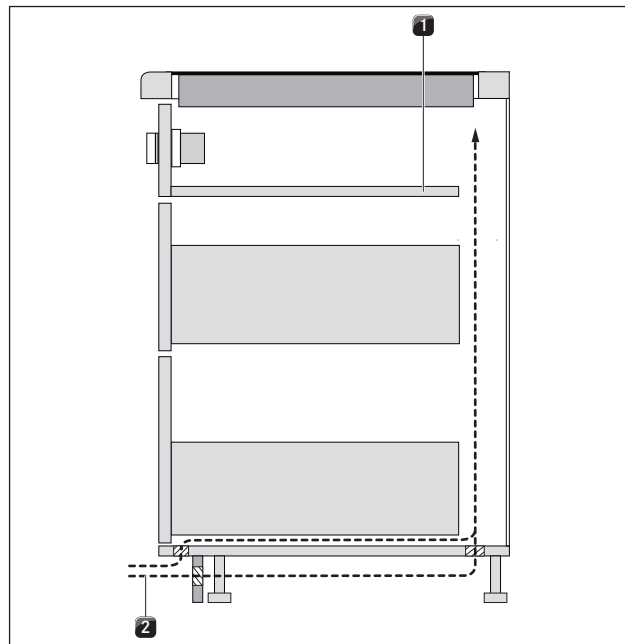
5.4.5 Recirculation when using the cooktop extractor as a recirculation system

In the case of recirculation systems there must be a return flow aperture in the kitchen units:

- $>1000 \text{ cm}^2$ (per air cleaning box) in combination with gas cooktop PKG3

i If several extractor systems are operated in recirculation mode, the return flow aperture for each air cleaning box must be calculated accordingly. Example: 2 recirculation systems = $2 \times (>1000 \text{ cm}^2)$

For recirculation, the necessary return flow aperture can be created using a shortened plinth. A slatted plinth with at least the minimum opening cross-section can also be used.





Abb. 5.7 Recirculation design example (kitchen island + PKG3 + PKAS3 + air cleaning unit)

- [1] Gas cooktop PKG3
- [2] Cooktop extractor PKAS3 (recirculation)
- [3] Air cleaning box (ULBF, ULB3)
- [4] Recirculation return flow aperture (total opening cross-section $\geq 1000 \text{ cm}^2$ per air cleaning unit)

► Ensure that the return flow aperture is large enough

i If the gas flame goes out or there is a high burner flame delay, the return flow aperture must be enlarged.

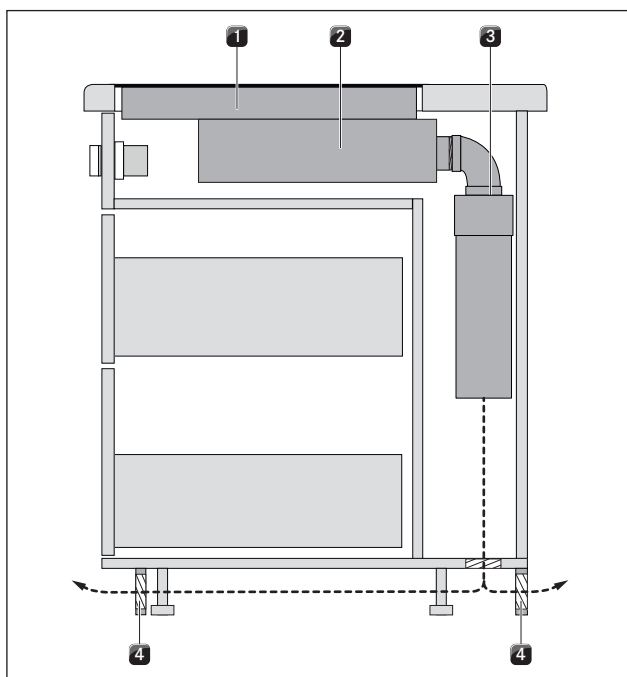
5.5 Cut-out dimensions

i All dimensions are shown from the front edge of the front panel.

Worktop overhang



Abb. 5.8 Worktop overhang

► Please note the worktop overhang x when creating the worktop cut-out. Applies to flush installation and surface mounting.

i In the case of cooktop extractor PKA3/PKA3AB combined with straight duct piece PKA1FEV, flush installation is also possible in a worktop with a depth $\geq 650 \text{ mm}$.

5.5.1 Flush installation

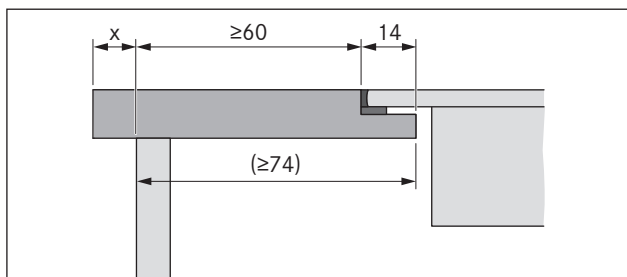

Abb. 5.9 Cut-out dimensions for flush installation



Abb. 5.10 Rebate dimensions for flush installation

Cooktops/cooktop extractor	A in mm	B in mm	
	1/0	374	346
	1/1	485	457
	2/1	856	828
	3/2	1338	1310
	4/2	1709	1681

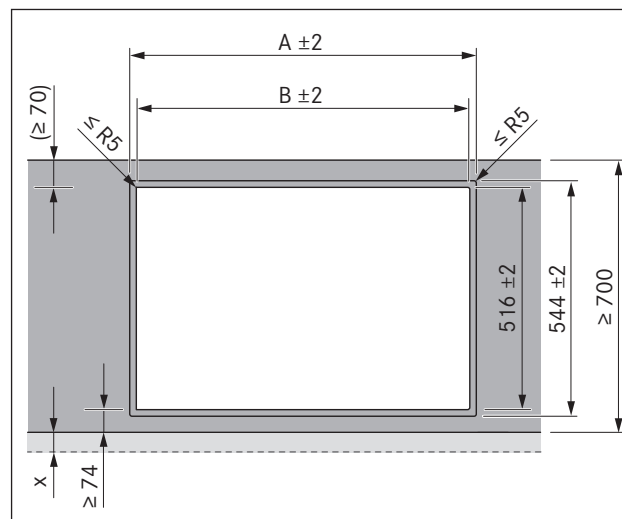
Tab. 5.2 Cut-out dimensions of the appliance combinations in the case of flush installation

5.5.2 Surface mounting

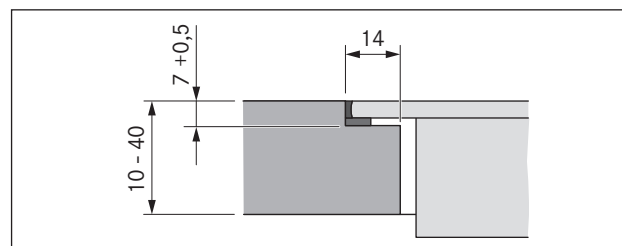

Abb. 5.11 Cut-out dimensions for surface mounting



Abb. 5.12 Overlay dimensions for surface mounting

Cooktops/cooktop extractor		B in mm
	1/0	346
	1/1	457
	2/1	828
	3/2	1310
	4/2	1681

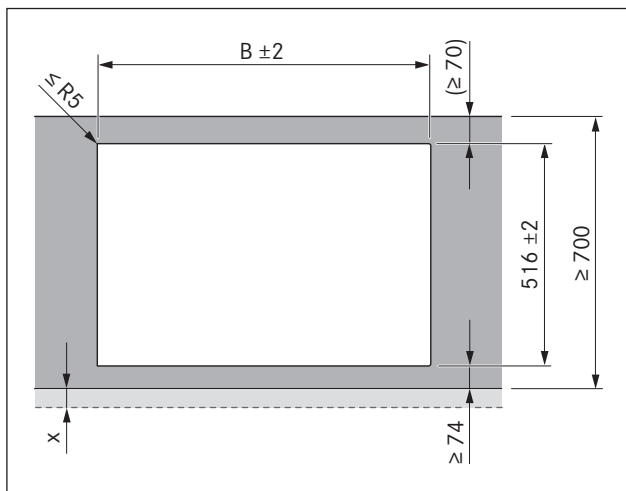
Tab. 5.3 Cut-out dimensions of the appliance combinations in the case of surface mounting

5.6 Installing the control knob in the floor unit front panel

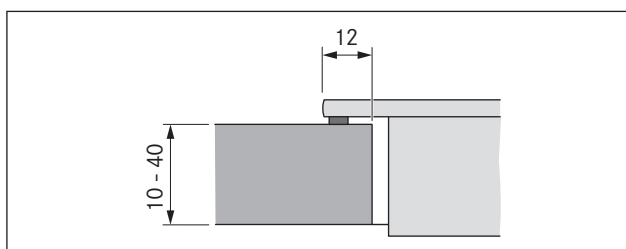

Abb. 5.13 Installed control knob

► Pre-drill all bore holes to prevent tearing out the fixed front panel.

5.6.1 Cooktop bore holes

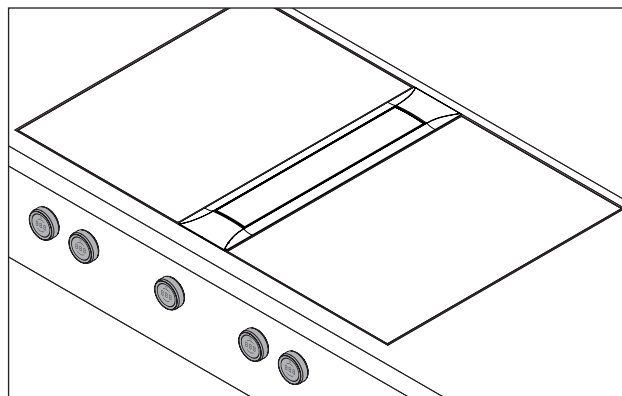

Abb. 5.14 Cooktop drilling pattern

- [1] Cooktop
- [2] Worktop
- [3] Fixed front panel

5.6.2 Example bore holes

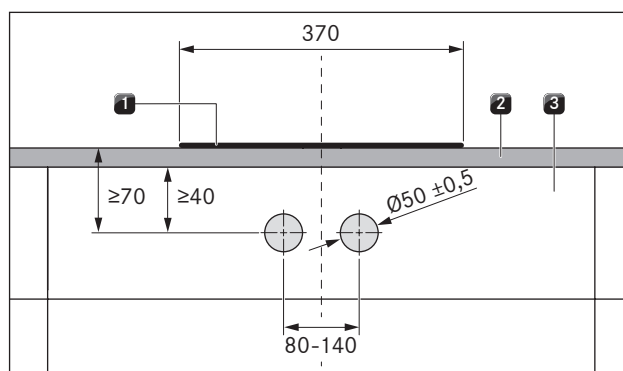

Abb. 5.15 Drilling pattern for 2 cooktops, 1 cooktop extractor and 2 sockets

- [1] Boreholes for socket (x 2 external)
- [2] Bore holes for control knobs (x 5)
- [3] Cooktop (x 2)
- [4] Cooktop extractor
- [5] Worktop
- [6] Fixed front panel

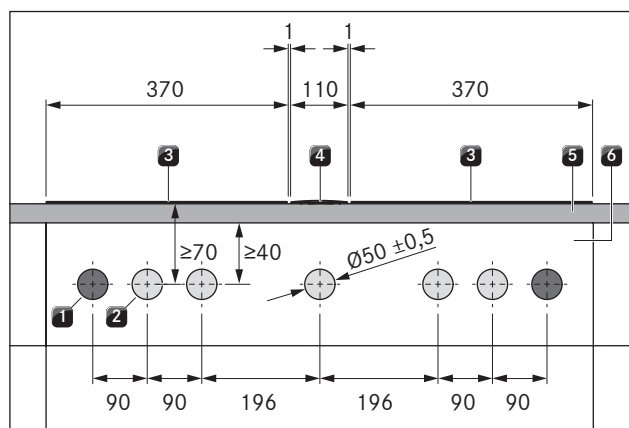

Abb. 5.16 Drilling pattern for 3 cooktops, 2 cooktop extractors and 2 sockets

- [1] Boreholes for socket (x 2 external)
- [2] Bore holes for control knobs (x 8)
- [3] Cooktop (x 3)
- [4] Cooktop extractor (x 2)
- [5] Worktop
- [6] Fixed front panel

5.6.3 Fitting the control knob

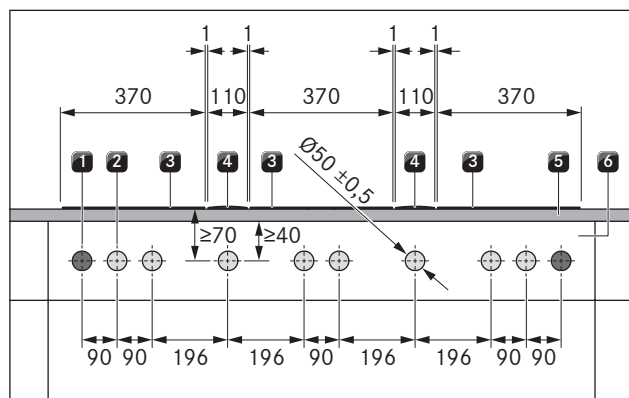

Abb. 5.17 Structure of control knob

- [1] Knob housing
- [2] Universal nut
- [3] Sticker
- [4] Knob ring
- [5] Wave spring

i In the case of steel fronts, wave springs must not be used. The corresponding installation steps are to be omitted.

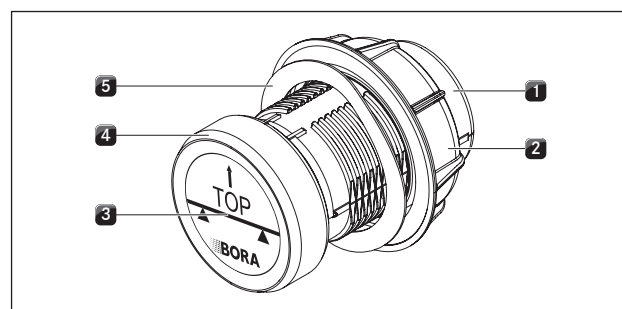

Abb. 5.18 Fitting the control knob



Abb. 5.19 Wave spring when installation is complete

- ▶ Remove the knob ring [4].
- ▶ Unscrew the universal nut [2].
- ▶ Remove the wave spring [5].
- ▶ Insert the knob housing [1] from the front through the hole in the panel.
- ▶ Attach the wave spring [5] to the knob housing [1] from the rear (not in the case of steel fronts).
- ▶ Screw the universal nut [2] onto the knob housing [1] from the rear and tighten a little.

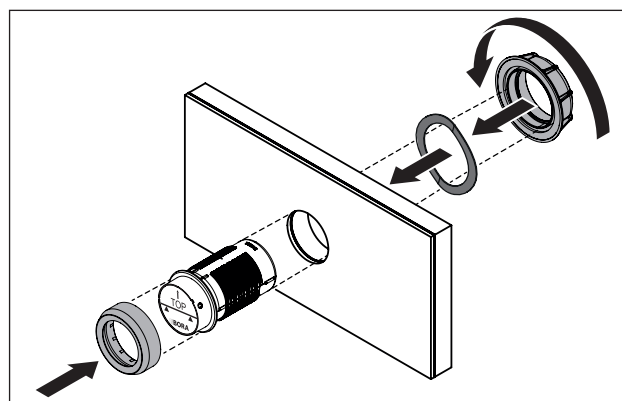
- ▶ Align the knob housing [1] so it is level.
- ▶ Tighten the universal nut [2].
- The wave spring (if used) must be pressed flat.
- ▶ Remove the sticker [3].
- ▶ Place the knob ring [4] on the knob housing [1].

5.7 Gas installation

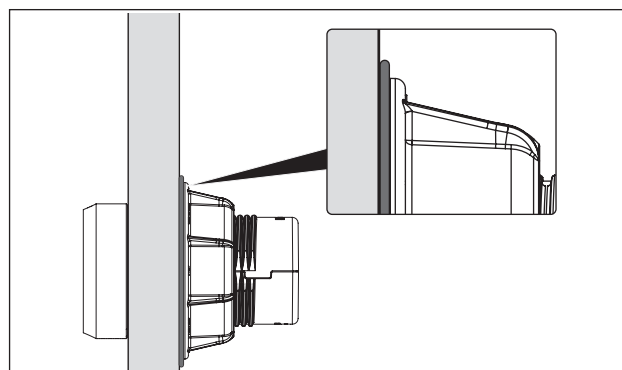
- i** Assembly, installation and commissioning must always occur in line with national laws, regulations and standards.
- i** The work must be performed by qualified specialists who know and comply with the additional regulations of the local energy supply companies.
- i** The gas must be connected before the cooktop is installed in the worktop.

Ventilation

This appliance is not connected to a flue gas evacuation device. It must be positioned and connected in accordance with the applicable installation conditions. Suitable ventilation measures must be particularly adhered to.

- ▶ Always ensure there is sufficient ventilation when operating the appliance.

5.7.1 Gas connection



Abb. 5.20 Position of gas connection

The gas supply is connected to the appliance using a pre-installed elbow fitting with a 1/2" cylindrical internal thread. If, due to national regulations, a conical connection is required, the cylindrical/conical transition piece (provided) is to be used.

5.7.2 Connecting the gas supply

- ▶ Turn off the gas supply.
- ▶ Switch off the main switch/automatic circuit breaker before connecting the cooktop.
- ▶ Secure the main switch/automatic circuit breaker against being switched back on without permission.

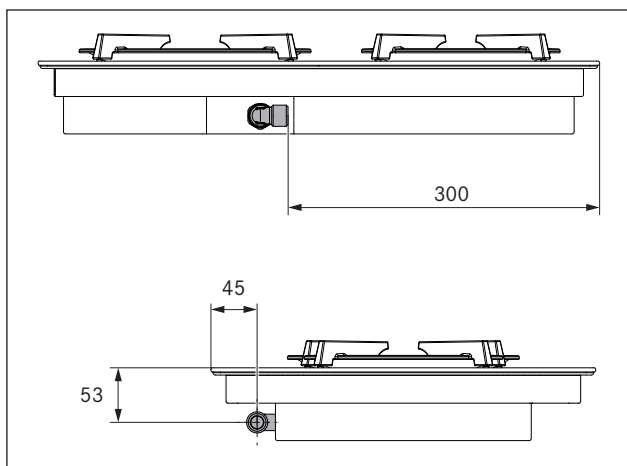
- ▶ Make sure the power to the appliance is disconnected.
- ▶ Check the gas type and gas pressure of the gas supply pipe.
- ▶ Ensure that the appliance is equipped with the correct nozzle type in order to guarantee a correct burner flame and safe operation.
- ▶ Remove the protective cap from the elbow fitting.
- ▶ Connect the appliance to the gas supply.
- ▶ Use suitable testing equipment to check all the connections between the cooktop and the gas connection. There must not be any leaks.
- ▶ Create a leak test record and give this to the user.

5.7.3 Additional installation notes for Australia and New Zealand (AU/NZ)

- i** Observe the requirements on the installation of the appliance pursuant to AS/NZS 5601.1: minimum clearance of the gas burner head from flammable surfaces.
- i** Installation must only be carried out by authorized personnel.
- ▶ In addition, adhere to the requirements of the currently applicable version of the regulations and AS/NZS 5601.1 .
- ▶ Further technical requirements are considered: AS/NZS 5263.1.1 Gas appliances - Domestic gas cooking appliances (AU/NZS).
- ▶ Check the different scope of delivery (see scope of delivery of the cooktops)

- The connection to a rigid and bend-resistant pipe must be established as specified in AS/NZS 5601.1.
- Pursuant to AS/NZS 1869 (certified to AS/NZS 1869), the connection to a hose for gas must have a diameter of 10 mm, a class B or D classification in accordance with AS/NZS 1869 and a maximum length of 1,200 mm in accordance with AS/NZS 5601.1.

Natural gas (NG)

If the cooktop is connected to a natural gas (NG) supply, a gas regulator must be installed with a test point. The gas regulator comes with the appliance.



Abb. 5.21 Gas regulator (NG)

- ▶ Attach the gas regulator to the gas cooktop connection.
- ▶ Note the gas flow direction of the gas regulator.

Liquid gas (LPG)

- i** When converting from NG to ULPG, the sticker in the enclosed pack must be attached.

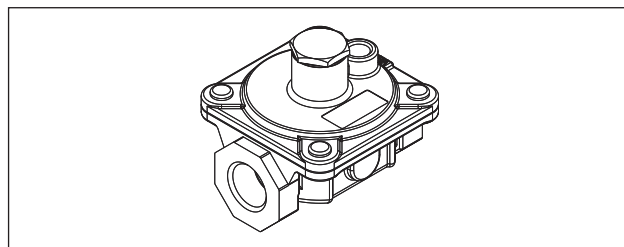
If the cooktop is attached to a liquid gas supply (LPG), the supply is controlled on the gas bottle. For this purpose, install only the test point adapter in the gas supply pipe. The test point adapter comes with the appliance.



Abb. 5.22 Test point adapter (LPG)

- ▶ Attach the test point adapter to the gas cooktop connection.

Check the gas pressure (LPG) as follows:

- ▶ Set the control knob to the 0 position.
- ▶ Close the gas supply.
- ▶ Unscrew the test point screw completely.
- ▶ Connect your measuring device to the test point connection.
- ▶ Open the gas supply.
- ▶ Set the gas pressure at the gas supply pipe (LPG pressure bottle) to 2.75 kPa.
- ▶ Ignite the burner (see the Operation section).
- ▶ Check the burner flame.
- ▶ Close the gas supply after successfully setting the pressure.
- ▶ Set the control knob to the 0 position.
- ▶ Shut off the measuring device from the test point.
- ▶ Securely screw the test point screw back into the test point adapter.
- ▶ Check that the screw is positioned correctly.

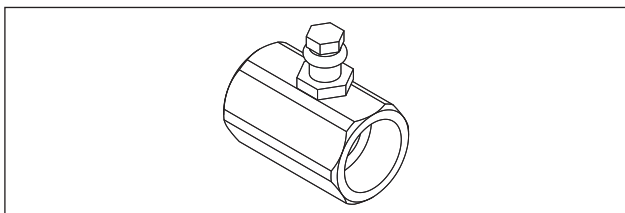
5.7.4 Changing the gas type

- ▶ Turn off the gas supply to the gas supply pipe.
- ▶ Switch off the main switch/automatic circuit breaker.
- ▶ Secure the main switch/automatic circuit breaker against being switched back on without permission.
- ▶ Make sure the power to the appliance is disconnected.

Changing the gas burner nozzle in the gas burner

- i** The burner nozzles, gas type and pressure may only be changed by a certified engineer or BORA service technician. They also assume responsibility for the proper gas installation and commissioning.
- i** The nozzles regulate the maximum gas throughflow for each burner and gas type/pressure.

- i** The gas cooktop is set by default to natural gas G20/20 mbar (pre-assembled). If another type of gas is used, the configuration menu on the cooktop must be adjusted accordingly.

- i** Use only stamped and approved nozzles.

Cat.	
I2E+	G20/G25: 20/25 mbar, BE, FR
I2E	G20:20 mbar, DE, LU, PL, RO
I2EK	G25.3: 25 mbar, NL
I2L	G25: 25 mbar, NL
I2ELL	G20/G25: 20/25 mbar, DE/LU
I2H	G20: 20 mbar, AT, CH, CZ, DK, EE, ES, FI, GB, GR, HR, IE, IT, LU, LT, LV, NO, PT, RO, SE, SI, SK, TR
I3+	G30/G31: 28-30/37 mbar, BE, CH, CY, CZ, ES, FR, GB, GR, IE, IT, LT, PT, SI, TR
I3B/P	G30/31: 30 mbar, BE, CY, CZ, DK, EE, FI, FR, GB, GR, HR, IT, LT, NL, NO, PL, PT, RO, SE, SI, TR
I3B/P	G30/31: 50 mbar, AT, CH, DE, FR, SK
I3P	G31:37 mbar, BE, CH, CZ, ES, FR, GB, GR, HR, IE, IT, LT, NL, PL, PT, SI, SK, TR
I 2E+3+	G20/G25: 20/25 mbar, G30/G31: 28-30/37 mbar, BE, FR
I 2EK3B/P	G25.3: 25 mbar, G30/31: 30 mbar, NL
I 2ELL3B/P	G20/G25/G30: 20/20/50 mbar, DE
I 2H3+	G20:20 mbar, G30/31: 28-30/37 mbar, CH, CY, CZ, ES, GB, GR, IE, IT, LT, PT, SI, SK, TR
I 2H3B/P	G20: 20 mbar, G30/G31: 30 mbar, CY, CZ, DK, EE, FI, GR, HR, IT, LT, NO, RO, SE, SI, SK, TR
I 2H3B/P	G20: 20 mbar, G30/31: 50 mbar, AT, CH, SK
I 2L3B/P	G25: 25 mbar, G30/31: 30 mbar, RO

Tab. 5.4 Overview of gas categories

AT	eingestellt:	natural gas H	I2H	20 mbar
BE	eingestellt:	Erdgas E+	I2E+	20 / 25 mbar
BE	ingesteld:	Aardgas E+	I2E+	20 / 25 mbar
BE	reglage:	Gaz naturel E+	I2E+	20 / 25 mbar
CH	eingestellt:	Erdgas H	I2H	20 mbar
CH	impostato per:	Gas metano H	I2H	
CH	impostato per:	Gaz naturel H	I2H	
CY	ενεργοποιημένη:	φυσικό αέριο H		20 mbar
CZ	nastaveno na:	Zemní plyn H	I2H	20 mbar
DE	eingestellt:	Erdgas E	I2H	20 mbar
DK	sat på:	Naturgas H	I2H	20 mbar
EE	sisse lülitatud:	Maagaas H	I2H	20 mbar
ES	ajustado:	Gas natural H	I2H	20 mbar
FI	asetettu:	Maakaasu H	I2H	20 mbar
FR	reglage:	Gaz naturel E+	I2E+	20 / 25 mbar
GB	set for:	Natural gas H	I2H	20 mbar
GR	ενεργοποιημένη:	φυσικό αέριο H	I2H	20 mbar

HR	uključeno:	Prirodni plin H	I2H	20 mbar
IE	set for:	Natural gas H	I2H	20 mbar
IS	sett á:	jarðgas H		20 mbar
IT	aggiustato a:	Gas naturale H	I2H	20 mbar
LT	nustatytas:	Gamtinés dujos H	I2H	20 mbar
LU	festgeluecht:	Natierlech Gas E		20 mbar
LV	ieslēgts:	Dabaszgāze H	I2H	20 mbar
MT	issettjat fuq:	Gass naturali H		20 mbar
NO	satt på:	Naturgass H	I2H	20 mbar
PL	ustawić:	Gaz ziemny E	I2H	20 mbar
PT	regulado para:	Gás natural H	I2H	20 mbar
RO	setat pe:	Gaz natural H	I2H, I2E	20 mbar
SE	sätt på:	Naturgas H	I2H	20 mbar
SI	nastavljen na:	Zemeljski plin H	I2H	20 mbar
SK	zapnuté:	Zemný plyn H	I2H	20 mbar
TR	ayarlamak:	Doğal gaz H	I2H	20 mbar

Tab. 5.5 Gas cooktop default settings

The stamp on the nozzles corresponds to the values in the nozzle table and can be found either on the top or side of the nozzles.

Gas type/gas pressure mbar	Ø SR burner/ normal burner	Ø R burner/ high-power burner
G20/20	104	125
G25/20	110	131
G20/13	115	149
G25/25 G25.3/25	104	131
G20/25	100	119
G30/37	69	85
G31/37		
G30/50 G30-50 mbar	62	78

Tab. 5.6 Nozzle table

Total nominal connection values for liquid gas:

Gas type	mbar	kW	g/h	m ³ /h
G30/G31	50	4.90	364	0.143
G30	29	5.00	364	0.143

Tab. 5.7 Liquid gas nominal connection values

Total nominal connection values for natural gas:

Gas type	mbar	kW	m ³ /h
G20	20	5.00	0.48
G25	25	5.10	0.55
G25.3	25	5.10	0.54
G20	13	5.00	0.48
G25	20	4.80	0.55

Tab. 5.8 Natural gas nominal connection values

Special nozzle table for Australia and New Zealand:

AUS / NZS		
gas type	Ø SR burner/ normal burner	Ø R burner
NG/1.0 kPa (G20/10)	1.22	1.55
ULPG/2.75 kPa (G31/27,5)	0.75	0.92

Tab. 5.9 Nozzle table (Australia and New Zealand) Total nominal connection values for U-LPG/ 2.75 kPa test point pressure: 18.6 Mj/h

Cooktop energy consumption AU/NZ - U-LPG/ 2.75 kPa test point pressure:
 High Power front burner 11.2 Mj/h
 Normal back burner 7.4 Mj/h

Total nominal connection values for NG/ 1.0 kPa test point pressure: 19.5 Mj/h

Cooktop energy consumption AU/NZ - NG/ 1.00 kPa test point pressure:
 High power front burner 12.0 Mj/h
 Normal back burner 7.5 Mj/h



Abb. 5.23 Gas burner structure

- [1] Burner cap
- [2] Burner head
- [3] Electric igniter
- [4] Safety thermocouple
- [5] Burner housing
- [6] Gas burner nozzle

- ▶ Remove the pan support.
- ▶ Remove the burner cap [1] from the burner head [2].
- ▶ Remove the burner head [2] from the gas outlet.

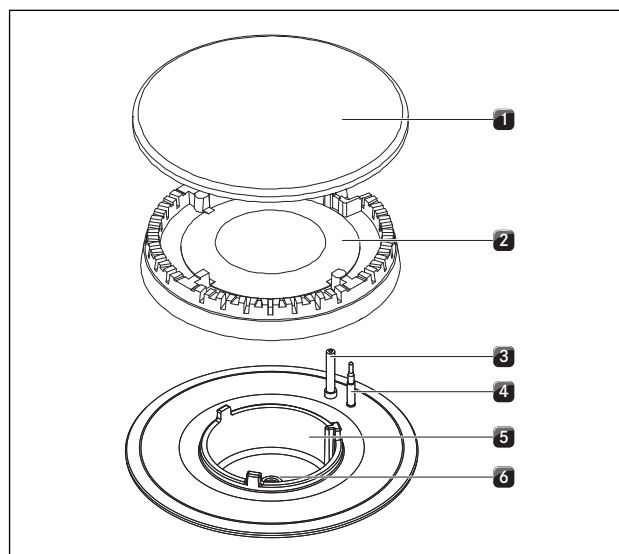

Securing the cooktop



Abb. 5.28 Mounting brackets

- [1] Mounting bracket
- [2] Washer
- [3] Screw

- ▶ Secure the appliance using the mounting brackets [1].
- ▶ Tighten the mounting brackets with the screw [3] using the washer [2] with max. 2 Nm.
- ▶ Verify that the alignment is correct.

5.8.2 Installation rotated by 180° (alternative installation variation)

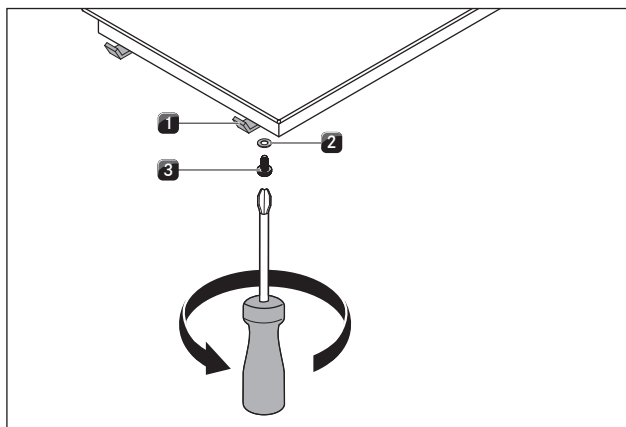
Installation rotated by 180°

- ▶ Rotate the cooktop 180°.



Abb. 5.29 Rotating the gas elbow fitting by 180°

- ▶ Rotate the gas elbow fitting 180° so that the supply can be connected to the rear.
- ▶ For the installation, proceed as described above.
- ▶ Change the installation direction in the cooktop extractor configuration menu (see “Configuration menu” in the cooktop extractor operating instructions).

i If installation is rotated by 180°, then the ports for the control knobs and the interface for the cooktop extractor are at the rear of the cooktops.

i Cables of sufficient length are provided.

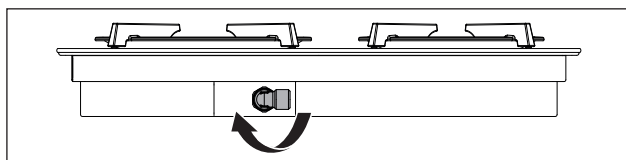
5.9 Establishing communication and power connection

- ▶ Observe all safety and warning information (see the “Safety” chapter).
- The plug for the mains supply cable must be accessible following installation.

● If the mains supply cable has been damaged this must be replaced.

i The appliance components are linked by the ribbon cable provided.

5.9.1 Connecting the control knobs

i Control knobs must only be connected to the ports provided on the appliance.



Abb. 5.30 Back of control knob with port

- [1] Port on the back of the control knob

- ▶ Connect the control knobs to the appliances.

Connecting the control knobs to the cooktop

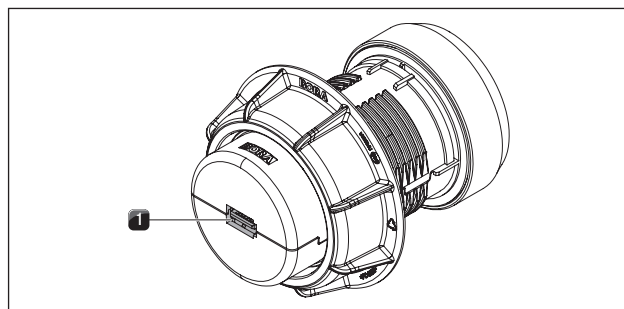
i In the normal set-up the ports are on the front of the cooktops.

i According to the default settings, the left control knob operates the front cooking zone (zone 1) and the right control knob operates the rear cooking zone (zone 2).



Abb. 5.31 Ports on the cooktop

- [1] Front cooking zone control knob port (zone 1)
- [2] Extractor electronics interface port
- [3] Rear cooking zone control knob port (zone 2)

Standard cooking zone connection

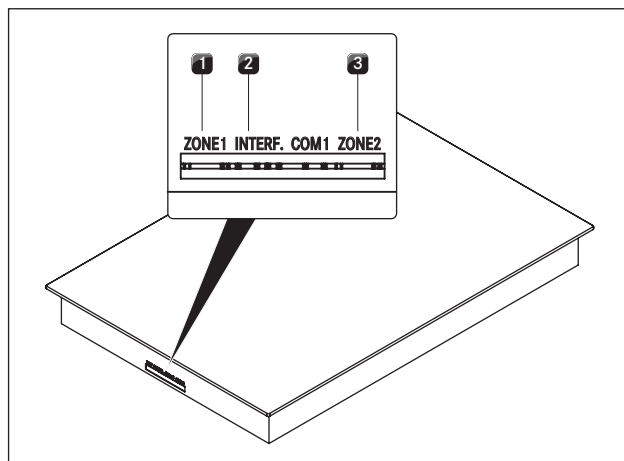

Abb. 5.32 Standard connection of appliances that connect at the front

- [1] Cooktop
- [2] Rear cooking zone (zone 2)
- [3] Front cooking zone (zone 1)
- [4] Rear cooking zone control knob (zone 2)
- [5] Front cooking zone control knob (zone 1)

Connecting the cooking zones when the cooktop is installed rotated by 180°

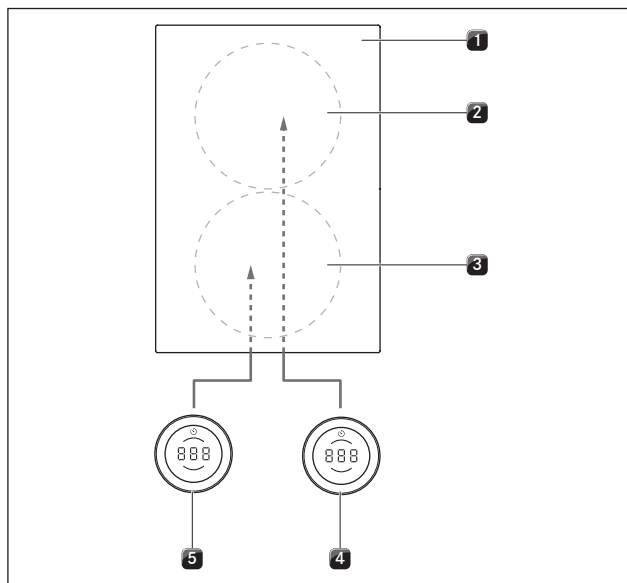

Abb. 5.33 Connecting the cooking zones when the cooktop is installed rotated by 180° and the ports are on the front of the appliance

- [1] Cooktop
- [2] Rear cooking zone (zone 1)
- [3] Front cooking zone (zone 2)
- [4] Rear cooking zone control knob (zone 1)
- [5] Front cooking zone control knob (zone 2)

- ▶ Connect the port on the back of the left control knob [5] to the “zone 2” port on the cooktop [1].
- ▶ Connect the port on the back of the right control knob [4] to the “zone 1” port on the cooktop [1].
- ▶ Using the configuration menu, set the correct allocation of the cooking zones in the control knob display (see “Configuration menu” – “0° or 180° installation”).

5.9.2 Establishing contact between the cooktop extractor and cooktops

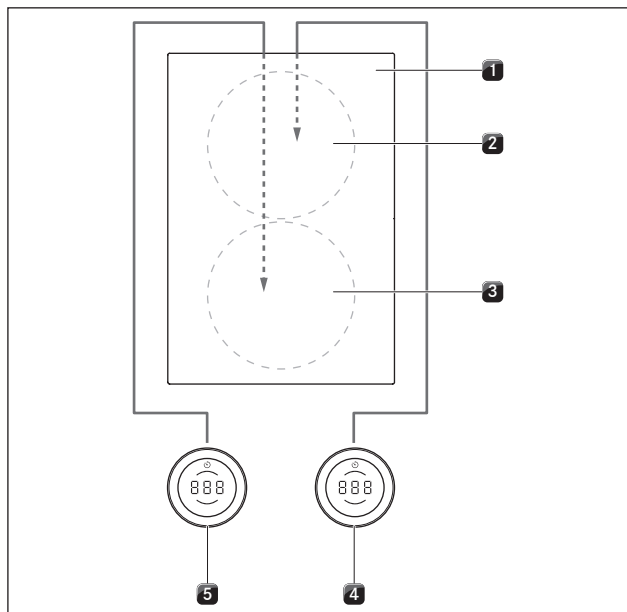

Abb. 5.34 Establishing contact between the cooktop extractor and cooktops

- [1] Cooktop extractor communication cable port for left cooktop
- [2] Cooktop extractor communication cable port for right cooktop
- [3] Cooktop communication cable port
- [4] Cooktop to cooktop extractor

- ▶ Using the communication ports provided, connect the cooktop extractor [1]/[2] to the cooktop or cooktops [3].
- ▶ Only use the cables supplied in the scope of delivery.

i The full range of functions on the appliances will only be available if the cooktop extractor and cooktops are connected correctly.

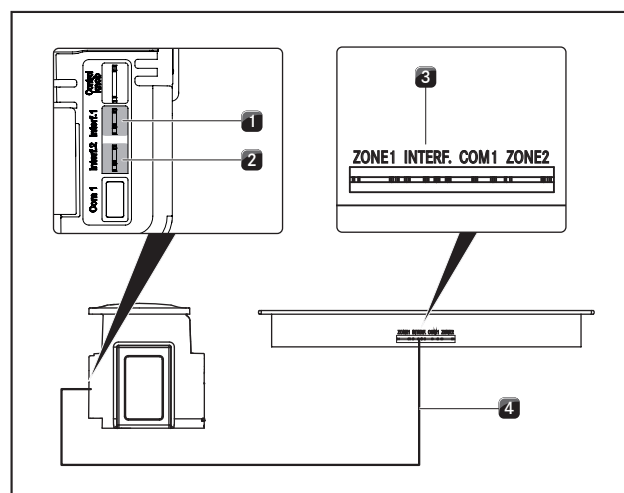
5.9.3 Connecting the power supply

i Assembly, installation and commissioning must always occur in line with national laws, regulations and standards.

i The work must be performed by qualified specialists who know and comply with the additional regulations of the local energy supply companies.

i The appliances may only be connected to the mains power supply by certified specialists. The specialist also assumes responsibility for the proper installation and commissioning.

Connecting the cooktop to the power supply

The power supply cable to be used (already pre-installed) must comply with certain, appliance-specific requirements (see table “Fuse protection and minimum cross-section”).

- i** A damaged power supply cable must be replaced by another suitable power supply cable. This may only be done by an authorised member of the After Sales Service team.

Power supply cable requirements and connection diagram

Connection	Fuse protection	Wire cross section	Power supply cable
1-phase connection	1 x 16 A	1.5 mm ²	Type H05VVH2-F

Tab. 5.10 Fuse protection and minimum cross-section



Abb. 5.35 1-phase connection diagram

Connecting the cooktop to the mains

- ▶ Switch off the main switch/automatic circuit breaker before connecting the cooktop.
- ▶ Secure the main switch/automatic circuit breaker against being switched back on without permission.
- ▶ Make sure the power to the appliance is disconnected.
- ▶ Only connect the cooktop using a permanent connection to a power supply cable.
- ▶ Check that installation has been carried out correctly.
- ▶ Switch on the main switch/automatic circuit breaker.
- ▶ Put the cooktop into operation (see the “Operation” chapter).
- ▶ Check that all the functions are working correctly.

5.10 Basic configuration

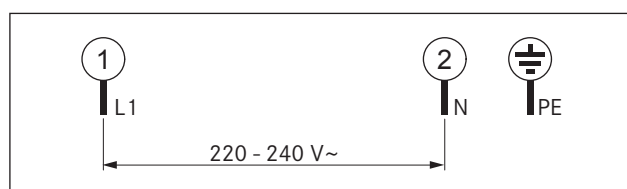
When installation is complete, you must carry out the basic settings (these settings can be changed at any time later on).

- i** You can see precise instructions on the basic configuration and all necessary information in the “Configuration menu” chapter of the operating instructions.

5.10.1 Gas configuration

- i** The burner nozzles, gas type, gas pressure and gas characteristic curve may only be changed by a certified engineer or BORA service technician. They also assume responsibility for the proper gas installation and commissioning.
- i** Gas characteristic curve A must not be used in the case of liquid gas (G30/31).

- i** It is important that the gas type, gas pressure and characteristic curve are set correctly to ensure safe, failure-free operation of the gas cooktop.

- i** You can see detailed information on the configuration menu in the operating instructions.

- ▶ Enter the settings in the gas configuration menu (see “Configuration menu” chapter).

5.11 Initial operation

- i** You will find detailed information on operating the BORA Professional 3.0 system in the operating instructions (see “Functions and operation” chapter).

- ▶ Ensure that all appliances are connected correctly and connected to the power supply (fused) prior to initial operation.
- Exception: During initial operation, the kitchen fitter may use a temporary power supply for the control unit in order to carry out the basic configuration (e.g. using the site power supply during the building phase).
- The settings made are saved and will not be affected when the system is disconnected from the mains.
- The final mains connection to the appliances may only be set up by certified specialists.

5.11.1 Using the gas cooktop for the first time

- i** Initial operation is possible when the gas cooktop has been fully installed and configured.

- ▶ Switch the cooking zone on. The electronic gas regulator will calibrate itself (humming noises) and then the gas flame will automatically ignite in the selected cooking zone. The gas flame will burn steadily and evenly.

Using the gas cooktop together with the cooktop extractor for the first time

- ▶ Switch the cooktop extractor to the maximum power level.
- ▶ Switch all cooking zones to the minimum power level. The electronic gas regulator will calibrate itself (humming noises) and then the gas flame will automatically ignite in the selected cooking zone. The gas flame will burn steadily and evenly (no reignition). The gas flame will be slightly affected by the cooktop extractor (airflow) – this is normal.
- ▶ Check all the functions of the cooktop extractor and cooktop are working correctly.
- ▶ Check the burner flame is working correctly, particularly when the cooktop extractor is in use.

- i** If the gas flame goes out, is excessively affected by the extractor and/or the flame is not as it should be (e.g. soot production, flame blowback, etc.), the characteristic curve must be increased, as well as the ventilation in exhaust air mode, if necessary, or the return flow aperture in recirculation mode.

Faults during initial operation

When operating for the first time or after a prolonged period without use or when the liquid gas bottles have been changed, faults are possible:

The burner does not ignite. The control knob emits an acoustic signal and the power level display flashes.

There may be air in the gas pipe.

- ▶ Try to ignite it again by touching the control knob.

The burner does not ignite and the cooktop does not react.

The electronic gas regulator must be recalibrated.

- ▶ Using configuration \square H _ reset the gas regulator.

The control knob display shows an error message (e.g. E001).

- ▶ Using configuration \square H _ reset the gas regulator.

5.12 Function test

- ▶ Carry out a thorough function test on all appliances in accordance with se.,5.11.1 Using the gas cooktop for the first time“me”
- ▶ In the event of error messages, see the “Troubleshooting” chapter in the operating instructions.

5.13 Sealing the appliances



Abb. 5.36 Silicone sealant for flush installation

[1] Black, heat-resistant silicone sealant

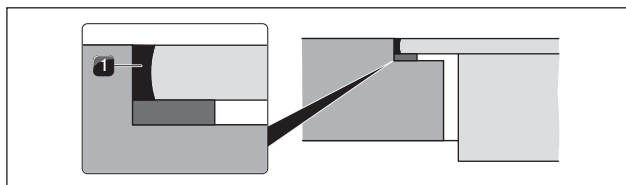

Abb. 5.37 Silicone sealant for surface mounting

[1] Black, heat-resistant silicone sealant

- ▶ Once all of the installation work and initial operation is complete, seal the appliances all the way round (also between the cooktop extractor and cooktop) with black, heat-resistant silicone sealant [1].
- ▶ Make sure that no silicone sealant gets under the cooktop.

5.14 Handover to user

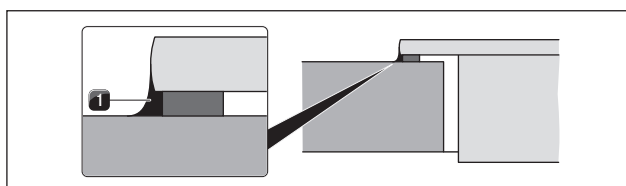
Once installation is complete:

- ▶ Explain the main functions to the user.
- ▶ Explain all safety-related aspects of operation and handling to the user.
- ▶ Affix the supplied nameplate to the back of these instructions.
- ▶ Provide the user with the accessories and all accompanying documents, which are to be kept in a safe place.

6 Configuration menu

Menu overview

Gas configuration menu	
☐E	GPU configuration
☐F	Gas burner characteristic curves
☐h	GPU reset

Tab. 6.1 Gas configuration menu

6.1 How to use the menu

Calling up the menu

i The menu can only be called up when the appliances are switched on but are inactive (= power level 0).

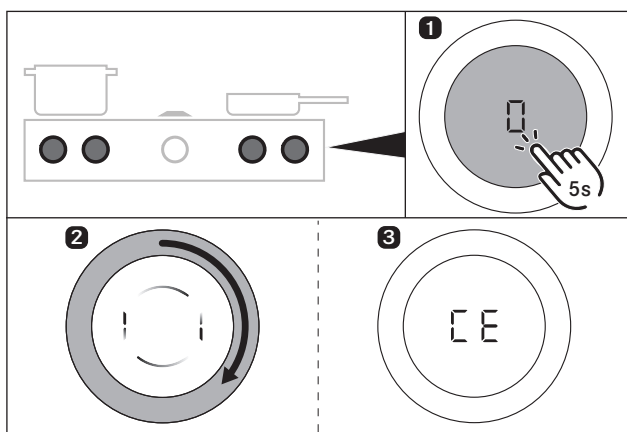

Fig. 6.38 Calling up the menu

- ▶ Extralong press on a control knob on the gas cooktop
- An animation appears (= prompt to turn)
- ▶ Turn the ring on the control knob clockwise
- The menu is called up and the first menu item is displayed.

Explanation of the menu item display (e.g. ☐23):
 Number in middle segment = menu item (100% brightness)
 Number in right-hand segment = current setting (50% brightness)

Selecting and confirming menu items

- ▶ Turn the knob ring to the required menu item (see “Menu overview”).
- ▶ Tap to confirm.

Making, confirming and saving settings

- ▶ Turn the knob ring to the desired setting (for setting options see “Description of menu items”).
- ▶ Tap to confirm the setting.

i The system adopts and saves the settings made when you exit the corresponding menu item or the menu itself.

Closing the menu

- i** When navigating the menu, after the last menu item there is an option **End** to close the menu.
 - ▶ Turn the knob ring to **End**
 - ▶ Tap to confirm the selection.
 - The menu is closed and the standard display appears.
- i** If no settings are changed in a menu or submenu item for 2 minutes, the configuration menu is closed automatically and the display goes out. The settings made are saved automatically.

6.2 Initial operation

6.2.1 Gas configuration menu items

- i** The burner nozzles, gas type, gas pressure and gas characteristic curve may only be changed by a certified engineer or BORA service technician. They also assume responsibility for the proper gas installation and commissioning.
- i** Correct settings are important for the safe, problem-free operation of the gas cooktop.

Menu item ☐E: GPU configuration

i Under menu item ☐E (GPU) the minimum power of each burner and gas type/pressure is regulated.

Setting	Gas type and gas pressure
☐	G20, 20 mbar (Factory setting) G25, 20 mbar
4	G30, 29 mbar G30/G31, 37 mbar
5	G30, 50 mbar G30/G31, 50 mbar
fl	G20, 13 mbar
b	G25, 25 mbar G25.3, 25 mbar
E	G20, 25 mbar

Tab. 6.2 Setting the gas type and gas pressure

Special settings for Australia and New Zealand:

Setting	Gas type and gas pressure
1	G20, 10 mbar
9	G31, 27.5 mbar

Tab. 6.3 Setting the gas type and gas pressure (AU/NZ)

- ▶ Select the correct setting.



Menu item $\square F$: gas burner characteristic curves

The characteristic curves regulate the minimum gas burner power values. The minimum power levels are adjusted using the characteristic curves. Depending on the installation situation and the influence of the cooktop extractor, if necessary, the characteristic curve can be changed.

Characteristic curve A:

Characteristic curve A enables the fine tuning of the power values, which can only be adjusted in the best-case scenario and only in the case of natural gas (G20, G25, G25.3).

The best-case scenario is when:

- no cooktop extractor is in operation; or
- the cooktop, when using the cooktop extractor in exhaust air mode, is used with sufficient ventilation; or
- the cooktop, when using the cooktop extractor in recirculation mode is used with a sufficient return flow aperture and the cooktop extractor does not have a negative influence on the gas flame.

Characteristic curve B:

Factory default characteristic curve with balanced adjustment of the individual power levels.

Characteristic curve C:

Characteristic curve C increases the lower power levels and should only be used in the event of a negative influence from the cooktop extractor.

Setting	Gas burner characteristic curves
\square	Characteristic curve A
	Characteristic curve B (Factory setting)
\square	Characteristic curve C

Tab. 6.4 Characteristic curves for the gas burner

► Select the appropriate characteristic curve.

- i** If the gas flame goes out, is excessively affected by the extractor and/or the flame is not as it should be (e.g. soot production, flame blowback, etc.), the characteristic curve must be increased, as well as the ventilation in exhaust air mode, if necessary, or the return flow aperture in recirculation mode.

Menu item $\square h$: GPU reset

- i** Menu item $\square h$ (GPU reset) provides a reset function. This reset function can be used in the case of faults and errors and during initial operation if the gas cooktop does not react (does not ignite).
- i** The set values for the gas type, pressure and characteristic curve remain unchanged and are not affected by the reset.

Setting	GPU reset
\square	Resetting a locked GPU

Tab. 6.5 Resetting a locked GPU

► Perform a reset if necessary.

7 Functions and operation

- ▶ Observe all safety and warning information during operation (see the “Safety” chapter).

7.1 Knob operation

Operating the knob ring

The ring on the control knob can be turned both clockwise and anticlockwise. It can be turned as far as you wish; there is no defined 0 position.

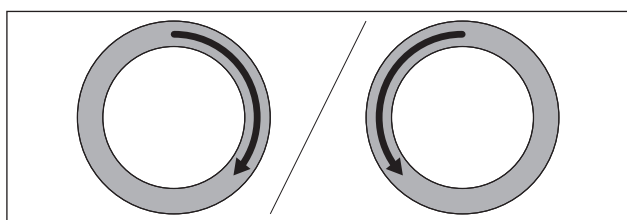

Fig. 7.1 Operating the knob ring

Turn it clockwise (to the right) to:

- switch on
- increase power level/value
- navigate the menu

Turn it anticlockwise (to the left) to:

- switch off
- decrease power level/value
- navigate the menu

Operating the touch surface

The touch surface of the control knob reacts to different touch commands:

Command	Contact	Time
Tap	brief touch	< 1 s
Double tap	2 brief taps one after the other	
Long press	keep finger in place longer	2 - 4 s
Extra-long press	keep finger in place longer	5 - 8 s

Tab. 7.1 Operating the touch surface

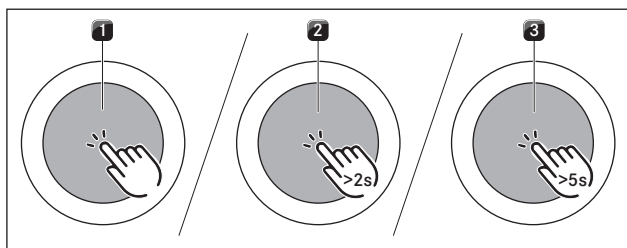

Fig. 7.2 Diagram of the touch commands

- [1] Tap command diagram
 [2] Long press diagram
 [3] Extra-long press diagram

Use tap commands to:

- call up the function menu
- confirm menu items/times/functions

Use double-tap commands to:

- activate the pause function

Use long-press commands to:

- Deactivating the childproofing feature

Use extra-long-press commands to:

- reset the filter service life
- access the configuration menu

7.2 Switching the system on and off

Switching on

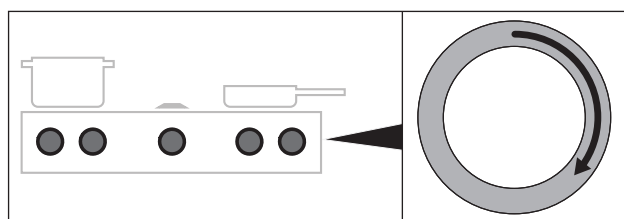

Fig. 7.3 Switching on the system

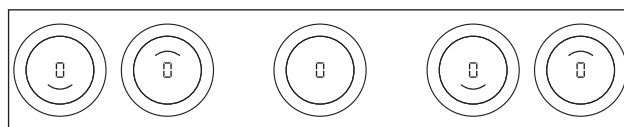

Fig. 7.4 Standard display after switching on

- ▶ Turn a knob ring of your choice clockwise
- The system is activated.
- is displayed on all control knobs.

i If is displayed on all control knobs when the appliance is switched on, the childproofing feature is active. It will only be possible to operate the appliance when this has been deactivated (see “Deactivating the childproofing feature for a cooking session” or “Permanently deactivating the childproofing feature”).

Switching off

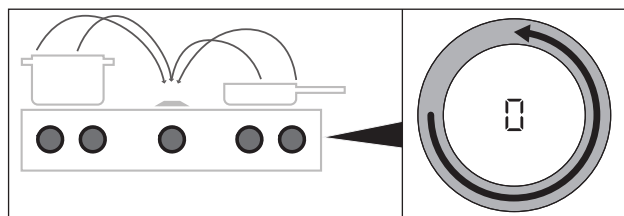

Fig. 7.5 Switching the appliances off

- ▶ Turn the knob ring anticlockwise to power level 0.
- Any active additional functions will be deactivated and the appliance will be switched off.

i If all connected appliances are switched off (= power level 0), the whole system is automatically switched off after 10 seconds.

The cooktop was switched on

- H is shown in the control knob display for previously active and still hot cooking zones (residual heat indicator).
- If there is no longer any residual heat, the display will switch off after 10 seconds.

7.3 Operating the cooktops

i The full range of functions is only available for BORA Professional 3.0 system cooktops in combination with the corresponding cooktop extractors PKA3/PKA3AB and PKAS3/PKAS3AB.

i Clean the cooking zones before using the cooktop for the first time (see the Cleaning chapter).

7.3.1 General operating instructions for cooktops

Cooktops are operated with 2 control knobs.

There are 9 power levels, an optional power setting and various functions available for each cooking zone.

Each cooking zone has its own control knob. The front cooking zone is controlled using the left-hand knob and the rear cooking zone with the right-hand knob.

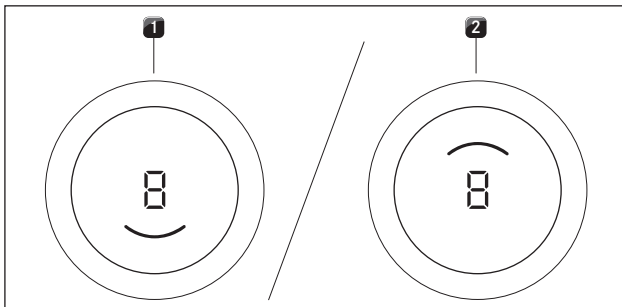

Fig. 7.6 Cooking zone indicator

- [1] active front cooking zone
[2] active rear cooking zone

7.3.2 Special operating instructions for gas cooktop PKG3

i When operating the cooktop for the first time or after a prolonged period without use or when the liquid gas bottles have been changed, it is possible that the burner may not ignite. This may be due to air in the gas pipe or the electronic gas regulator may need recalibrating. Follow the initial operation instructions (see the "Initial operation" chapter).

i Due to the use of enamelled cast iron parts, slight colour variations and irregularities are common. Furthermore, flash rust may appear at the support points, which can be easily removed with a damp cloth. These spots are normal and are not considered an impairment.

i As a result of use, some of the components of the gas cooktop can become discoloured. This discolouration is normal and does not have a negative effect on the gas flame or the functioning of the cooktop.

i When using the gas burner, you may hear gas escaping from it. The burner flame turns orange as a result of impurities on the burner and in the ambient air (dust). These properties are normal and can occur independently of one another.

i In the event of smoke or fire while operating the gas cooktop, turn off the gas supply and switch off the appliance at the wall socket.

i If you smell gas or have problems with the gas installation, switch off the gas supply. Open the window and ensure good ventilation.

- ▶ The use of a gas cooker generates heat, moisture and combustion products in the room in which it is installed. Good ventilation in this room is particularly important when the appliance is in use: natural ventilation openings must be kept open or a mechanical ventilation device should be used. Intensive use of the appliance for a long time may result in a need for additional ventilation, e.g. opening a window, or more effective ventilation, e.g. operation of the mechanical ventilation device at a higher power level.

Correct use of the gas hob

i Do not use the gas cooktop without cookware for extended periods of time (> 5 min) with the cooktop extractor switched on. This results in very high temperatures and may damage the gas cooktop and air-channelling components of the cooktop extractor.

i The tips of the flames should remain under the base of the pot. Protruding flame tips emit heat into the air unnecessarily and can damage pan handles and air-channelling components (cooktop extractor) and increase the risk of burns. Furthermore, the outer part of the gas flame is much hotter than the core.

i Protect your hands when the appliance is hot by using oven gloves or pot holders. Only use dry gloves or pot holders. Wet or damp fabrics conduct heat more easily and can cause steam burns. Ensure that these fabrics do not get too close to the flames. Do not use oversized pot holders, tea towels or similar.

i Grease splashes and other flammable (food) residues on the cooktop can catch fire. Remove them as soon as possible.

- ▶ Do not put cookware with an uneven base on the pan support.
- ▶ Never heat empty cookware.
- ▶ Always place the cookware on the pan support provided. Cookware must not be placed directly on the burner.
- ▶ Do not use roasters, pans or stone grills that are so large that they cover several burners. The resulting heat accumulation can damage the cooktop.

- ▶ Ensure that the burner parts and pan supports are positioned correctly.
- ▶ Do not switch the gas cooktop on until all burner parts are correctly assembled.
- ▶ Ensure that the burner flame does not protrude from under the base of the cookware and rise up the outside of the pot.
- ▶ Do not keep any highly flammable objects near the cooktop.

For maximum performance with minimum gas consumption, we recommend that you:

- ▶ use cookware with a base that covers the flame entirely so that this does not burn beyond the base;
- ▶ use suitable pans on each gas burner;
- ▶ position the cookware centrally on the gas hob;
- ▶ set the gas burner to the lowest power level (small flame) once the pan contents are simmering;
- ▶ adjust the power level of the cooktop extractor to the power level of the gas cooktop.

Using the gas cooktop together with the cooktop extractor

If the gas cooktop is used together with a cooktop extractor, the airflow of the extractor can affect the gas flame.

- ▶ Avoid using a high power level on the cooktop extractor when the gas cooktop is set to a low power level.
- ▶ If necessary, reduce the power level on the cooktop extractor when you turn on the gas cooktop.
- ▶ Do not use the gas cooktop without cookware. The gas flame is protected from the airflow of the cooktop extractor by the geometry of the pan supports and the cookware.

- i** Flames can set fire to or damage the grease filter in the cooktop extractor and the air-channelling components. Never flambé food when using a cooktop extractor.

7.3.3 Setting cooking zone power levels

The power levels are controlled by turning the knob ring to the desired power level (electronic power adjustment).

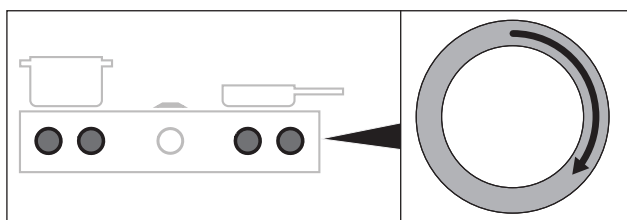

Fig. 7.7 Setting cooking zone power levels

- The selected power level is shown in the power display on the control knob that has been touched.
- Upon touching a control knob, the selected power level is shown in the display.

Increasing the power level

- ▶ Turn the knob ring clockwise

Reducing the power level

- ▶ Turn the knob ring anticlockwise

7.3.4 Cooktop power setting

When the power setting is activated, maximum cooking zone power is available for a predefined time.

- i** Never heat up oil, fat and the like on this power setting. The bottom of the pan can overheat due to the high power output.

Activating the power setting for a cooking zone

- ▶ Turn the knob ring clockwise to power setting P.

- i** After 10 minutes, the power setting is automatically switched back to power level 9.

- i** After 20 minutes, the power setting is automatically switched back to power level 9.

Deactivating the power setting early

- Setting another power level for the cooking zone with the power setting active

7.4 Function menu

- i** Every appliance offers different additional functions. These can be selected and activated via a function menu. Only the functions available for each type of appliance are shown in the corresponding function menu.

Function menu on gas cooktop PKG3

A total of 3 additional functions are available on gas cooktops:

Menu item	Description
⏸	Heat retention function (3 levels)
⏰	Timer function (automatic cut-off)
⏹	Automatic heat up function

Tab. 7.2 Function menu on gas cooktop PKG3

Calling up the function menu

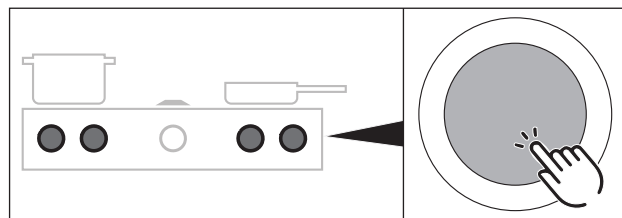

Fig. 7.8 Accessing a cooktop function menu

- ▶ Touch the cooktop control knob
- The function menu is opened.
- The first menu item is shown in the control knob display.

7.4.1 Variable heat retention function

The 3 heat retention levels enable cooked foods to be kept warm at a constant temperature.

- The maximum duration of the heat retention function is limited to 8 hours.

Heat retention level	Symbol	Temperature	Use
1	- U	42 °C	Melting chocolate
2	= U	74 °C	Keeping food warm
3	≡ U	94 °C	Simmering

Tab. 7.3 Heat retention levels

i In practice the temperatures of the heat retention levels may vary slightly as they are influenced by the cookware, the amount of food and the different heating technologies. The temperatures can also vary due to the influence of the cooktop extractor.

Activating the heat retention function

- ▶ Open the cooktop function menu.
- ▶ Enter the following settings:

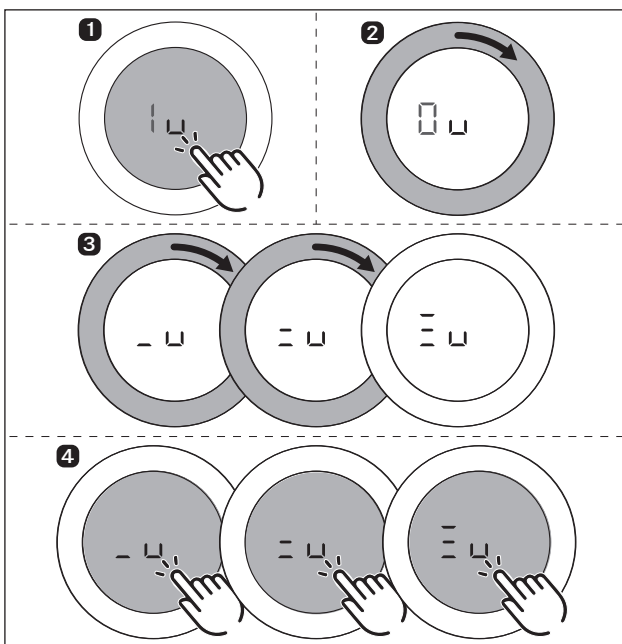

Fig. 7.9 Activating the heat retention function

Increasing or reducing the active heat retention level

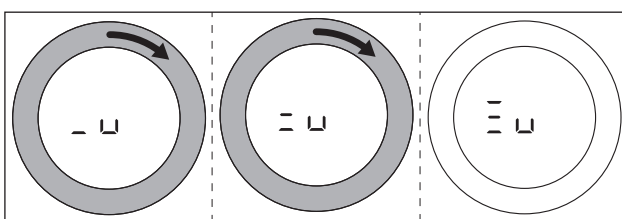

Fig. 7.10 Increasing the active heat retention level

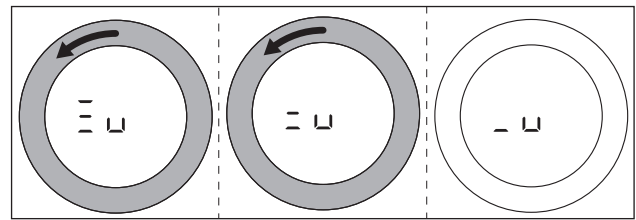

Fig. 7.11 Reducing the active heat retention level

Deactivating the heat retention function

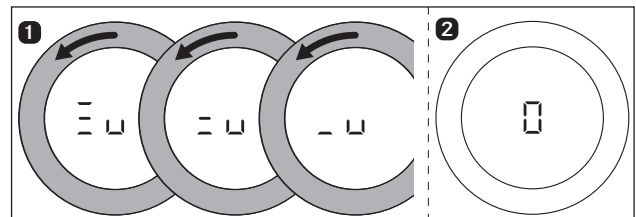

Fig. 7.12 Deactivating the heat retention function

- The cooking zone is deactivated and the control knob display shows 0.
- The residual heat indicator H appears in the control knob display if necessary.

7.4.2 Timer function/automatic cut-off

When a cooking zone is in operation, the automatic cut-off on the timer function automatically switches it off once a preset time has lapsed.

- i** You can set a time range of between 1 and 120 minutes for the timer functions.

Activating cooking zone timers

- ▶ Open the cooktop function menu.
- ▶ Do the following:

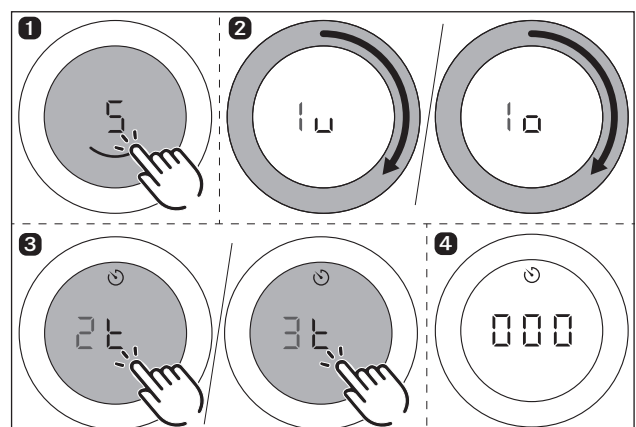

Fig. 7.13 Activating cooking zone timers

- The timer is activated for the chosen cooking zone.
- The control knob display shows the time to be set beginning at 000 and the timer symbol.
- If no time is set within 4 seconds, the timer is deactivated. The control knob display goes back to the current cooking session.

Setting the time and starting the timer

- i** Turning clockwise increases the time (starting at 0 minutes). Turning anticlockwise reduces the time.

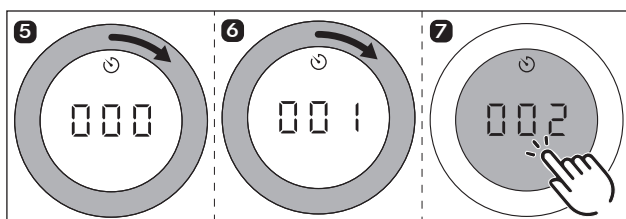

Fig. 7.14 Turning the knob ring clockwise

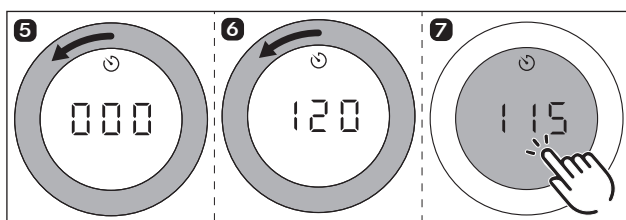



Fig. 7.15 Turning the knob ring anticlockwise

- In the range from 0 to 20 minutes, the time reduces/ increases in both directions by one minute at a time, while the increments are 5 minutes for the rest of the range.
- After confirming with a touch command, an acoustic signal is heard, the cooking zone timer is activated and the set time starts to count down.
- The control knob display changes to the current cooking session and the timer symbol  is displayed.
- The set power level and the remaining time are shown alternately in the control knob display for 3 seconds.
- Once the remaining time is less than 2 minutes, only the remaining time is displayed.
- Once the remaining time is less than 5 seconds, the remaining time flashes.

Changing active timers

- ▶ Repeat the steps for cooking zones with an active timer (see “Activating cooking zone timers”).
- ▶ Change the set time and restart the timer.

Switching the timer off early



If the cooking session is to be continued:

- ▶ open the cooktop function menu;
- ▶ select the menu item “timer function (automatic cut-off)”;
- ▶ decrease the set time to  and confirm the entry.
- The timer is deactivated early and an acoustic signal is heard.
- Active cooking sessions are resumed unchanged.

If the cooking session is to be ended:

- ▶ turn the knob ring to power level 
- An acoustic signal sounds and the cooking zone is switched off.

Time lapsed

- The cooking zone switches off automatically.
- An acoustic signal is heard.
-  and the timer symbol  can be seen flashing in the control knob display.

- After 5 seconds the acoustic signal and the flashing display are automatically deactivated.
- i** The flashing display and acoustic signal can be stopped early with a touch command on the control knob.
- If necessary, the residual heat indicator H is then displayed.

7.4.3 Automatic heat up function

When the automatic heat up function is activated, the cooking zone works at full power for a certain time and is then automatically reset to the previously set level. The system automatically determines the heating time depending on the power level set.

PKG3	Power level (continuous cooking level)	Cooking times in min:sec
1		00:40
2		01:00
3		02:00
4		03:00
5		04:20
6		07:00
7		02:00
8		03:00

Tab. 7.4 Overview of heating times

- i** If the cooking zone power level is increased while the automatic heat up function is active, the automatic heat up function remains active. The heating time is adjusted accordingly.
- i** If the cooking zone power level is decreased while the automatic heat up function is active, the automatic heat up function is deactivated.

Requirement for the automatic heat up function:

- cooking session with a power level between 1 and 8.

Activating the automatic heat up function

- ▶ Open the cooktop function menu.
- ▶ Do the following:

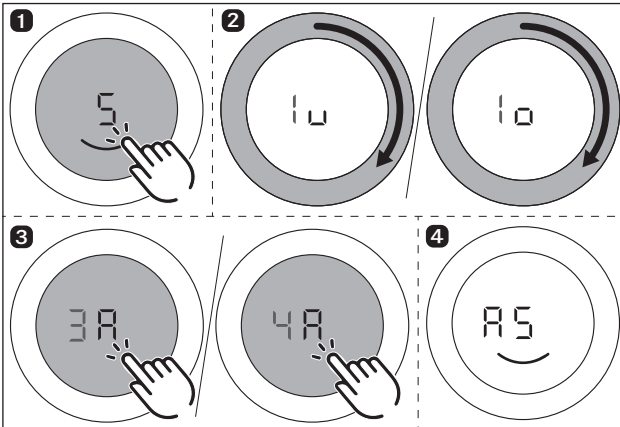

Fig. 7.16 Activating the automatic heat up function

- An acoustic signal is heard, the automatic heat up function is activated and the corresponding timer counts down.
- The heat-up symbol A and the set power level are shown in the control knob display (e.g. A5).

Deactivating the automatic heat up function early

The activated automatic heat up function will end prematurely if you

- ▶ reduce the power level (continuous cooking level);
- ▶ set the power level 9 ;
- ▶ activate the power setting P ;
- ▶ activate the heat retention level U ;
- ▶ switch off the cooktop.

Time lapsed

- When the heat up time has lapsed, the previously set continuous cooking level will be activated.
- An acoustic signal is heard.
- The heat up symbol will no longer be displayed

8 Cleaning and maintenance

- ▶ Observe all safety and warning information (see the Safety chapter).
- ▶ Follow the enclosed manufacturer's information.
- ▶ When conducting scheduled cleaning and maintenance, ensure that the cooktop and cooktop extractor are fully switched off and cooled so as to prevent injury (see the Operation chapter).
- Regular cleaning and maintenance ensures long service life of the product and optimal function.
- ▶ Adhere to the following cleaning and maintenance cycles:

Component	Cleaning cycle
Control knob:	
Knob ring/knob housing	Immediately after every soiling
Gas cooktop:	
Cooktop	Clean well immediately after soiling, using conventional detergents
Pan support	
Gas burner	

Tab. 8.1 Cleaning cycles

8.1 Cleaning agents

- i** Due to the use of aggressive cleaning agents and abrasion caused by the pot bases the surface will become damaged and dark stains will occur.
- ▶ Never use steam cleaners, abrasive sponges, scouring pads or chemically aggressive cleaning agents (e.g. oven cleaner spray).
- ▶ Make sure that the cleaning agent does not contain any sand, soda, acids, lyes or chloride.

Cleaning products for glass ceramic cooktops

To clean the cooktop, you need a special glass ceramic scraper and suitable cleaning agents.

8.2 Cleaning the cooktops

8.2.1 Cleaning glass ceramic cooktops

- ▶ Make sure that the cooktop is switched off (see the Operation chapter).
- ▶ Make sure the gas supply is interrupted and switched off.
- ▶ Wait until all cooking zones are cold.
- ▶ Remove all coarse dirt and food residues from the cooktop using a glass ceramic scraper.
- ▶ Apply the cleaning agent to the cold cooktop.
- ▶ Spread the cleaning agent using kitchen roll or a clean cloth.
- ▶ Wipe the cooktop clean with a damp cloth.
- ▶ Dry the cooktop with a clean cloth.

If the cooktop is hot:

- ▶ remove stubborn residues of plastic, aluminium foil, sugar or sweet dishes from the hot cooking zone immediately using a glass ceramic scraper to prevent burning.

Heavy soiling

- ▶ Remove heavy soiling and marks (limescale marks, mother-of-pearl-like shiny marks) using cleaning products while the cooktop is still warm.
- ▶ Wipe off any food that boils over with a damp cloth.
- ▶ Remove any remaining dirt with the glass ceramic scraper.
- ▶ Always remove any seeds, crumbs or similar that fall onto the cooktop during cooking immediately to prevent the surface getting scratched.

Any changes in colour or glossy spots do not mean that the cooktop is damaged. They do not affect the functionality of the cooktop or the stability of the glass ceramic panel.

Changes in the colour of the cooktop are the result of residues which have not been removed and have burnt on.

Glossy spots are the result of wear by the pan base, especially if aluminium-based cookware or unsuitable cleaning agents are used. These are difficult to remove.

- i** Due to the use of enamelled cast iron parts, slight colour variations and irregularities are common. Furthermore, flash rust may appear at the support points, which can be easily removed with a damp cloth. These spots are normal and do not constitute an impairment

8.2.2 Cleaning the pan supports

- i** The surface of the pan support will become duller with the passing of time. This is quite normal and does not mean that the material is damaged.
- i** The pan supports must be washed by hand every time they become dirty.

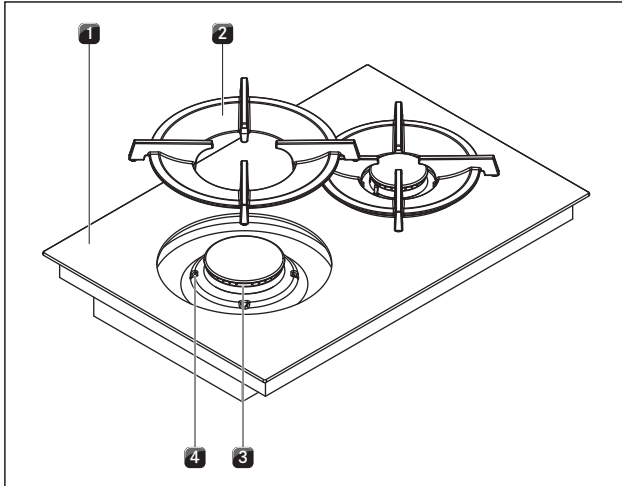

Fig. 8.1 Gas burner structure

- [1] Gas cooktop
- [2] Pan support
- [3] Gas burner
- [4] Positioning aid

- ▶ Remove the pan support [2].
- Pan supports can only be cleaned by hand.

Manual cleaning

- ▶ Use a cleaner and degreaser in one.
- ▶ Rinse the pan supports with hot water.
- ▶ Clean the pan supports with a soft brush.
- ▶ Rinse the pan supports well after cleaning.
- ▶ Dry the pan supports carefully with a clean cloth.

- i** In the case of particularly stubborn or burned-on dirt, the pan support can be briefly soaked in warm water with washing-up liquid. Any limescale marks can be more easily removed with diluted vinegar.

8.2.3 Cleaning the gas burner parts

- i** The surface of the burner cap will become duller with the passing of time. This is quite normal and does not mean that the material is damaged.

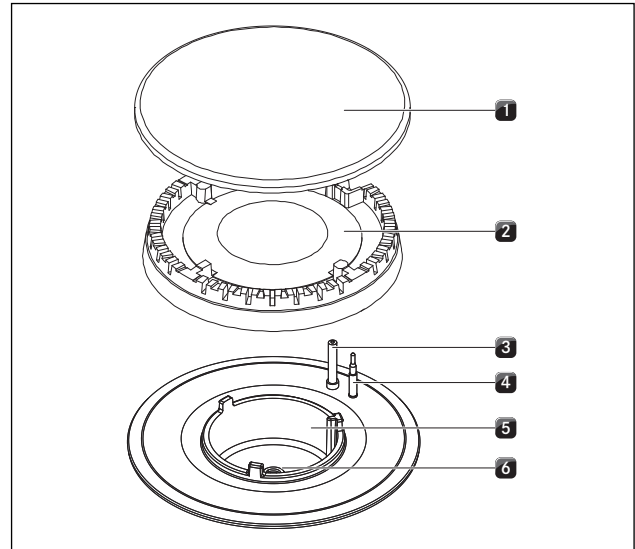

Fig. 8.2 Gas burner structure

- [1] Burner cap
- [2] Burner head
- [3] Electric igniter
- [4] Safety thermocouple
- [5] Burner housing
- [6] Gas burner nozzle

- Do not start cleaning until the gas burner has returned to normal temperature after use.
- The burner parts are not suitable for cleaning in the dishwasher. Clean the burner parts by hand only.
- Only clean with normal hot water to rinse and a conventional washing-up liquid, using a soft sponge or a normal dishcloth.
- Never scratch or scrape cooking residues off.
- ▶ Remove the pan support.
- ▶ Remove the burner cap [1] from the burner head [2].
- ▶ Remove the burner head [2] from the gas outlet
- ▶ Clean the parts of the burner.
- ▶ Clean all of the flame outlet openings with a non-metallic brush.
- ▶ Wipe the fixed parts of the burner with a damp cloth.
- ▶ Wipe the igniter electrode [3] and the thermocouple [4] carefully with a well-wrung-out cloth.
- The igniter electrode must not get wet, otherwise the ignition spark will not light.
- ▶ Finally, dry the pan supports carefully with a clean cloth.
- Before reassembling the flame openings, burner heads and burner caps must be completely dry.
- ▶ Put the burner parts back together again.
- ▶ Position the burner head [2] correctly on the gas outlet.
- ▶ Ensure that the safety thermocouple [4] and the electric igniter [3] are positioned in the correct opening.
- ▶ Position the burner cap [1] so that it fits perfectly, sitting straight on the burner head [2].
- If burner parts are not positioned correctly, the electric igniter will not work.
- ▶ Place the pan support straight on the gas burner so it fits perfectly.
- ▶ Put the gas burner into operation (see the Operation chapter).

8.3 Looking after your cooktops

- ▶ Never use a cooktop as a work or storage surface.
- ▶ Do not push or pull cookware over the cooktop.
- ▶ Always lift pots and pans.
- ▶ Keep the cooktop clean.
- ▶ Remove any dirt immediately.
- ▶ Only use suitable cookware on the appliance (see the Appliance description chapter).

8.4 Cleaning the control knobs

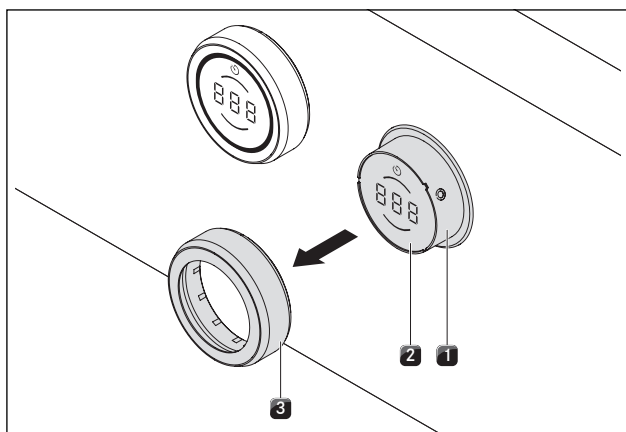

Fig. 8.3 Pull out the knob ring

- [1] Knob housing
- [2] Touch surface
- [3] Knob ring

Cleaning the knob ring

The knob ring can only be cleaned by hand.

- ▶ Remove the knob ring from the knob housing.
- ▶ Use a cleaner and degreaser in one.
- ▶ Rinse the knob ring with hot water.
- ▶ Clean the knob ring with a soft brush.
- ▶ Rinse the knob ring well after cleaning.
- ▶ Dry the knob ring carefully.
- ▶ Place the dry knob ring back on the knob housing.

Cleaning the touch surface and the knob housing

- ▶ Remove the knob ring.
- ▶ Clean the touch surface and the knob housing with a soft, damp cloth.
- ▶ Dry the touch surface and the knob housing carefully.
- ▶ Place the knob ring on the knob housing.

9 Troubleshooting

► Observe all safety and warning information (see the “Safety” chapter).

Operating situation	Cause	Remedy
When operating for the first time, after a prolonged period without use or after changing the gas bottle: burner doesn't ignite.	There is air in the gas pipe.	Repeat the ignition process several times if necessary. This can be done using the touch-operated area of the control knob if the power level is flashing or by turning the control knob to power level 0, then setting the power level.
Gas cooktop does not react (servomotors do not calibrate and no ignition).	There is a communication error between the operating unit and the cooktop (e.g. in the event of a power cut).	Perform a reset (see “Gas configuration menu”).
The gas burner cannot be ignited electrically.	The gas burners are damp.	Dry the gas burner parts (see the “Cleaning” chapter).
	The gas burner heads and/or the gas burner cover are not correctly positioned.	Position the gas burner parts correctly (see the “Cleaning” chapter).
	The electric igniter and/or thermocouple are dirty.	Remove the dirt (see the “Cleaning” chapter).
	Dirt in the gas burner head.	Clean the gas burner parts (see the “Cleaning” chapter).
	Ignition failed. Power display flashes.	Repeat the ignition process by setting a power level. If the power level is flashing, this can be done using the touch-operated area of the control knob.
During normal operation:		
you notice the smell of gas.	A leakage point in the gas supply line.	Switch off the gas supply and immediately extinguish all open flames. Contact a gas engineer. Ensure that all connections are tight (see the “Gas installation” chapter).
No gas is coming out of the gas burners.	The gas supply is closed.	Open the gas supply (see the “Operation” chapter).
	The gas bottle is empty.	Exchange the empty gas bottle for a full gas bottle of the correct gas type.
The gas flame goes out after ignition. The gas flame goes out during operation. The gas flame is uneven.	The gas burner parts (burner heads and/or the gas burner cover) are not correctly positioned.	Position the gas burner parts correctly (see the “Cleaning” chapter).
	Dirt in the gas outlet openings on the gas burner head.	Clean the gas burner parts (see the “Cleaning” chapter).
The cooktop cannot be switched on.	Knob ring missing.	Slot the knob ring onto the control knob.
	The fuse or automatic circuit breaker of the electrical wiring system in the apartment and/or house is defective.	Replace the fuse. Switch the automatic circuit breaker back on.
	The fuse or the automatic circuit breaker trips several times.	Contact the BORA Service Team.
	The power supply is disconnected.	Have a specialist electrician inspect the power supply.
Odours and vapours are formed when operating the new cooktop.	This is normal with brand new appliances.	Wait a few operating hours.
		If odours continue to form, contact the BORA Service Team.
A cooking zone or the entire cooktop switches off automatically.	A cooking zone has been in operation too long.	Put the cooking zone back into operation (see the “Operation” chapter).
	The overheating protection has tripped.	(see the “Appliance description” chapter).
The power setting is automatically shut off prematurely.	The overheating protection has tripped.	(see the “Appliance description” chapter).
Control knob display L.	The childproofing feature is activated.	Switch off the childproofing feature (see the “Operation” chapter).



Operating situation	Cause	Remedy
Control knob display r' .	Continuous operation (8 s) of the control knob or control knob dirty.	Take your finger off the control knob or clean the knob.
Control knob display $E001, E002$.	Error when the software is running.	Perform a reset (configuration Ch) (see the "Installation" chapter). Disconnect the device from the mains for at least 1 min. and restart it. Contact the BORA Service Team.
Control knob display $E021, E051$.	Temperature too high.	Allow the cooktop to cool.
Control knob display $E082, E083$.	Check the connection to the temperature sensor.	Replace temperature sensor. Call the BORA Service Team.
Control knob display $E019$.	Error in the touch surface values.	Perform touch command. Call the BORA Service Team.
Error code $E066$.	Gas supply interrupted and/or no flame detected. The gas bottle is empty.	Repeat the ignition process several times if necessary. This can be done with a touch command on the control knob when the power level is flashing or by turning the control knob to power level 0 and then setting the power level. Confirm error E_066 and try to ignite it again. (The gas pipe needs a certain amount of time to fill after installation). Check the gas or mains connection. Contact the BORA Service Team.

Tab. 9.1 Resolving a fault

- ▶ After troubleshooting try again and check that the problem has been solved.
- ▶ With all faults, try restarting the system.
- ▶ As a last resort, briefly disconnect the power supply.

i During or after an interruption to the power supply, the cooktops may still be hot. In the case of cooktops PKCH3, PKCB3 and PKG3, after an interruption to the power supply the residual heat is not displayed, even if they were previously in operation and the cooking zones are still hot.

- ▶ Should faults arise frequently, contact the BORA Service Team (see the "Warranty, service, spare parts and accessories" chapter) and specify the error number displayed and the appliance type (see the "Identification plates" chapter).

10 Decommissioning, disassembly and disposal

- ▶ Observe all safety and warning information (see the Safety section).
- ▶ Follow the enclosed manufacturer's information.

10.1 Decommissioning

Decommissioning is understood as final shutdown and disassembly. Following decommissioning, the device can either be installed into other units, sold on privately or disposed of.

i Electricity and gas connections may only be disconnected by qualified specialists.

- ▶ To decommission, switch the device off (see Operation section)
- ▶ Disconnect the device from the power supply.
- ▶ Disconnect the device from the gas supply.

10.2 Disassembly

For removal, the device must be accessible for disassembly and disconnected from the power supply.

For gas devices, make sure the gas connection is disconnected.

- ▶ Undo the appliance fixture.
- ▶ Remove the silicone joints.
- ▶ Remove the device from the worktop by lifting it upwards.
- ▶ Remove any other accessories.
- ▶ Dispose of the old device and any contaminated accessories as described under "Environmentally-friendly disposal".

10.3 Environmentally-friendly disposal

Disposal of transport packaging

i The packaging protects the device from damage in transport. The packaging materials have been selected from environmental and disposal perspectives and are therefore recyclable.

Returning the packaging to the materials cycle saves resources and reduces waste volumes. Your specialist supplier will take the packaging back.

- ▶ Give the packaging to your specialist supplier or
- ▶ Dispose of the packaging properly in line with local regulations.

Disposal of old appliance



Electrical devices marked with this label may not be disposed of in domestic waste at the end of their service life. They must be disposed of at a collection point for the recycling of old electrical or electronic devices. You can find information from your city or district council.

Many electrical and electronic devices still contain valuable materials. But they also contain damaging materials which were necessary for them to function properly and safely. These can damage human health or the environment if disposed of improperly or incorrectly handled.

- ▶ Never put your old appliance in domestic waste.
- ▶ Take the old appliance to a regional collection point for return and recycling electrical and electronic components and other materials.

11 Warranty, technical service, spare parts, accessories

- Observe all safety and warning information (see the Safety chapter).

11.1 BORA manufacturer's warranty

BORA provides its end customers with a 2-year manufacturer's warranty for its products. The end customer is entitled to this warranty in addition to the statutory claims for defects against the sellers of our products.

The manufacturer's warranty applies to all BORA products sold by authorised BORA dealers or BORA-trained salespeople within the European Union, with the exception of products labelled by BORA as Universal products or accessories.

The manufacturer's warranty starts as soon as the BORA product is handed over to the end customer by an authorised BORA dealer and is valid for 2 years. By registering on www.bora.com/registration the end customer has the possibility of extending the manufacturer's warranty.

The manufacturer's warranty requires expert (in accordance with the valid BORA ventilation handbook and operating instructions at the time of installation) installation of the BORA products by an authorised BORA dealer. During use, the end customer is to adhere to the specifications and instructions in the operating manual.

In order to file a warranty claim, the end customer is to notify their dealer or BORA of the fault and must present the receipt. Alternatively, the end customer can provide proof of purchase by registering on www.bora.com.

BORA guarantees that all BORA products are free from material and product defects. The defect must exist prior to delivery of the product to the end customer. In the event that a warranty claim is filed, the warranty shall not commence anew.

BORA will correct defects in BORA products at its own discretion by repairing or replacing the product. All costs for the correction of defects under the manufacturer's warranty shall be assumed by BORA.

Expressly not covered by the BORA manufacturer's warranty are:

- BORA products that were not sold by authorised BORA dealers or from BORA-trained salespeople.
- Damage caused by non-adherence to the operating instructions (including product care and cleaning) This represents improper use.
- Damage caused by normal use, e.g. traces of usage on the cooktop
- Damage caused by external influences (such as transport damage, ingress of condensation, damage caused by the elements such as a lightning strike)
- Damage caused by repairs or attempts to repair not made by BORA or persons authorised by BORA
- Damage to the glass ceramic
- Voltage fluctuations
- Secondary damage or claims for damages beyond the defect
- Damage to plastic parts

Legal claims, such as particularly statutory claims for defects or product liability are not limited by the warranty.

If a defect is not covered by the manufacturer's warranty, the end customer can employ the services of the BORA technical service, however, they must cover the costs themselves.

The laws of the Federal Republic of Germany apply to these warranty conditions.

You can contact us by:

- Telephone: +49 800 7890 0987 Monday to Thursday from 08:00-18:00 and Friday from 08:00-17:00
- Email: info@bora.com

11.2 Service

BORA Service:

see reverse side of operating and assembly instructions



- In the case of faults you cannot fix yourself, contact your BORA specialist supplier or the BORA Service Team. The BORA Service Team will require the type designation and serial number of your device (FD number).

Both pieces of information can be found on the nameplate on the back of the instructions and on the appliance base.

11.3 Spare parts

- Only use original spare parts for repairs.
- Repairs may only be carried out by the BORA Service Team.



Spare parts can be obtained from your BORA dealer, the BORA online service website at www.bora.com/service or by calling the service number provided.

11.4 Accessories

- BORA Pro knob ring PKR3
- BORA Pro knob ring All Black PKR3AB

Special accessory for glass ceramic cooktops:

- BORA Glass ceramic scraper UGS

Special accessory for PKG3:

- BORA gas nozzle set natural gas G25/25 mbar PKGDS2525
- BORA gas nozzle set natural gas G20/13 mbar PKGDS2013
- BORA gas nozzle set natural gas G20/20 mbar PKGDS2020
- BORA gas nozzle set natural gas G25/20 mbar PKGDS2520
- BORA gas nozzle set natural gas G20/25 mbar PKGDS2025
- BORA gas nozzle set liquid gas G30/G31 50 mbar PKGDS3050
- BORA gas nozzle set liquid gas G30/G31 28-30 mbar PKGDS3028
- BORA burner set PKGBS
- BORA pan support small PKGTK
- BORA pan support big PKGTG

12 Notes



Nameplate:
(please affix)

Operating and installation instructions:

Original

Translation

Manufacturer: BORA Vertriebs GmbH & Co KG

The distribution and duplication of this document, as well as the use and disclosure of its contents are prohibited unless expressly authorised.

These operating and installation instructions have been drawn up with the greatest of care. But it cannot be ruled out that subsequent technical modifications have not yet been incorporated or the relevant content has not yet been adapted. Please accept our apologies in this eventuality. An updated version can be requested from the BORA Service Team. Subject to printing errors and mistakes.

© BORA Vertriebs GmbH & Co KG

All rights reserved.

(D)

BORA Lüftungstechnik GmbH

Rosenheimer Str. 33
83064 Raubling
Germany
T +49 (0) 8035 / 9840-0
F +49 (0) 8035 / 9840-300
info@bora.com
www.bora.com

(A)

BORA Vertriebs GmbH & Co KG

Innstraße 1
6342 Niederndorf
Austria
T +43 (0) 5373 / 62250-0
F +43 (0) 5373 / 62250-90
mail@bora.com
www.bora.com

(INT)

BORA Holding GmbH

Innstraße 1
6342 Niederndorf
Austria
T +43 (0) 5373 / 62250-0
F +43 (0) 5373 / 62250-90
mail@bora.com
www.bora.com

(AU) (NZ)

BORA APAC Pty Ltd

100 Victoria Road
Drummoyne NSW 2047
Australien
T +61 2 9719 2350
F +61 2 8076 3514
info@boraapac.com.au
www.bora-australia.com.au

